

Sunbeam®

True HEPA Air Cleaner with Ionizer

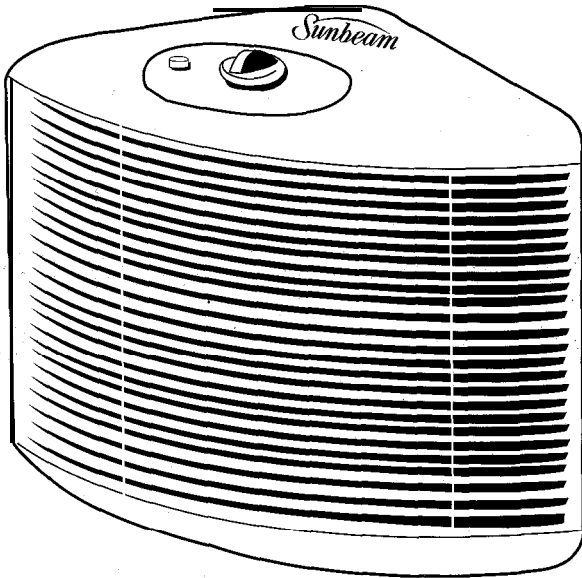

Model 2587/2588

Please read and save these instructions

PLEASE READ AND SAVE THESE IMPORTANT SAFEGUARDS

WHEN USING ELECTRICAL APPLIANCES BASIC SAFETY PRECAUTIONS SHOULD ALWAYS BE FOLLOWED, INCLUDING THE FOLLOWING:

1. Read all instructions before using the appliance.
2. To avoid fire or shock hazard, plug the air purifier directly into a 120V. AC. electrical outlet.

CAUTION: TO PREVENT ELECTRIC SHOCK, MATCH THE WIDE BLADE OF THE POLARIZED PLUG TO THE WIDE SLOT IN THE OUTLET, FULLY INSERT PLUG. IF PLUG DOES NOT FIT, CONTACT A QUALIFIED ELECTRICIAN TO INSTALL PROPER OUTLET. DO NOT CHANGE PLUG IN ANY WAY.

3. Keep the cord out of heavy traffic areas. To avoid fire hazard, never put the cord under rugs, near heat registers, radiators, stoves or heaters.
4. To protect against electrical hazards do not immerse in water or other liquids. Do not use while bathing.
5. Close supervision is necessary when any appliance is used by or near children, or by invalids.
6. Always unplug the air purifier before moving it, opening the grill, changing filters, before cleaning, or whenever the air purifier is not in use.
7. Do not put foreign objects inside the air purifier.
8. Do not operate any appliance with a damaged cord or plug, if fan fails to rotate, or after the appliance malfunctions or has been dropped or damaged in any manner. Return appliance to manufacturer for examination, electrical or mechanical adjustment or repair. (See warranty for information).
9. Use appliance only for intended household use as described in this manual.
10. Do not use outdoors.
11. Never block the air opening or place on a soft surface such as a bed, or sofas where opening may be blocked.
12. Keep cord away from heated surfaces.
13. Do not immerse in water. It will cause permanent damage.

PLEASE SAVE THESE INSTRUCTIONS

FEATURES

- Your Sunbeam Air Cleaner is designed to provide you with the latest technology and features in portable airfiltering equipment.
- Your Sunbeam Air Cleaner includes a true HEPA filter combined with a pre-foam filter and ionizer to provide you with the most efficient air cleaning product on the market.
- Your Sunbeam Air Cleaner is also designed for today's lifestyle. With its unique 3-way positioning, your Sunbeam Air Cleaner is the perfect match for any room or office. Set it on its base, on its side, or mount it to the wall. In any position it is designed to deliver maximum air cleaning efficiencies.
- The three-speed fan allows you to control the speed of the unit as well, as the sound. Set the unit on High to circulate and clean the air when you are not in the room. Use the medium and low speeds to maintain the clean air while you are in the room.
- Your Sunbeam HEPA Air Cleaner is designed to remove up to 99.97% of airborne particles such as pollen, dust, smoke, spores, and bacteria. This air cleaner will clean a 10'x12 room six times an hour on high speed.
- Your Sunbeam HEPA Air Cleaner comes equipped with an independent ionizer. When the ionizer is switched on, it releases negative ions into the exiting filtered air. These negative ions will eventually come in contact with tiny airborne particles and give them a negative charge. These tiny charged negative particles will either collect on positively charged surfaces such as floors or furniture, or will combine with larger positively charged airborne particles and be filtered out of the air through the air cleaner.

OPERATING INSTRUCTIONS

1. Make sure air cleaner is placed on a hard stable surface.
2. Plug into a 120V AC electrical outlet.
3. Select the desired speed by turning the knob to the appropriate setting. At this point, the operational light should come on.
4. Push down the ionizer button to release the negative ions into the air. At this point, the ionizer light should come on., Note: it is possible to release the negative ions without the fan being on. We suggest that you turn the fan on along with the ionizer to avoid any particle build up on surfaces close to the air cleaner.
5. Timer feature-(model 2588 only) Push timer button down. This will automatically activate timer, Unit will run for two hours on medium air cleaning efficiency then automatically shut off.

CLEANING/MAINTENANCE INSTRUCTIONS

1. Always unplug the unit before cleaning.
2. Outside surfaces can be cleaned with a soft cloth.
3. The inlet grill can be removed and soaked in warm soapy water. It is not dishwasher safe. Dry grill thoroughly before replacing on unit.
4. The outlet grill can be cleaned with a soft cloth or soft brush.
5. Do not submerge in water, or allow water to come in contact with the air cleaner.

FILTER REPLACEMENT

1. As always, unplug unit prior to opening grill.
2. Open and remove inlet grill by depressing latches of bottom or right side of grill (depending on orientation) and pulling away from air cleaner until hooks near outlet grill come free.
3. Check the appearance of the prefilter to see if there is a visible amount of dust or lint. If so, simply soak the prefilter in warm soapy water and completely dry before replacing in the unit.
4. Check the HEPA filter cartridge to see which condition it matches on the filter indicator located on the housing of the unit near the outlet grill.

If the filter is brown in color, then it is time to change to a new filter, Remove the HEPA filter and replace it with a new Sunbeam HEPA filter, Model 6613. This filter also comes with a new foam prefilter: Do not attempt to wash the HEPA filter,

5. Under normal conditions the HEPA filter should last 9-12 months. Frequent cleaning of the pre-filter will help extend the life of the HEPA filter.
6. The replacement HEPA filter and pre-filter, Model 6613 can be purchased from your local supplier. In U.S. call 1-800-597-5978 and in Canada call 1-800-66-SUNBEAM for the supplier nearest you.

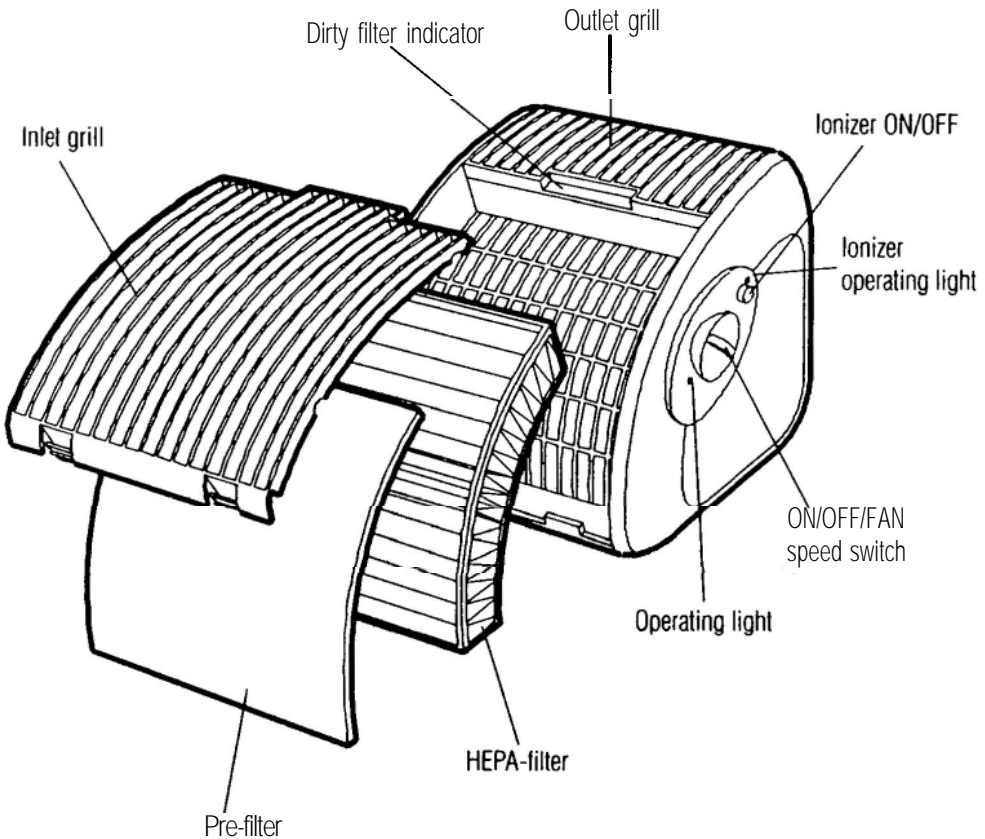

LIMITED WARRANTY

What is Covered and For How Long

Congratulations on your recent purchase of a quality Sunbeam-Oster product. We are confident that our product will perform well and, therefore warrant to you as the original retail purchaser, for a period of 1 year from the date of original purchase, that your new product will be free of mechanical and electrical defects in material and workmanship.

What Sunbeam-Oster Will Do & How to Get Service

If your product is covered during the warranty period, we will repair or replace your new product (at our option) without cost to you, which will be your exclusive remedy under this warranty. Please do not return this product to the place of purchase; doing so may delay the processing of your claim and our repair of your product. Simply send your product postage prepaid, with proof of purchase and a short description of the problem directly to our factory service center at the following address:

In the US.:

SUNBEAM HOUSEHOLD PRODUCTS
Service Station
95 W.L. Industrial Drive
Hattiesburg, MS 39401

In Canada:

SUNBEAM CANADA
Service Station
5975 Falbourne Street
Mississauga, Ontario L5R 3V6

What is Not Covered

Our warranty for your product will not cover normal wear of parts, damage resulting from negligent use or misuse of the product, use on improper voltage or current, use contrary to operating instructions, glass breakage (if applicable), or disassembly, repair, or alteration by any person other than an authorized service station. Any implied warranty of merchantability or fitness for a particular purpose on your product is limited to the duration of this written warranty. We shall not be liable for any incidental or consequential damages for breach of any express or implied warranty on your product.

How Your State's Law May Apply

Some states do not allow limitations on how long an implied warranty lasts or the exclusion or limitation of incidental or consequential damages, so the above limitation may not apply to you. This warranty gives you specific legal rights, and you may also have other rights which vary from state to state.

If you have any questions or comments, please call our toll free number and a customer service representative will be happy to help you. In the US. 1-800-526-2832
In Canada 1-800-66-SUNBEAM

67133

The Sunbeam logo features the word "Sunbeam" in a classic, elegant cursive script. A thin, curved line arches over the letters, starting above the 'S' and ending above the 'm', resembling a sun's rays or a protective shield.

1995 Sunbeam Corporation or its affiliated companies,
all rights reserved. Sunbeam is a registered trademark
of Sunbeam Corporation or its affiliated companies.