

# TURBINE POWERED HUMIDIFIER

Model: TB-1



The TurboMist™ distributes moisture via a rotating foam system powered by air movement in the furnace plenum. The foam pick up water carried in the unit and disperse moisture into the air.

---

**DO NOT DESTROY**

---

THESE INSTRUCTIONS MUST REMAIN WITH EQUIPMENT



**PRODUCT QUESTIONS...  
CALL FIELD FIRST**  
for answers on product maintenance,  
operation or replacement part questions.

☎ Phone: (252)522-3031  
✉ E-mail: [fieldtec@fieldcontrols.com](mailto:fieldtec@fieldcontrols.com)

English .....Page 1  
Français .....Page 5  
Español .....Page 8



**FIELDCONTROLS**  
HOME COMFORT PRODUCTS

2630 Airport Road • Kinston, NC 28504  
Phone: 252-522-3031 • FAX: 252-522-0214  
[www.fieldcontrols.com](http://www.fieldcontrols.com)

**CAUTION:** Do not use the TurboMist™ in a down-flow furnace. (The type where the heated air output is from the bottom of the furnace.)

**INSTALLATION**

Refer to Figure 1 and Figure 2 for suggested humidifier locations. Do not install in a turbulent or dead air space. In installations where more than one humidifier is used do not place them in a position so that one obstructs the air flow of the other.



**WARNING:** Locate the A-COIL before cutting into plenum chamber.

1. Locate the humidifier as close to an existing water pipe as possible. (DO NOT INSTALL SADDLE VALVE on any water pipe which is downstream from a water softener.) Insert baffle if air flow is not directed properly to make turbine and evaporator revolve. See Figure 2
2. Disassemble humidifier: Pull off cover. Remove bagged float valve assembly. Remove pan by lifting up and out. (See Figures 3 & 4)

Refer to Figure 5:

3. Peel backing from template sheet and apply to duct or plenum.
4. See instructions on installation template. Drill four 3/32" dia. Holes. Cut opening in duct as indicated.
5. Use four screws furnished to attach humidifier body to duct. Place level in humidifier body to make sure humidifier is level front to back. Shim with thin metal washers at the front flange as necessary.

Shaded portions indicate dead or turbulent air.

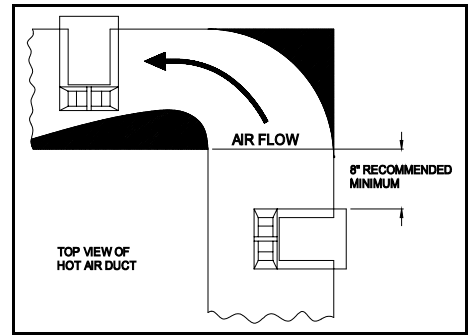

Figure 1

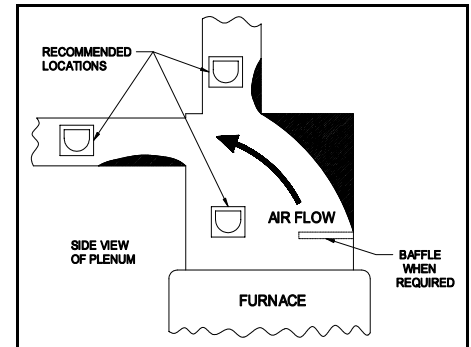

Figure 2

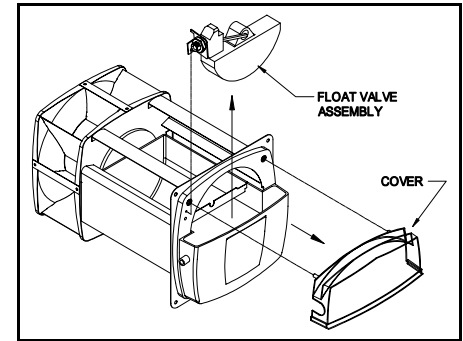

Figure 3

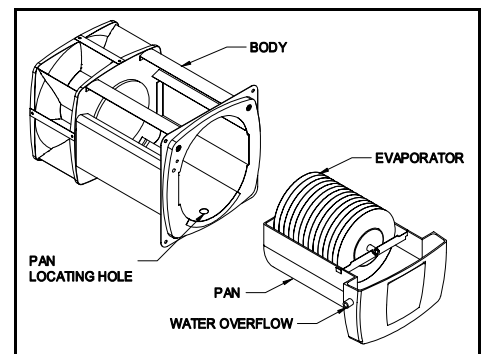

Figure 4

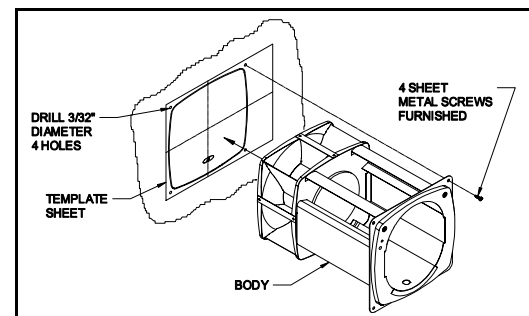

Figure 5

## REASSEMBLE HUMIDIFIER: (FIGURES 6 & 7)

1. Place evaporator assembly and pan into humidifier body making sure evaporator shaft fits into drive hub.
2. Attach float and arm assembly by inserting bracket into mounting hole in the body of humidifier. Insert #8-32 hex head screw provided in bagged hardware and tighten into place.
3. Connect water supply from the saddle valve to the TurboMist™ valve. (Figures 7 & 8)

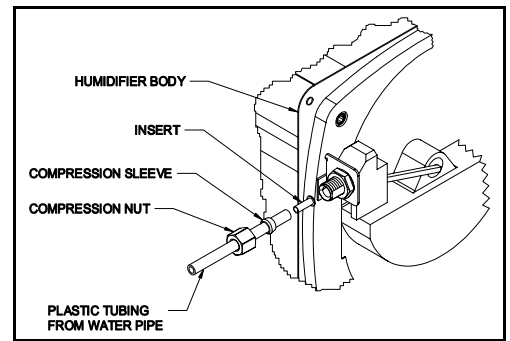

Figure 6

## INSTALLATION OF SADDLE VALVE ON COPPER TUBE (FIGURE 8)

**CAUTION:** Do not turn handle before or while installing the "saddle tapping valve." Be sure the piercing lance does not protrude beyond the rubber gasket. Failure to do this may result in damage to the piercing needle.

1. Assemble the "Saddle Tapping Valve" on copper tube with enclosed bolt and nuts.
2. Tighten bolts evenly and firmly. Brackets should be parallel.
3. Make the water connection to the outlet of the "Saddle Tapping Valve."
4. Turn the handle clockwise until you feel it is firmly seated.

**NOTE:** You have now pierced the copper tube and the valve is closed.

5. After completing all installation steps turn the handle counter-clockwise to open the valve.

**NOTE:** See saddle valve assembly package for additional instructions.

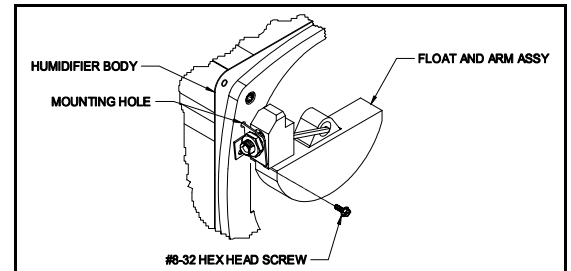

Figure 7

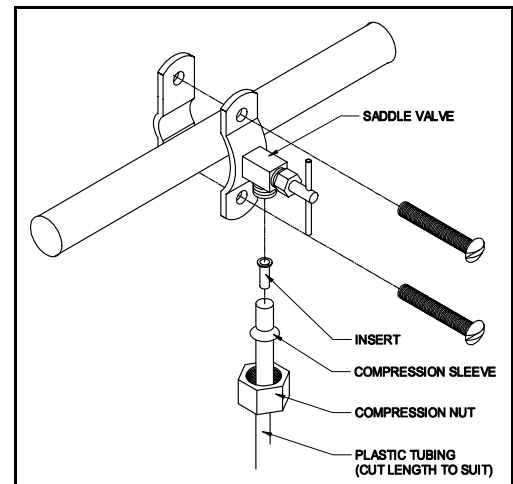

Figure 8

6. Turn water on at saddle valve. Be sure float does not touch any part of the pan and is free to move up and down. The rising and lowering of the float will automatically shut off or replenish the water supply.
7. Check system for leaks. Install front cover.
8. A 1/4" diameter tube should be inserted into the water overflow hole in the pan (See Figure 4) for any excess water drainage.

## **MAINTENANCE**

Your Field TurboMist™ Humidifier puts pure water in the air and traps impurities on the evaporator discs and in the water pan. At the end of each heating season the water pan and float should be cleaned and the saddle valve turned off. Do not use sharp objects or harsh abrasives to clean pan and float.

## **REPLACEMENT PARTS**

The float valve assembly, evaporator assembly and saddle valve assembly can be obtained as replacement parts as necessary. Refer to the diagram below for description.

- For current pricing or to place an order, go to Field Control's website or call Field Control's Customer Service at 252-522-3031.
- VISA and MasterCard orders ONLY. No checks, cash, COD's, or money orders will be accepted.

<b>Accessory Parts List</b>	
Float Valve Assy	46242700
Evaporator Assembly	46244100
Saddle Valve Assembly	46007300
Turbine Assembly	46235700

