

# **DEHUMIDIFIER**

# **USER MANUAL**

Thanks for purchasing the product. Please read the manual carefully before operating.

---

# CONTENTS

Please Note.....	1
Parts Identification.....	1
Control Panel.....	2
To Operate.....	3
To Empty the Bucket when WATER FULL.....	3
To Drain Water.....	4
To clean and Install the Filter.....	4
Compressor self-protection.....	5
Defrosting control.....	5
Installation.....	5
To Move.....	6
To Clean the Unit.....	6
Before Storing.....	6
Troubleshooting.....	7
Specification.....	7

## **Please Note**

1. The unit runs with 115V AC / 60Hz power.
2. Please use a qualified receptacle, and be aware not to share with other electric appliances.
3. Before cleaning, maintenance, non-operated for a long period, please turn power off and unplug the power cord.
4. Please set the unit on flat ground to avoid water leakage, noise of other abnormal situation.
5. Keep a clearance of at least 20cm at the back for air intake and air circulation.
6. Except for refreshing the room air, please have the doors and windows closed, so as to increase the dehumidification efficiency.
7. When moving the unit, be sure to put it gently, avoid hitting, slanting or falling down.

## **Parts Identification**

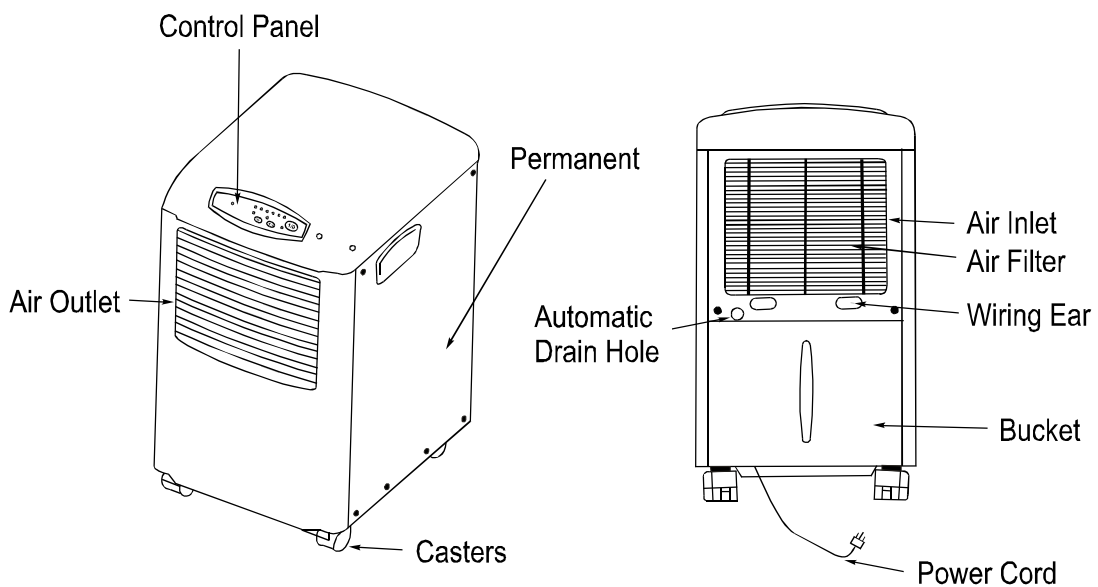

## Control Panel

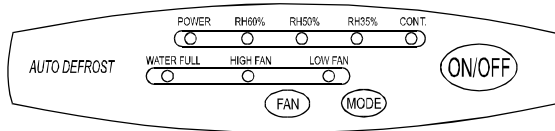

Electronic Type

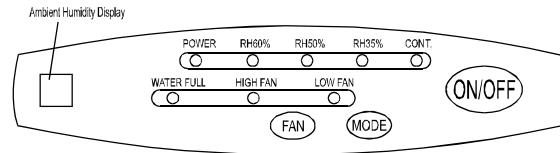

Electronic Type  
(With Ambient Humidity Display)

- ❶ **ON/OFF Button:** When the unit is connected to power for the first time, the POWER indicator will flash slowly. Press the ON/OFF button at this time the unit will Display go into "RH60%" mode. Press ON/OFF button at any time when the unit is in operation, the unit will stop.
- ❷ **MODE Button:** By pressing the MODE button, operating mode of the unit will change in sequence below: (Electronic Type) RH60%→RH50%→RH35%→CONT→RH60%.
- ❸ **FAN Button:** By pressing the FAN button, FAN SPEED will change in sequence below: HIGH FAN→LOW FAN→HIGH FAN
- ❹ **POWER Indicator:** Blinks at 0.5Hz when the power is connected. The POWER Indicator lights after the unit is turned on, and dark after the unit is turned off. When Temperature sensor malfunction occurs, it blinks at 5Hz.
- ❺ **WATER FULL:** Lights when the bucket is full.
- ❻ **"RH60%" Indicator:** Lights when the unit is on RH60% mode (Relative Humidity is 70% or more; Both compressor and fan are on. Relative Humidity is below 60%, both the compressor and the fan are off.)
- ❼ **"RH50%" Indicator:** Lights when the unit is on RH50% mode (Relative Humidity is 60% or more; Both compressor and fan are on. Relative Humidity is below 50%, both the compressor and the fan are off.)
- ❽ **"RH35%" Indicator:** Lights when the unit is on RH35% mode (Relative Humidity is 50% or more; Both compressor and fan are on. Relative Humidity is below 35%, both the compressor and the fan are off.)
- ❾ **CONT. Indicator:** Lights when the unit is on CONTINUOUS DEHUMIDIFYING mode. Compressor and fan are on.
- ❿ **HIGH FAN Indicator:** Lights when HIGH FAN is selected.
- ⓫ **LOW FAN Indicator:** Lights when LOW FAN is selected.

## To Operate

1. Plug the cord to the proper power requirement. The computer system of the unit will have a self-check. If it is normal, the "POWER" indicator flashes at 0.5 Hz. Press "ON/OFF" button now, the unit will start operating under "RH60%" mode.
2. Press the mode selection key to choose mode orderly. The unit will run according to these function.
3. Make sure to fit the bucket in right position. (When the bucket is full or is not in place, the "WATER FULL" blinks and the machine stops.)
4. Press the "ON/OFF" button to turn off the machine. (You don't need to unplug the power cord except when the unit will not be in use for a long period of time.)

## To Empty the Bucket when WATER FULL

1. When the bucket is full, "WATER FULL" blinks. The machine stops.
2. Don't remove the bucket immediately as the machine is still working or just stopping. This might cause some water dripping.
3. For pouring out the water, drag out the bucket, keep it balance and lift it up with its handle.
4. After pouring out the water, clean the bucket and restore in place.
5. Return the clean bucket WATER FULL indicator turns dark. Then the unit continues running.

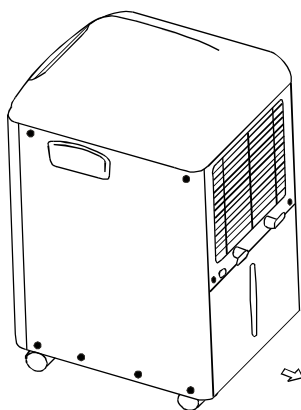

1. Drag out the bucket a little.

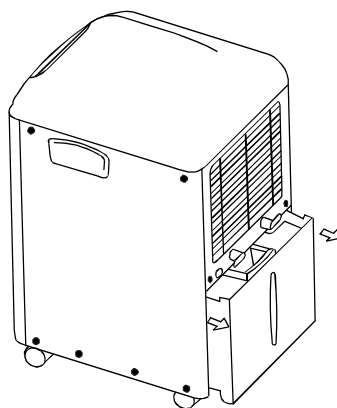

2. Hold the two sides of the bucket with even strength, and pull it out from the unit.

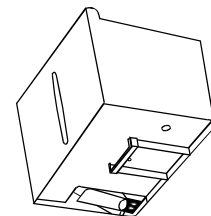

3. Pour the water out.

## To Drain Water

You may use a hose with an inner diameter of 11.5 mm (0.45 inch) for continuous drainage:

1. Use a screw driver or so to remove the pick-out at the back (don't use hand or may get injury), then push the hose to a connector inside the hole.
2. The hose should go down smoothly with no bends.

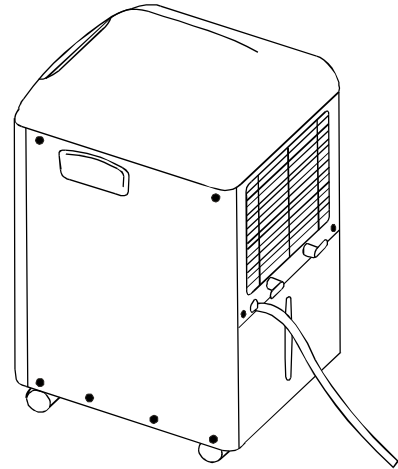

## To Clean and Install the Filter

If the filter is covered by a plenty of dust, the airflow and the performance of the unit will be affected badly. It is recommended to check and clean the air filter every 2 weeks.

1. Turn off the machine, pull out the bucket. There is a handle of the filter under the air inlet grille. When pulling out the filter, please push it a little bit inwards and then take it out downwards.
2. Wash the nylon filter with clean water. Then dry or vacuum it.
3. Install the cleaned Filter following chart C below.

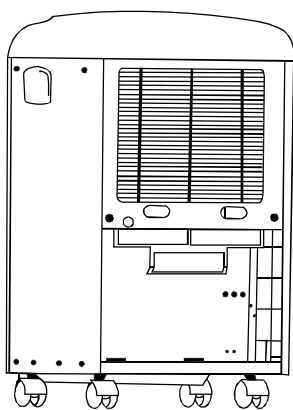

Push in and pull down the air filter handle

Chart A

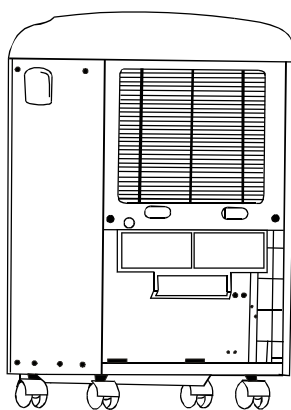

Pull the air filter out

Chart B

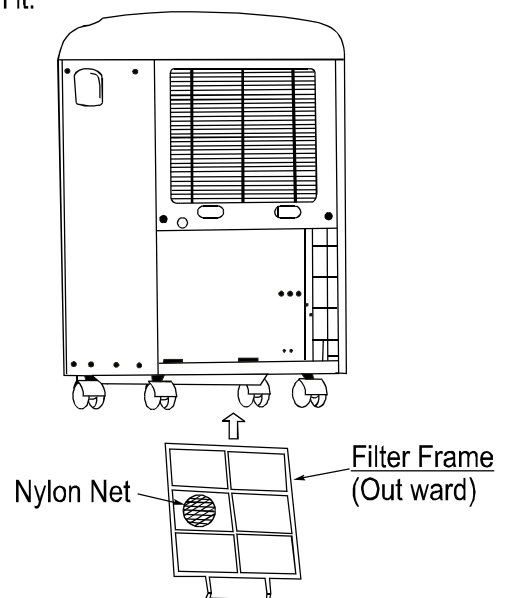

Install air filter

Chart C

## ***Compressor self-protection***

The unit has a Compressor Automatic Delay Protection feature. The compressor will restart at least 3 minutes later after it stops for self-protection.

## ***Defrosting control***

Automatic Defrosting Device is controlled by microcomputer to ensure that the dehumidifier work normally at 5°C temperature or higher (room temperature).

## ***Installation***

Please set the unit on flat ground to avoid water leakage, loosen, noise or other abnormal situation.

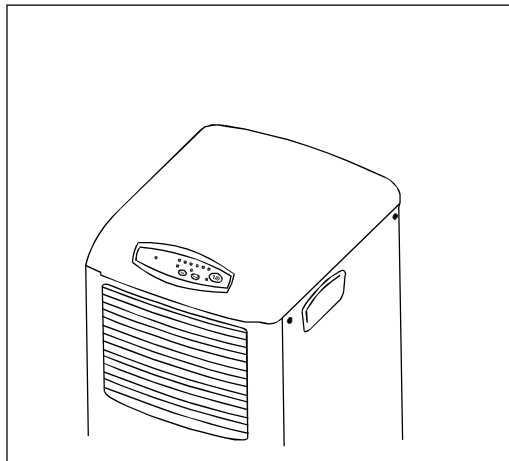

Keep a clearance of at least 20cm at the back for air intake and air circulation.

## ***To Move***

1. Unplug the cord and empty the water bucket before moving the unit.
2. Bottom casters are provided to allow you to move the unit easily from one place to another. For moving upstairs or downstairs, lift it by two persons by holding at the bottom and settle it carefully.
3. Before operating the unit, make sure the bucket is well in place.

## ***To Clean the Unit***

1. Air inlet and outlet may gather dust easily, please have it clean often with a soft cotton cloth.
2. Please use cloth with soft detergent to clean the unit.
3. In order to avoid damage, do not wash the machine with water.

## ***Before Storing***

1. Clean and dry the bucket.
2. Clean the nylon filter, the inlet, the outlet and the unit.
3. Cover the unit to prevent it from gathering dust. Store it in a cool and dry place.



## Troubleshooting

Problem	Cause	Remedy
Fail to run	<ol style="list-style-type: none"> <li>1. Power off</li> <li>2. Power cord unplugged</li> <li>3. Bucket displaced or water is full</li> <li>4. Defrosting</li> </ol>	Power on Restore power cord Position bucket and pour out water After defrosting, the unit will auto-return to dehumidifying
Performance Decreased	<ol style="list-style-type: none"> <li>1. Blocks in nylon filter</li> <li>2. Room windows opened</li> <li>3. Obstacles in outlet or inlet</li> </ol>	Wash nylon filter Close room windows and doors Clean the obstacles
Big Noise	<ol style="list-style-type: none"> <li>1. Unstable setting of unit</li> <li>2. Block in filter</li> </ol>	To reset the unit Clean the nylon filter

**Please contact your dealer if there is still a problem.**

**Do not try to repair it by yourself.**

## Specification

Model	MDB-25AE	MDB-40AE	MDB-65AE
Dehumidification	25pints/d	40pints/d	65pints/d
Power	115V~ 60Hz		
Current	3.9A	4.5A	6.3A
Power consumption	370W	510W	730W
Working Environment	5~35°C		
	25% RH above		
Bucket volume	8L		
Net weight	24kg	25kg	
Product size	H635 W350 D425mm		

## Air Conditioner Warranty

Your product is protected by this warranty:

Warranty service must be obtained from Midea Consumer Services or an authorized Midea servicer.

	WARRANTY PERIOD	MIDEA, THROUGH ITS AUTHORIZED SERVICERS, WILL:	THE CONSUMER WILL BE RESPONSIBLE FOR:
FULL ONE-YEAR WARRANTY	One year from original purchase date	Pay all costs for repairing or replacing parts of this appliance which prove to be defective in materials or workmanship.	Costs of service calls that are listed under <b>NORMAL RESPONSIBILITIES OF THE CONSUMER*</b>
LIMITED 2ND-5TH YEAR WARRANTY (sealed system)	Second through fifth years from original purchase date	Repair or replace any parts in the Sealed Refrigeration System (compressor, condenser, evaporator and tubing) proves to be defective in materials workmanship.	Diagnostic, removal, transportation and reinstallation costs required because of service.  Costs for labor, parts and transportation other than with respect to the Sealed Refrigeration System.

**Midea replacement parts shall be used and will be warranted only for the period remaining on the original warranty.**

### NORMAL RESPONSIBILITIES OF THE CONSUMER\*

**This warranty applies only to products in ordinary household use, and the consumer is responsible for the items listed below:**

1. Proper use of the appliance in accordance with instructions provided with the product.
2. Proper installation by an authorized service professional in accordance with instructions provided with the appliance and in accordance with all local plumbing, electrical and / or gas codes.
3. Proper connection to a grounded power supply of sufficient voltage, replacement of blown fuses, repair of loosen connections or defects in house wiring.
4. Expenses for making the appliance accessible for servicing.
5. Damages to finish after installation.

### EXCLUSIONS

**This warranty does not cover the following:**

- 1) Failure caused by damage to the unit while in your possession (other than damage caused by defect or malfunction), by its improper installation, or by unreasonable use of the unit, including without limitation, failure to provide reasonable and necessary maintenance or to follow the written Installation and Operating Instructions.
- 2) Damages caused by services performed by persons other than authorized Midea servicers; use of parts other than Midea replacement parts; obtained from persons other than such Midea customer service; or external causes such as abuse, misuse, inadequate power supply or acts of God.
- 3) If the unit is put to commercial, business, rental, or other use or application other than for consumer use, we make no warranties, express or implied, including but not limited to, any implied warranty of merchantability or fitness for particular use or purpose.
- 4) Products without original serial numbers or products that have serial numbers which have been altered or cannot be readily determined.

Note: Some states do not allow the exclusion or limitation of incidental or consequential damages. So this limitation or exclusion may not apply to you.

### IF YOU NEED SERVICE

Keep your bill of sale, delivery slip, or some other appropriate payment record.

The date on the bill established the warranty period should service be required.

If service is performed, it is your best interest to obtain and keep all receipts.

This written warranty gives you specific legal rights. You may also have other rights that vary from state to state.

Service under this warranty must be obtained by following these steps, in order:

1. Contact Midea Consumer Services or an authorized Midea servicer at 1 866 64 MIDEA.
2. If there is a question as to where to obtain service, contact our consumer relations Department.