



INSTALLER: PLEASE FILL OUT AND MAIL GUARANTEE CARD AFTER INSTALLATION IS COMPLETE. LEAVE INSTALLATION INSTRUCTIONS WITH HOME OWNER

1000 SERIES FLOW THROUGH POWER HUMIDIFIER

FOR INSTALLATION ON A VERTICAL SURFACE OF THE WARM AIR PLENUM OF ANY FORCED AIR FURNACE

PRECAUTION: The installer should be an experienced service technician. Disconnect electrical power before beginning installation. Do not install where temperatures fall below 32 degrees F or where plenum temperatures exceed 200 degrees F. For maximum evaporative capacity, install this humidifier on the warm air supply plenum. When wiring into a multi-speed blower circuit see Step 6C & 6D.

ADDITIONAL MATERIALS THAT MAY BE NECESSARY:

1. 1/4" diameter plastic supply tubing or 1/4" copper supply tubing for hot water applications
2. air pressure switch (G.F. Model #12500 suggested)

3. junction box, 115 V. grounding outlet, cover and wire
4. 1/2" I.D. drain hose
5. #8 x 3/4" mounting screws

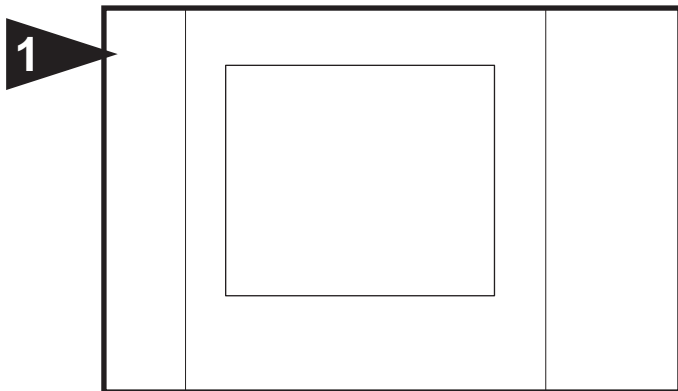

Select location on vertical surface of warm air plenum for mounting humidifier. Tape mounting template in place making sure the template is level. Do not install humidifier where the blanked off ends of a cooling coil will restrict air flow to the humidifier. Cut out center section of template.

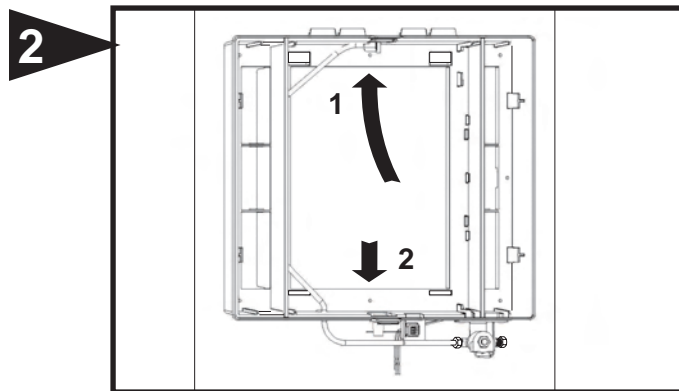

Open cover and remove evaporator pad assembly. Humidifier chassis is self retaining, slide top side in first then slide chassis down. Level chassis and install eight screws.

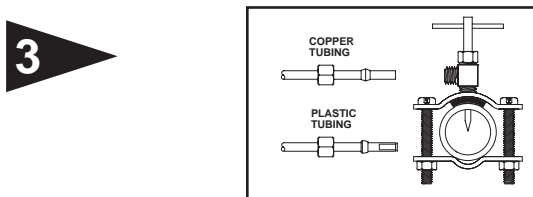

Mount the self tapping saddle valve on either a cold or a hot water pipe. A side or top mount is best to avoid clogging from pipe sediment. Connect 1/4" O.D. tubing to the saddle valve. Copper tubing requires a brass compression nut and brass sleeve. Plastic tubing requires a brass insert inside the tubing, a plastic sleeve on the outside with a brass compression nut.

NOTE: DO NOT USE PLASTIC TUBING ON HOT WATER OR IN CONTACT WITH ANY HOT PLENUM SURFACE OR DUCT. INSTALLATION OF THIS SADDLE VALVE MUST MEET OR EXCEED LOCAL CODES AND ORDINANCES.

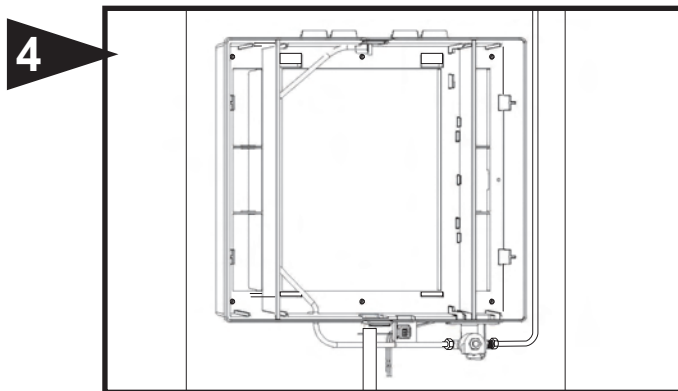

Connect 1/4" water supply tube to inlet of solenoid. **DO NOT USE PLASTIC TUBING IN CONTACT WITH ANY HOT PLENUM SURFACE OR DUCT. IF USING PLASTIC TUBING, USE TUBE SUPPORT P189 AND PLASTIC COMPRESSION SLEEVE P190.**

Connect drain hose to 1/2" spout on humidifier cabinet using hose clamp if necessary. Run 1/2" hose to suitable drain such as floor drain, sewer or laundry sink. Be sure hose has continuous slope and is not kinked at any point.

SADDLE VALVE INSTALLATION INSTRUCTIONS

Copper Pipe

1. Retract piercing pin into valve body by turning handle counterclockwise.
2. Screw valve body into upper bracket and tighten.
3. Place rubber gasket over piercing pin.
4. Assemble saddle valve over copper pipe using enclosed screen, nuts and lower bracket.
5. Tighten screws evenly and firmly. Brackets should be parallel.
6. Complete compression connection to saddle valve outlet.
7. Turn handle clockwise to pierce tubing and close saddle valve.
8. Turn handle counterclockwise to open saddle valve, leave open for several seconds to flush dirt from pipe and tubing.

Steel, Brass or Hard Plastic Pipe

1. Shut off water supply and drain pipe.
2. Turn handle clockwise to expose piercing pin and close saddle valve.
3. Place rubber gasket over piercing pin.
4. Drill 1/8" hole in pipe using a hand crank drill to avoid shock hazard.
5. Assemble saddle valve over steel, brass or hard plastic pipe using enclosed screws, nuts and lower bracket.
6. Tighten screws evenly and firmly. Brackets should be parallel.
7. Complete compression connection to saddle valve outlet.
8. Turn handle counterclockwise to open saddle valve, leave open for several seconds to flush dirt from pipe and tubing.

Threaded Pipe Fittings

1. Turn handle clockwise to expose piercing pin and close saddle valve.
2. Seal valve body threads using pipe tape or sealant.
3. Install valve into 1/8" NPT fitting.
4. Complete compression connection to saddle valve outlet.
5. Turn handle counterclockwise to open saddle valve, leave open for several seconds to flush dirt from pipe and tubing.

5

E2 HUMIDISTAT

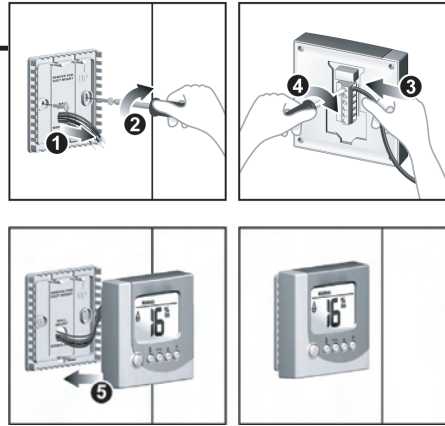
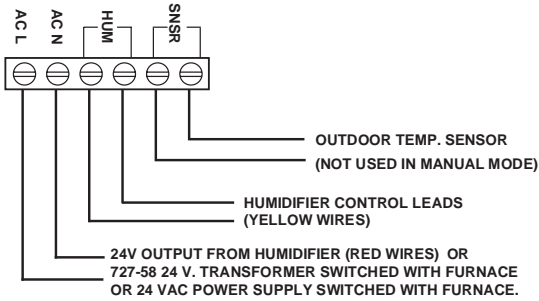

1. Follow the installation instructions supplied with the humidistat.
2. To remove the humidistat from the base, squeeze the louvered base at the top and bottom.
3. Before wall mounting, please remove the gasket.
4. Before return air duct mounting, please remove the breakout piece.

6

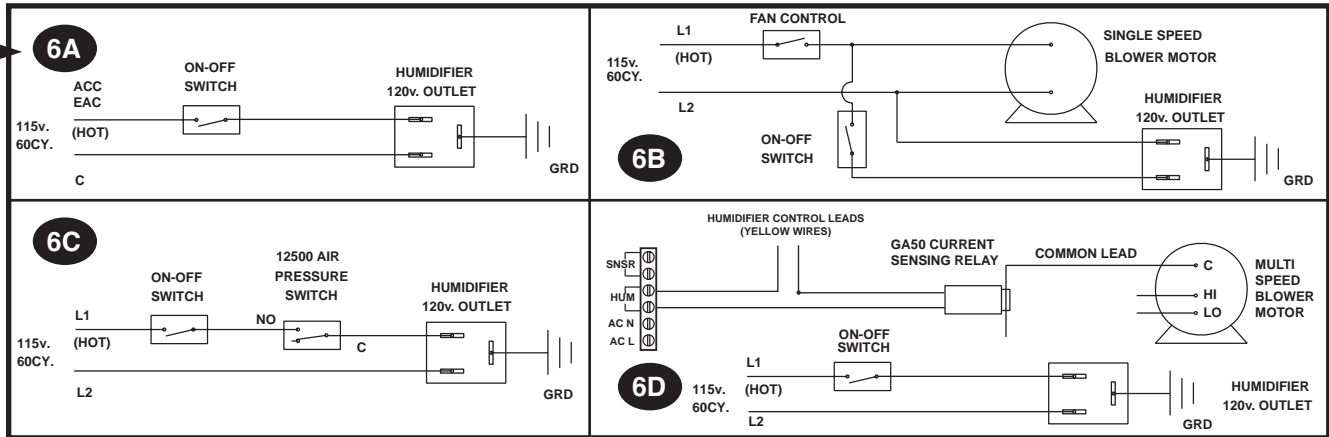

INSTRUCTIONS FOR WIRING HUMIDIFIER

FIG. 6A WITH FURNACE CIRCUIT BOARD

On furnaces with output terminals ACC, or EAC check output voltage to determine that terminals are 115V. Connect on-off switch in series with the hot wire.

NOTE: ALL WIRING SHOULD COMPLY WITH LOCAL ELECTRICAL CODES.

FIG. 6B WITH SINGLE SPEED BLOWER MOTOR

On furnaces with single speed blowers, mount a junction box and 115v. grounded outlet connected in parallel with the blower circuit. Connect the on-off switch in series with the hot or black wire.

FIG. 6C WITH TWO SPEED BLOWER MOTOR

On furnaces with a two speed blower, the humidifier and a Model 12500 Air Pressure Switch may be wired from a continuous 115 volt power source. Install the on/off switch and Air Pressure Switch in series with the hot or black wire. The Air Pressure Switch will detect furnace operation and supply power to the humidifier accordingly.

FIG. 6D WITH TWO SPEED BLOWER MOTOR

On furnaces with a two speed blower, the humidifier may be wired from a continuous 115 volt power source. Install the on/off switch in series with the hot or black wire. Install the GA50 Current Sensing Relay in series with the humidistat circuit. The Current Sensing Relay will detect furnace operation and supply power to the humidifier accordingly.

CIRCUIT DESCRIPTION

The humidifier is connected to the 120 volt AC circuit through a control relay. The secondary coil of an isolation transformer, a diode and resistor supply 24 volts DC for the control circuit which also includes the humidistat and relay coil. When the control circuit is completed by the humidistat, the relay closes, supplying 120 volts to the fan motor and 24 volts to the solenoid valve.

7

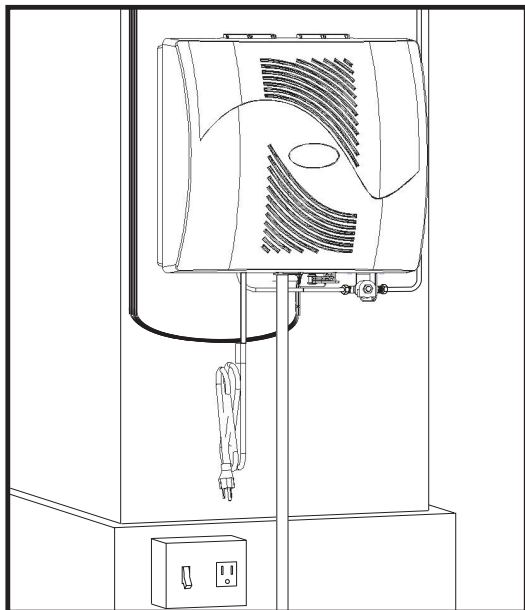

Replace evaporator pad assembly and humidifier cover. Insert low voltage six connector wiring harness from cover into chassis solenoid harness.

8

Turn on water supply and plug in power cord to check operation of humidifier. Set humidistat to a demand setting. With the furnace off, the solenoid valve should be closed and the humidifier fan not running. Start the furnace, the solenoid valve should open and the humidifier fan run when the blower or burner circuit is energized. Check flow of water through distributor trough and evaporator pad. The standard GA4231 yellow orifice will supply approximately 3.5 GPH of water at a line water pressure of 60 psi. For low water pressures (20-40 psi) a larger orifice GA4299 is available to provide the same flow. Leave humidistat set at the recommended setting.

PARTS LIST FOR HUMIDIFIER

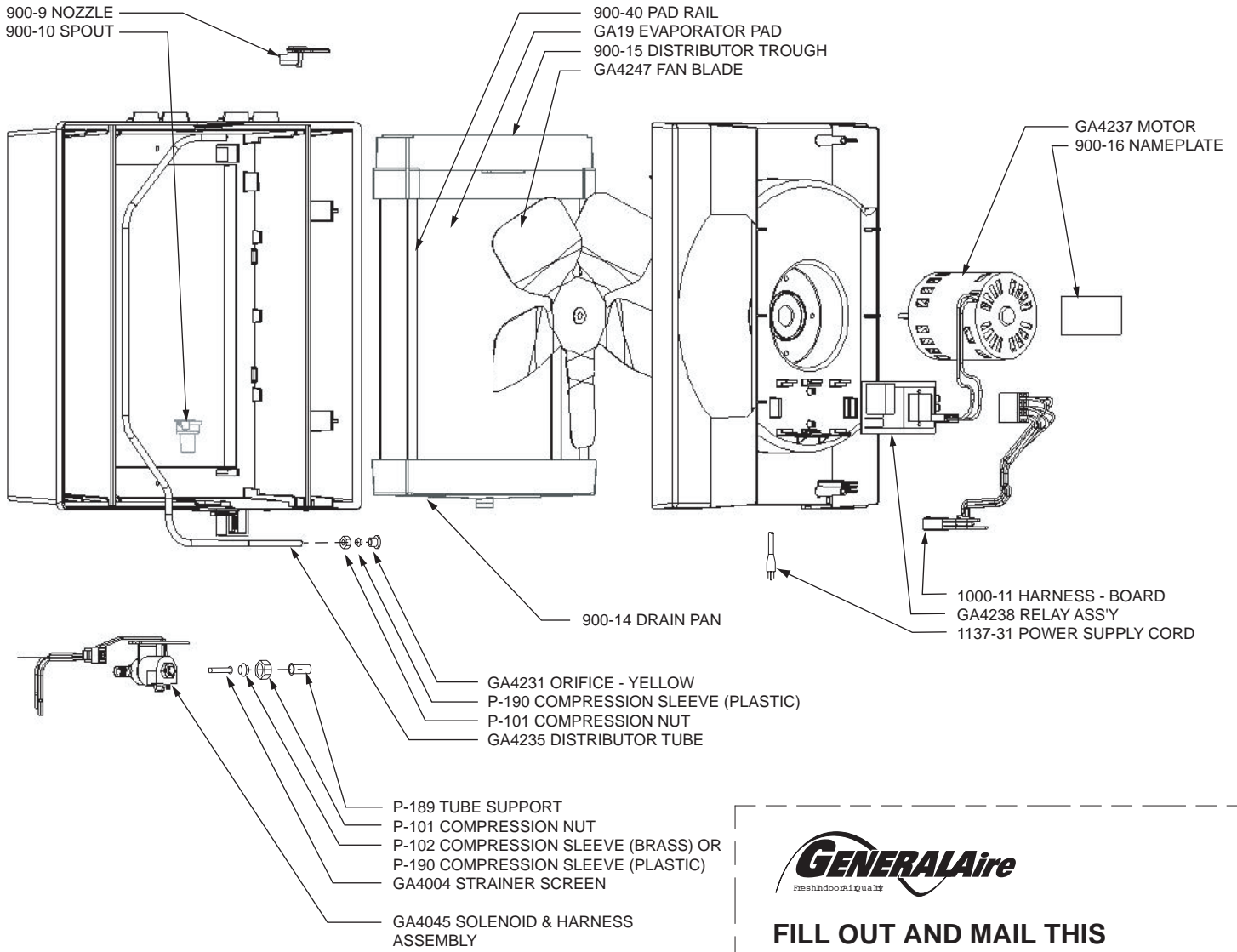

**FILL OUT AND MAIL THIS
WARRANTY CARD AND
LITERATURE REQUEST FORM**

- AIR CLEANERS AND AIR PURIFIERS
- HUMIDIFIERS
- DIGITAL HUMIDITY GAGE
- AIR FILTER GAGE
- FUEL OIL FILTERS AND ACCESSORIES

LIMITED WARRANTY

This humidifier, if properly registered by the return of the warranty registration card to the manufacturer, is warranted to the consumer against defects in materials and workmanship for a period of ten years from the date of installation. Evaporator pads, water strainers or metering orifices are not covered by this limited warranty or any other warranties. Any other defective parts will be repaired without charge except for removal, reinstallation and transportation costs. To obtain repair service under this limited warranty, the consumer must send the defective part or the complete humidifier to the manufacturer.

THERE ARE NO EXPRESS WARRANTIES COVERING THIS AIR CLEANER OTHER THAN AS SET FORTH ABOVE, THE IMPLIED WARRANTIES OF MERCHANTABILITY AND FITNESS FOR A PARTICULAR PURPOSE ARE EXPRESSLY EXCLUDED. THE MANUFACTURER ASSUMES NO LIABILITY IN CONNECTION WITH THE INSTALLATION OR USE OF THIS PRODUCT, EXCEPT AS STATED IN THIS LIMITED WARRANTY. THE MANUFACTURER WILL IN NO EVENT BE LIABLE FOR INCIDENTAL OR CONSEQUENTIAL DAMAGES.

This limited warranty gives you specific legal rights, and you may also have other rights which vary from state to state. Some states do not allow either limitations on implied warranties, or exclusions from incidental or consequential damages, so the above exclusion and limitation may not apply to you.

Any questions pertaining to this limited warranty should be addressed to the manufacturer. (U.S.A.: The manufacturer has elected not to make available the informal dispute settlement mechanism which is specified in the Magnuson-Moss Warranty Act.)

GENERAL FILTERS, INC.
NOVI, MICHIGAN 48375-1115
WWW.GENERALAIRE.COM

CANADIAN GENERAL FILTERS, LTD.
SCARBOROUGH, ONTARIO M1R3B7
WWW.CGFPRODUCTS.COM

CARE AND MAINTENANCE

Your Humidifier is engineered to give helpful and trouble-free humidification. For maximum efficiency the following cleaning procedures should be carried out at the end of each heating season:

1. Turn off water supply and electrical power to humidifier.
2. Remove cover, water distributor trough, evaporator pad, pad rails and drain pan. Clean excessive mineral deposits from the distributor trough, drain pan, pad rails and humidifier cabinet. A solution of 1/2 vinegar & 1/2 water will help loosen mineral deposits. Inspect drain hose, clean or replace as necessary.
3. If the evaporator pad has excessive mineral deposits, replace with a new "GA19" evaporator pad. Install trough, pad rails and drain pan. Replace cover, reconnect electrical plug..
4. In heavy mineral areas or if the solenoid valve fails to function disconnect the 1/4" water supply line from the solenoid valve. Carefully pull the strainer screen (P.N. 900-8) from the valve body (P.N. 900-6). Clean the mineral deposits from all parts. If the orifice is clogged, it may be opened by inserting a small pin. Reinsert the filter into the valve body.
5. Reconnect the 1/4" water line to the solenoid valve if necessary. Turn on the water supply and check all points for leakage. The operation of the unit may be checked by starting the furnace. The humidifier operates only when the furnace blower is running or the burner circuit is energized. The humidifier is now ready for operation.
6. During the summer, turn off water supply and electrical power to humidifier.

AT OUTSIDE TEMPERATURE	RECOMMENDED SETTING
-20°F -29°C	15%
-10°F -23°C	20%
0°F -18°C	25%
+10°F -29°C	30%
+20°F -7°C	35%
+30°F -1°C	40%

HOW THE HUMIDIFIER WORKS

The operating principle of the humidifier is based on the most efficient and economical means of evaporating water to the air. The heat necessary for evaporating water is produced by the furnace.

The water supply to the humidifier is controlled by the electric solenoid valve. The solenoid valve and humidifier fan are controlled by a humidistat connected through an isolation relay. The humidistat is designed for wall mounting in the living area or surface mounting on the return air duct. ELECTRICAL RATING: 24 VAC/ 60 Hz.

DO NOT SET RELATIVE HUMIDITY TOO HIGH DURING COLD WEATHER. EXCESSIVE HUMIDITY MAY CAUSE CONDENSATION ON WINDOWS OR IN WALLS. REFER TO RECOMMENDED SETTINGS AS DESCRIBED IN THE HUMIDISTAT OWNERS MANUAL.

Water flows through a strainer, is metered through an orifice to provide the proper amount of water, and is supplied to the evaporator pad by the distributor trough. Air from the warm air plenum is pulled through the wetted evaporator pad by the humidifier fan and returned to the warm air plenum to be circulated through the living area. Moisture is evaporated to the air passing through the evaporator pad.

Minerals are not blown into the air stream as occurs in atomizing humidifiers; they are left on the evaporator pad where a high percentage is carried off with the waste water.

When the humidifier is installed and operating, no adjustments are necessary other than setting the control knob on the humidistat to the desired level of humidification.

To turn the humidifier off, close water supply valve, switch electrical power off and turn humidistat off.

**AU PROPRIÉTAIRE : INSCRIVEZ-VOUS EN LIGNEAU
WWW.GENERALAIRE.COM OU REMPLISSEZ LA CARTE
D'ENREGISTREMENT PUIS POSTEZ-LA A L'ADRESSE SUIVANTE :
OWNER REGISTER ONLINE AT
WWW.GENERALAIRE.COM OR
FILL IN REGISTRATION AND MAIL TO:**

GENERAL FILTERS, INC.
43800 GRAND RIVER AVE
NOVI, MI 48375-1115

WARRANTY REGISTRATION Enregistrement de la garantie

MODEL 1000
MODELE 1000

OWNER'S NAME
Nom du propriétaire: _____

STREET ADDRESS
Adresse: _____

CITY
VILLE: _____

STATE
PROVINCE: _____

DEALER'S NAME
Nom du marchand: _____

STREET ADDRESS
Adresse: _____

CITY
VILLE: _____

STATE
PROVINCE: _____

DATE OF INSTALLATION
DATE DE INSTALLATION _____

SERIAL NUMBER
NUMÉRO DE SÉRIE _____

POSTAL CODE
Code postal: _____

POSTAL CODE
Code postal: _____

POSTAL CODE
Code postal: _____

POSTAL CODE
Code postal: _____

POSTAL CODE
Code postal: _____

POSTAL CODE
Code postal: _____

POSTAL CODE
Code postal: _____