

**CAUTION: READ ALL INSTRUCTIONS CAREFULLY BEFORE INSTALLATION.
SAVE THIS OWNER'S MANUAL FOR FUTURE REFERENCE.**

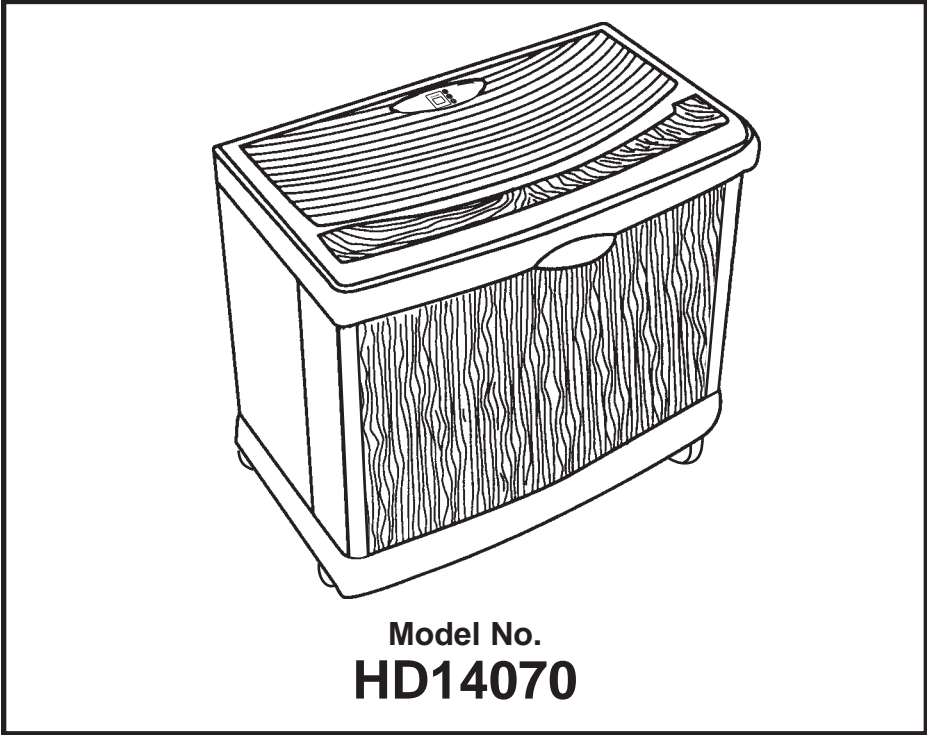

MoistAIR[®]_{MD}

EMERSON[®]

HD14070 Evaporative Console Humidifier Owner's Manual

Limited Warranty

This product is warranted against defects in workmanship and materials for one year from the date of sale except for motors, which are warranted for two years. This warranty does not apply to damage from accident, misuse, alteration, unauthorized repairs, unauthorized use, mishandling, unreasonable use, abuse, including failure to perform reasonable maintenance, normal wear and tear, nor where the connected voltage is more than 5% above the nameplate voltage, nor to the equipment or products being improperly installed or wired or maintained in violation of this Owner's Manual. THIS WARRANTY DOES NOT APPLY TO FILTERS WHICH ARE CUSTOMER REPLACEABLE PARTS. THIS PRODUCT IS NOT INTENDED FOR COMMERCIAL USE. THIS IS THE SOLE AND EXCLUSIVE WARRANTY GIVEN BY MANUFACTURER WITH RESPECT TO THE PRODUCTS AND, TO THE MAXIMUM EXTENT PERMITTED BY LAW, IS IN LIEU OF AND EXCLUDES ALL OTHER WARRANTIES AND CONDITIONS, EXPRESS OR IMPLIED, ARISING BY OPERATION OF LAW OR OTHERWISE, INCLUDING WITHOUT LIMITATION, MERCHANTABILITY AND/OR FITNESS FOR A PARTICULAR PURPOSE. No employee, agent, dealer or other person is authorized to give any warranties or conditions on behalf of the manufacturer. The customer shall be responsible for all costs incurred in the removal or reinstallation and shipping of the product for repairs.

Within the limitations of this warranty, inoperative units should be returned, with a copy of the sales receipt, freight prepaid to an authorized repair service center and the manufacturer will repair or replace the product, at its option, at no charge to the customer with return freight paid by the manufacturer. It is agreed that such repair or replacement is the exclusive remedy available from the manufacturer and that TO THE MAXIMUM EXTENT PERMITTED BY LAW, THE MANUFACTURER IS NOT RESPONSIBLE FOR DAMAGES OF ANY KIND, INCLUDING INCIDENTAL AND CONSEQUENTIAL DAMAGE OR LOSS OF PROFITS OR REVENUES. Some provinces and states do not allow the exclusion or limitation of incidental or consequential damages, so the above exclusion or limitation may not apply in some cases.

The warranty gives the customer specific legal rights, and the customer may also have other rights which vary from province to province, or state to state.

SALES RECEIPT REQUIRED AS PROOF OF PURCHASE FOR WARRANTY CLAIMS.

GENERAL SAFETY INSTRUCTIONS

Safety Signal Words

DANGER: means if the safety information is not followed someone **will** be seriously injured or killed.

WARNING: means if the safety information is not followed someone **could** be seriously injured or killed.

CAUTION: means if the safety information is not followed someone may be injured.

1. To reduce the risk of fire or shock hazard, plug humidifier directly into a 120V, A.C. electrical outlet. Do not use extension cords.
2. Keep the electric cord out of traffic areas. To reduce the risk of fire hazard, never put the electric cord under rugs, near heat registers, radiators, stoves or heaters.
3. Always unplug the humidifier before moving it, removing the fan assembly section, before cleaning, or whenever the humidifier is not in service.
4. Keep the humidifier clean.

5. Do not put foreign objects inside the humidifier.
6. Do not allow to be used as a toy. Close attention is necessary when used by or near children.
7. Never use your humidifier while any part is missing or damaged in any manner.
8. To reduce the risk of electrical hazard or damage to humidifier, do not tilt, jolt or tip humidifier while unit is running.
9. To reduce the risk of damage to humidifier, unplug when not in use.
10. To reduce the risk of accidental electrical shock, do not touch the cord or controls with wet hands.
11. Note the warning label shown below.

WARNING: To reduce risk of fire, electric shock, or injury always unplug before servicing or cleaning.

Know Your Humidifier

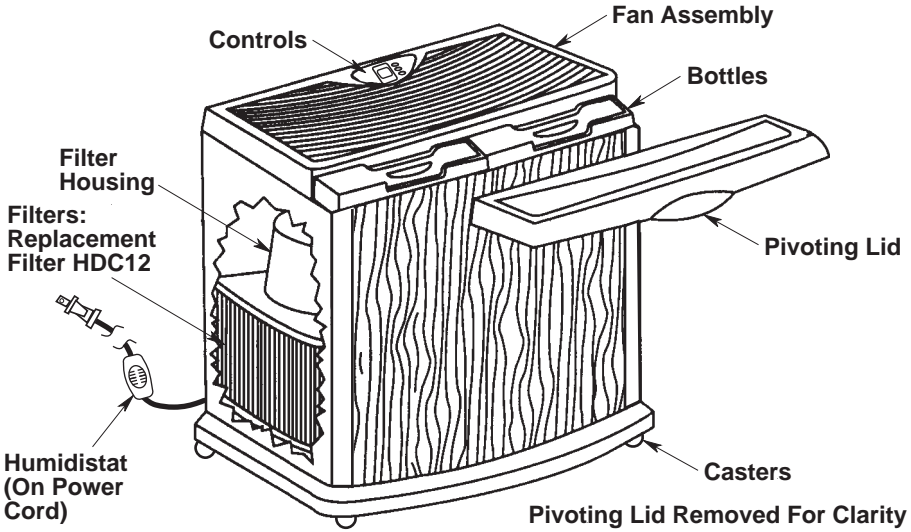

Description	HD14070
* Output/24 hrs	14 Gallons/53 Litres
Capacity of Bottle	2-3/8 Gallons/9 Litres
* Sq. Ft. Coverage	2900
Fan Speeds	3
Auto Fan Speed	Yes
Replacement Filter	Set of 4 (HDC12)
Refill Indicator	Yes
Auto Shut Off	Yes
Auto Humidistat	Yes
Controls	Electronic (Push Button)
Casters	Yes (4)
UL Listed	Yes
Volts	120 A.C.
Hertz	60
Amps	2.88
Watts	165

* Based on an area with average insulation and an 8' ceiling height ANSI/AHAM HU-1-1997. SEC. 8.1, results may vary.

How Your Humidifier Works

Your new MoistAIR humidifier is designed to satisfy home humidity requirements through the principle of evaporation of water into the air.

After water is added to the bottle, the filters begin to soak up the water and become totally saturated in approximately 30 minutes. Air is drawn in from the rear of the humidifier and through the filters by means of circulation fans. As air passes through the filters, moisture is absorbed into the air and then released in the form of vapor. No water droplets will enter the home. All evaporation into the air takes place in the humidifier, which means that the residue left by evaporating water is not passed into the home, but remains in the filter.

CAUTION: Use only EPA Registered Bacteriostat. Under no circumstances should you use water treatment products designed for Roto belt or Ultrasonic humidifiers.

Humidified Air is Then Released Through the Top

Dry Air Enters Through the Rear

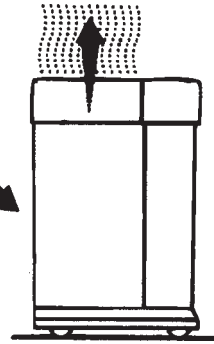

CAUTION: To reduce the risk of injury, fire or damage to humidifier, use only cleaners specifically recommended for humidifiers. Never use flammable, combustible or poisonous materials to clean your humidifier.

To reduce the risk of scalds and damage to humidifier, never put hot water in humidifier.

Assembly

Your new MoistAIR humidifier is completely assembled for you to use. Remove the bag pack containing two plastic caster pads from top of humidifier and retain for future use if required. See the following Step 1 for instructions.

Remove the packaging material from inside your humidifier and follow the instructions of this operator's manual for proper usage. The packaging material is located under the fan assembly. Remove the packaging material and discard.

Location Instructions

WARNING: For your own safety, do not use humidifier if any parts are damaged or missing.

Step 1:

Place humidifier on a flat level surface in an area of your house where humidity is needed most, or in an area which would likely result in moist air being circulated throughout the house, such as near a cold air return.

Placing the unit level is very important if the humidifier is located on carpeting.

NOTE: The humidifier contains water bottles. The weight of the bottles in the front of the cabinet may cause the front casters to sink deeper into the carpet. If this happens, the water level will be higher towards the front of the humidifier, and lower towards the back. The water level float (located at the rear of the cabinet) may not sense the water so the flashing "F" will be displayed and the unit will not energize. If this happens, the unit will need to be leveled in order for the humidifier to be energized. To level the humidifier when located on carpet, place the included caster pads under the front two casters of the humidifier only.

NOTE: Due to release of cool, moist air from humidifier, it is best to direct air away from home thermostat and hot air registers. It is best to position humidifier

next to an inside wall. Hot air registers and cold air from outside walls can affect the efficiencies of the controls. Unit should not be placed where warm air from a hot air register blows directly on unit.

Moist air (humidity) produced will disperse into the whole house, but area closest to the unit will have the highest humidity. If the unit is positioned close to a window, condensation may form on the window pane. If this is not appropriate the unit should be repositioned in another location.

Step 2:

The humidifier should be positioned with the back (cord exit side), at least 5 centimeters away from the wall.

Air needs to enter through the louvers in the rear panel in order for the humidifier to operate at peak efficiency.

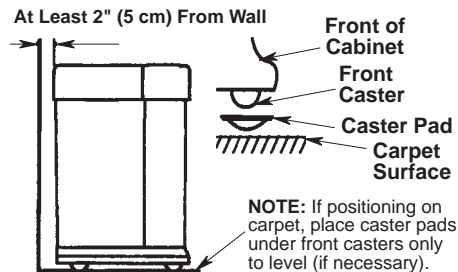

Operating Tips for Best Performance

1. Position the humidifier at least 2 inches (5 cm) from any wall and away from any heat registers.
2. Do not restrict airflow from entering or exiting the humidifier.
3. Use only EPA registered bacteriostat to retard bacteria growth that may cause odors and may be harmful to your health.
4. Perform regular cleaning as instructed in "Cleaning and Maintenance" section of this manual.
5. Replace the evaporative wicking filters at least once per humidification season or more depending on water conditions in your area.

Electrical Hook-Up

Locate nearest 120V A.C. wall socket in the location desired, preferably on inside wall. With the humidifier in the desired location, route the electrical cord safely so no one will trip or upset the humidifier. Plug in the electrical cord.

WARNING: To reduce the risk of fire or shock hazard, humidifier should be plugged into a 120V A.C. outlet. Do not use extension cords.

To reduce the risk of electrical shock, this humidifier has a polarized plug (one blade is wider than the other). This plug will fit in a polarized outlet only one way.

If the plug does not fit fully in the outlet, reverse plug. If it still does not fit, contact a qualified electrician to install the proper outlet. Do not change the plug in any way.

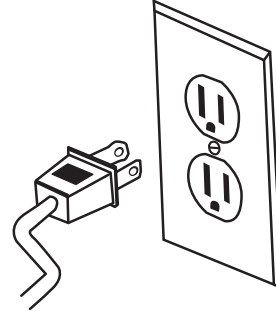

Water Fill

WARNING: To reduce the risk of shock, always unplug humidifier before cleaning or servicing.

WARNING: To reduce the risk of fire or shock hazard, do not pour or spill water into control or motor area. If controls get wet, let them dry completely and have unit checked by authorized service personnel before plugging in.

This humidifier is designed for use with the two water bottles that are located under the pivoting lid.

Open the pivoting lid of the humidifier. Remove the water bottles by lifting them straight up and out of the cabinet.

Notice the water bottles are designed as right and left hand units. Position them in the correct location so the humidifier can function properly. The water bottles should rest in the front of the cabinet. Each "Side-Fill Cap" must be facing the rear of the unit.

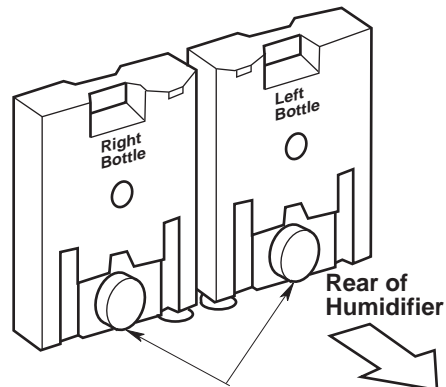
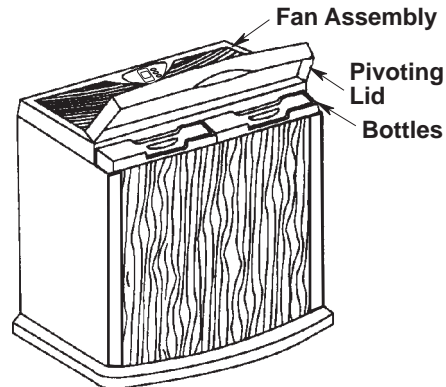

"Side-Fill Cap" Should Always Face Rear

Water Fill (continued)

Each water bottle is designed with a "Side-Fill Cap" that is easily removable. Remove the "Side-Fill Cap" on the side of the water bottle by twisting counterclockwise.

Place the opening of the water bottle under a water faucet (the bottle should fit under a four-inch clearance faucet). Fill with recommended mixture of cold water and Bacteriostat (if necessary) only. Solid debris could make the valve leak.

Install the "Side-Fill Cap" by twisting clockwise. Hand tighten only.

Check for possible leaks by performing the following:

1. Grasp bottle handle and hold the bottle upright over a sink.
2. Press up on the valve cap plunger for about one second to let out a little water.
3. Release the plunger.
4. Listen for air bubbles. Look for leaks around the "Side-Fill Cap".
5. If you hear air bubbles or see leaks, retighten the "Side-Fill Cap" and repeat Steps 1-4.

Wipe off excess water from the bottle.

Position the water bottle back into the unit by grasping the water bottle handle and lower it into the cabinet until the bottle sits on pads at bottom of cabinet. The "Side-Fill Cap" must be facing the rear of the cabinet. When positioned properly, the plunger will open and water will flow into the cabinet. The water level will automatically remain at approximately 1/2" until the bottles are empty.

Allow the filter to saturate for 30 minutes before operation.

Turn Counterclockwise to Remove Cap

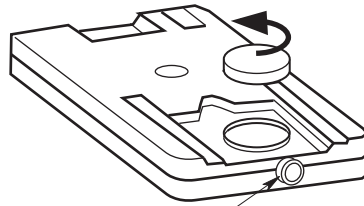

Valve Cap Plunger

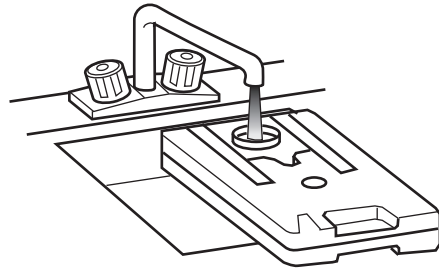

Raised Section

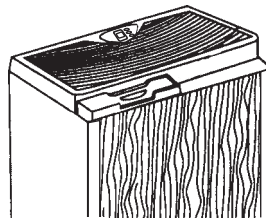

Pivoting Lid Removed for Clarity

Operating the Controls

Where you set your desired humidity levels depends on your personal comfort level, outside temperature and inside temperature. A starting set point of 30% - 40% **ROOM** humidity is recommended but there may be conditions that require a different setting.

IMPORTANT: Water damage may result if condensation starts to form on windows or walls. Humidity **SET** point should be lowered until condensation no longer forms. We recommend room humidity levels do not exceed 50%.

When Outdoor Temperature is:		Recommended Indoor Relative Humidity is:
-10° F	-24° C	20%
2° F	-18° C	25%
10° F	-12° C	30%
20° F*	-6° C*	35%

* and above

To Operate the Controls

Digital Display

Press the power/speed button once to turn the unit on* (⏻). Initially there is a slight delay while the electronics calibrate. Two bars (- -) appear during this time. Once calibration is complete a **ROOM** humidity reading between 20% - 95% will be displayed. A flashing 20 display indicates that the room humidity is less than 20%.

NOTE: The default settings at initial startup are **(Ultra Quiet) F1** fan speed and **65% SET** humidity. After desired settings are selected by the user, they remain as long as the unit remains plugged in and there is no power interruption. If the unit is unplugged the **original** default settings are employed.

* Humidifier fan should operate at initial start up. If it does not, refer to, "Fan not operating (digital display is illuminated)" in the "Trouble Shooting" section on page 14.

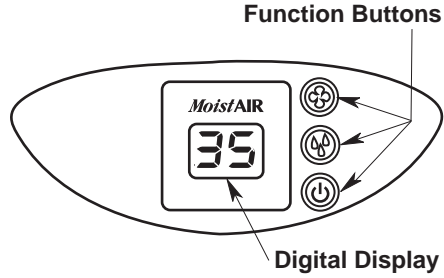

Speed Button (⏻)

This humidifier is equipped with a 3-speed fan control. Initially depressing the speed button will display the current speed setting. Each push of the speed button advances the mode through the settings of **(HIGH) F3**, **(MEDIUM) F2**, and **(Ultra Quiet) F1**.

The selected setting is displayed on the digital readout. The higher the setting, the faster water is evaporated and released into the air. **F1 (Ultra Quiet)** is the quietest setting and is provided for conditions that do not require a rapid evaporation rate.

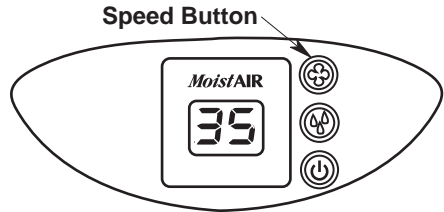

Humidity Control (💧)

This button allows you to adjust the humidity to suit your needs. This humidifier will automatically cycle on and off as required to maintain the selected setting. The readout displays both actual **(ROOM)** and desired **(SET)** humidity percentage (%) settings when humidity control button is pressed. The **ROOM** readout has a range of 20% to 95%. If the room humidity level is equal to or less than 20% the display will show a flashing 20.

Operating the Controls (continued)

The **SET** readout has a range of 25% to 65% and is adjusted in increments of 5%. Initially depressing the humidity button will display the current humidity setting. Each additional press of the button increases the setting by 5%. A **SET** point of 65% operates the humidifier continuously regardless of the **ROOM** reading. The humidistat that senses the readings is located on the power cord. Insure that this humidistat is free from obstruction.

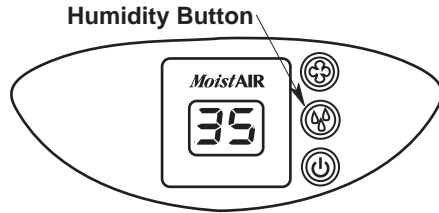

Using Your Humidifier

Refill Display Function

For maximum run time both bottles should be filled. When both bottles are empty the display alternates the room humidity reading and “**F**” (**FILL**), informing additional water is required.

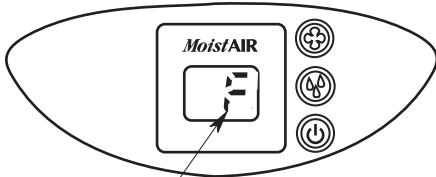

Refill Display

Manual Dry Out

At the end of the humidification season or if you do not plan to run the humidifier for one week or more, a manual dry out mechanism is provided to completely dry out the humidifier cabinet.

To do this, simply slide the float retainer located at the back of the humidifier cabinet to the top position of the slot it is located in. This will hold the float in an upward position and the fan will run until you turn the power off.

NOTE: Be sure to position float retainer to the normal operating mode (lowest position in slot) for normal humidifier operation.

Below is a diagram of the slot the float retainer is located in, at the back of the cabinet.

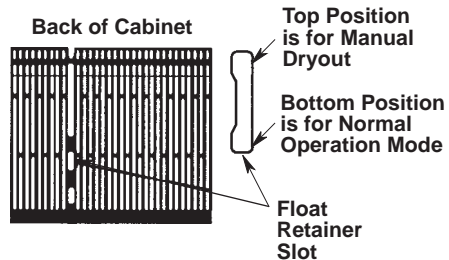

Using Your Humidifier (continued)

Check Filter Indicator

The ability of any humidifier to efficiently supply humidity output relies heavily on the condition of the filter. As the filter loads with impurities it gradually loses its wicking capability. When this happens, moisture output is reduced and the humidifier has to work longer to satisfy the selected setting. This humidifier has a check filter reminder timed to appear after 720 hours of motor operation. When the display shows an alternating “CF” and “room humidity” setting at 5 second intervals it is a reminder to check the filter condition.

NOTE: Some areas have high water mineral content causing the need for more frequent filter changes.

Refer to “Replacement and Care of Filter” on page 11. If a build-up of deposits or severe discoloration is evident replace the filter to restore maximum efficiency.

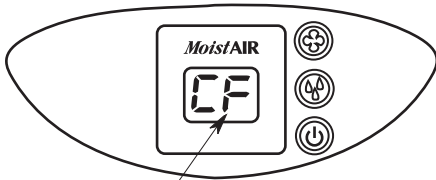

Check Filter Display

Humidistat

The humidistat located on the power cord senses the percentage of humidity in the air. It causes the humidifier to cycle on and off to maintain the selected humidity **SET** point. The fan will turn on if the “**ROOM**” reading falls 3% below the **SET** point and will continue to run the humidifier until a reading of 1% above the **SET** point is achieved. The fan will turn off until the **ROOM** reading falls 3% below the **SET** point again.

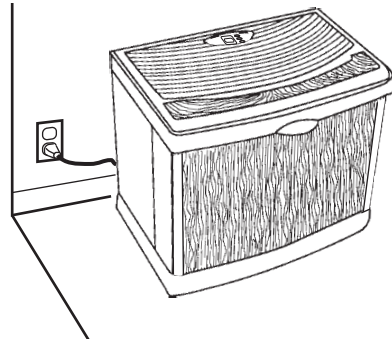

NOTE: Be sure humidistat, which is located on the power cord, is free from obstructions and is away from any hot air source.

Replacement and Care of Filters

WARNING: To reduce the risk of shock or injury from moving parts, always unplug humidifier before removing or replacing any parts.

CAUTION: To help retard bacteria growth and keep maximum efficiency, the filter should be replaced at least once per season, or more often under hard water conditions. Use MoistAIR HDC12 recommended replacement filter.

The filters may be rinsed periodically in clear water only. Take care not to damage paper. To replace evaporative wicking filters in your humidifier, follow these instructions.

1. Unplug humidifier before removing the filters. We recommend moving the humidifier to an area where floor coverings are not susceptible to water damage, i.e. kitchen or bath areas.
2. Open the pivoting lid and remove water bottles and set aside. Grasp the fan assembly front center and rear center. Lift off and set aside on a clean flat surface. The filter housings are now accessible.
3. Lift filter housing out of cabinet and place where you may work on them comfortably. With a soft, absorbent cloth remove any remaining water or loose mineral deposits not trapped in the filter from the humidifier cabinet.
4. To open filter housing for easy access to filters:
 - a. Deflect the two spring tabs on top of filter housing. Lift top cover off of the filter housing and set aside.
 - b. Remove the two filters and dispose of properly. Clean internal parts of humidifier per the "Cleaning and Maintenance" section (page 12) of your operator's manual.

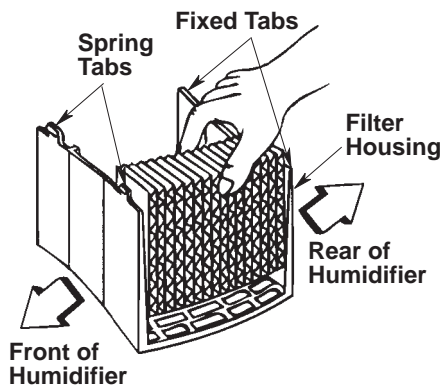
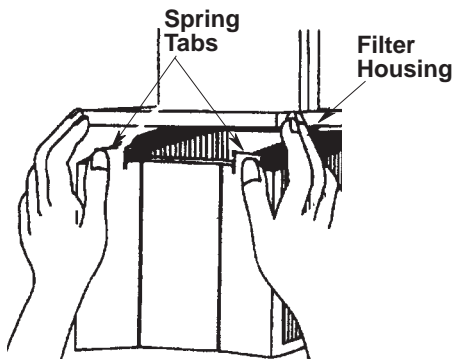
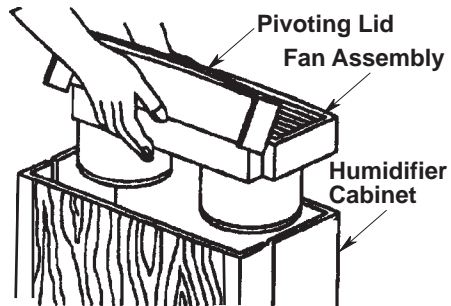

- c. Install new filters in the filter housing track with the glue beads of the wicking pad to the inside of the filter housing.
- d. Return the top cover of the filter housing by installing cover over the fixed tabs on the rear of the lower filter housing and pivoting the cover down over the top of the filters. Snap the cover over the two spring tabs.

Replacement and Care of Filters (cont'd.)

- e. Replace the filter housing in the cabinet.

NOTE: There is a front and back orientation. To position the filter housings correctly:

- Be sure that the spring tabs of filter housings are towards front of cabinet.
 - Align the lower portion of the filter assembly over the six ribs located at the bottom rear of the humidifier cabinet.
- f. Position fan assembly onto the cabinet. Make sure the fan venturi (lowest cylinder section below the fan) is placed inside the filter housing.
- g. Replace water bottles.
- h. Close the pivoting lid.
- i. The unit is ready for use or to be stored away for next season.

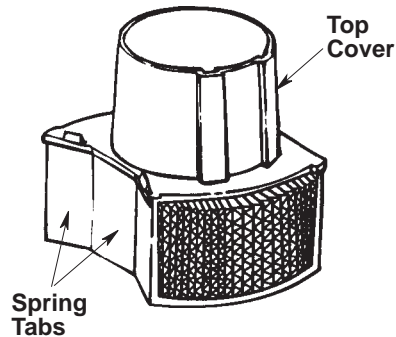

Flat Portion of Filter Housing
Towards Back of Cabinet

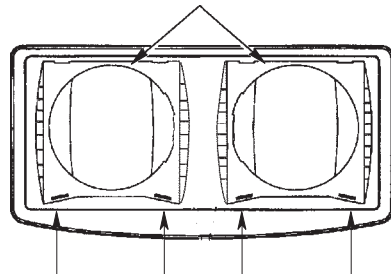

Spring Tabs Towards Front of Cabinet
Step 4e

Cleaning and Maintenance

WARNING: To reduce the risk of injury, fire or damage to humidifier, use only cleaners specifically recommended for humidifiers. Never use flammable, combustible or poisonous materials to clean your humidifier. To reduce the risk of scalds and damage to humidifier, never put hot water in humidifier.

CAUTION: Local water purity varies from area to area and under certain conditions water impurities and airborne bacteria may promote the growth of micro-organisms in the reservoir of the humidifier.

To retard bacteria growth that may cause odors and be harmful to your health, use only MoistAIR replacement filters. We also recommend using EPA approved bacteriostat and humidifier cleaner.

NOTE: If it is necessary to use approved bacteriostat, follow directions correctly. The bottles of the whole house humidifier will hold 2-3/8 gallons/9 litres of water each.

Step 1:

To make cleaning easier, the humidifier cabinet should be empty and completely dried out. To accomplish this, use the following method:

- a. On the back side of the humidifier cabinet, find the float retainer. In normal operating mode, the retainer will be positioned in the bottom of the slot in the cabinet. Push the retainer up to the top slot position in the cabinet until it locks in place. (See "Manual Dryout" section on page 9.)
- b. Allow the humidifier to run until there is no water left in the cabinet.
- c. Unplug humidifier.

Cleaning and Maintenance (cont'd.)

WARNING: To reduce the risk of shock, always unplug humidifier before cleaning or servicing. If humidifier is not unplugged, fan could start after housing is removed.

Step 2:

To Remove Parts

- a. Open the pivoting lid and remove water bottles and set aside. Grasp the fan assembly front center and rear center. Lift off and set aside on a clean flat surface. The filter housings are now accessible.
- b. Before removing the internal parts of the humidifier cabinet, we recommend moving the humidifier to an area where floor covers are not susceptible to water damage, i.e.; kitchen or bath area. Lift the filter housing assemblies out of the cabinet and set to the side.
- c. Remove the water level float from the humidifier cabinet by pinching the float retainer to release it from the cabinet. The cabinet should be empty before cleaning. The cabinet consists of the lower areas of the humidifier where the filters are during normal operation time.
- d. Empty cabinet of any remaining water.
- e. Proceed to "Bi-Weekly Maintenance" or "End of Season Maintenance".
- f. Remove old filters and dispose of properly as described on pages 11-12.

Step 3:

Install new filters (purchase the correct evaporative wicking filter pads HDC12 for your humidifier) into the location where the old filters were positioned. Install the filter housings with the new filters into the correct location. Reinstall the water level float.

NOTE: Float retainer should be positioned in normal operating mode. Assure that it is positioned in the bottom of the slot in the back of the cabinet (See page 9 for diagram of slot).

Position the fan assembly on top of the cabinet and return the humidifier to the desired location for use.

Refill humidifier bottles with fresh cool water and return them to the cabinet. Plug the unit into a 120 volt A.C. power outlet and set the controls per the "Operating Humidifier Controls" section (page 8) of this manual.

Bi-Weekly Maintenance

Removing Scale

1. Fill the reservoir with water and add one 8 oz. (236 ml) cup of undiluted white vinegar. Let solution stay for 20 minutes.
2. Clean all interior surfaces with soft brush. Dampen soft cloth with undiluted white vinegar and wipe out reservoir to remove scale.
3. Rinse thoroughly with clean warm water to remove scale and cleaning solution before disinfecting the reservoir.

Disinfecting Humidifier Cabinet and Water Bottles

1. Fill humidifier cabinet with 1 teaspoon (5 ml) chlorine bleach in 1 gallon (3.8 litres) of water. Let solution stay for 20 minutes, carefully swishing every few minutes. Wet all surfaces normally exposed to water.
2. Empty humidifier cabinet after 20 minutes. Rinse with water until bleach smell is gone. Allow unit to dry out completely.
3. Water bottles should be cleaned in the same manner.

End of Season Maintenance

1. Follow "Bi-Weekly Maintenance" instructions at end of humidification season.
2. Remove and throw away filters.
3. Let humidifier dry completely before storing. Do not store with water inside cabinet or water bottles.
4. Store in cool, dry location.
5. Install a new filters in clean humidifier before next season begins.
6. "Bi-Weekly Maintenance" procedure is also recommended if you do not plan to run the humidifier for one week or more.

Troubleshooting

Trouble	Probable Cause	Remedy
Digital display not illuminated.	<ul style="list-style-type: none"> No Power. Power button has not been depressed. 	<ul style="list-style-type: none"> Check 120 volt power source. Press power button once to turn on.
Fan not operating (digital display is illuminated).	<ul style="list-style-type: none"> ROOM humidity level is not 3% or more below SET humidity level. Reservoir is empty. 	<ul style="list-style-type: none"> Raise SET humidity level if desired. Increase fan speed. Fill humidifier with water.
Fan running continuously, unit will not shut off.	<ul style="list-style-type: none"> Float is obstructed. SET humidity level is 65%. ROOM humidity level has not reached 1% or more above SET humidity level. 	<ul style="list-style-type: none"> Free float from obstruction. A SET humidity percentage of 65% operates fan continuously. Adjust SET level between 25% - 60%. Continue to run until desired humidity level is achieved. This may take up to 48 hours initially.
Poor evaporation of water.	<ul style="list-style-type: none"> Check filter message "CF" is flashing. Mineral buildup on filter. 	<ul style="list-style-type: none"> Change to a fresh new filter. NOTE: Local water purity varies from area to area.
Neither bottle emptying.	<ul style="list-style-type: none"> Bottle cap plunger missing post in bottom of cabinet. Dirty filters. 	<ul style="list-style-type: none"> Check orientation of bottles. Reposition so that bottle cap plunger (stem) is depressed by post in bottom of cabinet. Change to fresh new filters (HDC12).
Bottles continues to empty.	<ul style="list-style-type: none"> Air is entering water bottle. 	<ul style="list-style-type: none"> Check "Side-Fill Caps" and valve assembly caps to ensure tightness. Check for leak in water bottle. Ensure gaskets for "Side-Fill Caps" are in place.
Left bottle not emptying.	<ul style="list-style-type: none"> Right bottle contains water. 	<ul style="list-style-type: none"> The humidifier is designed so that right bottle empties first.
Refill display "F" is on before bottles are empty.	<ul style="list-style-type: none"> Unit is not set up on a level surface. (Float will not sense water at the front of the cabinet.) 	<ul style="list-style-type: none"> Position unit level. (Some carpet padding may allow unit to sit lower in the front than rear with the additional weight of water bottles in the front of the cabinet. Install caster pads under front casters (see page 5).
Display blinks or fan moves slightly when humidifier is plugged in.	<ul style="list-style-type: none"> Normal. 	<ul style="list-style-type: none"> No action required.
Alternating "F" and room humidity displayed.	<ul style="list-style-type: none"> Reservoir is empty. 	<ul style="list-style-type: none"> Fill humidifier with water.
Alternating "CF" and room humidity displayed.	<ul style="list-style-type: none"> Filter may be dirty. 	<ul style="list-style-type: none"> Replace filter.

CAUTION: Use only EPA Registered Bacteriostat.

Use of other water treatment products may damage the filter elements. Under no circumstances should you use water treatment products designed for Roto belt or Ultrasonic humidifiers.

Repair Parts

Parts List for MoistAIR® Humidifier Model No. HD14070

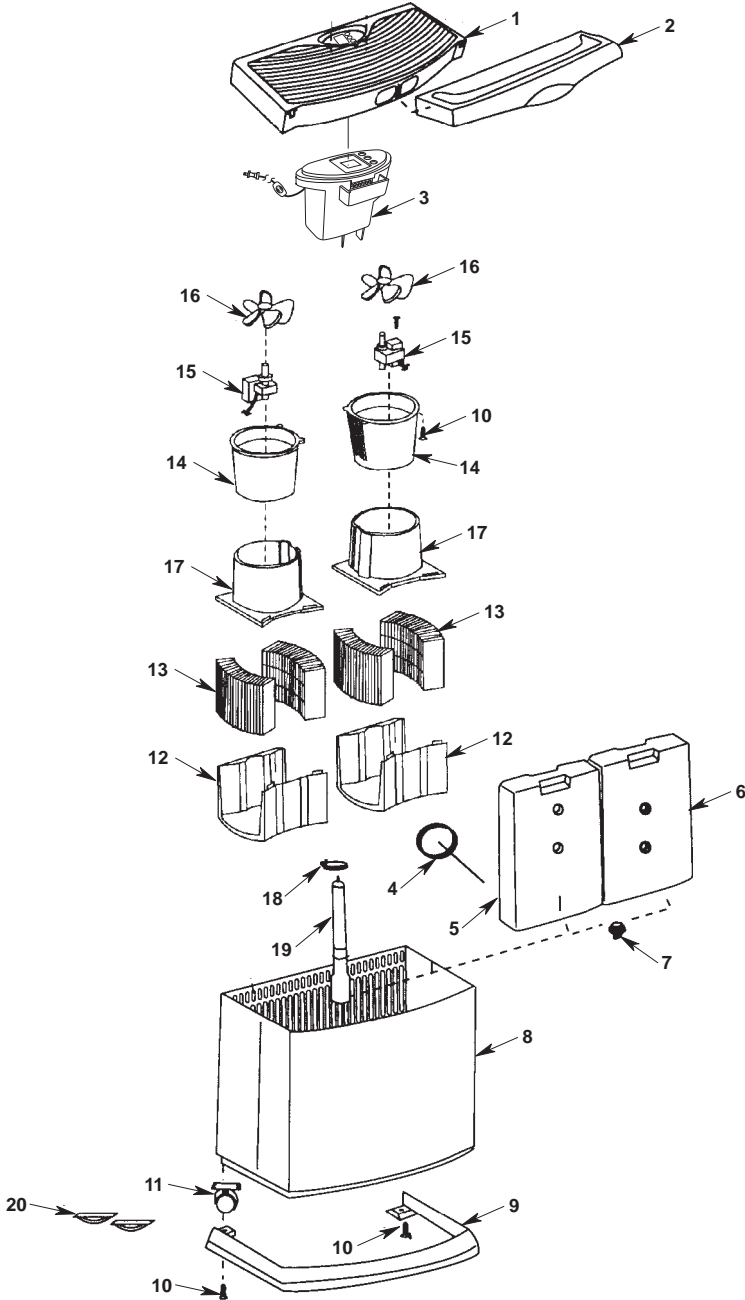

Repair Parts

Parts List for MoistAIR® Humidifier Model No. HD14070

Always order by part number - Not by key number

Key No	Part No.	Description
1	828741-2	Lid, Stationary
2	828855-2	Lid, Pivoting
3	831680-1	Control Assembly
4	824690	"Side-Fill Cap"
5	828192	Bottle, Left (Includes Key Nos. 4 & 7)
6	828726	Bottle, Right (Includes Key Nos. 4 & 7)
7	509229-1	Cap, Valve Assembly
8	828199-10	Cabinet
9	823726	Rail, Kick
10	STD601107	*Screw, Pan Hd. Ty "AB" #10 x 3/4
11	828515	Caster, Twin Wheel
12	830560-1	Support, Filter Lower
13	HDC12	†Filter, Evaporative
14	828534	Support, Motor
15	828115-1	Motor
16	822406-1	Fan
17	828197	Support, Upper Filter
18	824101	Retainer, Float
19	828200-3	Float, Water Level
20	828920	Pad, Caster (Two)
—	SP6647	Operator's Manual (not illustrated)

NOTE: Any attempt to repair the control assembly or motor may create a hazard unless repair is done by a qualified service technician.

* Standard Hardware Item - May be purchased locally

† Stock item - Purchase locally or call 1-800-654-3545 from USA or 1-866-808-6500 from Canada to order.

To order parts call: USA:1-800-654-3545
Canada: 1-866-808-6500

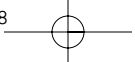

FOR TECHNICAL HELP, CALL
(800) 654-3545 FROM USA OR (888) 744-4687 FROM CANADA
(Please have complete model number)

MoistAIR[®]



Emerson Tool Company

For more information about MoistAIR[®] humidifiers, visit our website at
www.moistair.com

