



HEATING & COOLING

INDUCED-COMBUSTION

58PAV & 58RAV

# GAS FURNACE

**⚠ WARNING:** If the information in this manual is not followed exactly, a fire or explosion may result causing property damage, personal injury or loss of life.

- Do not store or use gasoline or other flammable vapors and liquids in the vicinity of this or any other appliance.
- **WHAT TO DO IF YOU SMELL GAS:**
  - Do not try to light any appliance.
  - Do not touch any electrical switch; do not use any phone in your building.
  - Immediately call your gas supplier from a neighbor's phone. Follow the gas supplier's instructions.
  - If you cannot reach your gas supplier, call the fire department.
- Installation and service must be performed by a qualified installer, service agency or the gas supplier.

**Do not use this furnace if any part has been under water. Immediately call a qualified service technician to inspect the furnace and to replace any part of the control system and gas control which has been under water.**

**USER'S INFORMATION MANUAL FOR  
THE OPERATION AND MAINTENANCE  
OF YOUR NEW GAS-FIRED FURNACE**

**NOTE TO INSTALLER:  
THIS MANUAL MUST BE LEFT WITH THE  
EQUIPMENT USER.**

# WELCOME TO TODAY'S GENERATION OF COMFORT

Congratulations! Your new, high-efficiency gas furnace is a sound investment which will reward you and your family with years of warm memories winter after winter.

Not only is your new furnace energy efficient, it is also extremely reliable. Spend just a few minutes with this booklet to learn about the operation of your new furnace—and the small amount of maintenance it takes to keep it operating at peak efficiency. Years went into the development of your new furnace. Take a little time now to assure its most efficient operation for years to come.

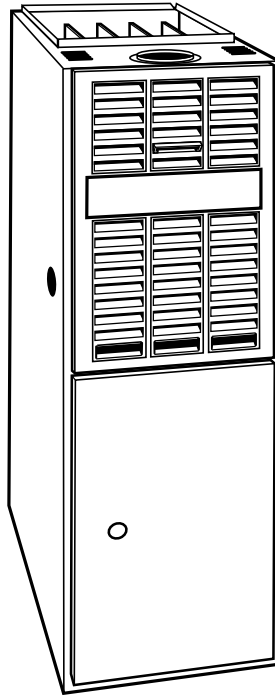

1

**MODEL 58PAV  
UPFLOW FURNACE**

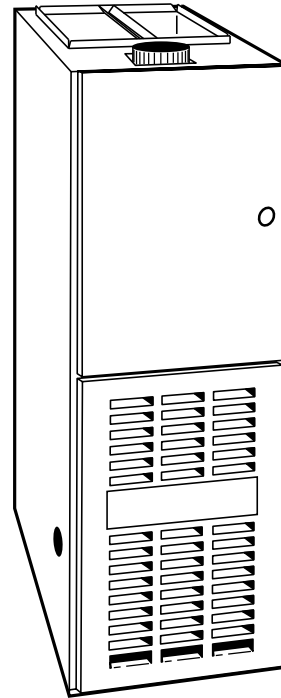

2

**MODEL 58RAV  
DOWNFLOW/  
HORIZONTAL FURNACE**

## UPFLOW FURNACE COMPONENTS

- 1 Relief Box
- 2 Rating Plate
- 3 Gas Valve Control Knob or Electric Switch (On/Off)
- 4 Gas Valve
- 5 Manual Reset Limit Switch
- 6 Gas Burner
- 7 Flame Sensor
- 8 Hot Surface Ignitor
- 9 Status LED Light
- 10 Blower and Blower Motor
- 11 Draft Safeguard Tube and Switch
- 12 Gas Manifold
- 13 Blower Door Safety Switch
- 14 Filter Retainer
- 15 Air Filter

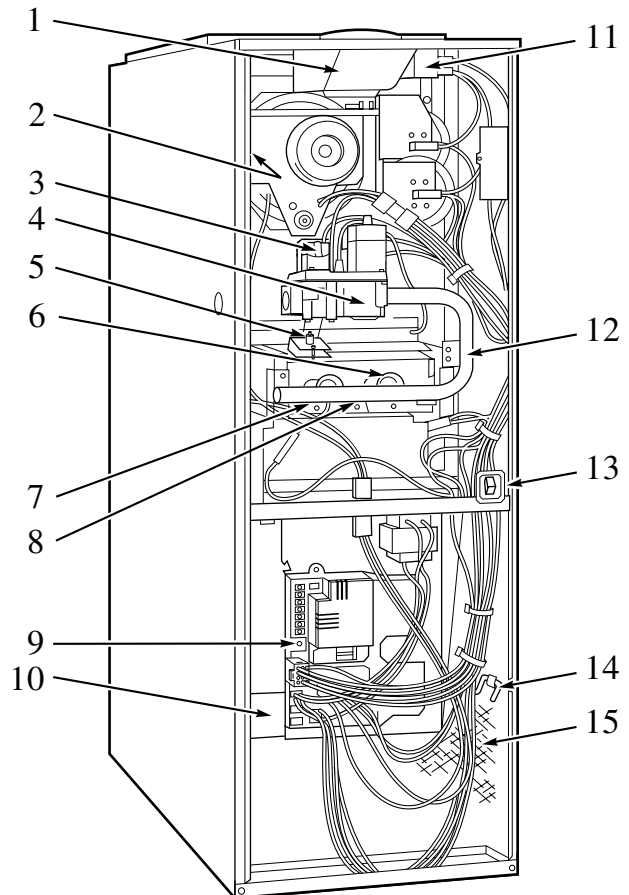

3

## DOWNFLOW/HORIZONTAL FURNACE COMPONENTS

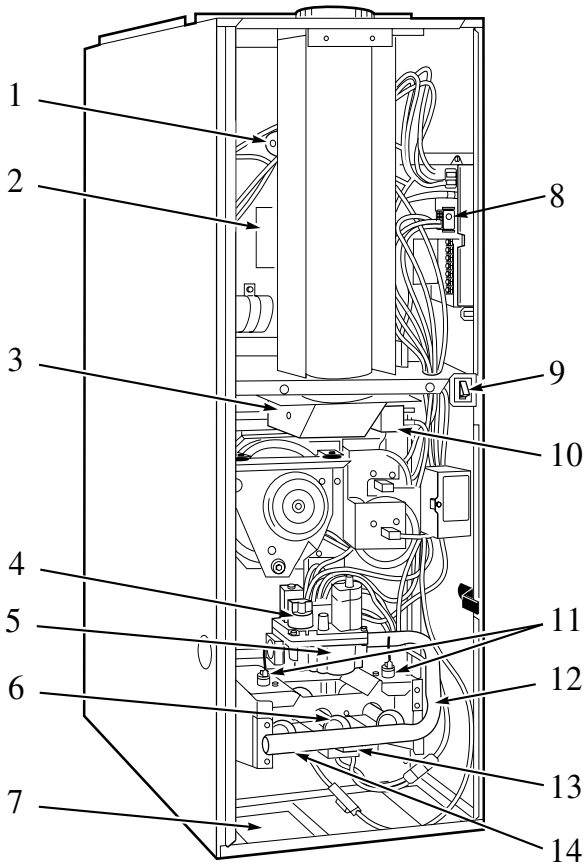

- 1 Manual Reset Auxiliary Limit Switch (When Used)
- 2 Blower and Blower Motor
- 3 Relief Box
- 4 Gas Valve Control Knob or Electric Switch (On/Off)
- 5 Gas Valve
- 6 Gas Burner
- 7 Rating Plate
- 8 Draft Safeguard Tube and Switch
- 9 Gas Manifold
- 10 Hot Surface Ignitor
- 11 Manual Reset Limit Switch (2)
- 12 Flame Sensor
- 13 Status LED Light
- 14 Blower Door Safety Switch

4

### IMPORTANT FACTS

Your furnace must have adequate airflow for efficient combustion and safe ventilation. Do not enclose it in an airtight room or “seal” it behind solid doors.

To minimize the possibility of serious personal injury, fire, furnace damage, or improper operation, **carefully follow these safety rules:**

- Keep the area around your furnace free of combustible materials, gasoline, and other flammable liquids and vapors.

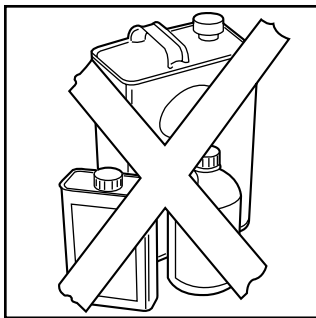

- Do not cover the furnace, store trash or debris near it, or in any way block the flow of fresh air to the unit.
- Combustion air must be clean and uncontaminated with chlorine or fluorine. These compounds are present in many products around the home, such as: water softener

salts, laundry bleaches, detergents, adhesives, paints, varnishes, paint strippers, waxes, and plastics.

Make sure the combustion air for your furnace does not contain any of these compounds. During remodeling be sure the combustion air is fresh and uncontaminated. If these compounds are burned in your furnace, the heat exchangers and metal vent system may deteriorate.

- A furnace installed in an attic or other insulated space must be kept free and clear of insulating material. Examine the furnace area when installing the furnace or adding more insulation. Some materials may be combustible.

**NOTE:** Do not use this furnace if any part has been under water. Immediately call a qualified service technician to inspect the furnace and to replace any part of the control system and any gas control which has been under water.

**NOTE:** The qualified installer or agency must use only factory-authorized replacement parts, kits, and accessories when modifying this product.

This furnace contains safety devices which must be manually reset. If the furnace is left unattended for an extended period of time, have it checked periodically for proper operation. This precaution will prevent problems associated with no heat, such as frozen water pipes, etc. See “Before You Request a Service Call” section in this manual.

5

### SAFETY CONSIDERATIONS

Installing and servicing heating equipment can be hazardous due to gas and electrical components. Only trained and qualified personnel should install, repair, or service heating equipment.

3

Untrained personnel can perform basic maintenance functions such as cleaning and replacing air filters. All other operations must be performed by trained service personnel. Observe safety precautions in this manual, on tags, and on labels attached to the furnace and other safety precautions that may apply.

Recognize safety information. This is the safety-alert symbol . When you see this symbol on the furnace and in instructions or manuals, be alert to the potential for personal injury.

Understand the signal words—DANGER, WARNING, and CAUTION. These words are used with the safety-alert symbol. DANGER identifies the most serious hazards which **will** result in severe personal injury or death. WARNING signifies hazards which **could** result in personal injury or death. CAUTION is used to identify unsafe practices which **would** result in minor personal injury or product and property damage.

## STARTING YOUR FURNACE

Instead of a continuously burning pilot flame, your furnace uses an automatic hot surface ignition system to light the burners each time the thermostat signals the furnace to start. **Follow these important safeguards:**

- Never attempt to manually light the burners with a match or other source of flame.

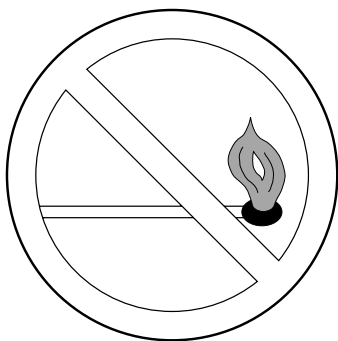

6

- Read and follow the operating instructions on the furnace, especially the item that reads as follows:

Wait 5 minutes to clear out any gas. Then smell for gas, including near the floor. If you smell gas, **STOP!** Follow “B” in the safety information above on this label. If you don’t smell gas, go to the next step.

- If a suspected malfunction occurs with your gas control system, such as the burners do not light when they should, refer to the shutdown procedures on the furnace, or in the next section, to turn off your system, then call your dealer as soon as possible.

### WARNING

**Should overheating occur or the gas valves fail to shut off the gas supply, turn off the manual gas valve (See Fig. 8.) to the furnace BEFORE turning off the electrical supply. A failure to follow this warning could result in a fire or explosion, and personal injury or death.**

- **Check Air Filter:** Before attempting to start your furnace, be sure the furnace filter is clean and in place. (See the maintenance section of this manual.) Then proceed as follows:

## STEPS FOR STARTING YOUR FURNACE

1. Set your room thermostat to the lowest temperature setting. (See Fig. 7.)
2. Close the external manual gas valve. (See Fig. 8.)

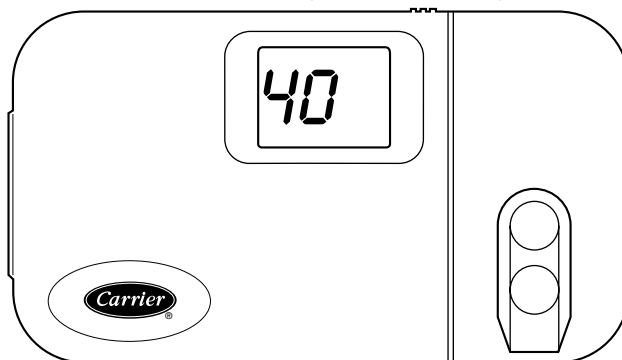

7

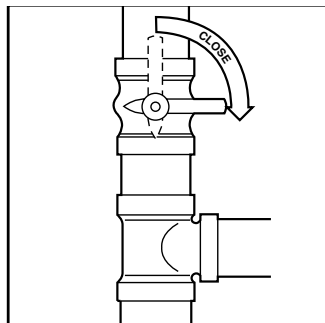

8

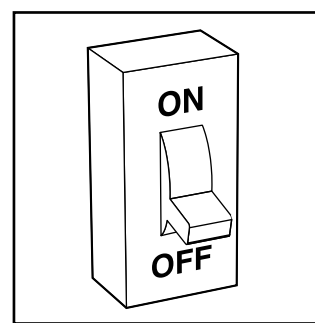

9

3. Turn OFF electrical supply to the furnace. (See Fig. 9.)
4. Remove the furnace access door(s).
  - a. Downflow/Horizontal—Remove blower door after removing 2 screws first, then remove the control door. (See Fig. 10.)
  - b. Upflow—Remove control door. (See Fig. 11.)

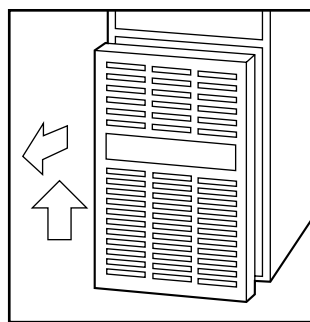

10

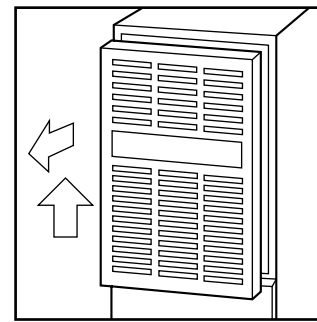

11

5. The gas valve will have EITHER a control knob or control switch to turn off and on. Turn the control knob or switch on the gas valve to the OFF position and wait 5 minutes. (See Fig. 12 or 13.)
6. After waiting 5 minutes, turn the control knob or switch on the gas valve to the ON position. (See Fig. 14 or 15.)
7. Replace the access door(s). See Fig. 16 for upflow and Fig. 17 for downflow. Replace control door first on downflow furnaces. Replace blower door and secure with 2 screws.
8. Turn ON the electrical supply to the furnace. (See Fig. 18.)

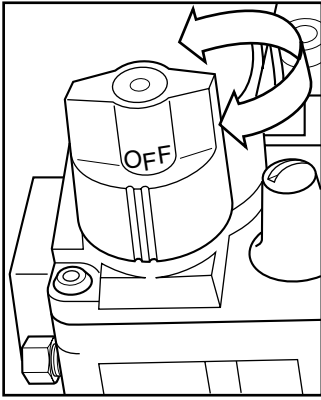

12

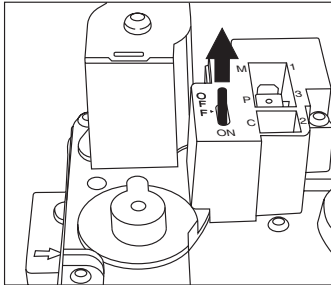

OR

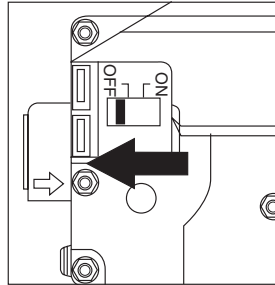

13

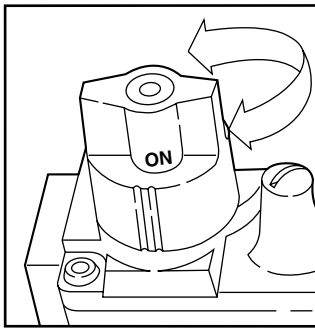

14

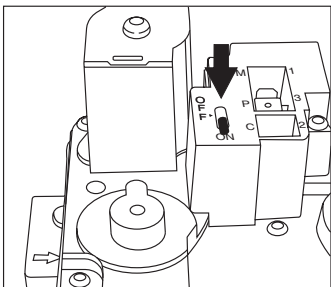

OR

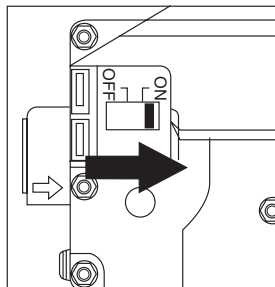

15

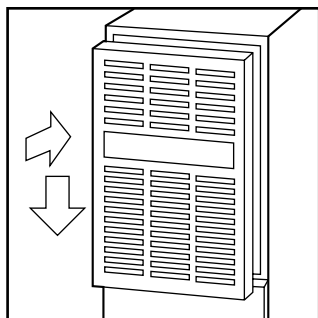

16

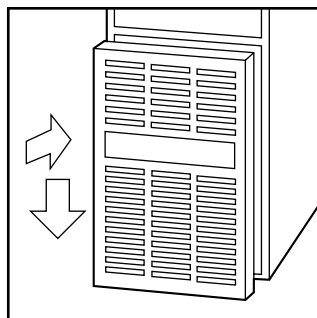

17

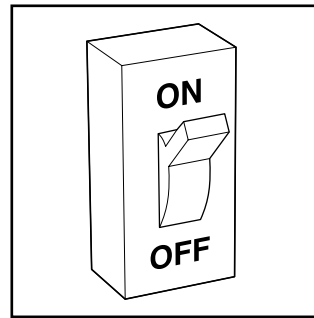

18

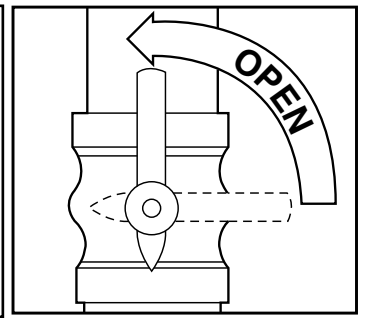

19

9. Open the external manual gas valve. (See Fig. 19.)
10. Set the room thermostat to a temperature slightly above the room temperature. This will automatically signal the furnace to start. The inducer motor will start, and the hot surface ignitor will energize. When hot, the ignitor will have an orange glow.
11. After 15 to 70 sec, the gas valve permits gas to flow to the main burners where it is ignited. Hot flames begin to warm the furnace's heat exchanger. After a time delay of approximately 45 sec, the furnace blower is switched on.

**NOTE:** If the main burners fail to ignite, the furnace control system will go through 3 more ignition cycles. Then, if burners still fail to ignite, the system will lockout. If lockout occurs, or the blower does not come on—shut down your furnace and call your dealer for service.

12. Set your thermostat to the temperature that satisfies your comfort requirements. **SUGGESTION:** Setting the thermostat back a few degrees—and compensating for the difference with warmer clothing—can make a big difference in your fuel consumption on extremely cold days. The few degrees at the top of your thermostat “comfort level” are the most costly degrees to obtain.

When the room temperature drops below the temperature selected on the thermostat, the furnace will be switched on automatically. When the room temperature reaches the setting selected on the thermostat, the furnace will be automatically switched off.

Some thermostats have a “FAN” mode with 2 selections, AUTO and ON. When thermostat is set on AUTO, the furnace blower cycles on and off, controlled by the thermostat. In ON position, the furnace blower runs continuously except for a 45-sec delay at the “call for heat.” This keeps the temperature level in your home more evenly balanced.

It also continuously filters the indoor air.

## SHUTTING DOWN YOUR FURNACE

Should you ever suspect a malfunction in your furnace, you will need to turn the furnace off. The following procedures must be followed:

1. Set your room thermostat to the lowest temperature setting. (See Fig. 20.)
2. Close the external manual gas valve (See Fig. 8 on page 4.)
3. Turn OFF electrical power to your furnace. (See Fig. 21.)

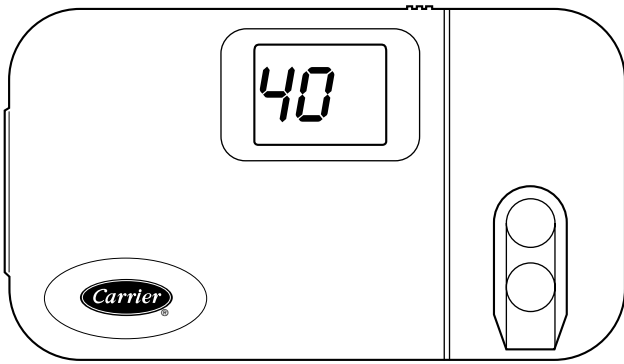

20

**⚠ CAUTION**  
 Although special care has been taken to minimize sharp edges, be extremely careful when handling parts or reaching into the furnace.

**FILTERING OUT TROUBLE**

A dirty filter will cause excessive stress on the furnace blower motor and can cause it to overheat and automatically shut down. The furnace filter should be checked every 3 or 4 weeks and cleaned if necessary.

If installed with factory specified disposable media filter, check or replace filter before each heating and cooling season. Replace disposable media filter at least once a year.

If your furnace filter needs replacing, be sure to use the same size and type of filter that was originally supplied. Use the Furnace Filter Table and compare your furnace size with the proper filter size.

**⚠ CAUTION**  
 Never operate your furnace without a filter in place. Doing so may damage the furnace blower motor. An accumulation of dust and lint on internal parts of your furnace can cause a loss of efficiency.

The air filter for upflow furnaces is normally located in the blower compartment. Filters for the downflow furnaces are normally located in the return-air plenum above the blower. If air filter has been installed in another location, contact your dealer for instructions. To inspect, clean and/or replace the air filter(s), follow these steps:

• **Upflow Furnaces Only—**

1. Turn OFF the electrical supply to the furnace. (See Fig. 21.)
2. Remove control and blower access doors.

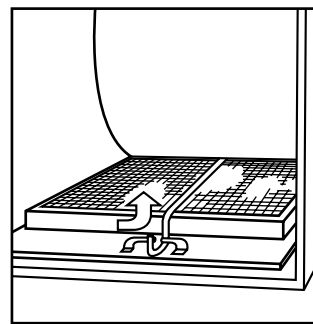

24

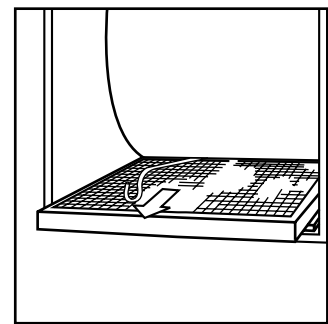

25

3. Push filter retainer toward the bracket opening to release the filter. (See Fig. 24.)
4. Gently remove the filter and carefully turn the dirty side up (if dirty) to avoid “spilling” dirt from the filter. (See Fig. 25.)

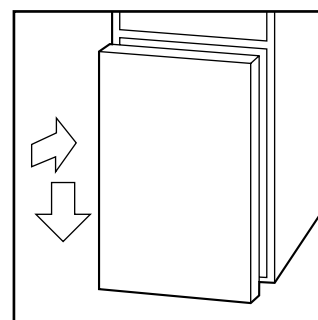

26

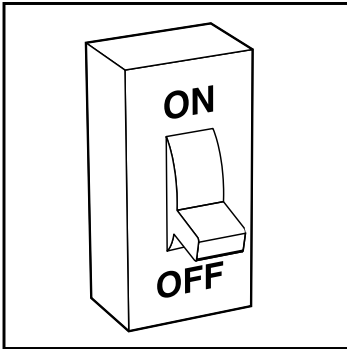

21

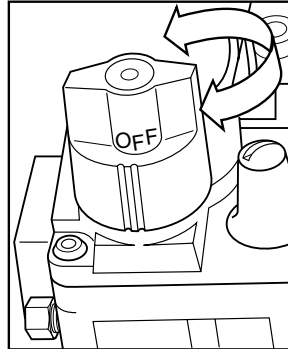

22

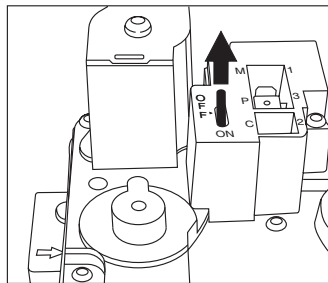

OR

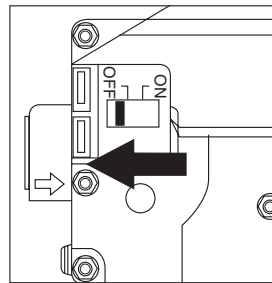

23

4. Remove the control access door on your furnace. (See Fig. 10 or 11.) On upflow furnaces, removing the blower access door is not required.
5. Turn the control knob or switch on the gas valve to the OFF position. (See Fig. 22 or 23.)
6. Replace the control access door. (See Fig. 16 or 17.)
7. If the furnace is being shut down because of a malfunction, call your dealer as soon as possible.

**PERFORMING ROUTINE MAINTENANCE**

With proper maintenance and care, your furnace will operate economically and dependably. Basic maintenance, which can easily be accomplished by someone who follows the directions, is found on this and the following pages. However, before beginning maintenance, follow these safety precautions:

**⚠ WARNING**  
 Turn off electrical power supply to your furnace before removing the access doors to service or perform maintenance. A failure to follow this warning could result in personal injury or death.

5. Inspect the filter. If torn, replace the filter.
6. Wash the filter (if dirty) in sink, bathtub, or outside with a garden hose. Always use cold tap water. A mild liquid detergent may be used if necessary. Spray water through the filter in the opposite direction of airflow. Allow filter to dry.
7. Reinstall the clean filter.
8. Put filter retainer back in the bracket opening and lock it in place.
9. Replace blower and control access doors and turn ON electrical power to your furnace. (See Fig. 16, 17, and 26.)

**NOTE:** For upflow models only—if side return ducts are used, 2 filters may be required in some models. The procedure listed above may be used to remove side filters.

• **Downflow/Horizontal Furnaces Only:**

Two filters are located in the return-air plenum above the blower (above line-of-sight) resting in the V-shaped channel on top of the furnace. (See Fig. 27.)

1. Turn OFF electrical supply to the furnace. (See Fig. 21.)
2. Remove 2 screws from blower access door and remove the door.
3. Remove the left-side filter by tipping the filter toward the center and raising it from the V-shaped channel in which it rests. (See Fig. 27 and 28.)
4. Lower filter down along side of the blower and remove from the furnace.
5. To remove the right-side filter, lift from V-shaped channel and remove through left side the same way as left-side filter.
6. Inspect the filter. If torn, replace the filter.
7. Wash the filter (if dirty) in a sink, bathtub, or outside with a garden hose. Always use cold tap water. A mild liquid detergent may be used if necessary. Spray water through the filter in opposite direction of airflow. Allow filter to dry.
8. Reinstall the clean filters.

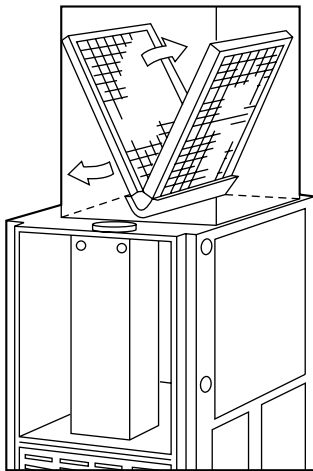

27

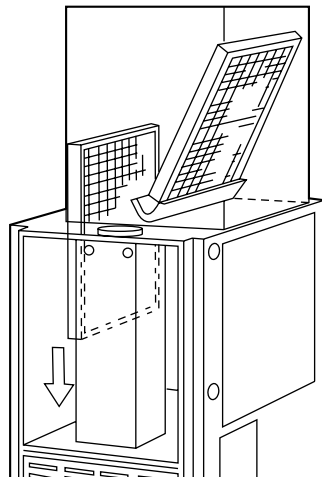

28

9. Replace blower door and secure with 2 screws. Turn on electrical power to your furnace.

**UPFLOW FURNACE FILTER TABLE**

FURNACE CASING WIDTH (IN.)	FILTER SIZE (IN)		FILTER TYPE
	Side Return	Bottom Return	
14-3/16	(1) 16 x 25 x 1*	(1) 14 x 25 x 1	Cleanable
17-1/2	(1) 16 x 25 x 1*	(1) 16 x 25 x 1	Cleanable
21	(1) 16 x 25 x 1	(1) 20 x 25 x 1*	Cleanable
24-1/2	(1 or 2) 16 x 25 x 1	(1) 24 x 25 x 1*	Cleanable

**DOWNFLOW/HORIZONTAL FURNACE FILTER TABLE**

FILTER CASING WIDTH	FILTER SIZE (IN)	FILTER TYPE
14-3/16	(2) 16 x 20 x 1*	Cleanable
17-1/2	(2) 16 x 20 x 1*	Cleanable
21	(2) 16 x 20 x 1*	Cleanable
24-1/2	(2) 16 x 20 x 1*	Cleanable

\* Factory provided with the furnace. Filters may be field modified by cutting to size. Alternate sizes and additional filters may be ordered from your dealer.

**⚠ CAUTION**

**Use care when cutting support rods in filters to protect against flying pieces and sharp rod ends. Wear safety glasses, gloves, and appropriate protective clothing. Failure to follow this caution could result in personal injury.**

**COMBUSTION AREA AND VENT SYSTEM**

Inspect the combustion area and vent system before each heating season. An accumulation of dirt, soot, or rust can mean a loss of efficiency and improper performance. Build-ups on the main burners can cause faulty firing. This “delayed ignition” is characterized by an alarmingly loud sound. If your furnace makes a loud noise when the main burners are ignited, shut down the furnace and call your servicing dealer. Use your flashlight and follow these steps for inspecting the combustion area and vent system of your furnace:

1. Turn off electrical supply to the furnace and remove the access doors. (See Fig. 9, and 10 or 11.)
2. Carefully inspect the gas burner for dirt, rust, or scale (see Fig. 29). Inspect the relief box, flue connection area, and the vent pipe for rust.

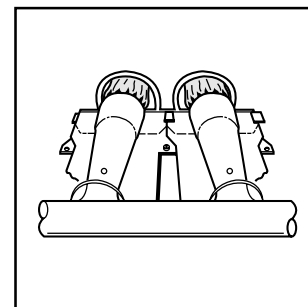

**NOTE:** If dirt, rust, soot, or scale accumulations are found, call your servicing dealer. **DO NOT OPERATE THE FURNACE.**

## **▲ WARNING**

**If holes are found—or if the vent pipe is obstructed or is not connected—toxic fumes can escape into your home. DO NOT OPERATE YOUR FURNACE. Call your dealer for service. A failure to follow this warning could result in personal injury or death.**

3. Inspect the vent pipe for a sag, holes, or a disconnection. A horizontal vent pipe must slope upward. If rusty joints or seams, or signs of water leakages are found, call your dealer for service.
4. Replace the access doors and restore electrical power to the furnace. Be sure bottom door flange is inside of the furnace casing. (See Fig. 16, 17 and 26.)
5. Start the furnace and observe its operation. If possible, watch the burner flames. Are they burning bright blue? If not (or if you suspect some other malfunction), call your servicing dealer.

## **BEFORE YOU REQUEST A “SERVICE CALL”**

### **Before you call for service, check for several easily solved problems:**

- Check for sufficient airflow. Check the air filter for dirt. Check for blocked return-air or supply-air grilles. Be sure they are open and unobstructed. If this isn't the cause of the problem, call your servicing dealer.

If your furnace isn't operating at all, check the following list for easily solved problems:

- Is your thermostat set above room temperature? Is the HEAT mode selected?
- Is the electrical power supply switch on? Is the blower access door firmly in place? Are any fuses blown? (There is a fuse on the furnace control.) Has a circuit breaker tripped?
- Is the manual shut-off valve in the gas supply pipe leading to the furnace open? Does the lever point in the same direction that the pipe runs (open)? Or is it at a right angle to the pipe (closed)?

**NOTE:** Before proceeding with the next checks, turn off the electrical power supply to the furnace. Remove access doors.

- Is the control knob or switch on the gas valve turned to the ON position? If this or the preceding check shows an interruption in the gas supply, make sure the gas has not been shut off for safety reasons. If nothing else seems to be wrong, follow the startup procedures found on pages 4 and 5 of this booklet.
- If for some reason the vent is blocked, the draft safeguard switch will shut off the furnace. Reset the switch by pushing the button located on top of the switch. See page 2 or 3 for switch location.

If the switch trips a second time, turn off the furnace and call for service.

- **Downflow/Horizontal Only**—Check the manual reset auxiliary limit switch (when used) located on the blower housing. If the blower motor fails, this switch will shut off the furnace. Reset it by pushing the button on the switch. If it trips again, turn off the furnace and call for service.

- Check the manual reset flame rollout switch(es) located near the burners. If the furnace has experienced a high-temperature condition due to inadequate combustion air, these switches will shut off the furnace. Reset the switch(es) by pushing the button on the switch. If the switch trips a second time, turn off the furnace and call for service.

- If your furnace still fails to operate, call your servicing dealer for troubleshooting and repairs. Tell your dealer the model and serial numbers for your furnace. (You should have them recorded on page 8 of this booklet.) By knowing exactly which furnace you have, the dealer may be able to offer suggestions over the phone or save valuable time through knowledgeable preparation for the service call.

### **Regular dealer maintenance**

In addition to the type of routine maintenance you might be willing to do, your furnace should be inspected regularly by a properly trained service technician. An annual inspection (or biennial inspection, at least) should include the following:

1. Inspection of all flue product passages—including the burners, heat exchanger, relief box, and vent pipe.
2. Inspection of all combustion and ventilation air passages and openings.
3. Close check of all gas pipes leading to (and inside of) your furnace.
4. Inspection, cleaning, and lubrication (when required) of the blower motor and wheel.

**NOTE:** Refer to the unit Service Procedures for blower motor oiling information. When required, the motor must be oiled by a qualified service technician.

5. Routine inspection and cleaning/replacement of the air filter.
6. Inspection of all supply- and return-air ducts for obstructions, air leaks, and insulation. Any problems found should be resolved at this time.
7. Inspection of furnace installation for proper support and any obvious deterioration of the furnace. The support must be sound and without sags, gaps, cracks, etc., around the furnace base so as to provide an air seal between the support and furnace.
8. A check for loose connections attaching individual components. Inspection of all electrical wiring and their connections.
9. Operational check of the furnace itself to determine working condition. Repair or adjustment should be made at this time.

Ask your servicing dealer for further details about an economical service contract that covers seasonal inspections.









## INSTALLATION DATA

Date Installed \_\_\_\_\_

Dealer Name \_\_\_\_\_

Address \_\_\_\_\_

City \_\_\_\_\_

State \_\_\_\_\_ Zip \_\_\_\_\_

Telephone \_\_\_\_\_

### FURNACE

Product No. \_\_\_\_\_

Model No. \_\_\_\_\_

Serial No. \_\_\_\_\_

### SPLIT-SYSTEM

#### OUTDOOR UNIT

Product No. \_\_\_\_\_

Model No. \_\_\_\_\_

Serial No. \_\_\_\_\_

#### INDOOR COIL:

Product No. \_\_\_\_\_

Model No. \_\_\_\_\_

Serial No. \_\_\_\_\_



**Carrier**

A United Technologies Company

TO OBTAIN INFORMATION ON PARTS: Consult your installing dealer or the classified section of your local telephone directory under the "Heating Equipment" or "Air Conditioning Contractors & Systems" heading for dealer listing by brand name. Have available the Model No., Series Letter, & Serial No. of your equipment to ensure correct replacement part.

**Carrier Corporation 7310 West Morris St. Indianapolis, IN 46231**

Manufacturer reserves the right to discontinue, or change at any time, specifications or designs without notice and without incurring obligations.