



Website: <http://www.lgservice.com>

# MICROWAVE OVEN

## OWNER'S MANUAL & COOKING GUIDE

PLEASE READ THIS OWNER'S MANUAL THOROUGHLY BEFORE OPERATING.

### LRMM1430SW/LRMM1430SB

# TABLE OF CONTENTS

<p><b>SAFETY</b> ..... 3-5</p> <p>Precautions to Avoid Possible Exposure to Excessive Microwave Energy ..... 3</p> <p>Grounding Instructions ..... 3</p> <p>Important Safety Instructions ..... 4-5</p> <p><b>UNDERSTANDING YOUR MICROWAVE OVEN</b> 6-10</p> <p>Specifications ..... 6</p> <p>Installation ..... 6</p> <p>Parts and Accessories ..... 7</p> <p>Control Panel ..... 7</p> <p>Cookware Guide ..... 8</p> <p>Tips for Microwave Cooking ..... 9</p> <p>Precautions ..... 10</p> <p>Cleaning ..... 10</p> <p><b>USING YOUR MICROWAVE OVEN</b> ..... 11-22</p> <p>Clock ..... 11</p> <p>Kitchen Timer ..... 11</p> <p>Child Lock ..... 11</p> <p>Ez-ON ..... 11</p> <p>More/Less ..... 12</p> <p>Sensor Cook Operation Instruction ..... 12</p> <p>Potato ..... 12</p> <p>Reheat ..... 12</p> <p>Sensor Cook Table ..... 13</p> <p>Homemade Bakery ..... 14</p>	<p>Homemade Bakery Table ..... 14</p> <p>Chicken Choices ..... 14</p> <p>Chicken Choices Table ..... 14</p> <p>Children's Lunch ..... 15</p> <p>Children's Lunch Table ..... 15</p> <p>Fast Breakfast ..... 15</p> <p>Fast Breakfast Table ..... 15</p> <p>Soften ..... 16</p> <p>Soften Table ..... 16</p> <p>Melt ..... 16</p> <p>Melt Table ..... 16</p> <p>Timed Cooking ..... 17</p> <p>2 Stage Timed Cooking ..... 17</p> <p>Auto Defrost ..... 18</p> <p>Q- Defrost ..... 18</p> <p>Auto Defrost Table ..... 19-20</p> <p><b>HEATING/REHEATING GUIDE</b> ..... 21</p> <p><b>FRESH VEGETABLE GUIDE</b> ..... 22</p> <p><b>TROUBLESHOOTING</b> ..... 23-25</p> <p>Questions and Answers ..... 23-24</p> <p>Before Calling for Service ..... 25</p> <p><b>WARRANTY</b> ..... <b>Inside back cover</b></p>
--	---

## *Thank you for purchasing a LG microwave oven.*

Please record the model number and serial number of this unit for future reference. We also suggest you record the details of your contact with LG (LG Electronics U.S.A., Inc.) concerning this unit.

Model No: \_\_\_\_\_  
 Serial No: \_\_\_\_\_  
 Dealer: \_\_\_\_\_  
 \_\_\_\_\_  
 Dealer Phone No: \_\_\_\_\_

Staple your receipt here for proof of purchase.

Customer Relations  
 LG Electronics U.S.A., Inc.  
 Service Division Bldg. #3  
 201 James Record Rd.  
 Huntsville, AL 35824-0126

# SAFETY

## PRECAUTIONS TO AVOID POSSIBLE EXPOSURE TO EXCESSIVE MICROWAVE ENERGY

- **Do not attempt to operate this oven with the door open**, since open-door operation can result in harmful exposure to microwave energy. It is important not to defeat or tamper with the safety interlocks.
- **Do not place any object between the oven front face and the door**, or allow soil or cleaner residue to accumulate on sealing surfaces.
- **Do not operate the oven if it is damaged.** It is particularly important that the oven door closes properly and that there is no damage to the:
  - door (bent),
  - hinges and latches (broken or loosened),
  - door seals and sealing surfaces.
- **The oven should not be adjusted or repaired** by anyone except properly qualified service personnel.

## GROUNDING INSTRUCTIONS

This appliance must be grounded. In the event of an electrical short circuit, grounding reduces the risk of electric shock by providing an escape wire for the electric current. This appliance is equipped with a cord having a grounding wire and a grounding plug. The plug must be plugged into an outlet that is properly installed and grounded.

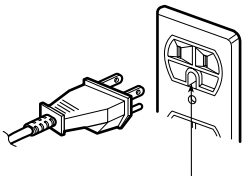

Ensure proper ground exists before use

### **⚠ WARNING ⚠**

Improper grounding can result in a risk of electric shock. Consult a qualified electrician if the grounding instructions are not completely understood, or if doubt exists as to whether the appliance is properly grounded, and either:

1. If it is necessary to use an extension cord, use only a 3-wire extension cord that has a 3-blade grounding plug and a 3-slot receptacle that will accept the plug on the appliance.

The marked rating of the extension cord shall be equal to or greater than the electrical rating of the appliance, or . . .

2. Do not use an extension cord. If the power supply cord is too short, have a qualified electrician or serviceman install an outlet near the appliance.

#### NOTES:

1. A short power-supply cord is provided to reduce the risks resulting from becoming entangled in or tripping over a longer cord.
2. Longer cord sets or extension cords are available and may be used if care is exercised in their use.
3. If a long cord or extension cord is used, (1) the marked electrical rating of the cord set or extension cord should be at least as great as the electrical rating of the appliance, (2) the extension cord must be a grounding-type 3-wire cord, and (3) the longer cord should be arranged so that it will not drape over the countertop or tabletop where it can be pulled on by children or tripped over accidentally.

# SAFETY

## IMPORTANT SAFETY INSTRUCTIONS

The safety instructions below will tell you how to use your oven to avoid harm to yourself or damage to your oven.

**WARNING** - To reduce the risk of burns, electric shock, fire, injury to persons, or exposure to excessive microwave energy:

1. Read all instructions before using the appliance.
2. Read and follow the specific **PRECAUTIONS TO AVOID POSSIBLE EXPOSURE TO EXCESSIVE MICROWAVE ENERGY** found on page 3 of this manual.
3. This appliance must be grounded. Connect only to properly grounded outlet. See **GROUNDING INSTRUCTIONS** found on page 3 of this manual.
4. Install or locate this appliance only in accordance with the provided installation instructions.
5. Some products, such as whole eggs and sealed containers – for example, closed glass jars are able to explode and should not be heated in this oven.
6. Use this appliance only for its intended use as described in the manual. Do not use corrosive chemicals or vapors in this appliance. This type of oven is specifically designed to heat, cook, or dry food. It is not designed for industrial or laboratory use.
7. As with any appliance, close supervision is necessary when used by children.
8. Do not operate this appliance if it has a damaged cord or plug, if it is not working properly, or if it has been damaged or dropped.
9. This appliance should be serviced only by qualified service personnel. Contact the nearest authorized service facility for examination, repair, or adjustment.
10. Do not cover or block any openings on the appliance.
11. Do not store this appliance outdoors. Do not use this product near water – for example, near a kitchen sink, in a wet basement, near a swimming pool, or similar location.
12. Do not immerse cord or plug in water.
13. Keep cord away from heated surfaces.
14. Do not let cord hang over the edge of a table or counter.
15. When cleaning surfaces of door and oven that come together on closing the door, use only mild, nonabrasive soaps or detergents applied with a sponge or soft cloth.
16. To reduce the risk of fire in the oven cavity:
  - a. Do not over cook food. Carefully attend appliance when paper, plastic, or other combustible materials are placed inside the oven to facilitate cooking.
  - b. Remove wire twist-ties from paper or plastic bags before placing bag in oven.
  - c. If materials inside the oven ignite, **KEEP OVEN DOOR CLOSED**, turn oven off, and disconnect the power cord or shut off power at the fuse or circuit breaker panel.
  - d. Do not use the cavity for storage purposes. Do not leave paper products, cooking utensils, or food in the cavity when not in use.
17. Liquids, such as water, coffee, or tea are able to be overheated beyond the boiling point without appearing to be boiling. Visible bubbling or boiling when the container is removed from the microwave oven is not always present. **THIS COULD RESULT IN VERY HOT LIQUIDS SUDDENLY BOILING OVER WHEN THE CONTAINER IS DISTURBED OR A SPOON OR OTHER UTENSIL IS INSERTED INTO THE LIQUID.** To reduce the risk of injury to persons;
  - 1) Do not overheat the liquid.
  - 2) Stir the liquid both before and halfway through heating it.
  - 3) Do not use straight-sided containers with narrow necks.
  - 4) After heating, allow the container to stand in the microwave oven for a short time before removing the container.
  - 5) Use extreme care when inserting a spoon or other utensil into the container.
18. Avoid heating small-necked containers such as syrup bottles.
19. Avoid using corrosive and vapors, such as sulfide and chloride.
20. Liquids heated in certain shaped containers (especially cylindrical-shaped containers) may become overheated. The liquid may splash out with a loud noise during or after heating or when adding ingredients (instant coffee, etc.), resulting in harm to the oven and possible injury. In all containers, for best results, stir the liquid several times before heating. Always stir liquid several times between reheatings.

## SAVE THESE INSTRUCTIONS

# SAFETY

This section discusses the concepts behind microwave cooking. It also shows you the basics you need to know to operate your microwave oven. Please read this information before you use your oven.

## HOW YOUR MICROWAVE WITH SMART WAVE TECHNOLOGY WORKS

A microwave oven uses microwaves to heat food. Microwaves are very short waves of electromagnetic energy that travel at the speed of light (186,282 miles per second). Microwaves used in microwave ovens are in the same family of frequencies as the signals used in radio and television broadcasting.

In the case of microwave ovens, the commonly used wave frequency is roughly 2,450 megahertz (2.45 gigahertz). Waves in this frequency range have an interesting property: they are absorbed by water, fats and sugars. When they are absorbed they are converted directly into atomic motion-heat. Microwaves in this frequency range have another interesting property: they are not absorbed by most plastics, glass or ceramics. Metal reflects microwaves, which is why metal pans do not work well in a microwave oven.

One of the most important components used in the microwave oven is the Magnetron. A magnetron, in the microwave oven is responsible for the production of microwaves. These microwaves produced by the magnetron, move into the oven and come in contact with the food placed on the glass turntable. Further, the glass turntable inside the oven lets the microwaves pass through. These microwaves further bounce off a metal floor and travel back through the glass turn table and are finally absorbed by the food, placed inside the oven .

One of the characteristic features of microwaves is that they can pass through most glass, papers and plastics without heating them and they further get absorbed by the food in the form of heat energy. The microwaves bounce off the metal container and so the metal container does not absorb its energy.

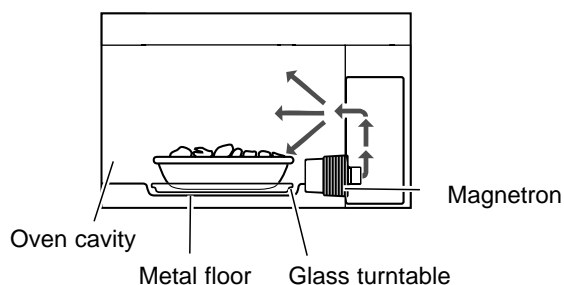

### SMART WAVE™ INVERTER MICROWAVE SYSTEM

SMART WAVE™ Inverter Microwave System gives you better microwave cooking performance for defrosting, cooking and reheating foods quickly and uniformly. The SMART WAVE™ Inverter Microwave System is proven technology that delivers a constant stream of microwave power - true high, medium and low power.

Conventional microwave ovens operate on HIGH power only. To achieve 70% power level in a conventional microwave oven, the oven operates 70% of the time at HIGH power and 70% of the time OFF.

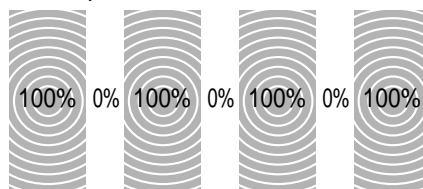

The SMART WAVE™ Inverter Microwave System delivers power continuously, to defrost more evenly and minimize overcooking of food and messy food spatters.



### SENSOR COOKING

The SMART WAVE™ Inverter Microwave System features Sensor Cooking functions. A humidity sensor in the oven cavity detects moisture and humidity emitted from food as it gets heated.

The sensor adjusts cooking time according to various types and amounts of food. Sensor cooking takes the guesswork out of microwave cooking.

### FOR THE BEST COOKING RESULTS

- Keep a check on the cooking of food.
- In order to make sure that the food is evenly cooked, stir, turn, or rearrange the food around halfway during the cooking time.
- Plastic wrap 1/4 to 1/2 inches ( 6.35 to 12.7 mm), in order to vent steam during heating or cooking.

# UNDERSTANDING YOUR MICROWAVE OVEN

## SPECIFICATIONS

Power Supply	120 V AC, 60 Hz
Rated Power Consumption	1,250 W
Microwave Output	*1,200 W
Rated Current	11 A
Overall Dimensions (WxHxD)	20 <sup>3</sup> / <sub>4</sub> " x 15 <sup>1</sup> / <sub>4</sub> " x 19 <sup>1</sup> / <sub>4</sub> "
Oven Cavity Dimensions (WxHxD)	17 <sup>1</sup> / <sub>4</sub> " x 9" x 16 <sup>3</sup> / <sub>4</sub> "
Capacity of Oven Cavity	1.4 Cu. Ft.

\*IEC 60705 RATING STANDARD

Specifications subject to change without prior notice.

## INSTALLATION

1. Remove your microwave oven and all packing materials from the shipping carton.
  2. Place the oven on a level surface that provides at least 4 inches of space at the left, right, top, and rear sides for proper ventilation.
  3. Place the turntable roller rest in the circle on the oven floor and then place the glass turntable on the top of the turntable roller rest.
- NOTE:** Never place the glass turntable in the oven upside down. Blocking the inlet and/or outlet openings can damage the oven.

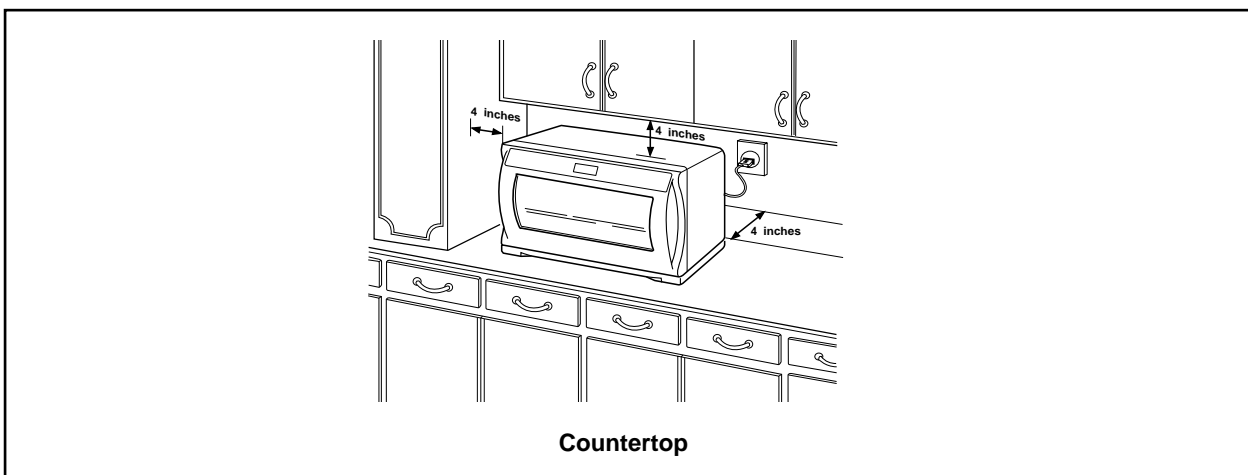

### **WARNING**

To reduce the risk of fire or electric shock, do not install closer than 4 inches to side and back wall.

# UNDERSTANDING YOUR MICROWAVE OVEN

## PARTS AND ACCESSORIES

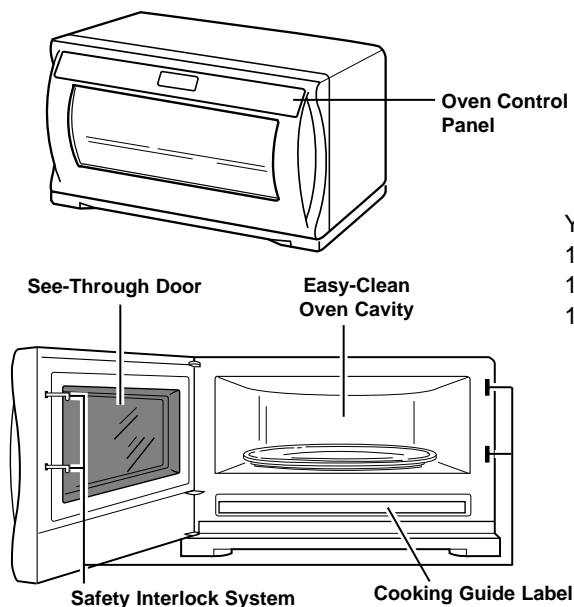

Your oven comes with the following accessories:

- 1 Owner's Manual & Cooking Guide
- 1 Glass Turntable
- 1 Turntable Roller Rest

Glass Turntable

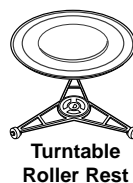

## CONTROL PANEL

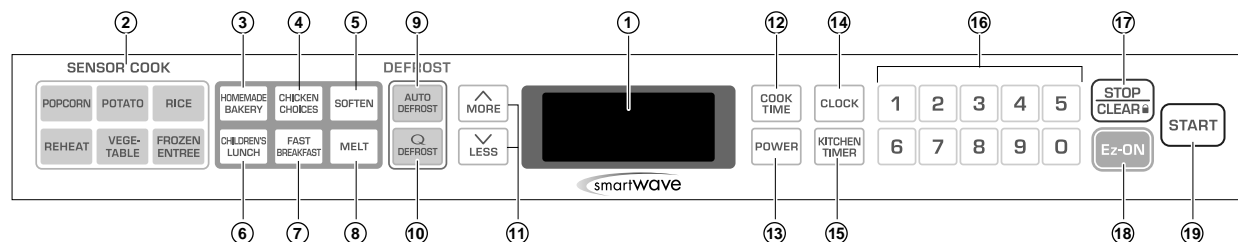

- 1. Display.** The Display includes a clock and indicators that tell you time of day, cooking time settings, and cooking functions selected.
- 2. Sensor Cook.** This pad allows you to cook most of your favorite foods without having to select cooking times and power levels.
- 3. Homemade Bakery.** Homemade bakery has 3 food categories of preset cooking time and power level.
- 4. Chicken Choices.** Chicken Choices has 4 food categories of preset cooking time and power level.
- 5. Soften.** Touch this pad to soften ice cream, cream cheese, butter or frozen juice.
- 6. Children's Lunch.** Children's Lunch has 3 food categories of preset cooking time and power level.
- 7. Fast Breakfast.** Fast Breakfast has 3 food categories of preset cooking time and power level.
- 8. Melt.** Touch this pad to melt chocolate, cheese, butter or marshmallows.
- 9. Auto Defrost.** This pad is an accurate defrosting method for meat, poultry, fish and bread.
- 10. Q-Defrost.** Touch this pad to defrost foods quickly.
- 11. More / Less.** Touch these pads to adjust cooking time in 10 second increments.
- 12. Cook time.** Touch this pad to set a cooking time.
- 13. Power.** Touch this pad to set a cooking power.
- 14. Clock.** Touch this pad to enter the time of day.
- 15. Kitchen Timer.** Touch this pad to use your microwave oven as a kitchen timer.
- 16. Number pads.** Touch Number pads to enter cooking time, Power level, quantities, or weights.
- 17. Stop/Clear.** Touch this pad to stop the oven or clear entries. Also used to turn Child Lock on and off.
- 18. Ez-ON.** You can extend cooking time in multiples of 30 seconds by repeatedly touching this pad during cooking.
- 19. Start.** Touch this pad to start the oven.

# UNDERSTANDING YOUR MICROWAVE OVEN

## COOKWARE GUIDE

Most heat-resistant, non-metallic cookware is safe for use in your microwave oven. However, to test cookware before using, follow these steps:

1. Place the empty cookware in the microwave oven.
2. Measure 1 cup of water in a glass measuring cup and place it in the oven beside the cookware.
3. Microwave on 100% power for 1 minute. If the dish is warm, it **should not** be used for microwave cooking.

USE	DO NOT USE
<p><b>Ovenproof Glass</b></p> <ul style="list-style-type: none"> <li>• Glass treated for use in high-intensity heat includes utility dishes, bread dishes, pie plates, cake plates, liquid measuring cups, casseroles, and bowls without metallic trim.</li> </ul> <p><b>China</b></p> <ul style="list-style-type: none"> <li>• Bowls, cups, serving plates, and platters without metallic trim can be used in your oven.</li> </ul> <p><b>Plastic</b></p> <ul style="list-style-type: none"> <li>• When using plastic wrap as a cover, make sure that the dish is deep enough so the plastic wrap does not touch the food. As the food heats, it may melt the plastic wrap wherever the wrap touches the food.</li> <li>• Place plastic wrap loosely over the top of the dish and secure it by pressing the wrap to the sides of the dish.</li> <li>• Vent by turning back one corner of the plastic wrap. This will allow excess steam to escape.</li> <li>• Use plastic dishes, cups, semi-rigid freezer containers, and plastic bags <b>only for short time cooking. Use these with care because the plastic may soften from the heat of the food.</b></li> </ul> <p><b>Paper</b></p> <ul style="list-style-type: none"> <li>• Microwave-safe paper towels, waxed paper, paper napkins, and paper plates with no metallic trim or design can be used in your oven.</li> <li>• Refer to the manufacturer's label for use of any paper product in the microwave oven.</li> </ul>	<p><b>Metal Utensil</b></p> <ul style="list-style-type: none"> <li>• Metal shields food from microwave energy and produces uneven cooking. Avoid metal skewers, thermometers, or foil trays.</li> <li>• Metal utensils can cause arcing, which is a discharge of electric current. Arcing can damage your microwave oven.</li> </ul> <p><b>Metal Decoration</b></p> <ul style="list-style-type: none"> <li>• Do not use metal-trimmed or metal-banded dinnerware, casserole dishes, etc.</li> </ul> <p><b>Centura™ Tableware</b></p> <ul style="list-style-type: none"> <li>• The Corning Company recommends that you <b>do not use</b> Centura tableware and some Corelle™ closed-handle cups for microwave cooking.</li> </ul> <p><b>Aluminum Foil</b></p> <ul style="list-style-type: none"> <li>• Avoid large sheets of aluminum foil because they hinder cooking and may cause arcing.</li> <li>• Use small pieces of foil to shield poultry legs and wings.</li> <li>• Keep <b>all</b> aluminum foil at least 1 inch from the walls and door of the oven.</li> </ul> <p><b>Wood</b></p> <ul style="list-style-type: none"> <li>• Wooden bowls, boards, and baskets will dry out and may split or crack when you use them in the microwave oven.</li> </ul> <p><b>Tightly Closed Containers</b></p> <ul style="list-style-type: none"> <li>• Tightly closed cookware can explode. Be sure to leave an opening for steam to escape from covered cookware.</li> </ul> <p><b>Brown Paper</b></p> <ul style="list-style-type: none"> <li>• Avoid using brown paper bags. They absorb heat and could burn.</li> </ul> <p><b>Metal Twist Ties</b></p> <ul style="list-style-type: none"> <li>• Always remove metal twist ties as they can become hot and cause a fire.</li> </ul>



# UNDERSTANDING YOUR MICROWAVE OVEN

## TIPS FOR MICROWAVE COOKING

### BROWNING

Meat and poultry with high fat content cooked for at least 10 to 15 minutes will brown lightly. Foods cooked a shorter time can be brushed with a browning agent, such as Worcestershire sauce, soy sauce, or barbecue sauce.

### COVERING

A cover will trap heat and steam and cause the food to cook more quickly. Use a lid or microwave-safe plastic wrap with one corner folded back to vent the excess steam. Lids on glass casseroles can become hot during cooking; always handle carefully. Waxed paper will prevent the food from splattering in the oven and help retain heat. When warming bread items, use waxed paper, napkins, or paper towels. To absorb extra moisture, wrap sandwiches and fatty foods in paper towels.

### SPACING

Arrange individual foods, such as baked potatoes, cupcakes, and hors d'oeuvres in a circle and at least 1 inch apart. This will help the food cook more evenly.

### STIRRING

Stirring blends flavors and redistributes the heat in foods. Always stir from the outside toward the center of the dish. Food at the outside of the dish heats first.

### TURNING

Large foods, such as roasts and whole poultry, should be turned so that the top and bottom cook evenly. Also turn over chicken pieces and chops.

### ARRANGEMENT

Do not stack food. Arrange in a single layer in the dish for more even cooking. Because dense foods cook more slowly, place thicker portions of meat, poultry, fish, and vegetables toward the outside of the dish.

### TESTING FOR DONENESS

Foods cook quickly in a microwave oven; test frequently for doneness.

### STANDING TIME

Food often needs to stand from 2 to 15 minutes after being removed from the oven. Usually, you need to cover food during standing time to retain heat. Remove most foods when they are slightly undercooked and they will finish cooking during standing time. The internal temperature of food will rise about 10°F during standing time.

### SHIELDING

To prevent some portions of rectangular or square dishes from overcooking, you may need to shield them with small strips of aluminum foil to block the microwaves. You can also cover poultry legs and wing tips with foil to keep them from overcooking. **Always keep foil at least 1 inch from oven walls** to prevent arcing.

### PIERCING

Pierce the shell, skin, or membrane of foods before cooking to prevent them from bursting. Foods that require piercing include yolks and whites of eggs, hot dogs, clams, oysters, and whole vegetables, such as potatoes and squash.

# UNDERSTANDING YOUR MICROWAVE OVEN

## PRECAUTIONS

- Place the front surface of the door three inches or more from the countertop edge to avoid accidental tipping of the microwave oven during normal use.
- To program the oven, make sure you touch the center of each pad firmly since the areas between the pads will not activate the oven. A tone will sound each time a pad is touched correctly. Do not touch several pads at once.
- Do not strike the control panel with silverware, cookware, etc. Breakage may occur.
- Always use caution when taking cookware out of the oven. Some dishes absorb heat from the cooked food and may be hot. See the "Cookware Guide" earlier in this section for more information.
- Do not rinse cookware immediately after cooking. This may cause breakage. Also, always allow the turntable to cool before removing it from the oven.
- Never operate the oven when it is empty. Food or water should always be in the oven during operation to absorb the microwave energy.
- Do not use the oven to dry newspapers or clothes. They may catch fire.
- Use thermometers that have been approved for microwave oven cooking.
- The turntable must always be in place when you operate the oven.
- Do not use your microwave oven to cook eggs in the shell. Pressure can build up inside the shell, causing it to burst.
- There are several precautions to follow when microwaving popcorn:
  - Do not pop popcorn, except in a microwave-safe container or commercial packages designed for microwave ovens.
  - Never try to pop popcorn in a paper bag that is not microwave-approved.
  - Overcooking may result in smoke and fire.
  - Do not repop unpopped kernels.
  - Do not reuse popcorn bags.
  - Listen while corn pops. Stop oven when popping slows to 2-3 seconds between pops.
  - Do not leave microwave unattended while popping corn.
  - Follow directions on bag.

## CLEANING

**NOTE:** Before cleaning the oven, unplug the power cord. If this is impossible, open the oven door to prevent an accidental oven start.

### INTERIOR

Wipe the oven inside and outside with a soft cloth and a mild detergent solution. Then rinse and wipe dry. This should be done weekly or more often, if needed. Never use cleaning powders or rough pads.

Excessive oil splatters on the inside top will be difficult to remove if left for many days. Wipe splatters with a wet paper towel, especially after cooking chicken or bacon.

### REMOVABLE PARTS

The turntable and rotating ring are removable. They should be hand-washed in warm (not hot) water with a mild detergent and a soft cloth. Once they are clean, rinse well and dry with a soft cloth. Never use cleaning powders, steel wool, or rough pads.

- The turntable may be cleaned at the sink. Be careful not to chip or scratch the edges as this may cause the turntable to break during use.
- The rotating ring should be cleaned regularly.

### DOOR









For best performance and safety, the inner door panel and the oven front frame should be free of food or grease buildup. Wipe often with a mild detergent; then rinse and wipe dry. Never use cleaning powders or rough pads.

After cleaning the control panel, touch STOP/CLEAR to clear any entries that might have been entered accidentally while cleaning the panel. Also make sure that the turntable and rotating ring are in the right position.

# USING YOUR MICROWAVE OVEN

## CLOCK

**Example: To set the clock for 10:30(AM).**

- | Touch:   | Display Shows:                   |
|--|----------------------------------|
| 1.    | :                                |
| 2.    | : ENTER TIME OF DAY              |
| 3.     | 10 : 30 TOUCH START              |
| 4.    | 10 : 30 AM TOUCH 1<br>PM TOUCH 2 |
| 5.    | AM 10 : 30 TOUCH<br>START        |
| 6.    | AM 10 : 30                       |

## KITCHEN TIMER

Your microwave oven can be used as a kitchen timer. You can set up to 99 minutes, 99 seconds.



**Example: To set 3 minutes.**

- | Touch:   | Display Shows:                      |
|--|-------------------------------------|
| 1.    | : ENTER TIME IN MIN<br>AND SEC      |
| 2.    | 3 : 00 TOUCH START                  |
| 3.    | 3 : 00 TIMER<br><br>(Starts timer.) |

## CHILD LOCK

Use this safety feature to lock the control panel when you are cleaning the oven, or so that children cannot use the oven unsupervised.

**To set CHILD LOCK:**

- | Touch:   | Display Shows:  |
|--|---|
| 1.  | Time of day.  |
| 2.  | Touch and hold until LOCKED appears in the display. (approximately 4 seconds) <b>LOCKED</b> |



**To cancel CHILD LOCK:**

- | Touch:  | Display Shows:  |
|---|---|
| 1.  | Touch and hold until LOCKED disappears from the display. (approximately 4 seconds) Time of day. |

## Ez-ON

A time-saving pad, this simplified control lets you quickly set and start microwave cooking at 100% power without the need to touch START.

**Example: To cook for 1 minutes.**

- | Touch:   | Display Shows:                            |
|--|---|
| 1.        | Time of day.                              |
| 2.  Twice | 1 : 00 POWER 100<br><br>(Starts cooking.) |

**NOTE:**

If you touch **Ez-ON**, it will add 30 seconds up to 3 minutes 30 seconds; after 3 minutes 30 seconds, every touch will add 1 minute up to 99 min 59 seconds.





# USING YOUR MICROWAVE OVEN

## MORE / LESS

By using the more or less key, all of the **Soften**, **Melt**, **Time Cook**, **Sensor Cook** programs can be adjusted to cook food for a longer or shorter period of time. Pressing the more key will add 10 seconds to the cooking time each time the key is used. Pressing the less key will subtract 10 seconds of cooking time each time the key is used. However, you can adjust the cook time only after the cook time is displayed during Sensor cooking.

**Example: To adjust the cooking time.**

**Touch:** **Display Shows:**

1.  Time of day.  
1:00
2.  TOUCH START OR POWER
3.  1:00  
POWER 100
4.  Remaining time will be increased by 10 seconds.

**NOTE:**

 Remaining time will be decreased by 10 seconds.



- Opening the door or touching the STOP/CLEAR pad before the vapor is detected will abort the process and the oven will stop.
- Before using Sensor Cook, make sure the exterior of the reheating container and the interior of the oven are dry, to assure the best results.
- Room temperature should not exceed 95°F.
- Oven should be plugged in at least 5 minutes before sensor cooking.

## POTATO

SENSOR COOK allows you to cook most of your favorite foods without having to select cooking times and power levels. This oven automatically determines required cooking times for each food item.

**Example: To cook a potato**

**Touch:** **Display Shows:**

1.  Time of day.
2.  POTATO

(The oven will cook food automatically by sensor system.)

## SENSOR COOK OPERATION INSTRUCTION

Sensor Cook provides exciting new features to make microwaving easier. Sensor menu with all the popular food choices, helps you to reheat perfectly because it has been pre-programmed and can tell how long to reheat food items.

**Categories:**

**Popcorn, Potato, Rice, Reheat, Vegetable, Frozen Entree**

For most Sensor Cook programs, a table with specific food examples and cooking instructions is provided in the next a few pages.



- The Sensor Cook system works by detecting a build-up of vapor.
- Make sure the door remains closed.
- Once the vapor is detected, two beeps will sound.

## REHEAT

This feature allows you to reheat precooked room-temperature or refrigerated foods without selecting cooking times and power levels. This feature has 3 categories : dinner plate, soup/sauce, casserole. See the following table for more information.

**Example : To reheat casserole.**

**Touch:** **Display Shows:**

1.  Time of day.
2.  SELECT MENU 1 TO 3 -  
-SEE COOKING GUIDE
3.  CASSEROLE

(The oven will reheat food automatically by sensor system.)

# USING YOUR MICROWAVE OVEN

## SENSOR COOK TABLE

CATEGORY		DIRECTION	AMOUNT
Popcorn		Popcorn lets you pop commercially packaged microwave popcorn. Pop only one package at a time. For best results, use fresh bag of popcorn. Place bag of prepackaged microwave popcorn on the center of turntable.	3.0 - 3.5 oz. package
Potato		Pierce each potato with a fork and place on the glass turntable around the edge, at least one inch apart. After cooking, allow to stand for 3 minutes.	1 - 4 ea. (approx. 8~10 oz. each)
Rice		Place rice and twice as much liquid (water or chicken or vegetable stock) in a 2-quart microwavable dish. Cover with plastic wrap. After cooking, allow to stand for 10 minutes. Stir for fluffier rice.	1/2 - 2 cups Use medium or long grain rice. Cook instant rice according to directions on the package.
Reheat	Dinner plate	Place foods to be heated on dinner plate or similar dish. Cover with plastic wrap. After cooking, allow to stand for 3 minutes.	1-2 servings
	Soup/Sauce	Place foods to be heated in an appropriately sized microwave container. Cover with plastic wrap. After cooking, allow to stand for 3 minutes.	1-4 cups
	Casserole	Cover dish containing the casserole with plastic wrap. After cooking, allow to stand for 3 minutes.	1-4 cups
Vegetable	Fresh	Prepare as desired, wash, and leave residual water on the vegetables. Place in an appropriately-sized microwave container. Add amount of water according to the quantity. (1-2 cups : 2 tablespoons, 3-4 cups : 4 tablespoons) Cover with plastic wrap. After cooking, allow to stand for 3 minutes.	1-4 cups
	Frozen	Remove from package, rinse off frost under running water. Place in an appropriately-sized microwave container. Add amount of water according to the quantity. (1-2 cups : 2 tablespoons, 3-4 cups : 4 tablespoons) After cooking, allow to stand for 3 minutes.	1-4 cups
	Canned	Remove from the outer display can. Place in an appropriately sized microwave container, cover with plastic wrap and vent. After cooking, Stir and allow to stand for 3 minutes.	1-4 cups
Frozen Entree		Remove from outer display package. Vent the plastic film by piercing with a fork (3 times). If not in microwave safe container, place on plate, cover with plastic wrap and vent. After cooking, allow to stand for 3 minutes.	10 - 21 oz.





**NOTE:** If you open the door or press STOP/CLEAR during sensing, the process will be canceled.

# USING YOUR MICROWAVE OVEN

## HOMEMADE BAKERY

Homemade Bakery has 3 food categories of preset cooking time and power level.

**Example: To cook 3 pieces of muffin.**

Touch:	Display Shows:
1. 	Time of day.
2. 	<i>SELECT MENU 1 TO 3 - -SEE COOKING GUIDE</i>
3. 	<i>ROLL/MUFFIN TOUCH 1 TO 4 PIECES</i>
4. 	<i>3 PIECES ROLL/MUFFIN</i>





## HOMEMADE BAKERY TABLE

Category	Direction	Amount
<b>Roll/Muffin</b>	Place on oven tray or a plate.	1, 2, 3 or 4 pieces (2 ~ 3 oz. each)
<b>Pancake</b>	Place in stacks of three pancakes on an appropriate sized plate.	3 or 6 cakes Frozen
<b>French Toast</b>	Place french toast on an appropriate sized plate. Before serving, add butter, syrup, fruit jam, or whatever suits your taste. Note: Heat toppings for 20 ~ 30 seconds before adding to toast.	1, 2, 3 or 4 slices Frozen

## CHICKEN CHOICES

Chicken Choices have 4 food categories of preset cooking time and power level.

**Example: To cook 12oz. of chicken wing.**

Touch:	Display Shows:
1. 	Time of day.
2. 	<i>SELECT MENU 1 TO 4 - -SEE COOKING GUIDE</i>
3. 	<i>CHICKEN WINGS TOUCH 1 TO 2</i>
4. 	<i>12 OZ CHICKEN WINGS</i>

## CHICKEN CHOICES TABLE

Category	Direction	Amount
<b>Chicken Wings</b>	Place in a single layer around the edge of a dinner plate or serving platter.	6 or 12 oz. Frozen, Precooked
<b>Chicken Nuggets</b>	Place in a single layer around the edge of a dinner plate.	4 or 8 oz. Frozen, Precooked
<b>Spicy Chicken</b>	See the below recipe guide.	2 or 4 servings
<b>Mexican Chicken</b>	See the below recipe guide.	2 or 4 servings

### SPICY CHICKEN

- 2 servings (double the ingredients for 4 servings)

- 1 ½ pounds skinless, chicken pieces
- ½ teaspoon cayenne pepper
- 1 tablespoon paprika
- ½ teaspoon pepper
- ¼ cup hot sauce or 1 tablespoon Tabasco sauce
- ½ cup barbecue sauce of choice

Mix everything in an 8 X 8 inch-glass dish or similar dish and cover with plastic wrap. Cook on 'Spicy Chicken'. Stir and serve as is or place under a broiler for a few minutes for additional browning.

### MEXICAN CHICKEN

- 2 servings (double the ingredients for 4 servings)

- ½ medium onion, chopped
- ½ green bell pepper, diced
- ½ cup frozen peas
- ½ cup long grain rice
- 1 cup water
- ½ cup salsa
- 1 ½ pounds skinless, chicken pieces, legs, thighs, breasts, wings, or combination of all
- 1 teaspoon cumin
- Salt and pepper to taste
- ½ cup green olives w/pimentos

Place onions and peppers in an 8 X 8-inch glass dish or similar container and microwave for 3-minutes.

Add peas, rice, water, salsa, chicken, and cumin. Season with salt and pepper.

Cover with plastic wrap and cook on 'Mexican Chicken'. Stir in the olives and serve as is or place under a broiler for a few minutes to add additional browning.





# USING YOUR MICROWAVE OVEN

## CHILDREN'S LUNCH

Children's Lunch has 3 food categories of preset cooking time and power level.

**Example: To cook 15 oz. of canned pasta.**

**Touch:** **Display Shows:**





1.  Time of day.
2.  *SELECT MENU 1 TO 3-  
-SEE COOKING GUIDE*
3.  *CANNED PASTA  
TOUCH 1 TO 3*
4.  *15 OZ  
CANNED PASTA*

## FAST BREAKFAST

Fast Breakfast has 3 food categories of preset cooking time and power level.

**Example: To cook 2 scrambled eggs.**

**Touch:** **Display Shows:**

1.  Time of day.
2.  *SELECT MENU 1 TO 3-  
-SEE COOKING GUIDE*
3.  *SCRAMBLED EGGS  
TOUCH 1 TO 2*
4.  *2 EGGS  
SCRAMBLED EGGS*

## CHILDREN'S LUNCH TABLE

Category	Direction	Amount
<b>Hot dog buns</b>	Place on oven tray or a plate. Add hot dog after heating buns.	2 or 4 EA
<b>Frozen pizza</b>	Follow manufacturer's direction on the package.	6-8 inch individual pizza with a microwave disc
<b>Canned pasta</b>	Place in appropriate size microwave container and cover with paper towel or wax paper. Stir at beep and continue cooking.	7.5, 15 or 40 oz.

## FAST BREAKFAST TABLE

Category	Direction	Amount
<b>Oatmeal</b>	Prepare as directed on package and stir before serving. Use only instant hot cereal.	1, 2, 3 or 4 servings
<b>Bacon</b>	Lay on microwave bacon rack or other similar dish or a dinner plate covered with a paper towel and cover with a paper towel.	2, 4, 6 or 8 slices Regular sliced bacon
<b>Scrambled Eggs</b>	Beat eggs in a coffee mug or cereal bowl and cover with plastic wrap. Stir at beep, and continue cooking. Stir before serving. (Optional: Add 1 tbs of milk and 1 tsp of butter per one egg.)	2 or 4 eggs





# USING YOUR MICROWAVE OVEN

## TIMED COOKING

This feature lets you program a specific cook time and power. For best results, there are 10 power level settings in addition to HIGH power (100%). Refer to the "Microwave Power Level Table"

**NOTE:** If you do not select a power level, then the oven will automatically cook at HIGH(100%) power.

**Example: To cook for 5 minutes, 30 seconds at 50% power.**

**Touch:**

**Display Shows:**

1.  : ENTER COOKING TIME

2.    5 : 30 TOUCH START OR POWER

3.  5 : 30 ENTER POWER LEVEL 1 TO 10

4.  5 : 30 POWER 50 TOUCH START

5.  5 : 30 POWER 50  
(Starts cooking.)

When cooking is complete, four short tones will sound. The word *COOK END* shows in the display window. Then the oven shuts itself off.

## 2 STAGE TIMED COOKING

For Two Stage cooking, repeat timed cooking steps 2 through 5 on the previous page before touching the START pad for additional Time and Power program you want to add.

Auto Weight Defrost can be programmed before the first stage to defrost first and then cook.

## MICROWAVE POWER LEVELS

Your microwave oven is equipped with ten power levels to give you maximum flexibility and control over cooking. The table below will give you some idea of which foods are prepared at each of the various power levels.

\*The table below shows the power level settings for your oven.

**MICROWAVE POWER LEVEL TABLE**

Power Level	Use
10 (High)	*Boiling water. *Making candy. *Cooking poultry pieces, fish, & vegetables. *Cooking tender cuts of meat. *Whole poultry.
9	*Reheating rice, pasta, & vegetables.
8	*Reheating prepared foods quickly. *Reheating sandwiches.
7	*Cooking egg, milk and cheese dishes. *Cooking cakes, breads. *Melting chocolate.
6	*Cooking veal. *Cooking whole fish. *Cooking puddings and custard.
5	*Cooking ham, whole poultry, lamb. *Cooking rib roast, sirloin tip.
4	*Thawing meat, poultry and seafood.
3	*Cooking less tender cuts of meat. *Cooking pork chops, roast.
2	*Taking chill out of fruit. *Softening butter.
1	*Keeping casseroles and main dishes warm. *Softening butter and cream cheese.
0	* Standing time. * Independent.

# USING YOUR MICROWAVE OVEN

## AUTO DEFROST



Four defrost sequences are preset in the oven. The defrost feature provides you with the best defrosting method for frozen foods. The cooking guide will show you which defrost sequence is recommended for the food you are defrosting. With the Auto Defrost feature, the oven automatically sets the defrosting time and power levels for you. The oven automatically determines required defrosting times for each food item according to the weight you enter. For added convenience, the Auto Defrost includes a built-in beep mechanism that reminds you to check, turn over, separate, or rearrange.

- 1 MEAT
- 2 POULTRY
- 3 FISH
- 4 BREAD

\* Available weight is 0.1~6.0 lbs.  
(Bread weight is 0.1~1.0 lbs.)

**Example: To defrost 1.2 lbs. of ground beef.**

**Touch:** **Display Shows:**

- |                      |   |  |
|----------------------|---|--|
| 1.                   |    | Time of day.   |
| 2.                   |   | MEAT TOUCH 1<br>POULTRY TOUCH 2<br>FISH TOUCH 3<br>BREAD TOUCH 4 |
| 3.                   | <input type="text" value="1"/>  | 0.0 Lbs ENTER<br>WEIGHT  |
| 4.                   | <input type="text" value="1"/> and <input type="text" value="2"/>                   | 1.2 Lbs<br>TOUCH START   |
| To enter the weight. |   |  |
| 5.                   |  | DEFROST<br>(Starts defrosting.)                                  |

### NOTE:

When you touch the START pad, the display changes to defrost time count down. The oven will beep once during the DEFROST cycle.

At beep, open the door and turn over, separate, or rearrange the food.

Remove any portions that have thawed.

Return frozen portions to the oven and touch START to resume the defrost cycle.

\*For best results, remove fish, shellfish, meat, and poultry from its original closed paper or plastic package (wrapper). Otherwise, the wrap will hold steam and juice close to the foods, which can cause the outer surface of the foods to cook.

\*For best results, shape your ground meat into the form of a doughnut before freezing. When defrosting, scrape off thawed meat when the beep sounds and continue defrosting.

\*Place foods in a shallow container or on a microwave roasting rack to catch drippings.

\*Food should still be somewhat icy in the center when removed from the oven.

### AUTO DEFROST SEQUENCE LIST



Sequence	Food
<b>1 MEAT</b>	<b>BEEF</b> Ground beef, Round steak, Cubes for stew, Tenderloin steak, Pot roast, Rib roast, Rump roast, Chuck roast, Hamburger patty. <b>LAMB</b> Chops (1 inch thick), Rolled roast <b>PORK</b> Chops (1/2 inch thick), Hot dogs, Spareribs, Country-style ribs. Rolled roast, Sausage. <b>VEAL</b> Cutlets (1 lbs, 1/2 inch thick)
<b>2 POULTRY</b>	<b>POULTRY</b> Whole (under 4 lbs.), Cut-up, Breasts (boneless) <b>CORNISH HENS</b> Whole <b>TURKEY</b> Breast (under 6 lbs.)
<b>3 FISH</b>	<b>STEAKS/CHOPS</b> Round beef steak, Tenderloin steak Lamb chops (1 inch thick) Pork chops (1/2 inch thick) Veal cutlets (1 lbs, 1/2 inch thick) <b>FISH</b> Fillets, Whole Steaks <b>SHELLFISH</b> Crab meat, Lobster tails, Shrimp, Scallops
<b>4 BREAD</b>	Bagel Dinner Roll Muffin Hamburger Hot Dog Bun Slices of Bread Loaf of Bread

## Q DEFROST

This feature should be used only when you defrost 1 pound of frozen ground beef.

**Example: To defrost 1 lbs. Ground beef.**

**Touch:** **Display Shows:**

- |    |   |                                       |
|----|---|---------------------------------------|
| 1. |  | Time of day.                          |
| 2. |  | QUICK DEFROST<br>(Starts defrosting.) |

# USING YOUR MICROWAVE OVEN

## AUTO DEFROST TABLE

### Meat setting

FOOD	SETTING	AT BEEP	SPECIAL INSTRUCTIONS
<b>BEEF</b>			Meat of irregular shape and large, fatty cuts of meat should have the narrow or fatty areas shielded with foil at the beginning of a defrost sequence.
Ground Beef, Bulk	MEAT	Remove thawed portions with fork. Turn over. Return remainder to oven.	Do not defrost less than 1/4 lb. Freeze in doughnut shape.
Ground Beef, Patties	MEAT	Separate and rearrange.	Do not defrost less than 2 oz. patties. Depress center when freezing.
Round Steak	MEAT	Turn over. Cover warm areas with aluminum foil.	Place on a microwavable roasting rack.
Tenderloin Steak	MEAT	Turn over. Cover warm areas with aluminum foil.	Place on a microwavable roasting rack.
Stew Beef	MEAT	Remove thawed portions with fork. Separate remainder. Return remainder to oven.	Place in a microwavable baking dish.
Pot Roast, Chuck Roast	MEAT	Turn over. Cover warm areas with aluminum foil.	Place on a microwavable roasting rack.
Rib Roast	MEAT	Turn over. Cover warm areas with aluminum foil.	Place on a microwavable roasting rack.
Rolled Rump Roast	MEAT	Turn over. Cover warm areas with aluminum foil.	Place on a microwavable roasting rack.
<b>LAMB</b>			
Cubes for Stew	MEAT	Remove thawed portions with fork. Return remainder to oven.	Place in a microwavable baking dish.
Chops (1 inch thick)	MEAT	Separate and rearrange.	Place on a microwavable roasting rack.
<b>PORK</b>			
Chops (1/2 inch thick)	MEAT	Separate and rearrange.	Place on a microwavable roasting rack.
Hot Dogs	MEAT	Separate and rearrange.	Place on a microwavable roasting rack.
Spareribs Country-style Ribs	MEAT	Turn over. Cover warm areas with aluminum foil.	Place on a microwavable roasting rack.
Sausage, Links	MEAT	Separate and rearrange.	Place on a microwavable roasting rack.
Sausage, Bulk	MEAT	Remove thawed portions with fork. Turn over. Return remainder to oven.	Place in a microwavable baking dish.
Loin Roast, Boneless	MEAT	Turn over. Cover warm areas with aluminum foil.	Place on a microwavable roasting rack.

# USING YOUR MICROWAVE OVEN

## AUTO DEFROST TABLE (CONT.)

### Poultry setting

FOOD	SETTING	AT BEEP	SPECIAL INSTRUCTIONS
<b>CHICKEN</b> Whole	POULTRY	Turn over (finish defrosting breast-side down). Cover warm areas with aluminum foil.	Place chicken breast-side up on a microwavable roasting rack. Finish defrosting by immersing in cold water. Remove giblets when chicken is partially defrosted.
Cut-up		Separate pieces and rearrange.  Turn over. Cover warm areas with aluminum foil.	Place on a microwavable roasting rack.  Finish defrosting by immersing in cold water.
<b>CORNISH HENS</b> Whole	POULTRY	Turn over. Cover warm areas with aluminum foil.	Place on a microwavable roasting rack. Finish defrosting by immersing in cold water.
<b>TURKEY</b> Breast	POULTRY	Turn over. Cover warm areas with aluminum foil.	Place on a microwavable roasting rack. Finish defrosting by immersing in cold water.

### Fish setting

FOOD	SETTING	AT BEEP	SPECIAL INSTRUCTIONS
<b>FISH</b> Fillets	FISH	Turn over. Separate fillets when partially thawed if possible.	Place in a microwavable baking dish. Carefully separate fillets under cold water.
Steaks	FISH	Separate and rearrange.	Place in a microwavable baking dish. Run cold water over to finish defrosting.
Whole	FISH	Turn over.	Place in a microwavable baking dish. Cover head and tail with foil; do not let foil touch sides of microwave. Finish defrosting by immersing in cold water.
<b>SHELLFISH</b> Crabmeat	FISH	Break apart. Turn over.	Place in a microwavable baking dish.
Lobster tails	FISH	Turn over and rearrange.	Place in a microwavable baking dish.
Shrimp	FISH	Separate and rearrange.	Place in a microwavable baking dish.
Scallops	FISH	Separate and rearrange.	Place in a microwavable baking dish.

### Bread setting

FOOD	SETTING	AT BEEP	SPECIAL INSTRUCTIONS
Bagel Dinner Roll Muffin Hamburger Hot Dog Bun Slices of Bread Loaf of Bread	BREAD	Turn over and rearrange.	Place on 3 sheets of paper towel.

# HEATING/REHEATING GUIDE

To heat or reheat successfully in a microwave oven, it is important to follow several guidelines. Measure the amount of food in order to determine the time needed to reheat. Arrange the food in a circular pattern for best results. Room temperature food will heat faster than refrigerated food. Canned foods should be taken out of the can and placed in a microwave-safe container. The food will heat more evenly if covered with a microwave-safe lid or vented plastic wrap. Remove cover carefully to prevent steam burns. Use the following table as a guide for reheating cooked food.

ITEMS	COOK TIME (AT HIGH)	SPECIAL INSTRUCTIONS
Sliced meat 3 slices (1/4-inch thick)	1/2-1 minute	Place sliced meat on microwavable plate. Cover with plastic wrap and vent. Note: Gravy or sauce helps to keep meat juicy.
Chicken pieces 1 breast 1 leg and thigh	1-2 minutes 1/2-1 1/2 minutes	Place chicken pieces on microwavable plate. Cover with plastic wrap and vent.
Fish fillet (6-8 oz.)	1-2 minutes	Place fish on microwavable plate. Cover with plastic wrap and vent.
Lasagna 1 serving (10 1/2 oz.)	3-5 minutes	Place lasagna on microwavable plate. Cover with plastic wrap and vent.
Casserole 1 cup 4 cups	2-3 minutes 7-9 minutes	COOK covered in microwavable casserole. Stir once halfway through cooking.
Casserole – cream or cheese 1 cup 4 cups	2-3 minutes 6-8 minutes	COOK covered in microwavable casserole. Stir once halfway through cooking.
Sloppy Joe or Barbecued Beef 1 sandwich (1/2 cup meat filling) without bun	1/2-1 1/2 minutes	Reheat filling and bun separately. Cook filling covered in microwavable casserole. Stir once. Heat bun as directed in table below.
Mashed potatoes 1 cup 4 cups	1-3 minutes 5-8 minutes	COOK covered in microwavable casserole. Stir once halfway through cooking.
Baked beans 1 cup	1-2 minutes	COOK covered in microwavable casserole. Stir once halfway through cooking.
Ravioli or pasta in sauce 1 cup 4 cups	1-3 minutes 5-7 minutes	COOK covered in microwavable casserole. Stir once halfway through cooking.
Rice 1 cup 4 cups	1/2-1 minute 2-4 minutes	COOK covered in microwavable casserole. Stir once halfway through cooking.
Sandwich roll or bun 1 roll	10-20 seconds	Wrap in paper towel and place on glass microwavable rack
Vegetables 1 cup 4 cups	1-2 minutes 2-4 minutes	COOK covered in microwavable casserole. Stir once halfway through cooking.
Soup 1 serving (8 oz.)	1-2 minutes	COOK covered in microwavable casserole. Stir once halfway through cooking.

# FRESH VEGETABLE GUIDE

Vegetable	Amount	Cook Time at High (Minute)	Instructions	Standing Time
Artichokes (8 oz. each)	2 medium 4 medium	2-4 3-5	Trim. Add 2 tsp water and 2 tsp juice. Cover.	2-3 minutes
Asparagus, Fresh, Spears	1 lb.	3-4	Add ½ cup water. Cover.	2-3 minutes
Beans, Green & Wax	1 lb.	4-6	Add ½ cup water in 1½ qt. casserole. Stir halfway through cooking.	2-3 minutes
Beets, Fresh	1 lb.	4-7	Add ½ cup water in 1½ qt. covered casserole. Rearrange halfway through cooking.	2-3 minutes
Broccoli, Fresh, Spears	1 lb.	3-4	Place broccoli in baking dish. Add ½ cup water.	2-3 minutes
Cabbage, Fresh, Chopped	1 lb.	3-4	Add ½ cup water in 1½ qt. covered casserole. Stir halfway through cooking.	2-3 minutes
Carrots, Fresh, Sliced	2 cups	2-3	Add ¼ cup water in 1 qt. covered casserole. Stir halfway through cooking.	2-3 minutes
Cauliflower, Fresh, Whole	1 lb.	3-5	Trim. Add ¼ cup water in 1 qt. covered casserole. Stir halfway through cooking.	2-3 minutes
Flowerettes, Fresh	2 cups	2-3	Slice. Add ½ cup water in 1½ qt. covered casserole.	2-3 minutes
Celery, Fresh, Sliced	4 cups	3-4	Stir halfway through cooking.	2-3 minutes
Corn, Fresh	2 ears	2-3	Husk. Add 2 tbsp water in ½ qt. baking dish. Cover.	2-3 minutes
Mushrooms, Fresh, Sliced	½ lb.	1½-2	Place mushrooms in 1½ qt. covered casserole. Stir halfway through cooking.	2-3 minutes
Parsnips, Fresh, Sliced	1 lb.	2-4	Add ½ cup water in 1½ qt. covered casserole. Stir halfway through cooking.	2-3 minutes
Peas, Green, Fresh	4 cups	3-5	Add ½ cup water in 1½ qt. covered casserole. Stir halfway through cooking.	2-3 minutes
Sweet Potatoes Whole Baking (6-8 oz. each)	2 medium 4 medium	5-6 10-13	Pierce potatoes several times with fork. Place on 2 paper towels. Turn over halfway through cooking.	2-3 minutes 2-3 minutes
White Potatoes, Whole Baking (6-8 oz. each)	2 potatoes 4 potatoes	5-7 10-13	Pierce potatoes several times with fork. Place on 2 paper towels. Turn over halfway through cooking.	2-3 minutes 2-3 minutes
Spinach, Fresh, Leaf	1 lb.	2-4	Add ½ cup water in 2 qt. covered casserole.	2-3 minutes
Squash, Acorn or Butternut, Fresh	1 medium	3-5	Cut squash in half. Remove seeds. Place in 8 x 8-inch baking dish. Cover.	2-3 minutes
Zucchini, Fresh, Sliced	1 lb.	3-4	Add ½ cup water in 1½ qt. covered casserole. Stir halfway through cooking.	2-3 minutes
Zucchini, Fresh, Whole	1 lb.	3-5	Pierce. Place on 2 paper towels. Turn over and rearrange halfway through cooking.	2-3 minutes

# TROUBLESHOOTING

## Questions and Answers

### Operation

Question	Answer
Why is the oven light not on during cooking?	There may be several reasons why the oven light is not on. Have you: <ul style="list-style-type: none"> <li>• Set a cook time?</li> <li>• Touched START?</li> </ul>
Why does steam come out of the air exhaust vent?	Steam is normally produced during cooking. The microwave oven has been designed to vent this steam.
Will the microwave oven be damaged if it operates empty?	Yes. Never operate the oven empty or without the glass turntable.
Does microwave energy pass through the viewing screen in the door?	No. The metal screen bounces the energy back to the oven cavity. The holes (or ports) allow only light to pass through. They do not let microwave energy pass through.
Why does a tone sound when a pad on the control panel is touched?	The tone tells you that the setting has been entered.
Can my microwave oven be damaged if food is cooked for too long?	Like any other cooking appliance, it is possible to overcook food to the point that the food creates smoke and even possibly fire and damage to the inside of the oven. It is always best to be near the oven while you are cooking.
When the oven is plugged into wall outlet for the first time, it might not work properly. What is wrong?	The microcomputer controlling your oven may temporarily become scrambled and fail to function as programmed when you plug in for the first time or when power resumes after a power interruption. Unplug the oven from the 120-volt household outlet and then plug it back in to reset the microcomputer.
Why do I see light reflection around the outer case?	This light is from the oven light which is located between the oven cavity and the outer wall of the oven.
What are the various sounds I hear when the microwave oven is operating?	The clicking sound is caused by a mechanical switch turning the microwave oven's magnetron ON and OFF. The heavy hum and clunk is from the change in power the magnetron draws as it is turned ON and OFF by a mechanical switch. The change in blower speed is from the change in line voltage caused by the magnetron being turned ON and OFF.

### Food

Question	Answer
What is wrong when baked foods have a hard, dry, brown spot?	A hard, dry, brown spot indicates overcooking. Shorten the cooking or reheating time.
Why do eggs sometimes pop?	When baking, frying, or poaching eggs, the yolk may pop due to steam build-up inside the yolk membrane. To prevent this, simply pierce the yolk before cooking. <b>CAUTION:</b> Never microwave eggs in the shell.

# TROUBLESHOOTING

## Questions and Answers (continued)

### Food

Question	Answer
Why are scrambled eggs sometimes a little dry after cooking?	Eggs will dry out when they are overcooked, even if the same recipe is used each time. The cooking time may need to be varied for one of these reasons: <ul style="list-style-type: none"> <li>• Eggs vary in size.</li> <li>• Eggs are at room temperature one time and at refrigerator temperature another time.</li> <li>• Eggs continue cooking during standing time.</li> </ul>
Is it possible to pop popcorn in a microwave oven?	Yes, if using one of the two methods described below: <ol style="list-style-type: none"> <li>(1) microwave-popping devices designed specifically for microwave cooking</li> <li>(2) prepackaged commercial microwave popcorn that is made for specific times and power output needed</li> </ol> <p><b>Follow exact directions given by each manufacturer for its popcorn popping product and do not leave the oven unattended while the corn is being popped. If corn fails to pop after the suggested time, discontinue cooking. Overcooking could result in an oven fire.</b></p> <p><b>CAUTION:</b></p> <ul style="list-style-type: none"> <li>• <b>Never use a brown paper bag for popping corn or attempt to pop leftover kernels.</b></li> <li>• <b>Do not pop prepackaged commercial microwave popcorn directly on the glass turntable. To avoid excessive heating of the glass turntable, place the popcorn bag on a plate.</b></li> <li>• <b>Listen while corn pops. Stop oven when popping slows to 2-3 seconds between pops.</b></li> <li>• <b>Do not leave microwave unattended while popping corn.</b></li> <li>• <b>Follow directions on bag.</b></li> </ul>
Why do baked apples sometimes burst during cooking?	The peel has not been removed from the top half of each apple to allow for expansion of the interior of the apple during cooking. As in conventional cooking methods, the interior of the apple expands during the cooking process.
Why do baked potatoes sometimes burn during cooking?	If the cooking time is too long, fire could result. At the end of the recommended cooking time, potatoes should be slightly firm. <p><b>CAUTION: Do not overcook.</b></p>
Why is a standing time recommended after microwave cooking time is over?	Standing time allows foods to continue cooking evenly for a few minutes after the actual microwave oven cooking cycle. The amount of standing time depends upon the density of the foods.
Why is additional time required for cooking food stored in the refrigerator?	As in conventional cooking, the initial temperature of food affects total cooking time. You need more time to cook food taken out of a refrigerator than for food at room temperature.



# TROUBLESHOOTING

## Before Calling for Service

You can often correct operating problems yourself. If your microwave oven fails to work properly, locate the operating problem in the list below and try the solutions listed for each problem.

If the microwave oven still does not work properly, contact the nearest LG Authorized Service Center. LG Authorized Service Centers are fully equipped to handle your service requirements.

Problem	Possible Causes
Oven does not start	<ul style="list-style-type: none"> <li>• Is the power cord plugged in?</li> <li>• Is the door closed?</li> <li>• Is the cooking time set?</li> </ul>
Arcing or Sparking	<ul style="list-style-type: none"> <li>• Are you using approved cookware?</li> <li>• Is the oven empty?</li> </ul>
Incorrect time of day	<ul style="list-style-type: none"> <li>• Have you tried to reset the time of day?</li> </ul>
Unevenly Cooked Foods	<ul style="list-style-type: none"> <li>• Are you using approved cookware?</li> <li>• Is the glass turntable in the oven?</li> <li>• Did you turn or stir the food while it was cooking?</li> <li>• Were the foods completely defrosted?</li> <li>• Was the time/cooking power level correct?</li> </ul>
Overcooked Foods	<ul style="list-style-type: none"> <li>• Was the time/cooking power level correct?</li> </ul>
Undercooked Foods	<ul style="list-style-type: none"> <li>• Are you using approved cookware?</li> <li>• Were the foods completely defrosted?</li> <li>• Was the time/cooking power level correct?</li> <li>• Are the ventilation ports clear?</li> </ul>
Improper Defrosting	<ul style="list-style-type: none"> <li>• Are you using approved cookware?</li> <li>• Was the time/cooking power level correct?</li> <li>• Did you turn or stir the food during the defrosting cycle?</li> </ul>

### FEDERAL COMMUNICATIONS COMMISSION RADIO FREQUENCY INTERFERENCE STATEMENT

**WARNING:**

This equipment generates and uses ISM frequency energy and if not installed and used properly, that is in strict accordance with the manufacturer's instructions, may cause interference to radio and television reception. It has been type tested and found to comply with limits for ISM Equipment pursuant to part 18 of FCC Rules, which are designed to provide reasonable protection against such interference in a residential installation.

However, there is no guarantee that interference will not occur in a particular installation. If this equipment does cause interference to radio or television reception, which can be determined by turning the equipment off and on, the user is encouraged to try to correct the interference by one or more of the following:

- Reorient the receiving antenna of the radio or television.
- Relocate the microwave oven with respect to the receiver.
- Move the microwave oven away from the receiver.
- Plug the microwave oven into a different outlet so that the microwave oven and the receiver are on different branch circuits.

**The manufacturer** is not responsible for any radio or TV interference caused by **unauthorized modification** to this microwave oven. It is the responsibility of the user to correct such interference.

# LG MICROWAVE OVEN LIMITED WARRANTY – USA

LG Electronics Inc. will repair or replace your product, at LG's option, if it proves to be defective in material or workmanship under normal use, during the warranty period set forth below, effective from the date of original consumer purchase of the product. This limited warranty is good only to the original purchaser of the product and effective only when used in the United States, including U.S. Territories.

<p><b><u>WARRANTY PERIOD:</u></b></p> <p><b>Model:</b> LRMM1430SW/LRMM1430SB</p> <p><b>Labor:</b> 1 Year from the Date of Purchase.</p> <p><b>Parts:</b> 1 Year from the Date of Purchase.</p> <p><b>Magnetron:</b> 10 Years from the Date of Purchase.</p>	<p><b><u>HOW SERVICE IS HANDLED:</u></b></p> <p>Call 1-877-714-7486 and choose the appropriate prompt. Please have product type (Microwave) and ZIP code ready.</p>
---	---

**THIS WARRANTY IS IN LIEU OF ANY OTHER WARRANTIES, EXPRESS OR IMPLIED, INCLUDING WITHOUT LIMITATION, ANY WARRANTY OF MERCHANTABILITY OR FITNESS FOR A PARTICULAR PURPOSE. TO THE EXTENT ANY IMPLIED WARRANTY IS REQUIRED BY LAW, IT IS LIMITED IN DURATION TO THE EXPRESS WARRANTY PERIOD ABOVE. LG WILL NOT BE LIABLE FOR ANY CONSEQUENTIAL, INDIRECT, OR INCIDENTAL DAMAGES OF ANY KIND, INCLUDING LOST REVENUES OR PROFITS, IN CONNECTION WITH THE PRODUCT. SOME STATES DO NOT ALLOW LIMITATION ON HOW LONG AN IMPLIED WARRANTY LASTS OR THE EXCLUSION OF INCIDENTAL OR CONSEQUENTIAL DAMAGES, SO THE ABOVE LIMITATIONS OR EXCLUSIONS MAY NOT APPLY TO YOU.**

**THIS LIMITED WARRANTY DOES NOT APPLY TO:**

1. Service trips to your home to deliver, pick up, and/or install the product, instruct, or replace house fuses or correct wiring, or correction of unauthorized repairs; and
2. Damages or operating problems that result from misuse, abuse, operation outside environmental specifications or contrary to the requirements or precautions in the Operating Guide, accident, vermin, fire, flood, improper installation, acts of God, unauthorized modification or alteration, incorrect electrical current or voltage, or commercial use, or use for other than intended purpose.

**Therefore, the cost of repair or replacement of such a defective product shall be borne by the consumer.**

**CUSTOMER INTER-ACTIVE CENTER NUMBERS:**

<p><b>To Prove Warranty Coverage</b></p>	<p><b>Retain your Sales Receipt to prove date of purchase.</b> A copy of your Sales Receipt must be submitted at the time warranty service is provided.</p>
<p><b>To Obtain Nearest Authorized Service Center or Sales Dealer, or to Obtain Product, Customer, or Service Assistance</b></p>	<p><b>Call 1-877-714-7486</b> (Phone answered 24 hours - 365 days a year) and choose the appropriate prompt from the menu; or visit our website at: <a href="http://www.lgservice.com">http://www.lgservice.com</a>.</p>



P/NO.: 3828W5A3194

Printed in Korea