

# Crane

Adorable Humidifiers

## INSTRUCTION MANUAL

**1 GALLON/ 3.78 LITER  
ULTRASONIC HUMIDIFIER**

**MODELS #EE-0865 through #EE-5058**



**PLEASE READ AND SAVE ALL INSTRUCTIONS TO ENSURE  
THE SAFE AND EFFECTIVE USE OF THIS HUMIDIFIER.**

<b>TABLE OF CONTENTS</b>	
Table of Contents, Humidifier Models	P. 1
Important Safety Instructions	P. 2
General Safety Instructions	P. 3
List of Main Parts	P. 4
Technical Specifications, Contents of Packaging	P. 5
Operation and Use	P. 5-8
Maintenance	P. 8-9
Trouble Shooting	P. 9
Service Center	P. 10
Warranty Information	P. 11
Warranty Card	P. 12
Order Form	P. 13

## **HUMIDIFIER MODELS**

This instruction manual applies to the following models of the Adorable Humidifiers product line:

<b>Animal Type</b>	<b>Model #</b>	<b>Animal Type</b>	<b>Model #</b>
Penguin	EE-0865	Pig	EE-4139
Elephant	EE-3186	Cow	EE-4140
Panda	EE-3189	Duck	EE-6369
Dog	EE-3190	Leopard	EE-6524
Frog	EE-3191	Dragon	EE-5058
		Tiger	EE-7270

**For information about all CRANE Humidifiers, please visit <http://www.crane-usa.com> for retail outlet locations.**



## IMPORTANT SAFETY INSTRUCTIONS

Thank you for purchasing our CRANE Ultrasonic Humidifier. Each unit has been manufactured to ensure safety and reliability. Before using for the first time, please read the instructions carefully and keep them for further reference.

**WARNING! READ AND SAVE THESE INSTRUCTIONS.** Failure to follow all of the instructions listed below may result in electric shock, fire and/or serious personal injury.

1. **Do not carry Water Tank by handle when it is filled with water. It is advisable to carry filled Water Tank with two hands.**
2. **DO NOT operate outdoors. This humidifier is intended for indoor use only.**
3. Always have water in the Water Tank when operating the unit.
4. Use only clean, cool tap water to fill the Water Tank (filtered or distilled water is recommended to avoid white dust if tap water is too hard; demineralization filters are also available for purchase at [www.crane-usa.com](http://www.crane-usa.com)). **DO NOT use hot water.**
5. Be sure that the Water Tank Cap is firmly tightened on Water Tank. Always have the Water Tank Lid in place while the unit is operating. Place the humidifier so the mist aims away from children, walls, furniture and electrical appliances.
6. Use only a 110-120VAC outlet. **ALWAYS plug and unplug unit with dry hands to avoid electric shock.**
7. Never operate the unit with a damaged Cord or Plug.
8. Always place the unit on a smooth, flat, lint-free, non-metallic, waterproof and level surface and position unit away from direct sunlight. Keep the cord away from heated surfaces and areas where it could be walked on or tripped over. Unplug the unit when not in use and whenever you clean or move the unit.
9. Do not add medication of any type into the Water Basin or Water Tank. Do not cover any openings on the unit or insert objects into any openings.
10. The unit should not be left unattended in a closed room as the air could become saturated and leave condensation on walls or furniture. Leave room door partly open when humidifier is being operated.
11. When cleaning the inside of the humidifier, keep water away from the Fan Vent. **Turn off and unplug the humidifier to wipe the exterior** (except the electrical controls) with a damp cloth. Humidifier requires regular cleaning. Please refer to the CLEANING INSTRUCTIONS in this manual.
12. Do not tilt or tip the humidifier or attempt to empty or fill it while it is in operation.
13. Do not use a detergent to clean any parts of the unit that contain water. Detergent film dissolved in the water supply can interfere with the output of the unit. Instead, always use a few drops of white vinegar mixed with water to clean the humidifier.

## SAVE THESE INSTRUCTIONS!

## GENERAL SAFETY INSTRUCTIONS



**WARNING!** Read and understand all instructions. Failure to follow all instructions listed below may result in electric shock, fire or serious personal injury. The warnings, cautions, and instructions discussed in this instruction manual cannot cover all possible conditions and situations that may occur. It must be understood by the user that common sense and caution are a factor which cannot be built into this product, but must be supplied by the user.

### **THIS HUMIDIFIER IS NOT A TOY!**

**Do not let your child play with this humidifier.** Serious injury and electrocution might be possible. This humidifier has to be operated by an adult only. Children should be supervised to ensure that they do not play with the humidifier.

### **SAVE ALL INSTRUCTIONS!**

**CAUTION:** A short Power Supply Cord is provided to reduce the risk of personal injury resulting from becoming entangled in or tripping over a longer cord. Extension cords are available from local hardware stores and may be used if care is exercised in their use. If an extension cord is required, special care and caution is necessary. Also the extension cord must be (1) marked with an electrical rating of 125 V and at least 13 A., 1625 W., and (2) the cord must be arranged so that it will not drape over the countertop or tabletop where it can be pulled on by children or accidentally tripped over.

#### **ELECTRIC POWER**

If the electric circuit is overloaded by other appliances, your humidifier and/or appliances may not operate properly. The humidifier should be operated on a separate electrical circuit from other operating appliances.

#### **POLARIZED PLUG**

This humidifier has a polarized plug (one blade is wider than the other). As a safety feature to reduce the risk of electrical shock, this plug is intended to fit in a polarized outlet only one way. If the plug does not fit fully in the outlet, reverse the plug. If it still does not fit, contact a qualified electrician. Do not attempt to defeat this safety feature.



#### **SAFETY WARNING**

Although your humidifier is easy to operate, for your safety, the below warnings must be followed:

1. Do not place the humidifier near a heat source.
2. Never leave the humidifier unattended while connected to the electrical outlet.
3. To avoid any accidents, never cover the Mist Outlet Slots when the humidifier is in operation.
4. Use the humidifier on a smooth, flat, lint-free, non-metallic, waterproof and level surface away from water.
5. Do not unplug from the wall socket by pulling on the supply cord.
6. The humidifier must be unplugged:
  - A. Before either filling or emptying the Water Basin and/or Water Tank.
  - B. Before any cleaning or maintenance is performed.
  - C. After each use.
  - D. If it appears to be faulty.

**THIS PRODUCT IS INTENDED FOR HOUSEHOLD USE ONLY.**

## LIST OF MAIN PARTS

**Fig. 1 (Central Body)**

1. Central Body (water basin)
2. Control Knob ON/OFF
3. Power Indicator Light

**(NOTE: Depending on the model, your humidifier may have one or two indicator lights.)**

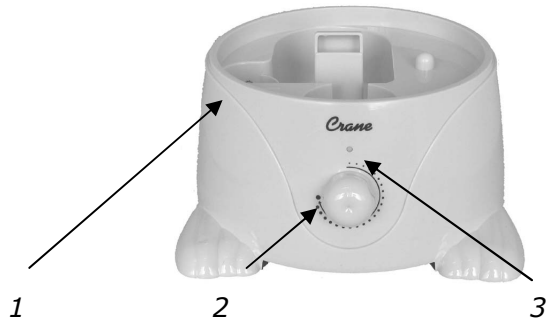

**Fig. 2 (Top of Water Tank)**

4. Mist Outlet Channel
5. Water Tank Handle

**(NOTE: Shape of Water Tank depends on model #)**

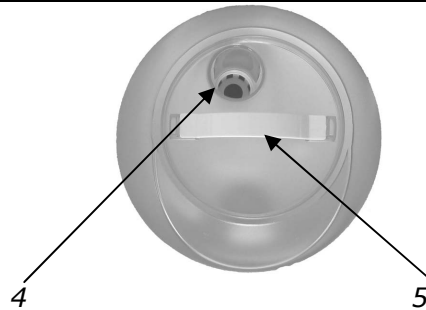

**Fig. 3 (Water Basin)**

6. Water Level Sensor
7. Nebulizer
8. Valve Opener
9. Fan Channel
10. Mist Chamber

**(NOTE: Shape of Water Basin depends on model #)**

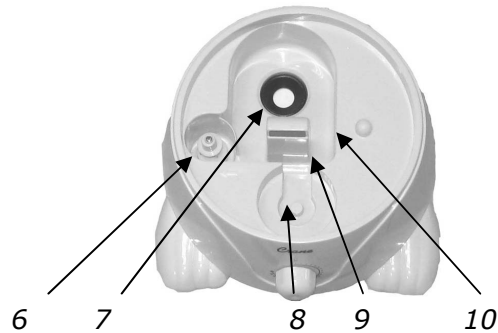

**Fig. 4 (Bottom of Water Tank)**

11. Water Tank Valve
12. Water Tank Cap
13. Mist Outlet Channel

**(NOTE: Shape of Water Tank depends on model #)**

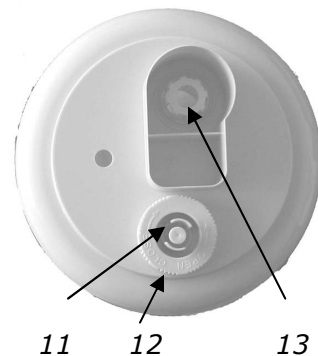

**Fig. 5 (Water Tank Mist Lid)**

14. Water Tank Mist Lid
15. Mist Output Slots

**(NOTE: Shape of Central Body depends on model #)**



## TECHNICAL SPECIFICATIONS:

Rating Voltage	120V
Frequency	60Hz
Water Tank Capacity	Approx. 1.0 Gallon/3.78 Liter
Output Per 24 Hours	Approx. 2.1 Gallon/8 Liter
Run Time Per Tank	Max. up to 24 hours/Min 11 Hours
Humidifying Capacity	Up to 250 sq.ft. /23 m <sup>2</sup>
Noise	<36.5 (dB) A

## CONTENTS OF PACKAGING

- a. Instruction Manual
- b. Central Humidifier Body
- c. Water Tank
- d. Water Tank Mist Lid with Mist Output Slots

If any of the above items are missing, please contact our Customer Service department at 1-888-599-0992 (<http://www.crane-usa.com>) for replacement. Business hours: Mon-Fri 9:00 am - 4:00 pm CT

## OPERATION AND USE

### BEFORE EACH USE

#### CHECK HUMIDIFIER PLACEMENT

Place the Humidifier on an elevated, non-metallic, lint-free, waterproof, level surface at least 5 inches away from walls and heat sources.

**DO NOT** place on carpet or towel. The fan vent is located on the bottom of the water basin. The fan vent **MUST NOT** be obstructed.

**DO NOT** place the humidifier on a wood surface or near furniture that can be damaged by too much moisture.

**CHECK WATER LEVEL SENSOR** - Make sure that the Water Level Sensor is secured properly.

#### CHECK FAN VENT

The Fan Vent is located on the bottom of the humidifier. The purpose of the Fan Vent is to blow the cool mist through the Mist Outlet Slots. It is important that this part be kept clean and free of obstructions. We recommend checking the fan vent before using this item (i.e., free of lint, paper, etc.).

**Do not place the humidifier on top of a towel or a carpeted surface. The Fan Vent on the bottom may become blocked and overheat the humidifier!**

#### CAUTION:

**DO NOT operate the humidifier without water in the Water Tank.**

**DO NOT plug or unplug the Power Cord with wet hands as electric shock could occur.**

## ASSEMBLY

**ALWAYS use fresh cool water when operating the humidifier.**

1. Lift the Water Tank off the Central Body.
2. Turn over the Water Tank and unscrew the Water Tank Cap at the bottom of the tank by turning it counterclockwise.



3. Fill Water Tank with cold water. **DO NOT** fill water all the way to the rim. **DO NOT CARRY FULL WATER TANK BY HANDLE. ALWAYS HOLD WATER TANK WITH TWO HANDS ON EITHER SIDE OF WATER TANK.**



**Note:** To avoid possible white dust accumulation due to hard water, it is recommended to use filtered or distilled water. Use of an optional Crane Demineralization Filter is available at [www.crane-usa.com](http://www.crane-usa.com).

**DO NOT** use hot water. Use cool tap water.

**DO NOT** add any medication or other additives to the water.

**DO NOT** pour water into Mist Outlet Channel.

4. Replace the Water Tank Cap by aligning the threads on the Water Tank with the threads on the Cap and turning it clockwise.



5. Turn the Water Tank over and place the full Water Tank on the Central Body, making sure it fits perfectly. Place the Water Tank Cap with Mist Output Slots on top of the Water Tank.

**Note:** Do not attempt to move the humidifier while Water Tank is placed on the Water Basin. Doing so may cause leakage of water. Also do not place humidifier on the floor. Place humidifier on an elevated, non-metallic, lint-free, waterproof, level surface for best performance.

6. Plug the Power Cord into a wall socket and turn on the unit by using the Control Knob.
7. The indicator light will turn to red. In a few seconds it will switch to green, indicating that there is enough water in the Water Basin. Mist will begin emitting through the Mist Output Slots.

8. Use the Control Knob to adjust the intensity of the mist output. Turning the knob clockwise will increase the moisture output. Turning the knob counterclockwise will reduce the moisture output.  
**Note:** When set at the maximum level, it is normal to hear a faint dripping sound.
9. When the humidifier runs out of water, the indicator light will turn red and the mist output will stop. This is a safety feature to prevent the humidifier from possibly overheating and damaging the Nebulizer. This safety feature uses a Water Level Sensor to stop the Nebulizer once the water level sinks below the required level in the Water Basin. Turn the humidifier off and unplug the unit before removing and refilling the Water Tank. **Please note that the indicator light on the humidifier water basin will stay on. The (red) light indicates that the humidifier is turned on and needs to be refilled.**

**INSERTING OPTIONAL HUMIDIFIER FILTER**  
**(Filters are not included with the humidifier and can be purchased separately from Crane USA.)**

A humidifier filter is an optional accessory for your Crane Cool Mist Humidifier. Filters are used to reduce white dust caused by hard water.

Soak humidifier filter in water for 30 minutes to activate performance. Place humidifier filter inside Water Tank.

**NOTE:** Do not leave the filter inside humidifier longer than the recommended time. (See filter instructions on filter box packaging.)



**SET THE CORRECT HUMIDITY OUTPUT**

**Always place the humidifier on an elevated, non-metallic, lint-free, waterproof, level surface for best performance.**

Adjust the Control Knob so that the mist rises up to be absorbed by the room air. Do not set Control Knob too high as the mist cannot be absorbed by the air and may accumulate on the surfaces around the humidifier.

If the humidifier is placed near a fan or air conditioning outlet the mist may be forced down by the foreign air stream. Change the location of the humidifier or reduce the output of the other room conditioning appliances.

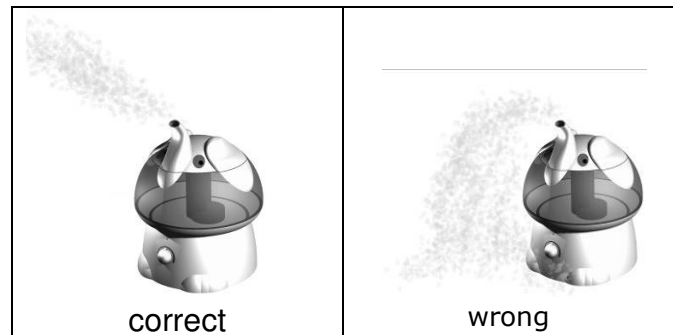



## **A NOTE ABOUT HUMIDITY**

- It is best to keep the humidity level at about 40%-50% of relative humidity.
- The comfort level of humidity will vary from room to room and with changing room conditions.
- In cold weather, windows and even some walls may fog or develop frost from excessive indoor humidity. If this occurs, reduce the mist intensity setting to avoid damage from condensed water dripping onto windowsills.
- Too much humidity in the room may allow moisture to accumulate on surfaces where bacteria and fungi can grow. Moisture that gathers may also damage furniture and walls, especially wallpaper.
- To reduce excessive humidity, especially in small rooms, leave the room door open and adjust the mist intensity control setting.

## **MAINTENANCE**

It is important to keep Cool mist humidifiers clean. Cleaning and disinfecting on a regular basis is important for maintaining the performance of your humidifier

**DO NOT leave water in Water Tank or Water Basin when unit is not in use as it may result in the build up of mineral deposits and bacteria that can inhibit the output efficiency of the humidifier. PLEASE NOTE that if water remains in the Water Tank for more than a day or two, bacterial growth is possible.**

### **DAILY MAINTENANCE**

1. Always turn off and unplug humidifier from outlet before cleaning.
2. Empty water from the Water Tank and Water Basin daily.
3. Wipe and dry Water Basin with a clean, dry cloth or paper towel.
4. Replace the clean Water Tank on the Water Basin. You are now ready to use your humidifier.

### **WEEKLY MAINTENANCE**

1. Always turn off and unplug humidifier from outlet before cleaning.
2. Remove the Water Tank from the Central Body and empty the water from both the Water Tank and the Water Basin.
3. Fill the Water Tank with ½-gallon of warm water. Add 2 Tablespoons of white vinegar. Shake vigorously and allow to sit for 20 minutes. Shake vigorously again and empty the water. Rinse the Water Tank a few times to get rid of the vinegar smell.
4. Make the same white vinegar water solution and pour into the Water Basin. Let sit for 20 minutes then empty. Rinse with only water a few times to remove any vinegar smell. Wipe dry with a clean soft cloth.
5. Wipe the exterior surfaces of Water Tank and Water Basin with a soft, dry cloth.  
**NEVER IMMERSER WATER BASIN IN WATER.**

### **END-OF-SEASON MAINTENANCE**

1. Remove the Water Tank from the Central Body. Empty the water from the Water Tank and the Water Basin.
2. Disinfect Water Tank and Water Basin with the white vinegar and water solution described above.
3. Make sure that Water Tank has air dried without the Water Cap secured.
4. Make sure the Water Basin and Water Tank are completely dry before end-of-season storage. Store the humidifier in a cool dry place.

## **Water Level Sensor**

To clean the water level sensor unscrew or snap off, depending on style, the plastic cap from the pin. Remove the water level sensor float and clean by wiping the parts with a soft damp cloth. Replace the parts by first putting the water float onto the pin and re-screwing the plastic cap onto pin.

### **TROUBLE SHOOTING**

**CAUTION: DO NOT attempt to repair the motor or nebulizer yourself. If the humidifier continues to not operate please call our service center (1-888-599-0922).**

<b>Problem</b>	<b>Solution</b>
<i>Humidifier power light is staying red and not turning green:  Humidifier is working than stops:</i>	<ul style="list-style-type: none"><li>▪ Ensure that the water tank cap is secured properly to water tank.</li><li>▪ Empty out water in water basin. Place filled water tank on to empty water basin.</li><li>▪ Clean Water Level Sensor.</li></ul>
<i>If humidifier does not work at all:</i>	<ul style="list-style-type: none"><li>▪ Ensure unit is properly plugged into a power outlet.</li><li>▪ Check that the Control Knob is turned to the ON position.</li><li>▪ If Power On indicator light does not come on, contact Crane service center.</li></ul>
<i>If there is a strange odor:</i>	<ul style="list-style-type: none"><li>▪ Clean the Water Tank with the water and vinegar solution and rinse with clean water.</li><li>▪ Leave the empty Water Tank open for some time (without the Water Tank Cap attached) in a cool place.</li></ul>
<i>The power light is green, but there is no mist being emitted:</i>	<ul style="list-style-type: none"><li>▪ Check that there is water in the Water Tank.</li><li>▪ Make sure that nothing blocks the Mist Output Slots.</li><li>▪ Check that the Fan Vent on the bottom of the humidifier is not blocked.</li><li>▪ Empty the humidifier and rinse the Water Basin with cool tap water and allow to dry for 15 to 30 minutes before resuming normal operation.</li><li>▪ Check for possible mineral deposits on the Water Level Sensor or the Nebulizer.</li></ul>
<i>White dust appears and settles outside the humidifier:</i>	<ul style="list-style-type: none"><li>▪ Area tap water may have too many minerals. Change to filtered or distilled water or purchase and add a Crane filter to the humidifier unit.</li></ul>

## **STORING YOUR HUMIDIFIER**

Allow the humidifier to dry completely before storing. Store the humidifier in a dry location. Do not place any heavy items on top of humidifier during storage as this may result in possible damage of the humidifier. Store the cord in a clean, dry location away from metal objects. Always check the plug before use to assure metal items have not become attached.

## **SERVICE CENTER**

If you have any questions with regard to the operation of this humidifier or are in need of a spare part, please contact our service center at:

### **Crane USA Inc.**

621 Route 83, Ste 202, Bensenville, Illinois 60106

Tel: 1-888-599-0992 (Business Hours: Monday-Friday 9:00 am-4:00 pm CT)

Website: <http://www.crane-usa.com>

**NOTE:** Spare Parts can also be purchased online at [www.crane-usa.com](http://www.crane-usa.com) under customer service, order spare parts.

## **ENVIRONMENTAL PROTECTION**



If the humidifier should no longer operate, please be sure to dispose of the unit in an environmentally friendly way by taking it into a public collection point. Please do not place broken humidifiers with your regular household waste.

## LIMITED WARRANTY

Thank you for purchasing a top quality **Crane** product. This Ultrasonic Humidifier was tested and meets our stringent quality standards. This product is warranted to be free from manufacturing defects under normal use and conditions for 1 year.

### NEED HELP?

**PLEASE DO NOT RETURN THIS PRODUCT TO THE STORE. CALL US FOR PROBLEMS AND QUESTIONS. WE CAN HELP.**

If you experience unsatisfactory operation, first refer to the troubleshooting section in the manual to ensure that it is not due to care or cleaning. Follow Care and Cleaning Instructions from manual. You can also visit [www.crane-usa.com](http://www.crane-usa.com) customer service for information.

If you have any questions or comments, please call our Crane Service Center 1-888-599-0992 or e-mail the Crane Service Center at: [customer-service@crane-usa.com](mailto:customer-service@crane-usa.com). Please specify the style and model number so our Customer Service Representative can advise you on how to correct the problem yourself or ask that you return the product for repair or replacement.

#### **WARRANTY REQUIRES A DATED PROOF OF PURCHASE.**

This Warranty is void if the defect is due to accidental damage, misuse, abuse, neglect, improper repair or alteration by unauthorized persons, or a failure to follow operating instructions provided with the product. This warranty does not apply to normal wear and tear or commercial use.

The Warranty is non-transferable and applies only to the original purchaser and does not extend to subsequent owners of the product. Liability under this warranty is limited to repair or replacement. In no event shall liability exceed the purchase price paid by the purchaser of the product. Under no circumstances shall there be liability for any loss - direct, indirect or incidental - special or consequential damage arising out of or in connection with the use of this product.

**This Warranty is valid only in the 48 contiguous states plus the District of Columbia** and excludes Puerto Rico and the Virgin Islands. This warranty is effective only if the product is purchased and operated in the United States of America.

This Warranty gives you specific legal rights. However you may have other rights that vary from state to state. Some states do not allow limitation on implied warranties or exclusion of consequential damages; therefore these restrictions may not apply to you.

Any instructions or Warranty included in this manual may be subject to change without notice. For the most up-to-date instructions and warranty information, please contact us or visit our website.

#### **Crane USA Inc.**

621 Route 83, Ste 202, Bensenville, Illinois 60106

Tel: 1-888-599-0992 (Business Hours: Mon-Fri 9:00 am-4:00 pm CT)

Website: <http://www.crane-usa.com>

**WARRANTY INFORMATION**

# WARRANTY CARD



## Ultrasonic Humidifier

This product is warranted to be free from manufacturing defects in original materials, including original parts and workmanship, for 1 year with dated proof of purchase. Any instructions or warranties included in this manual may be subject to change without notice. For the most up-to-date instructions and warranty information, please contact us or visit our website: [www.crane-usa.com](http://www.crane-usa.com).

**NOTE:** Spare Parts can also be purchased online at [www.crane-usa.com](http://www.crane-usa.com) under customer service, order spare parts.



**Please read limited Warranty conditions mentioned in this instruction manual!**

Please print clearly and fill in details below.

Send Warranty Card with product and dated purchase receipt or copy of receipt.

PLEASE DETACH THIS SECTION AND RETURN IT WITH YOUR PRODUCT

WARRANTY CARD

Customer Name	
Street Address	
City, State, Zip	
Phone (Day/Cell)	
E-mail address	
Model #/Style (Example: Frog)	
RA#	
Purchase Date	

Description of Defect:

--

**Crane USA Inc.**  
621 Route 83, Ste 202, Bensenville, Illinois 60106

Tel: 1-888-599-0992 (Business Hours: Mon-Fri 9:00 am-4:00 pm CT)  
Website: <http://www.crane-usa.com>



# ORDER FORM

## FOR CRANE ADORABLE HUMIDIFIER REPLACEMENT PARTS

**Price per Water Tank: \$24.00\***  
**Price per Water Tank Cap: \$10.00\***  
**Price per Water Tank Mist Lid: \$10.00\***  
*\*(includes shipping and handling)*

Please send a **CHECK or MONEY ORDER only** (no cash)  
Made payable to **CRANE USA.** to:

**Crane USA, Inc.**  
**621 Route 83, Ste 202**  
**Bensenville, IL 60106**

**Completely fill in information below and send with your Check or Money Order.**

*Please print clearly to avoid delays.*

<b>Name</b>	
<b>Street Address (No PO Boxes!)</b>	
<b>City</b>	
<b>State</b>	
<b>ZIP</b>	
<b>Phone #(Day &amp; Cell)</b>	
<b>E- Mail Address</b>	
<b>Model #/Style (Example: Frog)</b>	

**IMPORTANT:** Please circle your humidifier Central Body style. (*Look for Indicator Light above Control Knob for either a 1- or 2-light design.*)

**1-Light**

**2-Light**

<b>Water Tank</b> ____ @	<b>\$</b>
<b>Water Tank Cap</b> ____ @	<b>\$</b>
<b>Water Tank Mist Lid</b> ____ @	<b>\$</b>

<b>Total Enclosed</b>	<b>\$</b>
-----------------------	-----------



