

TROUBLE SHOOTING

| TROUBLE | POSSIBLE CAUSE | REMEDY |
|------------------|---|---|
| Clogged Nozzle | Ash is blocking nozzle end or nozzle is being held above the ash and ash is trying to go through all at once. | Place nozzle directly on firebrick and rub to move large particles out of the way and maintain air flow and to crush larger particles if necessary. |
| | Nozzle is backwards in hose. | Put smooth end in hose & crimped end out. |
| Poor Suction | Coated primary filter. | Clean primary filter see instructions on: "How To Clean Your Filter." |
| | Coated secondary filter. | Clean both primary and secondary filters. |
| Hose Becomes Hot | Clogged nozzle/hose. | See clogged nozzle. |
| | Cleaning TOO WARM of ash. | Let ash cool down. Do not use gloves to vacuum. |
| Dust Escaping | Hole in either filter. | Repair or replace filters. Small holes may be repaired with Silicone Rubber Sealant. |
| | Hose clamps are not tight enough. | Tighten hose clamps. |
| | Filters may have wrinkles or out of correct position. | Inspect filters and adjust them so they are smooth around the hose clamps. |
| | Pop rivets may start to leak air. | Caulk pop rivets from the inside of the unit. |

NOTE: Inspect filters before each use to insure that they are in good condition.

NOTE: EXCESSIVE OR ABUSIVE shaking of the filter support may result in tearing and/or premature wearing of either filter.

Crevice Tool - 4P19



Set
4P22

Brush Tool - 4P20



Pellet Stove Cleaning Tool

1P24

Filter Pkg. - 2F22

(Includes 1 Primary & 1 Secondary)

Wire Brush Tool - 14112 Round Wire Brush Tool - 14113

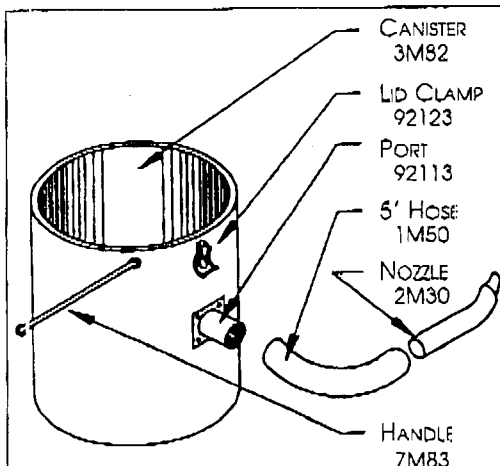

Model No. MU405 "COUGAR"
Model No. MU300 "CHEETAH II"

Received Time Dec. 28, 2007 12:11 PM No. 6874

