

3-Burner LP Gas Grill

WARNING

Improper installation, adjustment, alteration, service or maintenance can cause injury or property damage.

Read the installation, operation and maintenance instructions thoroughly before installing or servicing this equipment.

DANGER

Failure to follow these instructions could result in fire or explosion that could cause property damage, personal injury or death.

DANGER

DO NOT use gas grill for indoor cooking or heating. TOXIC fumes can accumulate and cause asphyxiation. **DO NOT** use in or on boats or recreational vehicles.

PROP 65 WARNING

Chemicals known to the state of California to cause cancer, birth defects or other reproductive harm are created by the combustion of propane.

WARNING

For Outdoor Use Only
(Outside any enclosure)

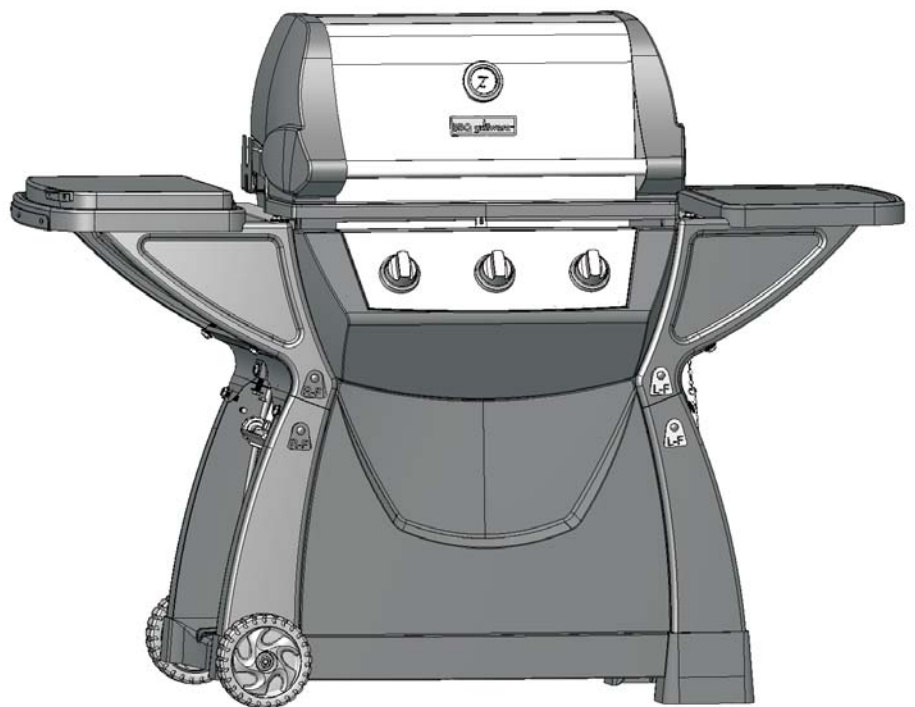

SAVE THESE INSTRUCTIONS FOR FUTURE REFERENCE. IF YOU ARE ASSEMBLING THIS UNIT FOR SOMEONE ELSE, GIVE THIS MANUAL TO HIM OR HER TO SAVE FOR FUTURE REFERENCE.

FOR CUSTOMER SERVICE, EMAIL TO SERVICE@PYROMAGICBBQ.COM OR CALL 1-877-885-8227,

6 A.M. – 5 P.M.(PST), MONDAY-FRIDAY.

FURTHER INFORMATION PLEASE VISIT OUR WEBSITE AT WWW.PYROMAGICBBQ.COM

GAS-FIRED



LISTED
20GX

Grill Operation 1-2-3

Before Grilling.

- Step 1 Keep your grill a safe distance away from your property.*
- Step 2 Always Perform a Leak Test. *
- Step 3 Keep children away from the grill.

During Grilling.

(To avoid tripping safety valves, please follow these instructions carefully!)

- Step 1 First open lid and turn gas valve on slowly.
- Step 2 Turn only one knob on at a time when lighting up the grill.
- Step 3 Use protective gloves when grill gets hot.

After Grilling.

- Step 1 Burn grill for 10-15 minutes to burn off food residues.
- Step 2 Wait until the grill is completely cooled before closing lid.
- Step 3 Clean up grease build-up and cover your grill.

* Please refer to the owner's manual for details.

WARNING

FOR YOUR SAFETY

1. DO NOT store or use gasoline or other flammable vapors and liquids within 25 feet of this or any other appliance.
2. When cooking with oil/grease, do not allow the oil/grease to exceed 350°F (177°C). Do not store or use extra cooking oil in the vicinity of this or any other appliance.
3. An LP cylinder not connected for use should NOT be stored within 10 feet of this or any other appliance.

WARNING

FOR YOUR SAFETY

If you smell gas:

1. Shut off gas to the appliance.
2. Extinguish any open flames.
3. Open lid.
4. If odor continues, immediately call your gas supplier or fire department.

Always read and understand the **WARNINGS** and **INSTRUCTIONS** that are contained in this manual before attempting to use this gas barbecue grill, to prevent possible bodily injury or property damage.

Always keep this manual in or near the grill, for convenient future reference.

Table of Contents

For Your Safety.....	3
Illustrated Parts List	5
Hardware List.....	6
Assembly Instructions.....	7
Operating Your Grill.....	15
LP Gas Supply Connection.....	15
Checking for Leaks.....	16
Lighting Your Grill.....	16
Excess Flow Safety Valve Reset Procedure....	17
Care and Maintenance.....	18
Award-Winning Barbecue Recipes.....	20
Troubleshooting.....	21
Warranty Program.....	22

For Your Safety

Dear Valued Customer,

Congratulations on your new barbecue grill purchase! You've made the right choice. In this manual, you will find assembly instructions, suggestions for grilling and helpful hints, as well as guidelines for the safe operation, proper care and use of your grill. Our expert staff strives to provide you with an easy to assemble product. Should you have any questions or problems with this product, please email to service@pyromagicbbq.com or call our customer service department at 1-877-885-8227

6:00 am - 5:00 pm (PST), Monday through Friday. Further information please visit our website at www.pyromagicbbq.com

NOTE: The use and installation of this product must conform to local codes. In the absence of local codes, use the National Fuel Gas Code, ANSI Z223.1/ NFPA54.

IMPORTANT NOTICE: READ ALL INSTRUCTIONS PRIOR TO ASSEMBLY AND USE

Safety First!

Read and understand all warnings and precautions prior to operating your grill.

WARNING

1. This grill is for outside use only. It should not be used in a building, garage or any other enclosed area.
2. The use of alcohol, prescription or non-prescription drugs may impair an individual's ability to properly assemble or safely operate this appliance.
3. Always open the grill lid carefully and slowly as heat and steam trapped within the grill could cause severe burns.
4. Always place your grill on a hard and level surface far away from combustible materials and structures. An asphalt or blacktop surface may not be acceptable for this purpose.
5. Do not leave a lit grill unattended.
6. Keep children and pets away from the grill at all times.
7. This is not a tabletop grill. Do not place this grill on any type of tabletop surface.
8. Do not use the grill in high winds.
9. This grill must be use with propane gas only (propane gas cylinder not included).
10. Do not attempt to attach this grill to the self-contained propane system of a camper, trailer, motor home or house.
11. Do not use charcoal or lighter fluid.
12. Do not use gasoline, kerosene or alcohol for lighting. The LP-gas supply cylinder must be constructed and marked in accordance with the specifications for propane gas cylinders of the U.S. Department of Transportation (DOT) CFR 49.
13. This outdoor gas appliance is not intended to be installed in or on recreation vehicles and/or boats.
14. Do not attempt to move the grill while it is lit.
15. Do not use the grill unless it is **COMPLETELY** assembled and all parts are securely fastened and tightened.
16. Keep combustible items and surfaces at least 24 inches away from the grill at all times. DO NOT use this gas grill or any gas product under any overhead enclosure or near any unprotected combustible constructions.
17. Do not use in an explosive atmosphere. Keep grill area clear and free from combustible materials, gasoline and other flammable vapors and liquids.
18. Do not attempt to use or assemble with missing or damaged parts. Contact customer service for a replacement.

CAUTION-Prevention of Burns

1. To avoid burns, do not touch metal parts of the grill until they have completely cooled for at least 45 minutes or unless you are wearing protective gear such as pot holders, gloves, BBQ mittens, etc.
2. Do not alter the grill in any manner.
3. Clean and inspect the hose before each use. If there is evidence of abrasion, wear, cuts or leaks, the hose must be replaced prior to operation. The replacement hose assembly should be in accordance with the manufacturer's specifications.
4. Move gas hoses as far away as possible from hot surfaces and dripping hot grease.
5. Never keep a filled gas container in a hot car or car trunk. Heat will cause the gas pressure to increase, which could open the relief valve and allow gas to escape.

Safe Locations For Use Of This Outdoor Grill

DANGER

Never use this outdoor grill inside any building, garage, shed or breezeway, or inside any boat, trailer or recreational vehicle, to prevent a possible fire and to prevent the possibility of carbon monoxide poisoning or asphyxiation.

WARNINGS

Do not use this appliance under overhead combustible surface or covered area (e.g., awnings, umbrellas, porches or gazebos).

Always confirm that this grill is not positioned under the overhang of a house, a garage or other structure before lighting it. An overhang will serve to deflect flare-ups and radiated heat into the structure itself, which could result in a fire.

Always confirm that this grill is positioned more than 24 inches (61 cm) away from any combustible materials or surface before lighting it, and that no gasoline or other volatile substances are stored in the vicinity of this grill. (As the fig. shown on right).

The temperature of a grease fire or of the radiated heat might otherwise be sufficient to ignite nearby combustible or volatile substances.

Always locate this grill where there will be ample combustion and ventilation air, but never position it in the direct path of a strong wind.

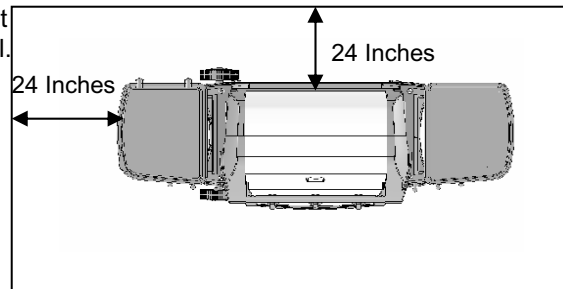

Never allow the grill to operate while unattended, to prevent uncontrolled grease fires from erupting.

Never attempt to move this grill while it is in operation or while it is still hot, to prevent possible personal injury.

Never store or use gasoline or other flammable or volatile substances in the vicinity of this grill or in the vicinity of any other heating-generating appliance, because of the danger of starting a fire.

Always confirm that the installation of this grill conforms with the requirements of all local codes or, in the absence of applicable local codes, with either the National Fuel Gas Code, ANSI Z223.1 NFPA 54 or CAN/CGA-B149.2, Propane Installation Code.

DANGER – Gas Safety

Liquid propane (LP) gas is flammable and hazardous if handled improperly. Become aware of its characteristics before using any propane product.

- Propane Characteristics: Flammable, explosive under pressure, heavier than air and settles in pools in low areas.
- In its natural state, propane has no odor. For your safety, an odorant has been added.
- Contact with propane could cause freeze burns to the skin.
- This grill is shipped from the factory for propane gas use only.
- Never use a propane cylinder with a damaged body, valve, collar or footing.
- Dented or rusted propane cylinders may be hazardous and should be checked by your propane gas supplier.

CAUTION

- It is essential to keep the grill's valve compartment, burners and circulating air passages clean.
- Inspect the grill before each use.

GENERAL INFORMATION

1. A propane gas cylinder is required for operation.
2. This gas grill is NOT intended for commercial use.

Illustrated Parts List

1. Leg R-F -----1pc 	2. Leg L-F -----1pc 	3. Leg L-B -----1pc 	4. Leg R-B -----1pc 
5. Right Foot-----1pc 	6. Left Foot-----1pc 	7. Wheel-----2 pcs 	8. Axle-----1pc 
9. Cart Front Panel-----1pc 	10. Top Cart L-F-----1pc 	11. Top Cart L-B-----1pc 	12. Top Cart R-F -----1pc 
13. Top Cart R-B -----1pc 	14. Control Panel -----1pc 	15. Cart Beam-----2pcs 	16. Back Beam-----1pc 
17. Tank Hook-----1pc 	18. Grill Body Assembly-----1pc 	19. Right Side Shelf-----1pc 	20. Left Side Shelf-----1pc 
21. Side Burner Grate -----1pc 	22. Heat Plate-----3pcs 	23. Cooking Grid-----2pcs 	24. Warming Rack-Body-----1pc 
25. Warming Rack- Lid-----1pc 	26. Cup Support-----1pc 	27. Grease Cup-----1pc 	

Hardware List

A	 <p>M6 X 16mm Bolt</p>	29pcs (2pcs spare included)	B	 <p>M4 X 10mm Bolt</p>	2pcs
C	 <p>Side Burner Knob</p>	1pc	D	 <p>Axle Nut</p>	2pcs
E	 <p>Phillips Head Screwdriver</p>	1pc	F	 <p>Wrench</p>	2pcs
G	 <p>M10 Washer</p>	2pcs	H	 <p>Collar</p>	1pc

**Hardware listed above is not scaled to exact size
(A screwdriver is included for your convenience.)**

Assembly Instructions

Remove all contents from the carton packaging. Make sure all parts are present before attempting assembly. Once the grill is fully assembled, go back check and make certain all the bolts are tighten. Tighten again by the screwdriver provided if it is necessary.

Estimated Assembly Time: It will takes less than 40 minutes to assembly the grill

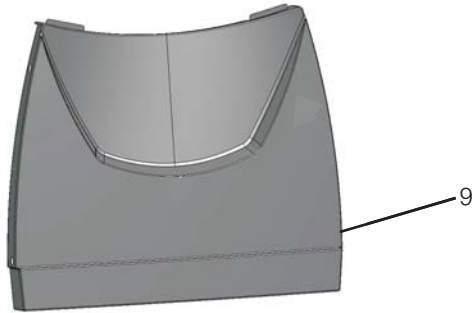

Step 1

Align the holes at the cart front panel (9) with the holes on the leg R-F (1).
Screw a M6x16mm bolt (A) into each pre-drilled hole and tighten by hand until secure.
Repeat the procedure for the leg L-F(2).
Go back and tighten by the screwdriver provided.

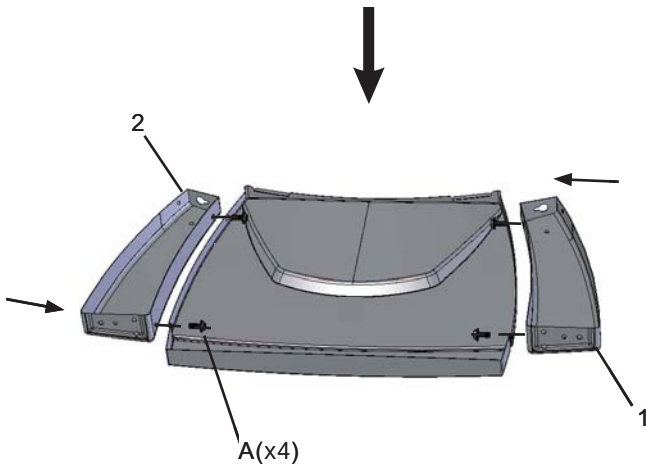

Step 2

Align the holes on the right foot (5) with the holes on the leg R-F(1) and the leg R-B (4) respectively .
Screw a M6x16mm bolt (A) into each pre-drilled hole and tighten by hand until secure.
Align the holes on the left foot (6) with the holes on the leg L-F(2) and the leg L-B (3) respectively .
Screw a M6x16mm bolt (A) into each pre-drilled hole and tighten by hand until secure.
Go back and tighten by the screwdriver provided.

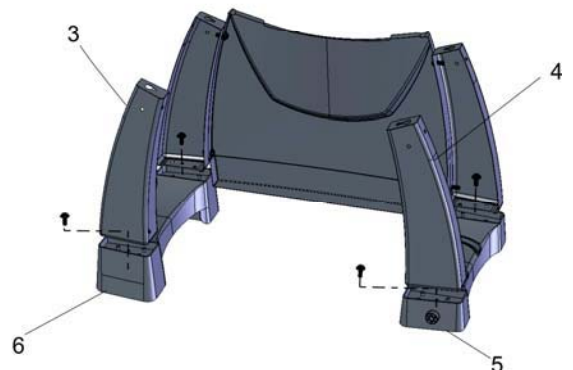
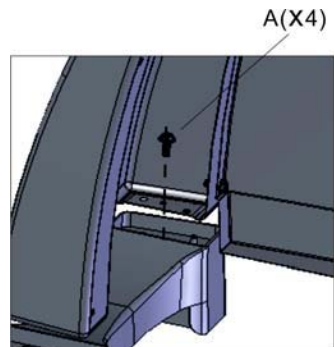

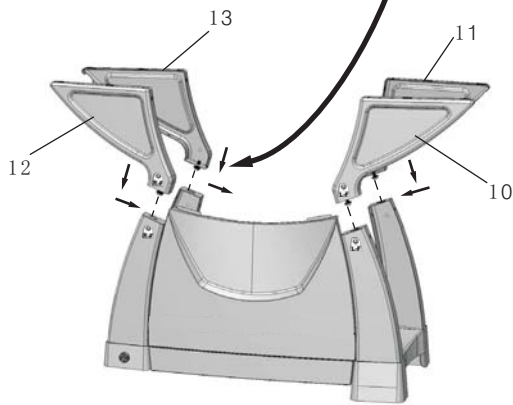
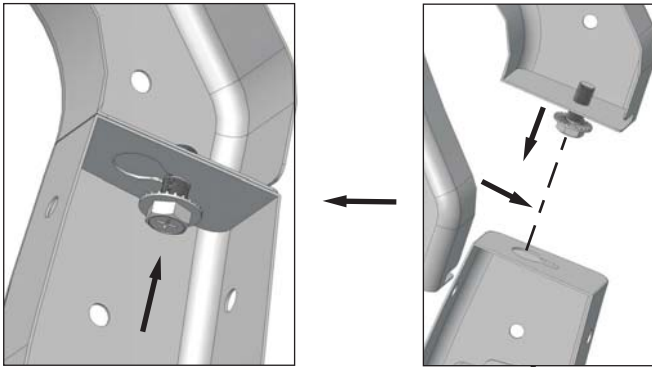

Step 3

Align the holes on the top cart R-F(12) with the holes on the leg R-F(1). Screw a M6x16mm bolt (A) into a pre-drilled hole. Align the holes on the top cart R-B (13) with the holes on the leg R-B (4). Screw a M6x16mm bolt (A) into a pre-drilled hole. Align the holes on top cart L-F(10) with the holes on leg L-F(2). Screw a M6x16mm bolt (A) into a pre-drilled hole.

Align the holes on the top cart L-B (11) with the holes on leg L-B (3), Screw a M6x16mm bolt (A) into a pre-drilled hole.

Tighten all bolts by hand until secure. Go back and tighten by the screwdriver provided.

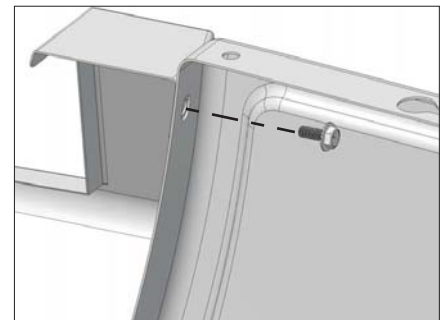

Step 4

Align the hole on control panel (14) with a hole on the top cart R-F(12). Screw a M6x16mm bolt (A) into a pre-drilled hole. Align the hole on control panel (14) with a hole on top cart L-F(10). Screw a M6x16mm bolt (A) into a pre-drilled hole. Tighten by hand until secure. Go back and tighten by the screwdriver provided.

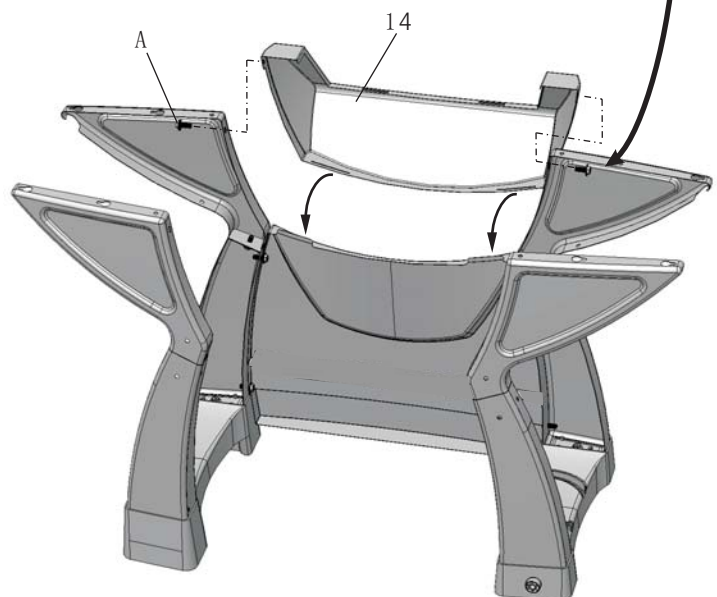

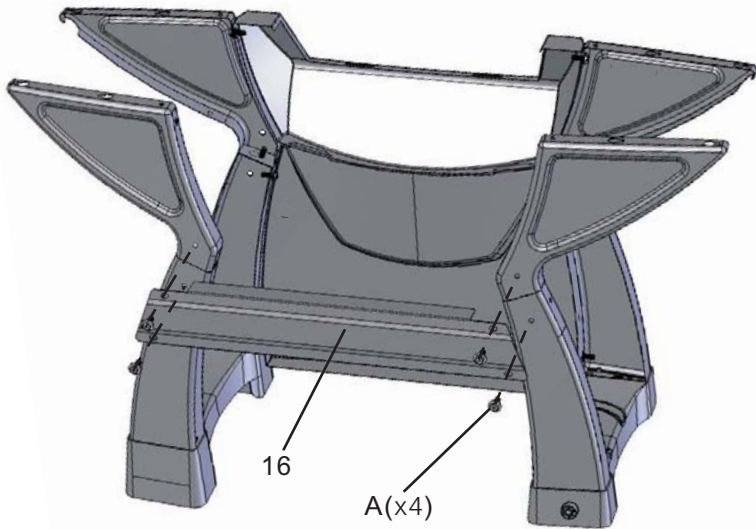

Step 5

Align the holes on back beam (16) with the holes on leg L-B (3). Screw a M6x16mm bolt (A) into each pre-drilled hole.

Align the holes on back beam (16) with the holes on leg R-B (4), screwing a M6x16mm bolt (A) into each pre-drilled hole.

Tighten all bolts by hand until secure.

Go back and tighten by the screwdriver provided.

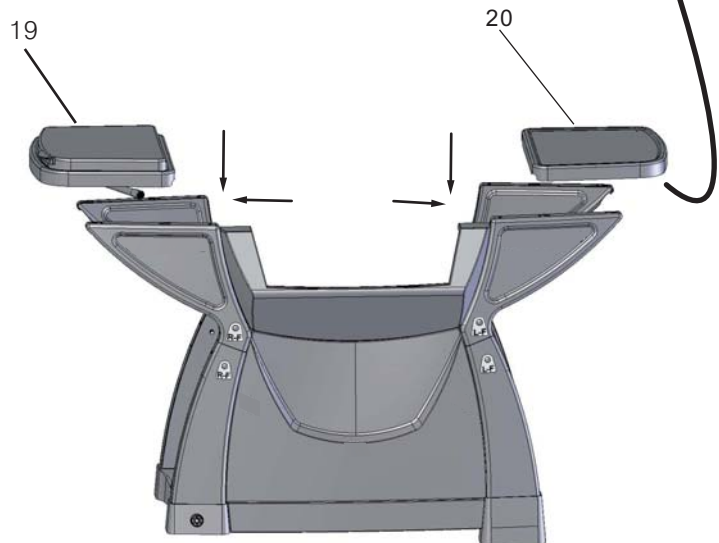
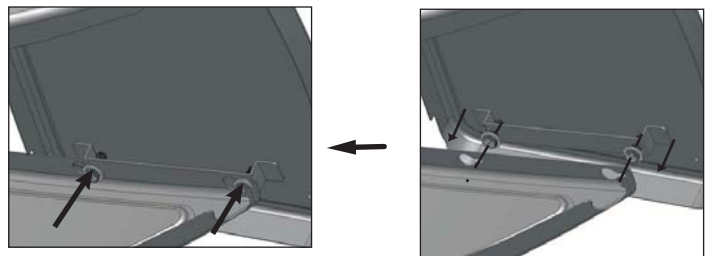

Step 6

Align the pre-assembled adjustable screw on the left side shelf (20) with the holes on the top cart L-F(10) and the top cart L-B (11) respectively.

Move the left side shelf to the direction of the narrow end of the holes on the top cart L-F and top cart L-B.

Tighten the pre-assembled adjustable screw.

Repeat the same procedure for the right side shelf (19).

Tighten all bolts by hand until secure.

Go back and tighten by the screwdriver provided

Step 7

Insert the axle (8) into the hole of the right foot.

Put a wheel (7) and a M10 (G) washer on each end of the axle.

NOTE: protruding side of each wheel must face the surface of grill leg.

Tighten each axle nut (D) toward the wheel, make certain each axle nut should be flat with each end of axle.

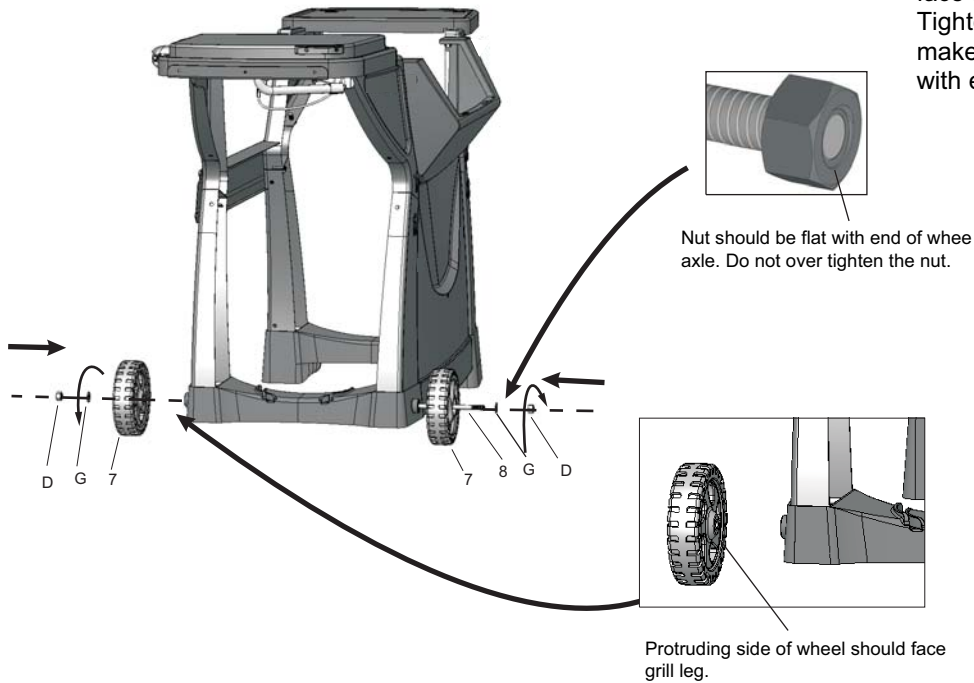

Step 8

Put grill body assembly (18) upon cart assembly. Align the holes on both side of grill body with the holes on both side cart, make certain stainless steel face panel flat ends fully insert into each hole in the control panel.

Screw a M6x16mm bolt (A) into each pre-drilled hole. Tighten by screwdriver until secure.

Tighten the bolts by the screwdriver provided.

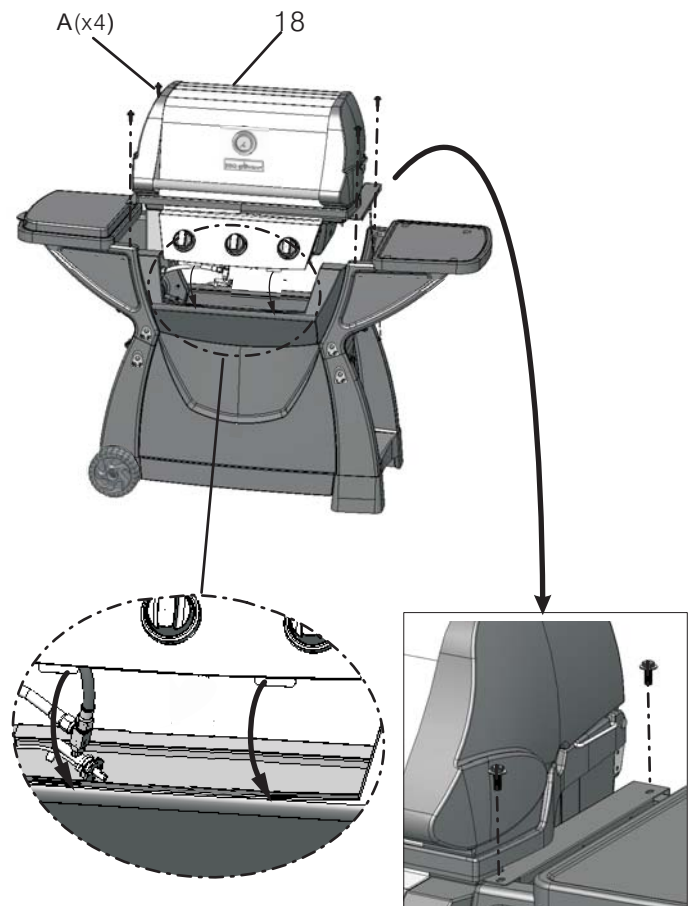

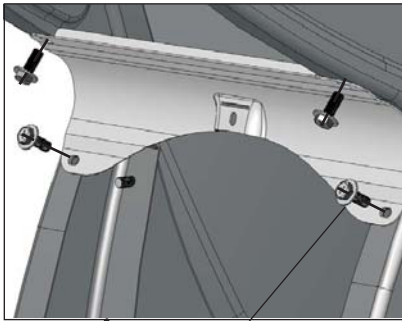

A(X8)

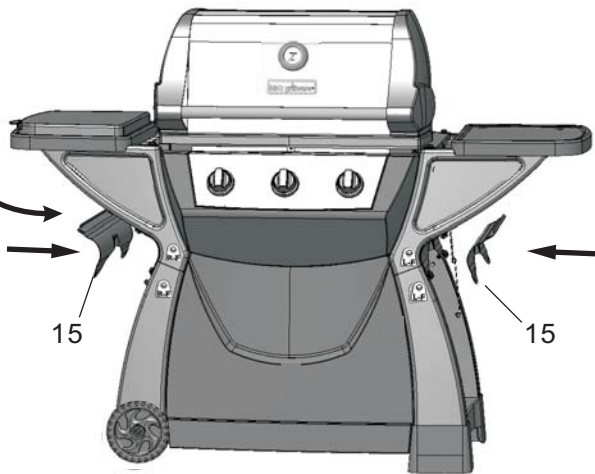

Step 9

Align the holes on the cart beam (15) with the holes on the left cart
Screw a M6x16mm bolt (A) into each pre-drilled hole and tighten by hand until secure.
Repeat the procedure for the right cart.
Go back and tighten by the screwdriver provided.

Step 10

Align the hole on tank hook (17) with the holes on the right cart beam.
Screw a M6x16mm bolt (A) into the pre-drilled hole.
Tighten the bolt by the screwdriver provided.

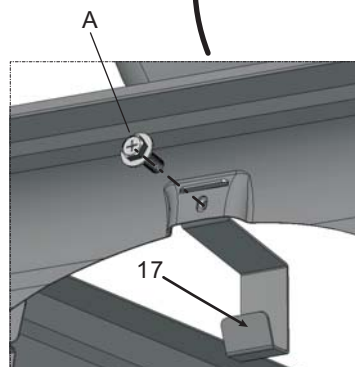
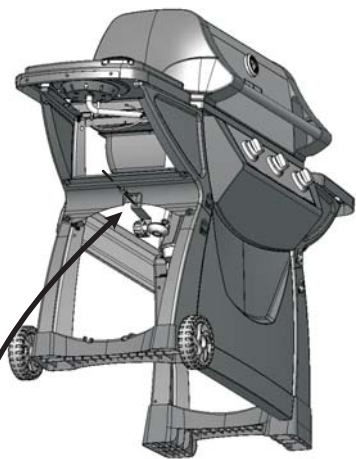

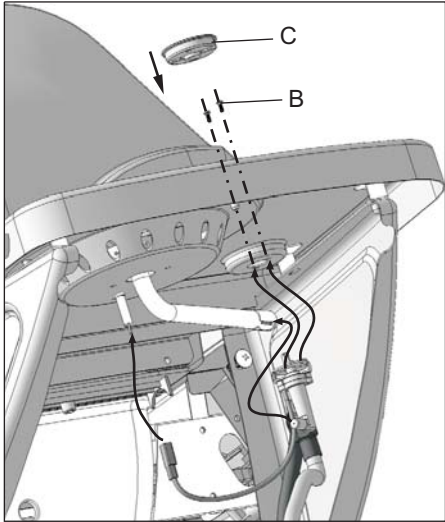

Step 11

Open the side burner lid. Insert side burner valve into the venturi tube on the side burner..
 Align the holes on side burner valve with the holes on the side burner knob seat.
 Screw a M4x10mm bolt (B) into each pre-drilled hole.
 Tighten the bolts by the screwdriver provide.
 Insert the side burner knob (C) into side valve shaft.
 Connect the ignition cable with the electrode.
 Make certain the connection is secure.

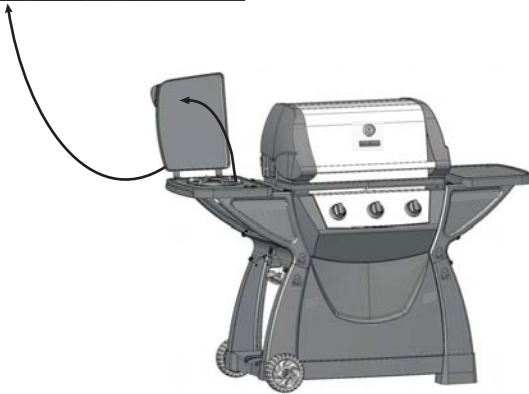

Step 12

Place the heat plates (22) on top of the burners in the grill.
 Place the cooking grids (23) on the grill surface.
 Open the side burner lid, and place the side burner grate (21) on top of the side burner.

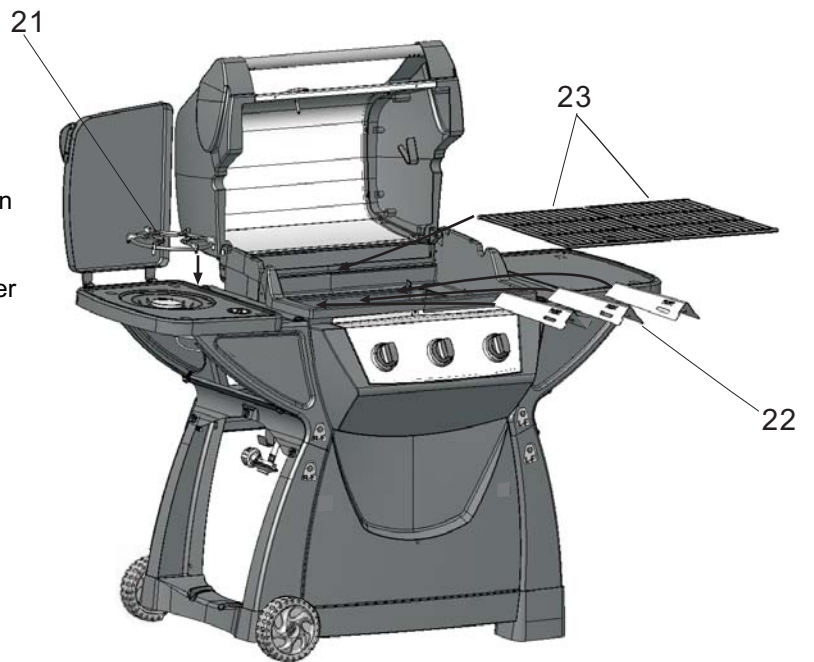

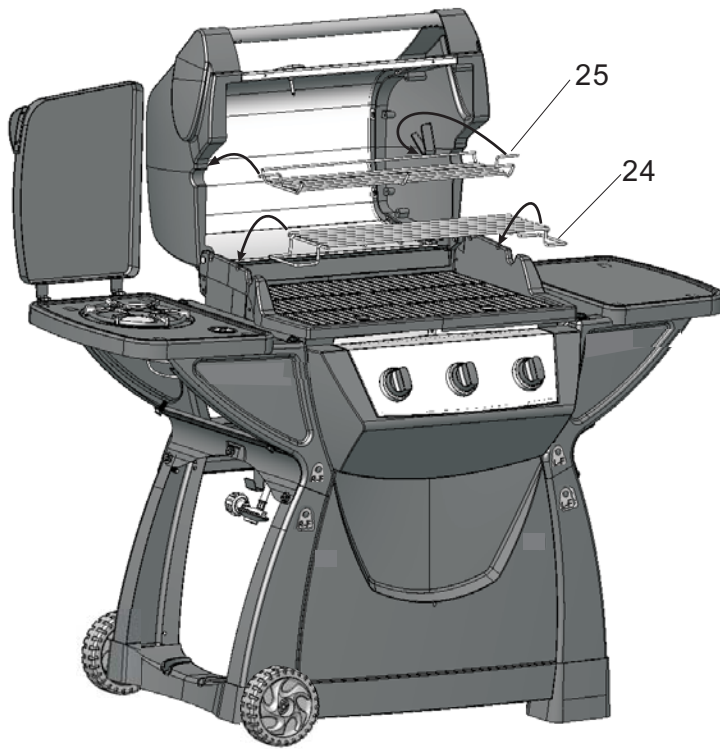

Step 13

Insert the warming rack–lid (25) on the hook on the both side of the grill lid.
Put the warming rack-body (24) on top of the grill body above the cooking grids.
Make certain the two racks are on a secure position.

Step 14

Hook both ends of the cup support (26) on the holes of the grease pan.
Place the grease cup (27) on the cup support.

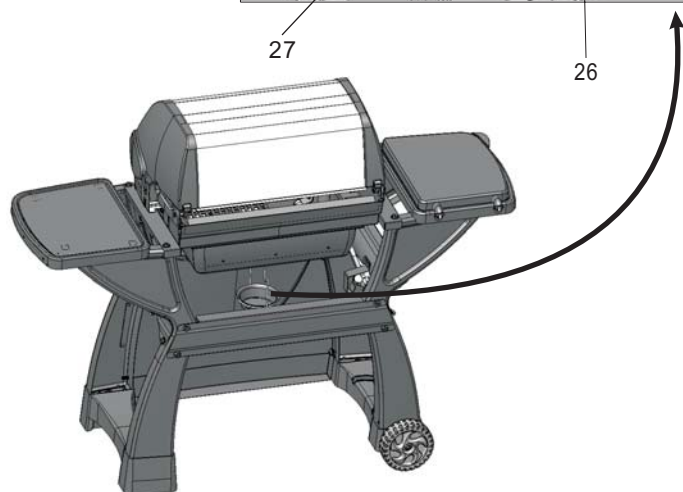
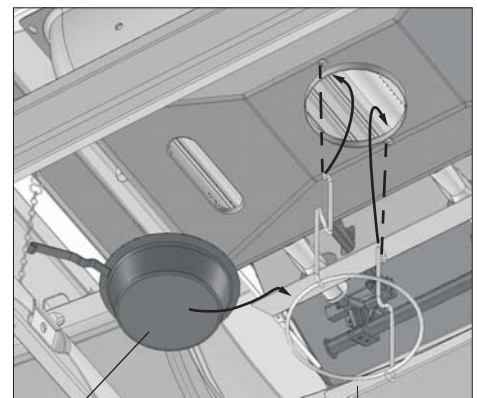

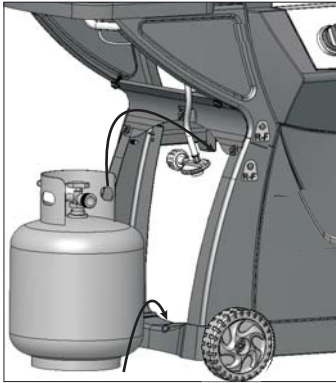

Step 15

Screw the regulator with gas hose into cylinder valve. (Gas cylinder not included). Make certain the regulator is connected secure.
 *Refer to LP Gas Supply Connection in the manual for important safety information.

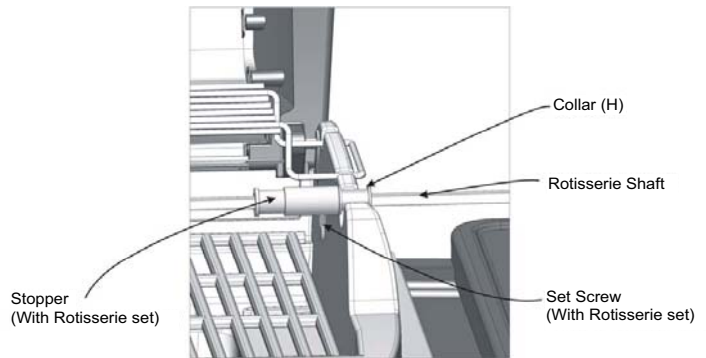
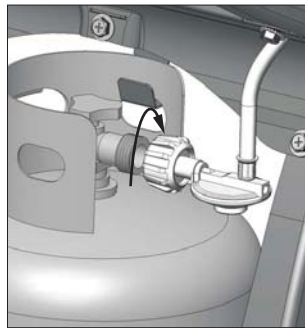

Step 16

Collar (H) In Hardware Pack Assembly.
 (When operating with rotisserie set)
 (1): Insert the collar (H) into rotisserie shaft.
 (2): Place the collar on the groove of the left side wall of grill body.
 (3): Push the stopper to contact with the collar and tighten the set screw.

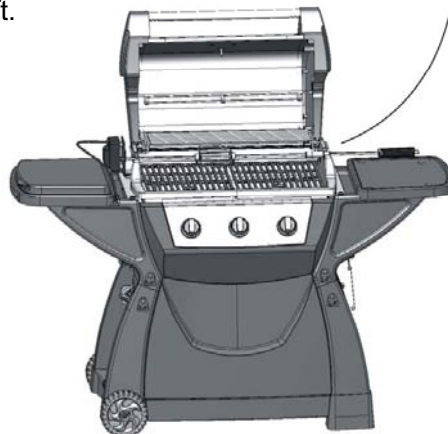

Fully Assembled View

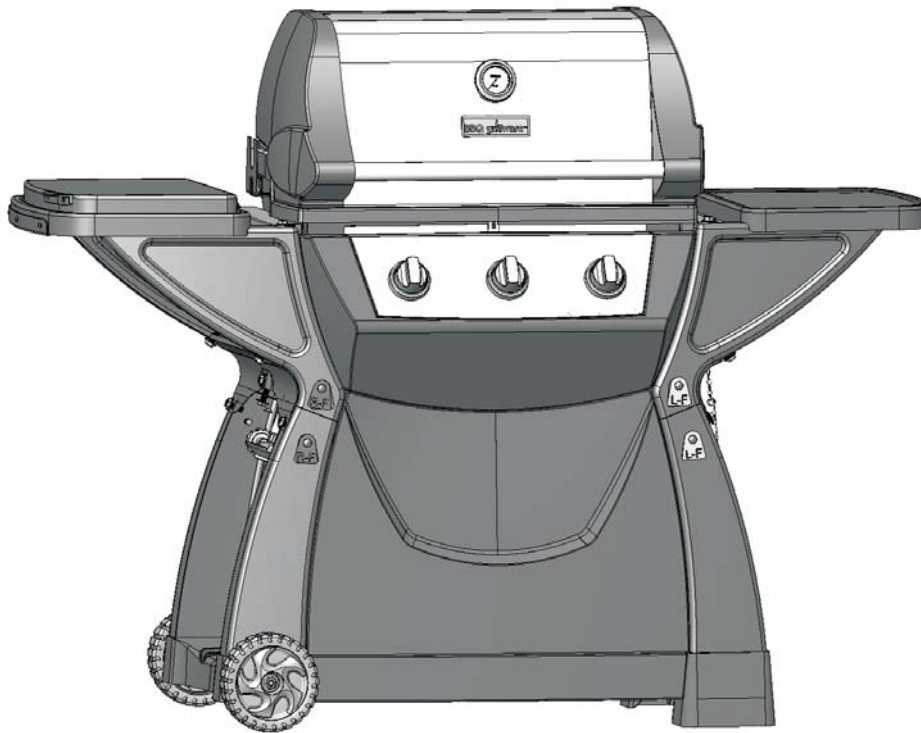

Operating Your Grill

CAUTION:

Use only the regulator provided. If a replacement is necessary, call our customer service center. The use of unauthorized parts can create an unsafe condition and environment.

The propane gas supply cylinder used must be constructed and marked in accordance with the *Specifications for Propane Gas Cylinders* of the U.S. Department of Transportation (DOT). Only cylinders with a listed overfill prevention device (OPD) and marked "propane" may be used. Cylinders with an OPD will have valve handles with three "lobes" (prongs).

The pressure regulator and hose assembly supplied with the outdoor cooking gas appliance must be used. Replacement pressure regulators and hose assembly must be those specified by the outdoor cooking gas appliance manufacturer. Only use 20 pound cylinders equipped with a cylinder connection device compatible with the connection for outdoor cooking appliances. The cylinder must include a collar to protect the cylinder valve. The gas cylinder should not be dropped or handled roughly. If the appliance is not in use, the gas cylinder must be disconnected.

Storage of the appliance indoors is permissible **ONLY** if the cylinder is disconnected and removed from the appliance. Cylinders must be stored outdoors and out of the reach of children. Cylinder must not be stored in a building, garage or other enclosed area. Your cylinder must never be stored where temperatures can reach over 125F.

Before connecting, make sure there is no debris caught in the head of the gas cylinder, regulator valve or in the head of the burner and burner ports. Connect regulator valve and hand tighten firmly. Disconnect the propane cylinder from the regulator valve when the grill is not in use. **DO NOT** obstruct the flow of combustion air or ventilation air to the grill. The propane cylinder must be arranged for vapor withdrawal and equipped with a listed overfill prevention device (OPD).

Danger: A fire causing death or serious injury may occur if the following is not followed exactly:

Never store or use gasoline or other volatile substance in the vicinity of this grill.

Never store a spare propane cylinder in the vicinity of this grill, or in the vicinity of another potential heat source.

Never fill the propane cylinder beyond 80% full.

LP (Propane) Gas Supply Connection

1. Always place the propane cylinder on the tank brackets located on the right side of the cart.
2. Always confirm that all burner control knobs are in the OFF position before activating the gas supply.
3. Before connection, be sure that there is no debris caught in the head of the gas cylinder, head of the regulator valve, or in the head of the burner and burner ports.
4. Always connect the gas supply regulators as follows:
Insert the nipple of the valve coupling into the tank valve and tighten the connection collar by turning it clockwise with one hand while holding the regulator with the other.
(As the fig. shown on right)
5. Disconnect the propane cylinder from the regulator valve when the grill is not in use.
6. Do not obstruct the flow of combustion air and ventilation air to the grill.



DANGER

To prevent fire or explosion hazard when testing for a leak:

1. Always perform the "leak test" on page 16 before lighting the grill and each time the cylinder is connected for use.
2. Do not smoke or allow other sources of ignition in the area while conducting a leak test.
3. Conduct the leak test outdoors in a well-ventilated area.
4. Do not use matches, lighters or a flame to check for leaks.
5. Do not use grill until all leaks have been sopped, if you are unable to stop a leak, disconnect the propane supply, call for gas appliance service or your local propane gas supplier.

Checking for Leaks

1. Make a 2-3 oz. of leak solution by mixing one part liquid dishwashing soap with three parts water.
2. Make sure control knobs are in the "OFF" position.
3. Spray some solution on the tank valve up to the regulator connection.
(As the fig. shown on right).
4. Inspect the solution at the connections, looking for bubbles. If no bubbles appear, the connection is secure.
5. If bubbles appear, you have a leak. Go to step 6.
6. Disconnect the regulator from the tank and reconnect, make sure the connection is secure.
7. Retest with solution.
8. If you continue to see bubbles, replace the cylinder.



Lighting Your Grill

Danger: Failure to open lid while igniting the barbecue's burners or not waiting 5 minutes to allow gas to clear if the barbecue does not light, may result in an explosion, which could cause serious bodily injury or death.

WARNING: Never stand with your head directly over the grill when preparing to light the main burners, to prevent possible bodily injury.

Main Burner

1. Open lid while lighting burners.
WARNING: Attempting to light the burner with the lid closed may cause an explosion. Make sure there are no obstructions of airflow to the gas unit. Spiders and insects can nest and clog the burner/venturi tube at the orifice. A clogged burner tube can lead to a fire beneath the appliance.
2. All valves must be in the "OFF" position.
3. Open cylinder valve.
4. Ignite only the burners you wish to use, using the same method for each:
Push desired burner valve knob and rotate slowly about 1/4 counter-clockwise until a click is heard. The burner should light. If the burner does not light, return the valve knob to the "OFF" position immediately. Wait five minutes for the gas to clear and repeat the procedure. After burner is lit, repeat the procedure with any other burner desired.
5. Adjust valve knob(s) to desired cooking temperature.

Using the Lighting Stick to Light the Main Burners

1. Remove the cooking grid from the burner you wish to light.
2. Insert a match into the end of lighting stick. Light the match.
3. Once lit, place the flame through the hole on grill body to reach the burner ports.
(As the fig. shown on right side).
4. Press the valve knob and rotate it counter clockwise to the "HIGH" position. The burner should light immediately. To light up other burners, repeat the same procedure for the adjacent burner and continue in sequence until all desired burners are lit.
5. Replace cooking grid and adjust burners to the desired cooking temperature.

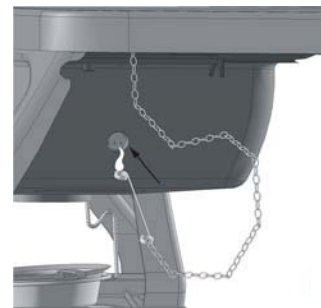

Precautions

1. After lighting, please observe the burner flame. Make sure all burner ports are lit.
2. If the burner flame goes out during operation, immediately turn the gas "OFF". Open lid to let the gas clear for at least 5 minutes before re-lighting.
3. Before cooking on the grill for the first time, operate the grill for approximately 15 minutes with the lid closed and the gas turned on "HIGH". This will "heat clean" the internal parts, dissipate odor from the manufacturing process and painted finish.
4. Clean the grill after each use. DO NOT use abrasive or flammable cleaners. this may damage parts of the grill and cause a fire.

Side Burner

1. Open lid while lighting the burner. Lid must remain open while burner is lit.
2. Valve must be in the "OFF" position.
3. Open cylinder valve.
4. Push side burner knob fully and rotate it slowly about 1/4 counter-clockwise until a click is heard. The burner should light. If the burner does not light, turn the knob to the "OFF" position immediately. Wait five minutes for the gas to clear and repeat the procedure.
5. Adjust valve knob to the desired cooking temperature

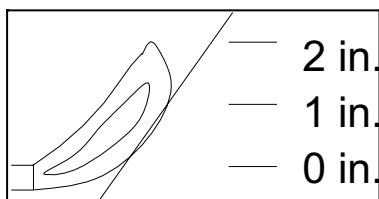

**Observe flame height when lit:
Flame should be a blue/yellow color between 1 to 2 inches high.**

Confirm that the burner is properly lit and that the flame pattern is as desired,(see fig. A,B and C below for the proper flame patterns).If the flame pattern is other than normal, consult the troubleshooting guide on page 21 for corrective action.

FIG. A

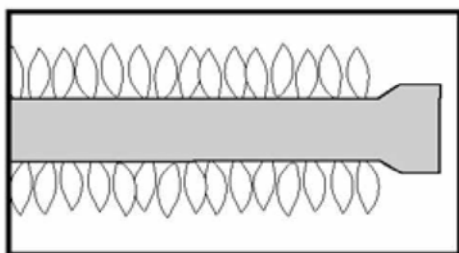

Normal: Soft blue flames with yellow tips between 1 inch - 2 inches high.

FIG. B

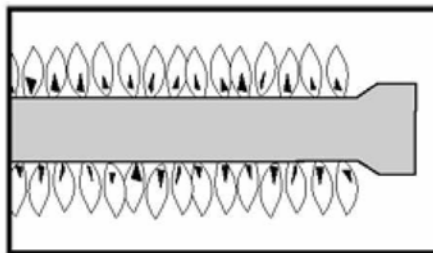

Out of adjustment: Noisy hard blue flames – too much air.

FIG. C

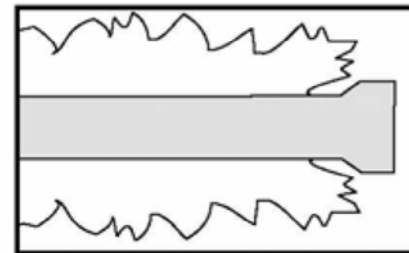

Poor combustion: Wavy, yellow flames- too little air.

Excess Flow Safety Valve Reset Procedure

The new regulators are equipped with a safety device that restricts the gas flow in the event of a gas leak. However, unsafe practices of grill operation could activate the safety device without having a gas leak.

A sudden shut off of the gas flow typically occurs if you open the LP tank valve rapidly, or if one or more of the burner control knobs is in an open position when opening the LP tank valve.

This procedure is effective with all LP Tank sizes as well as Natural Gas. When performing the procedure on a Natural Gas model, simply substitute "Natural Gas valve" for "LP Tank".

To ensure the procedure is safely and is successfully performed, please carefully follow the instructions below.

1. Close the LP tank valve.
2. Turn all burner control knobs to the OFF position.
3. Disconnect the regulator from the LP tank.
4. Open the lid of the grill.
5. Turn burner control knobs to HIGH.
6. **Wait at least 1 minute.**
7. Turn burner control knobs OFF.
8. **Wait for at least 5 minutes.**
9. Re-connect the regulator to the LP tank.
10. **SLOWLY** turn the LP tank valve at ¼ turn at a time and have the valve all the way open.
11. **With the lid open, For BBQ with ignition button: ONLY** turn on **ONE** front burner control knob to the HIGH position. Ignite the grill by pushing the ignition button. **For BBQ with an automatic ignition:** Push down the control knob you want to light, turn counter clock wise until you hear the ignition click.
12. After the first front burner is lit, turn on the other control knob(s) to the HIGH position. ****If you have more than two burners, ONLY turn them on ONE AT A TIME.**
13. When all front burners are lit, close the BBQ lid
14. Wait for 10-15 minutes, the temperature should reach 400 – 450 F°

Flare-ups

"Flare-ups" sometimes occur when food drippings fall onto the hot heat distribution plate or burners and ignite. Some flaring is normal and desirable, as it helps impart the unique flavors associated with grilled foods. Controlling the intensity of the flare-ups is necessary, however, in order to avoid burned or unevenly cooked foods and to prevent the possibility of accidental fire.

WARNING: Always monitor the grill closely when cooking and turn the flame level down (LOW) or OFF, if flare-ups intensify

Shutting Off Burners

1. Always turn the valve knob(s) clockwise to the "HIGH" position, then press and turn it to "OFF". Never force the knob without pressing it. This could damage the valve.
2. Promptly turn the gas supply to the "OFF" position at the propane cylinder.
3. Close the lid of the grill.

IMPORTANT

Always allow to completely cool off before covering your grill to prevent corrosion from condensation

Care and Maintenance

Caution: All cleaning and maintenance should be done when the grill is cool, with the fuel supply turned off at the control dial and the propane cylinder disconnected. DO NOT clean any grill part in a self-cleaning oven. The extreme heat will damage the finish.

Cleaning

Burning off the grill after every use (approx. 15 minutes) will keep excessive food residue from building up.

Recommended cleaning materials -

Mild dishwashing liquid detergent	Hot water
Nylon cleaning pad	Wire brush
Paper clip	Putty knife/scrapper

Compressed air

DO NOT use cleaners that contain acid, mineral spirits or xylene.

Outside surfaces

Use a mild dishwashing detergent and hot water solution to clean. Rinse thoroughly with water.

Inside surface

If the inside surface of the grill lid has the appearance of peeling paint, baked on grease has turned to carbon and is flaking off. Clean thoroughly with a strong solution of detergent and hot water. Rinse with water and allow it to completely dry.

Interior of grill bottom – Remove residue using brush, scraper and/or cleaning pad. Wash with a dishwashing detergent and hot water solution. Rinse with water and let dry.

Cooking Grids – The porcelain grates have a glass-like composition that should be handled with care. Use a mild dishwashing detergent or baking soda and hot water solution. Non-abrasive scouring powder can be used on stubborn stains. Rinse with water.

Heat Plates – Clean residue with wire brush and wash with soapy water. Rinse with water.

Grease Cup – Periodically empty the grease cup and clean with a dishwashing detergent and hot water solution.

Cleaning the Burner Assembly

1. Turn gas off at the control knobs and propane tank.
2. Remove cooking grids and heat plate.
3. Remove grease cup.
4. Remove burner by unscrewing nut from beneath burner “foot” using a screwdriver and pliers.
5. Lift burner up and away from the gas valve orifice.
6. Clean inlet (venturi) of burner with small bottle brush or compressed air.
7. Remove all food residue and dirt on outside of burner surface.
8. Clean any clogged ports with a stiff wire (such as an opened paper clip).
9. Inspect burner for damage (cracks or holes). If damage is found, replace with a new burner. Reinstall burner. Check to ensure the gas valve orifices are correctly positioned, pointing straight into burner inlet (venturi). Also, check position of spark electrode.

Award-Winning Barbecue Recipes

Never-fail Barbecue Sauce

Ingredients:

¼ cup	Finely chopped onion
2 tablespoons	Butter or margarine
¼ cup	Brown sugar, firmly packed
1 tablespoon	Worcestershire sauce
¼ teaspoon	Hot sauce
1	Garlic clove, finely chopped
1 cup	Catsup
¼ cup	Lemon juice
1 teaspoon	Prepared mustard

Prepare:

Cook onion and garlic in margarine until tender. Add remaining ingredients and bring to a boil. Simmer uncovered 15 to 20 minutes. Refrigerate leftovers after use.

Mamma's Marinated Chicken

Ingredients:

¼ cup	Dijon mustard
2 tablespoons	Fresh lemon juice
1 ½ teaspoons	Worcestershire sauce
½ teaspoon	Dried tarragon
¼ teaspoon	Freshly ground black pepper
4	Boneless, skinless chicken breast halve

Prepare:

Combine ingredients, mixing well. Marinade chicken for several hours. Grill uncovered, over medium heat, for 10 to 15 minutes. Chicken is done when juices run clear.

Barbecued Honey Steak

Ingredients:

5 pounds	Beef sirloin steak
2 tablespoons	Red pepper -- crushed
1 teaspoon	Black pepper
2	Garlic cloves -- crushed
1 large	Onion
1 cup	Honey

Prepare:

Combine all ingredients and marinate steak for 7-8 hours. Remove meat from marinade and grill over very high heat to desired doneness. Heat leftover marinade to a boil and pour over grilled steak to serve.

Hardcore Grilled Trout

Ingredients:

¼ cup	Lemon or lime juice
2 tablespoons	Melted butter
2 tablespoons	Vegetable oil
2 tablespoons	Chopped parsley
1 tablespoon	Hot sauce
½ teaspoon	Ground ginger
½ teaspoon	Salt
4 brook trout -- about 1 pound each	

Prepare:

Combine lemon juice, margarine, oil, parsley, hot sauce, ginger and salt. Mix well. Pierce skin of fish in several places. Roll fish in juice mixture to coat inside and out. Cover and refrigerate 30 minutes to 1 hour, turning occasionally. Remove fish from marinade. Place fish on grill; brush fish with marinade while grilling. Cook over high heat for 5 minutes. Turn and brush with marinade. Cook 5 minutes longer. Fish is done when it flakes easily with fork.

Grilled Veggies

Ingredients:

¾ cup	Olive oil
¼ cup	Red wine vinegar
1 teaspoon	Fresh rosemary
1 teaspoon	Fresh thyme leaves
1 teaspoon	Fresh basil, chopped
1 teaspoon	Fresh oregano, chopped
1 tablespoon	Minced garlic
½ teaspoon	Salt
½ teaspoon	Ground black pepper
2 pounds assorted vegetables, chopped or whole according to taste.	

Prepare

Combine all ingredients in a small bowl. Marinade vegetables with sauce. Cover and refrigerate for 2 hrs. Grill vegetables over medium heat until tender, brushing them with marinade while they cook. Cooking times will vary according to the vegetables chosen.

Troubleshooting

Problem	Possible Cause	Solution
Burner will not light using knobs.	Wires or electrode covered with cooking residue.	Clean wire and/or electrode with rubbing alcohol.
	Electrode and burners are wet.	Wipe dry with cloth.
	Electrode cracked or its sparks at the crack.	Replace electrode.
	Wire is loosen or disconnected.	Reconnect wire or replace electrode/wire assembly.
Burner will not light with match.	No gas flow.	Call your natural gas company
	Obstruction of gas flow.	Clear burner tubes. Check for bent or kinked hose.
	Disconnection of burner to valve.	Reconnect burner and valve.
	Spider webs or insect nest in venturi tube.	Clean venturi tube.
Sudden drop in gas flow.	Burner ports clogged or blocked.	Clean burner ports.
	Out of gas.	Call your natural gas company.
Irregular flame pattern, flame does not run the full length of burner.	Burner ports are clogged or blocked.	Clean burner ports.
Flame is yellow or orange.	New burner may have residual manufacturing oils.	Burn grill for 15 minutes with lid closed.
	Spider webs or insect nest in venturi tube.	Clean venturi tube.
	Food residue, grease or seasoning on burner.	Clean burner. Remove salt from burner.
	Poor alignment of valve to burner venturi tube.	Make sure burner venturi tube is properly connected to the valve.
Flame blows out.	High or gusting winds.	Turn front of grill to face wind or increase flame height.
	Low on propane gas.	Replace or refill propane tank.
	Excess flow valve tripped.	Refer to "Sudden drop in gas flow" and reduce the flame height.
Flare-up.	Grease build-up.	Clean grill.
	Excessive fat in meat.	Trim fat from meat before grilling.
	Excessive cooking temperature.	Adjust (lower) temperature accordingly.
Persistent grease fire.	Grease trapped by food build-up around burner system.	Turn knobs to the OFF position.
		Leave lid in closed position and let fire burn out. After grill cools, remove and clean all parts.
Flashback fire in burner tube(s).	Burner and/or burner venturi tubes are blocked.	Clean burner and/or burner venturi tubes
Inside of lid is peeling – like paint peeling.	Baked on grease build-up has turned to carbon and is flaking off.	Clean thoroughly.

Warranty Program

Proof of purchase is required to access this warranty program, which is in effect from the date of purchase. Inability to provide proof of purchase or after the warranty has expired, customers will be subject to parts, shipping and handling fees.

Product Registration is required to receive full warranty coverage, which is in effect from the date of purchase. Inability to register products within ten days from the date of purchase may result in charges including parts, shipping and handling fees. Customers can register their products online at www.pyromagicbbq.com or by returning the mail-in registration card.

Limited Warranty

10 Year Warranty on stainless steel burners.

1 Year Warranty on all parts in regards to damage affecting the operation of the gas grill.

Warranty Provisions:

This warranty is non-transferable and does not cover failures due to misuse or improper installation or maintenance. This warranty is for replacement of defective parts only. We are not responsible for incidental or consequential damages or labor costs.

This warranty does not cover chips and scratches of porcelain or painted surfaces, nor does it cover corrosion or discoloration due to misuse, lack of maintenance, hostile environment, accidents, alterations, abuse or neglect. This warranty does not cover damage caused by heat, abrasive and chemical cleaners, resulting in chipped porcelain enamel parts or any damage to other components used in the installation or operation of the gas grill.

Some state do not allow the limitation or exclusion of incidental or consequential damages, so the above limitations or exclusions may not apply to you. This warranty gives you specific legal rights, and you may also have other rights that vary from state to state.

If you have any questions related to the product or warranty, please visit our website at www.pyromagicbbq.com or call our customer service center at 1-877-885-8227, 6:00 AM to 5:00 PM (PST), Monday through Friday.

Manufactured by:

Lucas Innovation Inc.

Xiekeng District, QingXi Town,

Dong Guan, Guang Dong, China