

This Owner's Manual is provided and hosted by [Appliance Factory Parts](#).

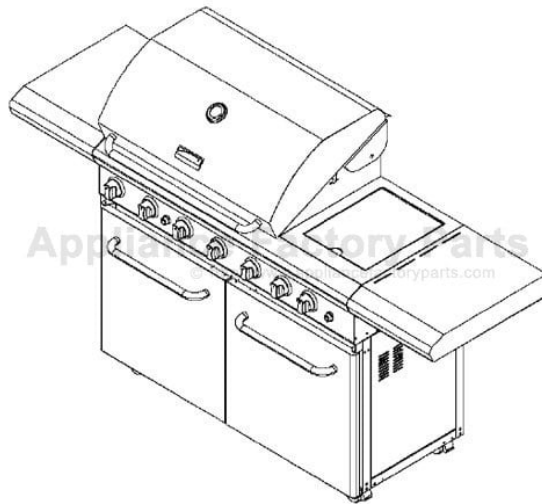

# Kenmore 141.16684 Owner's Manual

[Shop genuine replacement parts for Kenmore  
141.16684](#)



[Find Your Kenmore Grill Parts - Select From 1424 Models](#)

----- Manual continues below -----



Liquid Propane Gas (LPG) Grill  
Natural Gas (NG) Grill

# OPERATOR'S MANUAL

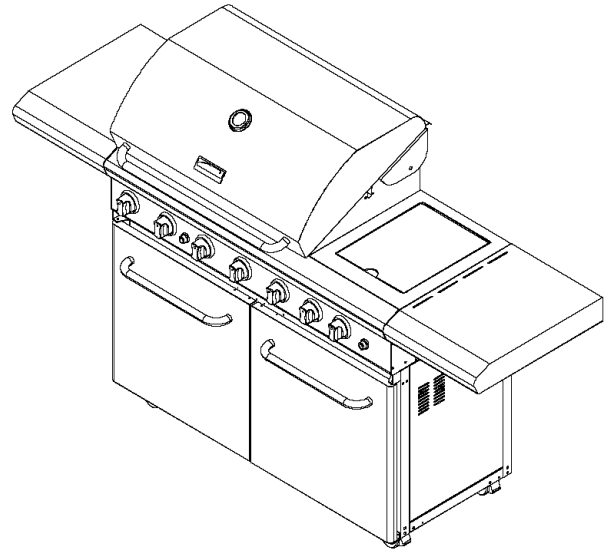
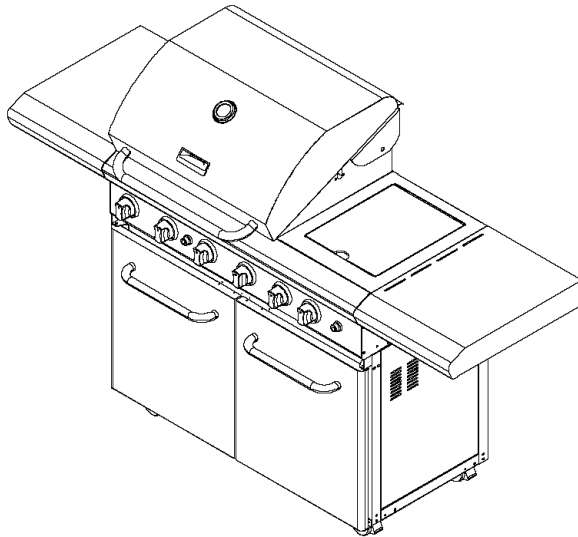

- Safety
- Assembly
- Use and Care
- Cooking Guide
- Frequently Asked Questions

Model 141.16682 and 141.17682

Model 141.16684 and 141.17684

## Grill Information Center:

**Call us first** if you have any problem with this product. We can help you with questions about assembly and grill operation or if there are damaged or missing parts when you unpack this unit from the shipping box. Please call before returning to the store.

**1-888-317-7642**  
8am-8pm CST, Monday through Friday

## IMPORTANT:

- **NOTE TO ASSEMBLER / INSTALLER:**  
Leave this manual with the consumer.
- **NOTE TO CONSUMER:**  
Keep this manual for future reference.
- **RECORD YOUR SERIAL #** \_\_\_\_\_  
(see silver CSA label on main body of grill)



## WARNING



- Failure to comply with these instructions could result in a fire or explosion that could cause serious bodily injury, death or property damage.
- Whether this grill was assembled by you or someone else, you must read this entire manual before using your grill to ensure the grill is properly assembled, installed and maintained.
- **Use your grill at least 3 feet away from any wall or surface.** Use your grill at least **3 feet away** from combustible objects that can melt or catch fire (such as vinyl or wood siding, fences and overhangs) or sources of ignition including pilot lights on water heaters and live electrical appliances.
- **THIS GAS APPLIANCE IS DESIGNED FOR OUTDOOR USE ONLY.**
- Combustion byproducts produced when using this product contain chemicals known to the State of California to cause cancer, birth defects, or other reproductive harm.

## Table of Contents

Primary Safety Warnings.....	1-3
Warranty Terms and Conditions.....	2
Pre-Assembly Instructions.....	3
Part Diagrams and Lists.....	4-8
Assembly Instructions.....	9-10
LP Gas Tank Installation.....	11-13
Natural Gas Connection.....	14
Use & Care Instructions:	
• Lighting Instructions.....	15
• Troubleshooting.....	16
Cleaning and Maintenance.....	17-18
Cooking Guide.....	A1-A6
Frequently Asked Questions.....	A7-A8

## Warranty

### Lifetime Limited Warranty on Kenmore Elite Grill Stainless Steel Parts

For the lifetime of this grill, if any of its stainless steel parts, except for cooking grids and Savor Plates™, is defective in material or workmanship, Sears will repair or replace the part, at our option, free of charge.

This warranty does not include discoloration of stainless steel parts due to normal use or excessive heat, nor does it include scratches or dents caused by normal use, accident, or improper maintenance.

### Two-Year Full Warranty on Kenmore Elite Grill

For two years from the date of purchase, if this grill is defective in material or workmanship, Sears will repair it free of charge.

If repair proves impossible, Sears will, at your option, either replace this grill with a new one, or refund the full purchase price.

This warranty excludes ignitor batteries and grill paint loss or rusting, which are either expendable parts that can wear out from normal use in less than a year, or are conditions that can be the result of normal use, accident or improper maintenance.

### Limited 3 Year Warranty on Selected Grill Parts

From 2 years after the date of purchase for a 3-year period, Sears will replace Cooking Grids, Savor Plates™ and All Other Parts (except for Ignitor battery) if they are defective in material and workmanship. You will be charged for labor.

### Warranty Service

Warranty service is available by contacting Sears at 1-800-4-MY-HOME ©

### Warranty Restrictions

- This warranty is void if grill is used for commercial or rental purposes.
- This grill is safety certified for use only in the country where purchased. Modification for use in any other location is a safety hazard and will void the warranty.
- This warranty gives you specific legal rights, and you may also have other rights which vary from state to state.

**Sears, Roebuck and Co., Dept. 817WA,  
Hoffman Estates, IL 60179 U.S.A.**

© Sears, Roebuck and Co.



## DANGER



### IF YOU SMELL GAS:

1. Shut off gas to the appliance.
2. Extinguish any open flame.
3. Open lid.
4. If odor continues, keep away from the appliance and immediately call your gas supplier or your fire department.



## WARNING



1. Do not store spare LP cylinder within 10 feet (3m) of this appliance.
2. Do not store or use gasoline or other flammable liquids and vapors within 25 feet (8m) of this appliance.
3. When cooking with oil/grease, do not allow the oil/grease to get hotter than 350°F (117°C).
4. Do not leave oil/grease unattended.



## WARNING



- LPG grill models must be used with Liquid Propane Gas and the regulator assembly supplied. Natural Gas models must be used with Natural Gas only. Any attempt to convert the grill from one fuel type to another is extremely hazardous and will void the warranty.
- **Never** use your gas grill in a garage, porch, shed, breezeway or any other enclosed area.
- **Never** obstruct the flow of ventilation air around your gas grill housing.
- Keep gas regulator hose away from hot grill surfaces and dripping grease. Avoid unnecessary twisting of hose. Visually inspect hose prior to each use for cuts, cracks, excessive wear or other damage. If the hose appears damaged do not use the gas grill. Call Sears at 1-800-4-MY-HOME® (1-800-469-4663) for a Kenmore replacement hose.

### Grill Installation Codes

The installation must conform with local codes or, in the absence of local codes, with either the National Fuel Gas Code, ANSI Z223.1/NFPA 54, or CAN/CGA-B149.1, Natural Gas and Propane Installation Code.

## Pre-Assembly Instructions For Your Safety



### CAUTION



Failure to comply with these instructions may result in a hazardous situation which, if not avoided, may result in injury.

Spiders and small insects can spin webs and nest in the grill Burner Tubes during transit and warehousing which can lead to a gas flow obstruction resulting in a fire in and around the Burner Tubes. This type of "FLASHBACK FIRE" can cause serious grill damage and create an unsafe operating condition for the user.

**To reduce the chance of FLASHBACK FIRE you must clean the Burner Tubes as follows before assembling your grill.**

Also do this at least once a month in summer and fall or whenever spiders are active in your area, and if your grill has not been used for an extended period of time.

1. Remove the screw from the rear of each Burner using a Phillips Head Screwdriver.
2. Carefully lift each Burner up and away from the Gas Valve Orifice.
3. Check and clean Burner/Venturi Tubes for insects and insect nests. A clogged tube can lead to a fire beneath the grill.
4. Refer to the figure below and perform one of these 3 cleaning methods:

- METHOD 1:** Bend a stiff wire or wire coat hanger into a small hook as shown and run the hook through the Burner Tube and inside the Burner several times to remove debris.



TO CLEAN BURNER TUBE, INSERT HOOK HERE

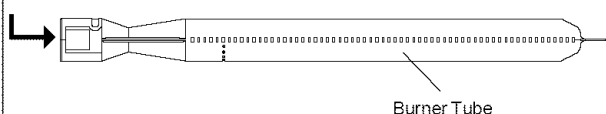

- METHOD 2:** Use a bottle brush with a flexible handle and run the brush through the Burner Tube and inside the Burner several times to remove any debris.
- METHOD 3:** Use an air hose to force air through each Burner Tube. The forced air should pass debris or obstructions through the Burner and out the Ports.



### WARNING



For safe operation ensure the Gas Valve Assembly Orifice is inside the Burner Tube before using your grill. See figure. If the Orifice is not inside the Burner Tube, lighting the Burner may cause explosion and/or fire resulting in serious bodily injury and/or property damage.

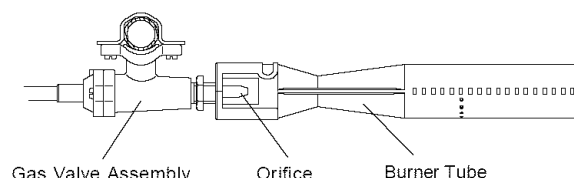

### PRE-ASSEMBLY

Read and perform the following pre-assembly instructions:

- Tools Required for Assembly** include:
- protective work gloves
  - protective eyewear
  - #3 Phillips Head Screwdriver (included in hardware pack in Parts Box)
- While it is possible for one person to unpack this gas grill, obtain assistance from another person when handling the large pieces.
- Use the Hardware and Part Diagrams to ensure all items are included and free of damage.
- Do not assemble or operate the grill if it appears damaged. If there are damaged or missing parts when you unpack the shipping box or you have questions during the assembly process, call the:
- Grill Information Center 1-888-317-7642**  
**8am-8pm CST, Monday through Friday**

## Hardware Pack Parts List for 141.16682, 141.17682, 141.16684 & 141.17684

PART #	PART DESCRIPTION	QTY	PURPOSE OF PART
P06001037A	Hardware Pack	1	For use in assembly
S112G04121	Phillips Head Screw 1/4"x3/4"	10	Attaches Side Shelves to Bowl Panel
<b>Already installed in the Tool Holder Kit</b>			
S112M05081	Phillips Head Screw M5x8mm	2	Attaches Tool Holder to Left Side Shelf
<b>Already installed in the Tank Pull-Out Tray</b>			
S233G04382	Wing Bolt 1/4"x4-3/8"	1	Secures Gas Tank
S303G0404A	Special Nut 1/4"	1	

## Hardware Pack Diagram for 141.16682, 141.17682, 141.16684 & 141.17684

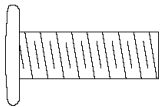

Phillips Head Screw 1/4"x3/4"  
Qty. 10  
Part # S112G04121  
(Stainless Steel)

### Hardware already installed in the Tool Holder Kit

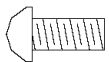

Phillips Head Screw M5x8mm  
Qty. 2  
Part # S112M05081  
(Stainless Steel)

### Hardware already installed in the Tank Pull-Out Tray



Special Nut 1/4"  
Qty. 1  
Ref. # S303G0404A  
(Black Painted)  
Scale 1:2

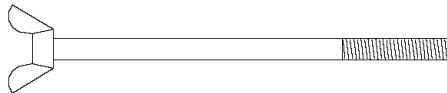

Wing Bolt 1/4"x4-3/8"  
Qty. 1  
Ref. # S233G04382  
(Black Painted)  
Scale 1:2

\* Two Batteries/AA and #3 Phillips Head Screwdriver included in the Hardware Pack.

# Parts Diagram for Models 141.16682 & 141.17682

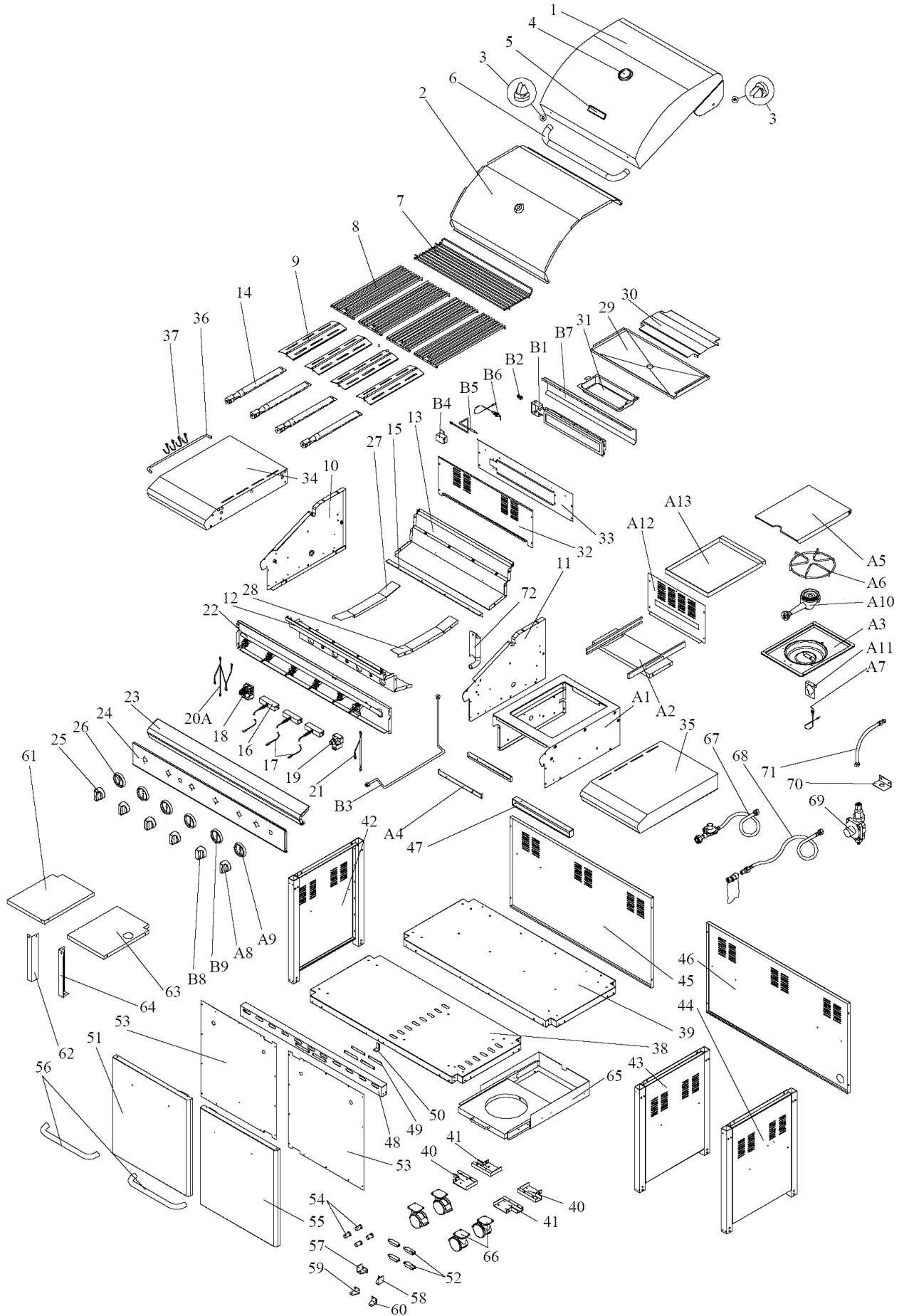

# Parts Diagram for Models 141.16684 & 141.17684

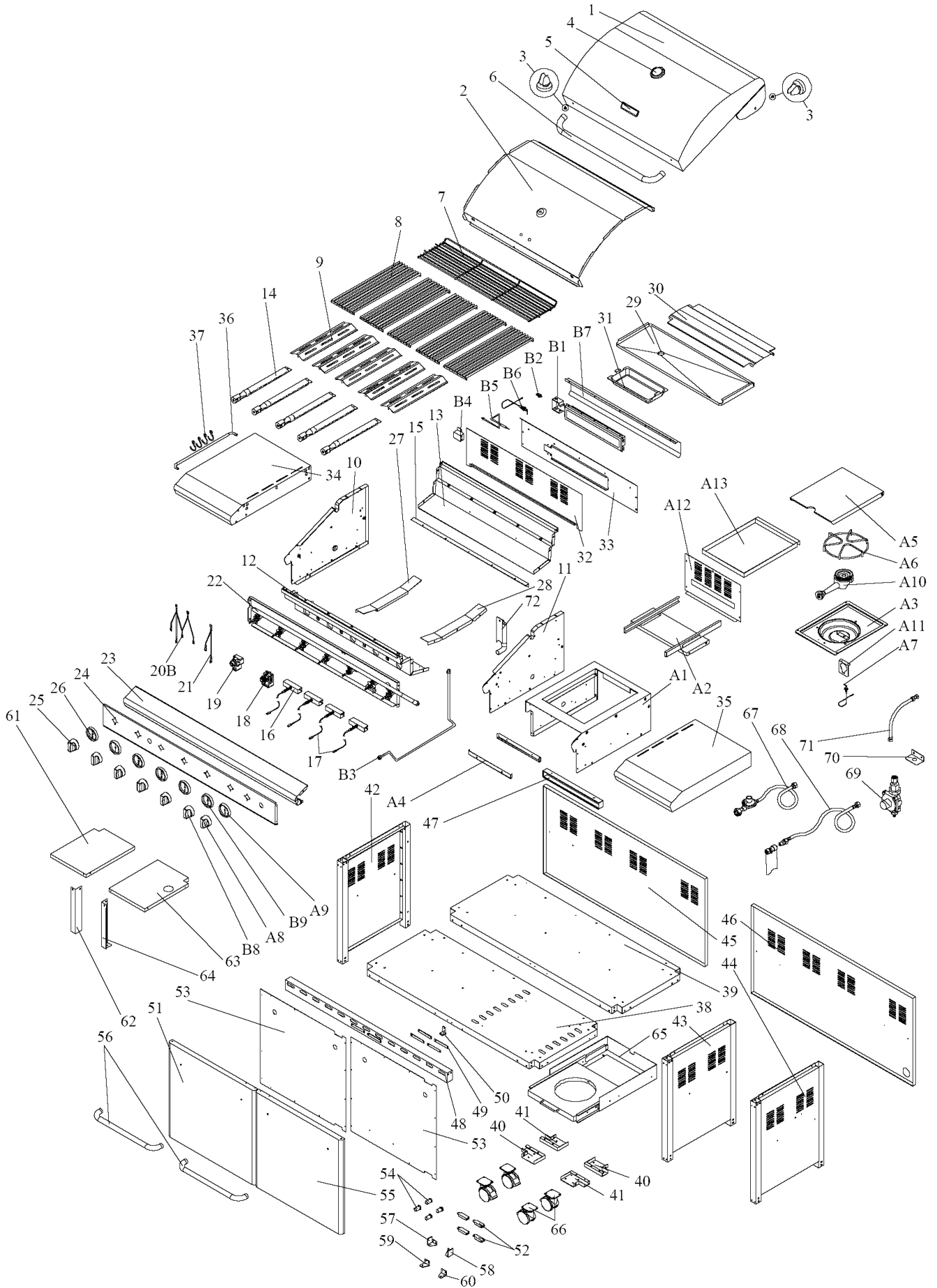

## Parts List for Models 141.16682, 141.17682, 141.16684 & 141.17684

KEY	DESCRIPTION	P/N 16682 17682	P/N 16684 17684	QTY 16682 17682	QTY 16684 17684
1	Lid	P00119126A	P00119146A	1	1
2	Lid Trim Plate	P0011408DV	P0011409DV	1	1
3	Protective Pad	P05518001I	P05518001I	4	4
4	Temperature Gauge	P00601071A	P00601071A	1	1
5	Name Plate	P00410038C	P00410038C	1	1
6	Lid Handle	P00205055B	P00205034B	1	1
7	Cooking Rack/Secondary	P01514003B	P01515004B	1	1
8	Cooking Grid	P01604004B	P01604004B	4	5
9	Savor Plate™	P01708009B	P01708009B	4	5
10	Bowl Panel, Left	P00720283C	P00720283C	1	1
11	Bowl Panel, Right	P00721263C	P00721263C	1	1
12	Bowl Panel, Front	P0073816BC	P0073814BC	1	1
13	Bowl Panel, Rear	P0072521BC	P0072526BC	1	1
14	Burner/Main (LPG only)	P02008010A	P02008010A	4	5
	Burner/Main (NG only)	P02008011A	P02008011A	4	5
15	Burner Bracket	P0220902CA	P0221001CA	1	1
16	Gas Collector Box with Electrode	P02608002A	P02608002A	3	4
17	Electric Wire Set	P02615025A	P02615028A	1	1
18	Electric Ignitor, 4-port	P02502134C	P02502134C	1	1
19	Electric Ignitor, 2-port	P02502062C	P02502062C	1	1
20A	Electric Wire Set, 4-contact	P02615026A		1	
20B	Electric Wire Set, 5-contact		P02615040A		1
21	Electric Wire Set, 2-contact	P02615027A	P02615027A	1	1
22	Gas Valve/Manifold Assembly (LPG only)	Y0060175	Y0060177	1	1
	Gas Valve/Manifold Assembly (NG only)	Y0060176	Y0060178	1	1
23	Decorative Front Cover	P07508007A	P07508008A	1	1
24	Control Panel (LPG only)	P02911071B	P02911081B	1	1
	Control Panel (NG only)	P02911071G	P02911081G	1	1
25	Control Knob for Main Burner	P03419053H	P03419053H	4	5
26	Control Knob Seat	P03415263L	P03415263L	4	5
27	Grease Tray Track, Left	P05330008C	P05330008C	1	1
28	Grease Tray Track, Right	P05330009C	P05330009C	1	1
29	Grease Draining Tray	P02706126A	P02707036A	1	1
30	Grease Draining Tray Heat Shield	P06903025B	P06903026B	1	1
31	Grease Receptacle	P02701075B	P02701075B	1	1
32	Bowl Wind Shield	P06906011C	P06906014C	1	1
33	Back Burner Frame	P02011012B	P02011013B	1	1
34	Side Shelf, Left	P01106006B	P01106006B	1	1
35	Side Shelf, Right	P01107008B	P01107008B	1	1
36	Tool Holder	P05514008A	P05514008A	1	1
37	Tool Hook	P05514053F	P05514053F	4	4
38	Cart Bottom Shelf (LPG only)	P01010006C	P01010008C	1	1
39	Cart Bottom Shelf (NG only)	P01010007C	P01010009C	1	1
40	Caster Seat, Left Front & Right Rear	P05327007G	P05327007G	2	2
41	Caster Seat, Right Front & Left Rear	P05327008G	P05327008G	2	2
42	Cart Legs with Side Panel, Left	P07614004A	P07614004A	1	1
43	Cart Legs with Side Panel, Right (LPG only)	P07615005A	P07615005A	1	1
44	Cart Legs with Side Panel, Right (NG only)	P07615006A	P07615006A	1	1
45	Cart Rear Panel (LPG only)	P07701034A	P07701036A	1	1
46	Cart Rear Panel (NG only)	P07701035A	P07701037A	1	1
47	Cart Rear Panel Bracket	P03306006C	P03306006C	1	1
48	Cart Bracket, Front	P03306007C	P03306008C	1	1
49	Door Stop Plate	P05510002L	P05510002L	4	4
50	Door Guide Plate	P05510006A	P05510006A	1	1

## Parts List for Models 141.16682, 141.17682, 141.16684 & 141.17684

KEY	DESCRIPTION	P/N 16682 17682	P/N 16684 17684	QTY 16682 17682	QTY 16684 17684
51	Door, Left	P04302022A	P04302023A	1	1
52	Door Magnet	P05523002K	P05523002K	4	4
53	Door Trim Plate	P07510004E	P07510005E	2	2
54	Door Spacer	P06801010G	P06801010G	4	4
55	Door, Right	P04303022A	P04303023A	1	1
56	Door Handle	P00205037B	P00205057B	2	2
57	Door Hinge Bracket, Top/Left	P03314005C	P03314005C	1	1
58	Door Hinge Bracket, Top/Right	P03314006C	P03314006C	1	1
59	Door Hinge Bracket, Bottom/Left	P03314007C	P03314007C	1	1
60	Door Hinge Bracket, Bottom/Right	P03314008C	P03314008C	1	1
61	Cart Partition Panel, Left	P07512001D	P07512003D	1	1
62	Cart Partition Panel Bracket, Left	P03303014J	P03303014J	1	1
63	Cart Partition Panel, Right (NG only)	P07512004D	P07512004D	1	1
64	Cart Partition Panel Bracket, Right (NG only)	P03303015J	P03303015J	1	1
65	Tank Pull-Out Tray Assembly (LPG only)	Y0340035	Y0340035	1	1
66	Caster, 3 in., with Brake	P05119001A	P05119001A	4	4
67	Regulator with Hose (LPG only)	P03631002A	P03631002A	1	1
68	Hose, 12 ft. (NG only)	P03703001A	P03703001A	1	1
69	Regulator Assembly (NG only)	Y0080016	Y0080016	1	1
70	Regulator Bracket (NG only)	P03303016J	P03303016J	1	1
71	Connection Tube (NG only)	P03705021A	P03705021A	1	1
72	Lighting Tube	P05313006C	P05313006C	1	1
A1	Bowl Panel, Outside Right	P00743036C	P00743036C	1	1
A2	Side Burner Grease Tray Track Assembly	P05516009G	P05516009G	1	1
A3	Side Burner Body	P02301011B	P02301011B	1	1
A4	Side Burner Body Bracket	P03306005C	P03306005C	2	2
A5	Side Burner Lid	P00115346A	P00115346A	1	1
A6	Side Burner Pot Support	P00805013B	P00805013B	1	1
A7	Side Burner Electrode	P02607006C	P02607006C	1	1
A8	Control Knob for Side Burner	P03419053H	P03419053H	1	1
A9	Control Knob Seat	P03415263L	P03415263L	1	1
A10	Side Burner with Brass Ring	P02002011D	P02002011D	1	1
A11	Side Burner Bracket	P02215072E	P02215072E	1	1
A12	Side Burner Wind Shield	P06906013C	P06906013C	1	1
A13	Side Burner Grease Draining Tray	P02718015B	P02718015B	1	1
B1	Back Burner Assembly	P02007003A	P02007003A	1	1
B2	Back Burner Orifice (LPG only)	P06509003A	P06509003A	1	1
	Back Burner Orifice (NG only)	P06509004A	P06509004A	1	1
B3	Back Burner Extension Tube	P03717017A	P03717018A	1	1
B4	Back Burner Gas Collector Box	P02621001K	P02621001K	1	1
B5	Back Burner Thermocouple	P05305001A	P05305004A	1	1
B6	Back Burner Electrode	P02614003C	P02614009C	1	1
B7	Back Burner Wind Shield	P06906012C	P06906015C	1	1
B8	Control Knob for Back Burner	P03419063H	P03419063H	1	1
B9	Control Knob Seat	P03415263L	P03415263L	1	1
	Hardware Pack	P06001037A	P06001037A	1	1
	Operator's Manual	P80103004A	P80103004A	1	1

For the repair or replacement parts you need:

Call anytime **1-800-4-MY-HOME**<sup>®</sup> (1-800-469-4663)

To obtain the correct replacement parts for your gas grill, please refer to the part numbers in this parts list. The following information is required to ensure you receive the correct parts:

1. Model and Serial Number (see CSA label on grill)
2. Part Number
3. Part Description
4. Quantity of parts needed

**Important:** Use only Kenmore replacement parts. The use of any part that is not a Kenmore replacement part can be dangerous and will also void your product warranty. Keep this Operator's Manual for convenient referral and for part replacement.

# Assembly Instructions

**CAUTION :** While it is possible for one person to assemble this grill, obtain assistance from another person when handling some of the larger, heavier pieces.

## 1 Install Side Shelves

- Remove screws S112M05081 from the Tool Holder. Slide the 4 Tool Hooks onto the Tool Holder with the hooks facing the Left Side Shelf. Attach Tool Holder to Side Shelf using these screws.
- Align the 2 holes on Front and Rear Bowl Panels and 3 holes on Left Bowl Panel with the threaded holes on Left Side Shelf. Tighten securely using 3 screws S112G04121.
- Align the 2 holes on under side of Left Side Shelf with the threaded holes on Left Bowl Panel. Tighten securely using 2 screws S112G04121.
- Align the 5 holes on under side of Right Side Shelf with the threaded holes on Right Outside Bowl Panel. Tighten securely using 5 screws S112G04121.



Phillips Head Screw  
M5x8mm  
Qty. 2  
Part # S112M05081  
(Stainless Steel)

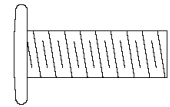

Phillips Head Screw  
1/4"x3/4"  
Qty. 10  
Part # S112G04121  
(Stainless Steel)

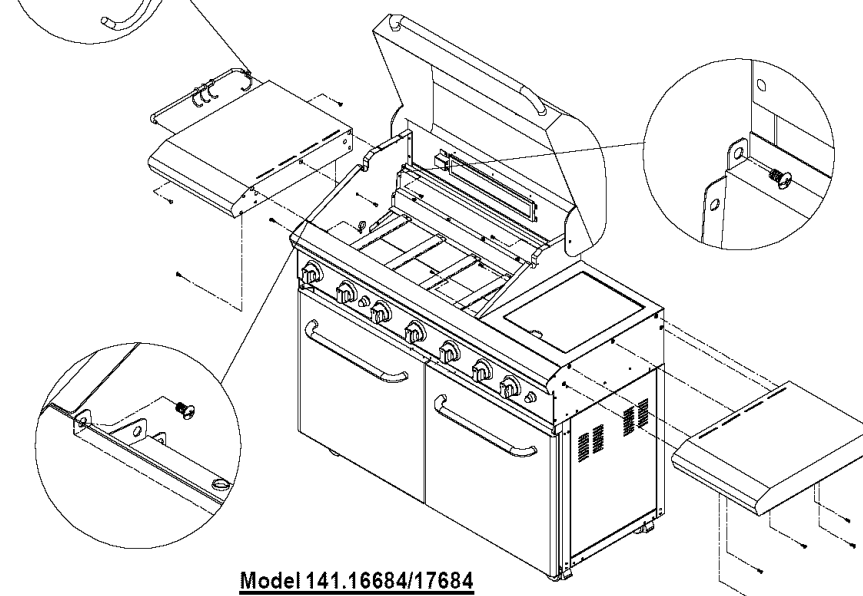
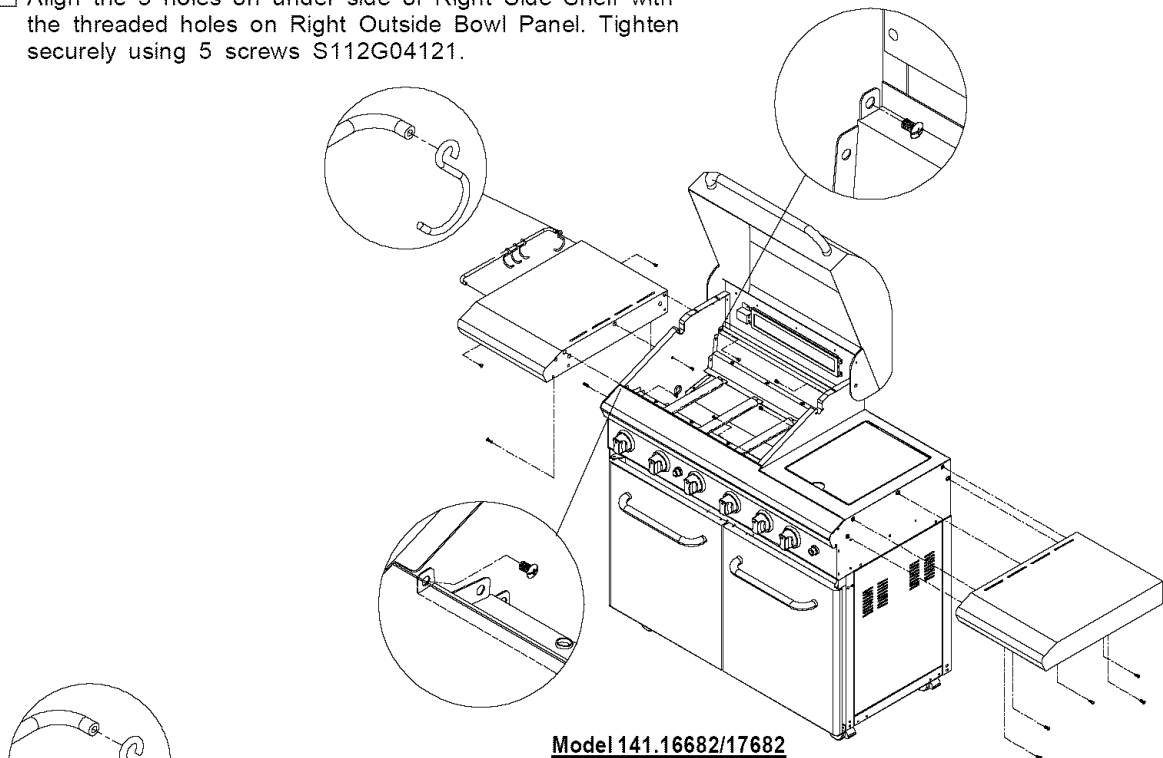

## 2 Install Ignitor Batteries

- Unscrew Ignitor Caps from Control Panel.
- Place one supplied AA battery into each Ignitor Slot with positive pole facing you.
- Position the Cap and Spring over the AA battery in each Ignitor Slot and tighten to Control Panel.

## 3 Main Burners Electrode Check Perform this Electrode Check with the assistance of another person.

This test will ensure that the Spark Electrode Tips are properly positioned so your grill lights easily and properly.

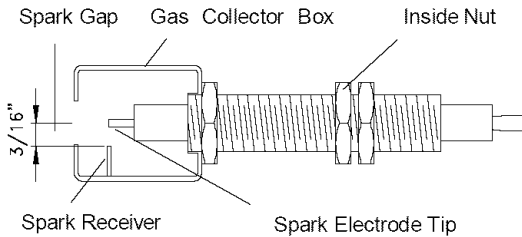

- Be sure all Control Knobs are set to "OFF" and open the Grill Lid.
- Have your assistant stand behind to the right of the grill and look toward the front of the grill bowl. **Never** put your face inside the Grill Bowl.
- Turn any Control Knob of Main Burners to IGN and push in and have assistant watch for a blue spark within each Gas Collector Box.
- If no spark is seen, the Spark Gap needs to be adjusted as follows:
  - Using an adjustable wrench, loosen the Inside Nut until the Gas Collector Box can be turned upward.
  - If the gap between the Spark Electrode Tip and Receiver is more than 3/16" use long nose pliers to gently squeeze the Gas Collector Box to narrow gap.
  - Return the Gas Collector Box to its original position, secure the Inside Nut and try the Electrode Check again. If no "clicking" sound is heard:
    - AA Battery may be installed backwards.
    - Electric wires may be loose. Remove the AA Battery and inspect the Ignitor Junction Box found behind the Control Panel and reconnect any loose wires.

## 4 Side Burner and Back Burner Electrode Check

- Open side burner lid. Remove plastic shipping band from burner and pot support.
- Turn side burner Control Knob to IGN and push in. Look for spark between tip of electrode and burner.
- Open Grill Lid. Turn back burner Control Knob to IGN and push in. Look for spark between tip of electrode and burner.
- If you don't see a spark from side or back burner electrode, adjust gap between electrode and burner surface to 3/16 in.

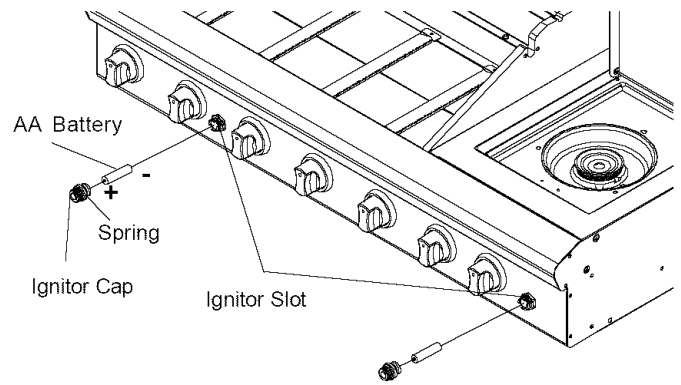

## 5 Install Cooking Components

- Place the Savor Plates™ on lower ledge above Burners.
- Place Cooking Grids on bowl ledge.
- Place the Secondary Cooking Rack into the slots on Grill Bowl Side Panels.
- Place the Side Burner Pot Support on Side Burner Body.

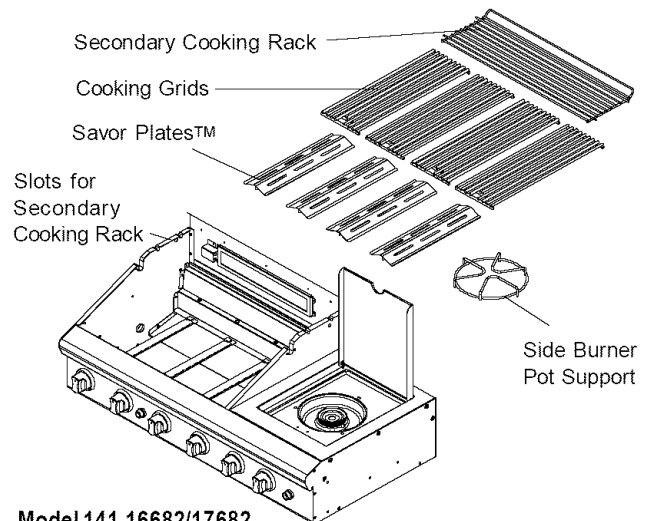

**Model 141.16682/17682**

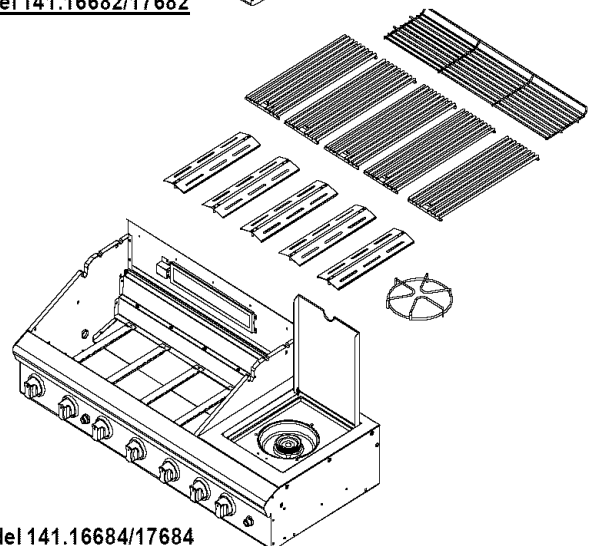

**Model 141.16684/17684**

## Final Grill Assembly Step



When you have finished assembling your grill be sure that all screws are tightened for safe operation of your grill.

## LP Gas Tank Installation



### CORRECT LP GAS TANK USE

- LP Gas grill models are designed for use with a standard 20 lb. Liquid Propane Gas (LP Gas) tank, not included with grill. **Never** connect your gas grill to an LP Gas tank that exceeds this capacity. A tank of approximately 12 inches in diameter by 18-1/2 inches high is the maximum size LP Gas tank to use. **You must use an "OPD" gas tank which offers a listed Overfill Prevention Device.** This safety feature prevents tank from being overfilled which can cause malfunction of LP Gas tank, regulator and/or grill.
- The LP Gas tank must be constructed and marked in accordance with the Specifications for LP-Gas Cylinders of the U.S. Department of Transportation (D.O.T.) or the National Standard of Canada, CAN/CSA-B339, Cylinders, Spheres and Tubes for Transportation of Dangerous Goods; and Commission, as applicable.
- The LP Gas tank must have a shutoff valve, terminating in an LP Gas supply tank valve outlet, that is compatible with a Type 1 tank connection device. The LP Gas tank must also have a safety relief device that has a direct connection with the vapor space of the tank.
- The tank supply system must be arranged for vapor withdrawal.
- The LP Gas tank used must have a collar to protect the tank valve.
- Never** connect an unregulated LP gas tank to your gas grill. The gas regulator assembly supplied with your gas grill is adjusted to have an outlet pressure of 11" water column (W.C.) for connection to an LP gas tank. Only use the regulator and hose assembly supplied with your gas grill. Replacement regulators and hose assemblies must be those specified by Kenmore.
- Have your LP Gas dealer check the release valve after every filling to ensure it remains free of defects.
- Always keep LP Gas tank in upright position.
- Do not subject the LP Gas tank to excessive heat.
- Never store an LP Gas tank indoors. If you store your gas grill in the garage **always** disconnect the LP Gas tank first and store it safely outside.
- LP Gas tanks must be stored outdoors in a well-ventilated area and out of the reach of children.
- Disconnected LP Gas tanks must not be stored in a building, garage or any other enclosed area.
- The regulator and hose assembly can be seen after opening the doors (if applicable) and must be inspected before each use of the grill. If there is excessive abrasion or wear or if the hose is cut, it must be replaced prior to using the grill again.
- Never** light your gas grill with the lid closed or before checking to ensure the burner tubes are fully seated over the gas valve orifices.
- Never** allow children to operate your grill. Do not allow children or pets to play near your grill.

- Use of alcohol or drugs may impair the ability to assemble and operate the appliance.
- Keep fire extinguisher readily accessible. In the event of a oil/grease fire, do not attempt to extinguish with water. Use type B extinguisher or smother with dirt, sand or baking soda.
- In the event of rain, cover the grill and turn off the burner and gas supply.
- Use your grill on a level, stable surface in an area clear of combustible materials.
- Do not leave grill unattended when in use.
- Do not move the appliance when in use.
- Allow the grill to cool before moving or storing.
- Do not use your grill as a heater.
- This grill is not intended to be installed in or on recreational vehicles and/or boats.

 **WARNING** 

A. Do not store a spare LP-Gas tank under or near this appliance.  
B. Never fill the tank beyond 80 percent full; and  
C. If the information in "(a)" and "(b)" is not followed exactly, a fire causing death or serious injury may occur.

 **WARNING** 

- **Use your grill outdoors, at least 3 feet away from any wall or surface.** Use your grill at least **3 feet away** from combustible objects that can melt or catch fire (such as vinyl or wood siding, fences and overhangs) or sources of ignition including pilot lights on water heaters and live electrical appliances.
- **Never** use your gas grill in a garage, porch, shed, breezeway or any other enclosed area.
- **Never** obstruct the flow of ventilation air around your gas grill housing.

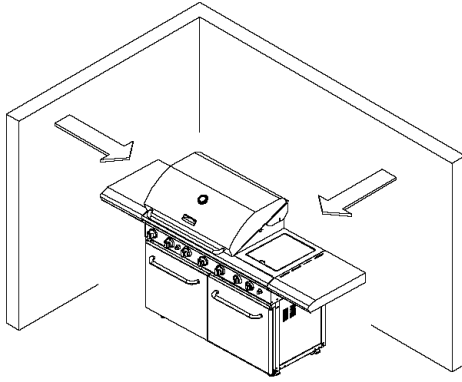

**NOTE about LP Gas Tank Exchange Programs**

- Many retailers that sell grills offer you the option of replacing your empty LP Gas tank through an exchange service. Use only those reputable exchange companies that inspect, precision fill, test and certify their tanks. Exchange your tank only for an OPD safety feature-equipped tank as described in the LP Gas tank section of this manual.
- Always keep new and exchanged LP Gas tanks in an upright position during use, transit or storage.
- Leak test new and exchanged LP Gas tanks BEFORE connecting one to your grill.

**How to Leak Test your LP Gas Tank**

**For your safety:**

- All leak tests must be repeated each time your LP Gas tank is exchanged or refilled.
- When checking for gas leaks do not smoke.
- Do not use an open flame to check for gas leaks.
- Your grill must be leak tested outdoors in a well-ventilated area, away from ignition sources such as gas fired or electrical appliances. During the leak test, keep your grill away from open flames or sparks.
- Do not use household cleaning agents. Damage to gas assembly components can result.
  - Use a clean paintbrush and a 50/50 mild soap and water solution.
  - Brush soapy solution onto LP Gas tank in the areas indicated by the arrows. See diagram.
  - If growing bubbles appear do not use or move the LP Gas tank. Call an LP Gas Supplier or your Fire Department.

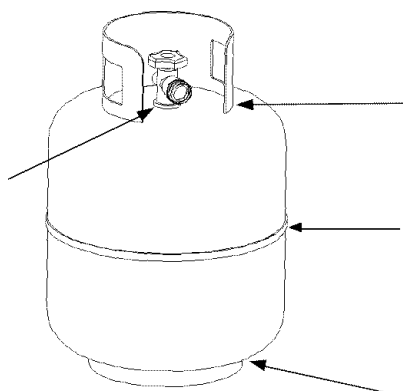

**To Install LP Gas Tank (LPG model only):  
Secure a 20lb LP Gas Tank to Gas Grill**

- Screw the Wing Bolt and Special Nut to Tank Pull-Out Tray.
- Turn your LP Gas Tank Valve clockwise to the closed or OFF position.
- Place LP Gas tank into tank hole on bottom shelf or (on select models) slide the Tank Tray out of the cabinet until it is fully extended. The Tank Tray has an auto lock position and may need to be pulled firmly.
- Install the tank so the Tank Valve faces the rear right corner of cabinet.
- Secure Gas Tank with Special Nut and Wing Bolt.

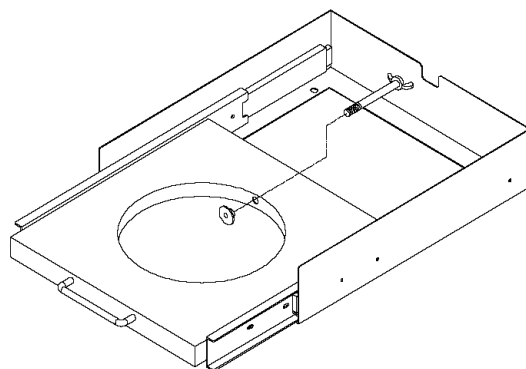

**The Special Nut has to be mounted to the Wing Bolt BEFORE inserting tank into tank hole.**

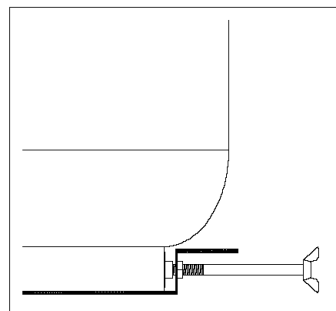

**With the Special Nut, the Wing Bolt holds the tank foot firmly.**

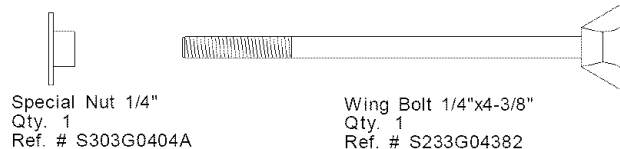

## WARNING

If growing bubbles appear do not use or move the LP Gas tank. Contact an LP Gas Supplier or your fire department!

**NOTE:** Many different size propane gas tank bottom collars are available in the market, especially with the popularity of tank exchange programs. If your tank bottom collar does not fit into the tank hole after attaching the special nut to the wing bolt, simply remove the special nut and secure the tank using the wing bolt only.

### LP Gas Model only:

#### Connect Regulator with Hose to your LP Gas Tank

- Turn all Burner Valves to the OFF position.
- Inspect the valve connection port and regulator assembly for damage or debris. Remove any debris. Never use damaged or plugged equipment.
- Connect the regulator assembly to the tank valve and HAND TIGHTEN nut clockwise to a full stop. DO NOT use a wrench to tighten because it could damage the Quick Coupling Nut and result in a hazardous condition.
- Open the tank valve 1/4 to 1/2 (counterclockwise) and use a soapy water solution to check all connections for leaks before attempting to light your grill. See "**Checking for LP Gas Leaks**". If a leak is found, turn the tank valve off and do not use your grill until the leak is repaired.

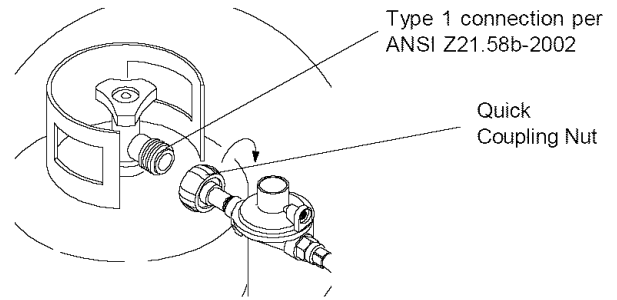



**CAUTION:** When the appliance is not in use the gas must be turned off at the tank.

#### Check all connections for LP Gas Leaks

**Never** test for leaks with a flame. Prior to first use, at the beginning of each season, or every time your LP Gas tank is changed, you must check for gas leaks. Follow these three steps:

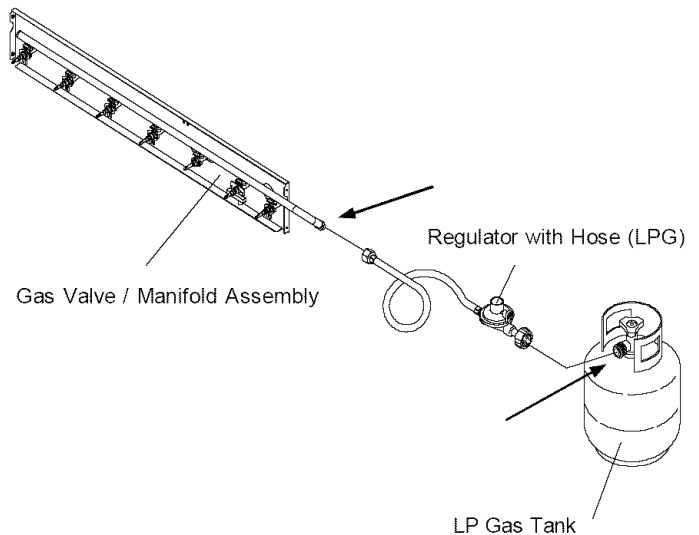
- Make a soap solution by mixing one part liquid detergent and one part water.
- Turn the grill Control Knobs to the full OFF position, then turn the gas ON at source.
- Apply the soap solution to all gas connections indicated by the arrows. See diagram. If bubbles appear in the soap solution the connections are not properly sealed. Check each fitting and tighten or repair as necessary.



	<b>WARNING</b>	
<p>If you have a gas leak that cannot be repaired by tightening, turn off the gas at the source, disconnect fuel line from your grill and call 1-800-4-MY-HOME® or your gas supplier for repair assistance.</p>		

#### Disconnecting A Liquid Propane Gas (LPG) Tank From Your Grill

- Make sure the Burner Valves and LP Gas tank valve are off. (Turn clockwise to close.)
- Detach the hose and regulator assembly from the LP Gas tank valve by turning the Quick Coupling Nut counterclockwise.

# Natural Gas Connection

## Natural Gas Model only: Connecting Natural Gas To Your Grill

- Connect the Swivel nut of the 12' Natural Gas Hose to the vertical fitting of NG Regulator as shown in **Fig. 1**. Connect the other hose end (male plug) to the gas supply line from house. Also, read and follow all natural gas safety instructions below.

## Natural Gas Safety Instructions

- Your natural gas grill is designed to operate on natural gas only, at a pressure of 4" water column (W.C.) with natural gas regulator. The gas pressure Regulator supplied with this appliance must be used. This Regulator is set for an outlet pressure of 4" W.C.
- Install a Shutoff Valve at the gas supply source outdoors at a point after the gas pipe exits the outside wall and before the quick-disconnect hose. Or install it at the point before the gas line piping enter the ground. See **Fig. 2**.
- Pipe sealing compound or pipe thread tape resistant to the action of natural gas must be used on all male pipe thread connections.
- Disconnect your gas grill from fuel source when the gas supply is being tested at high pressures. This gas grill and its individual shutoff valve must be disconnected from the gas supply pipe system during any pressure testing of that system at pressure in excess of 1/2 psi (3.5kpa).
- Turn off your gas grill when the gas supply is being tested at low pressures. The grill must be isolated from the gas supply pipe system by closing its individual manual shutoff valve during any pressure testing of the gas supply pipe system at pressures equal to or less than 1/2 psi (3.5kpa).

**Figure 2**

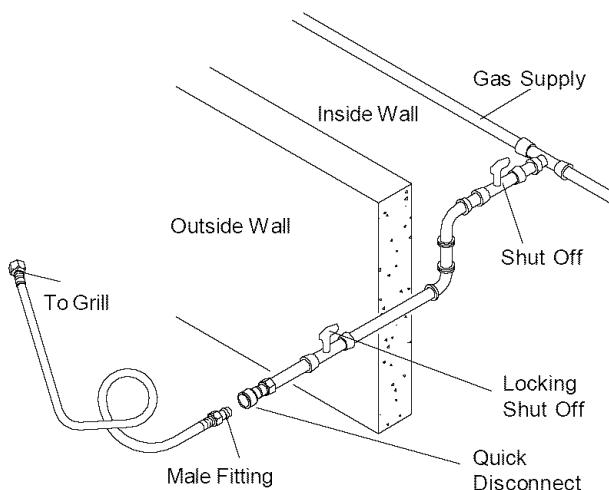

**Figure 1**

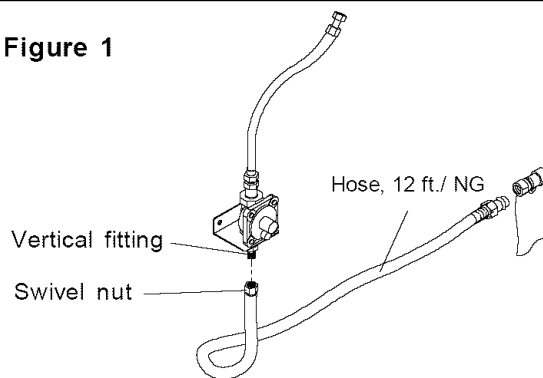

## Check all connections for NG Leaks

**Never** test for leaks with a flame. Prior to first use, at the beginning of each season, you must check for gas leaks. Follow these three steps:

- Make a soap solution by mixing one part liquid detergent and one part water.
- Turn the grill Control Knobs to the full OFF position, then turn the gas ON at source.
- Apply the soap solution to all gas connections indicated by the arrows. See **Fig. 3**. If bubbles appear in the soap solution the connections are not properly sealed. Check each fitting and tighten or repair as necessary.

**Figure 3**

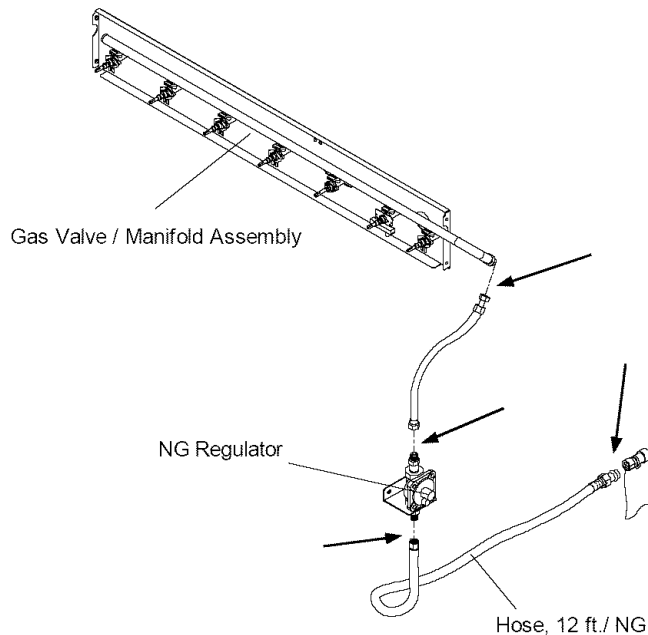

⚠	<b>WARNING</b>	⚠
<p>If you have a gas leak that cannot be repaired by tightening, turn off the gas at the source, disconnect fuel line from your grill and call 1-800-4-MY-HOME® or your gas supplier for repair assistance.</p>		

# USE AND CARE INSTRUCTIONS

## Grill Lighting Instructions

1. Before each use, check all hoses for cracks, nicks, cuts, burns or abrasions. If a hose is damaged in any way, do not use your grill before replacing the hose with an authorized part from the Parts List. Also make sure all gas supply connections are securely tightened.
2. Familiarize yourself with the safety and Use and Care instructions in this manual. Do not smoke while lighting grill or checking gas supply connections.
3. Be sure the LP Gas tank is filled or the Natural Gas Line is attached to the gas source.
4. Open the Grill Lid.
5. Check that the end of each Burner Tube is properly located over each Valve Orifice.

### WARNING

Failure to replace a faulty hose, secure gas supply connections or to open the Lid before proceeding to the Lighting Procedures could result in a fire or explosion that could cause serious bodily injury, death, or property damage.

6. Set Control Knobs to OFF and open the LP Gas tank valve **SLOWLY 1/4 of a turn**. For Natural Gas open the Shut Off Valve at source.

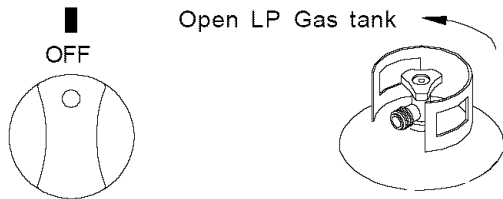

7. Push and turn the **LEFT Control Knob to IGN**. Push the Control Knob in to automatically ignite the Burner.

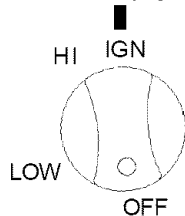

**Model 141.16682/17682**

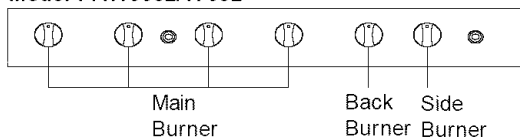

**Model 141.16684/17684**

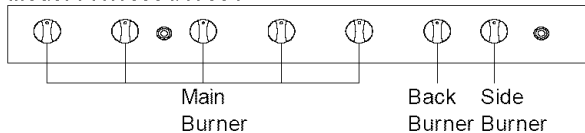

8. If ignition does not occur in 5 seconds, turn the burner Control Knob(s) and gas source OFF and conduct a leak test of ALL gas connections and gas sources as explained in the Use and Care section of this manual. If no leaks are detected, wait 5 minutes for any gas to clear and repeat the lighting procedure.
9. After one Burner is lit, turn the tank valve **SLOWLY** one more 1/4 of a turn for 1/2 of one complete turn.
10. Once one Burner is lit, the adjacent Burner can be lit by turning its Control Knob to HIGH.

## Back Burner Lighting Instructions

1. Follow steps 1 through 6 of the Grill Lighting Instructions.
2. Push and turn the Control Knob to IGN. Push the Control Knob in to automatically ignite the Burner. Once the burner is lit, turn the knob back to ON, keep pressing the knob and holding it for at least 10 seconds before releasing.
3. If ignition does not occur in 5 seconds, turn the Control Knob(s) and gas source OFF and conduct a leak test as explained in the Use and Care section of this manual. If no leaks are detected, wait 5 minutes for any gas to clear and repeat the lighting procedure.
4. After Burner is lit, turn the tank valve **SLOWLY** one more 1/4 of a turn for 1/2 of one complete turn.

BACK BURNER KNOB:

SIDE BURNER KNOB:

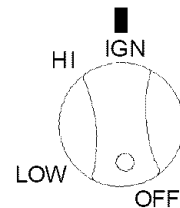
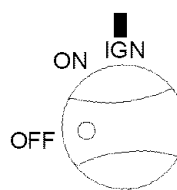

## Side Burner Lighting Instructions

1. Follow steps 1 through 5 of the Grill Lighting Instructions.
2. Open Side Burner Lid.
3. Set Control Knobs to OFF and open the LP gas tank valve **SLOWLY 1/4 of a turn**. For Natural Gas open the Shut Off Valve at source.
4. Push and turn the Control Knob to IGN. Push the Control Knob in to automatically ignite the Burner. Once the burner is lit, turn the knob back to HIGH.
5. If ignition does not occur in 5 seconds, turn the burner Control Knob(s) and gas source OFF and conduct a leak test as explained in the Use and Care section of this manual. If no leaks are detected, wait 5 minutes for any gas to clear and repeat the lighting procedure.
6. After Burner is lit, turn the tank valve **SLOWLY** one more 1/4 of a turn for 1/2 of one complete turn.

## Manually Lighting Your Grill By Paper Match

To light your Main Burner by match, follow steps 1 through 6 of the Grill Lighting Instructions. Then, light the match and place it over the top opening of the Lighting Tube. Push and turn the nearest Control Knob to the HIGH setting to release gas. The Burner should light immediately.

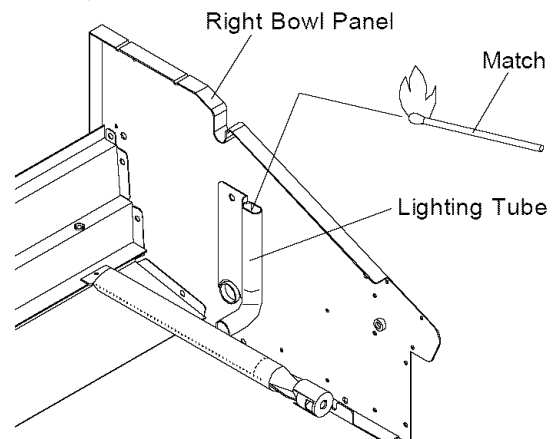

# USE AND CARE INSTRUCTIONS

## Troubleshooting

### If the grill fails to light :

1. Turn gas off at source and turn Control Knobs to OFF. Wait at least 5 minutes for gas to clear, then retry.
2. If your grill still fails to light, check gas supply and connections.
3. Repeat lighting procedure. If your grill still fails to operate, turn the gas off at source, turn the Control Knobs to OFF, then check the following:



- Misalignment of Burner Tubes over Orifices  
**Correction:** Reposition Burner Tubes over Orifices.
- Obstruction in gas line  
**Correction:** Remove fuel line from grill. Do not smoke! Open gas supply for one second to clear any obstruction from fuel line. Close off gas supply at source and reconnect fuel line to grill.
- Plugged Orifice  
**Correction:** Remove Burners from grill by removing the screw from the rear of each Burner using a Phillips Head Screwdriver. Carefully lift each Burner up and away from gas valve Orifice. Remove the Orifice from gas valve and gently clear any obstruction with a fine wire. Then reinstall all Orifices, Burners, Cotter Pins and cooking components.

If an obstruction is suspected in Gas Valves or Manifold, call the Grill Information Center.

- Obstruction in Burner Tubes  
**Correction:** Follow the Burner Tube cleaning procedure on **page 18** of this Operator's Manual.
- Misalignment of Ignitor on Burner  
**Correction:** Check for proper position of the Electrode Tip as shown in **step 3 page 10**. The gap between the Spark Electrode Tip and Spark Receiver should be approximately 3/16". Adjust if necessary. With the gas supply closed, turn any Main Burner Control Knob to IGN then push in and watch for the presence of a spark at the Electrode.
- Disconnected Electric Wires  
**Correction:** Inspect the Electric Ignitor (see Parts List) found behind the Control Panel. Connect loose Electric wires to Junction Box and try to light the grill.
- Weak AA battery  
**Correction:** Unscrew the Ignitor Cap and replace the battery.
- If the grill still does not light you may need to purge air from the gas line or reset the regulator excess gas flow device. **Note:** This procedure should be done every time a new LP Gas tank is connected to your grill.



### To purge air from your gas line and/or reset the regulator excess gas flow device:

- Turn Control Knobs to the OFF position.
- Turn off the gas at the tank valve.  
For Natural Gas shut off NG valve.
- Disconnect regulator from LP Gas tank.  
For Natural Gas disconnect regulator from 12 ft. Natural Gas Hose.
- Let unit stand 5 minutes to allow air to purge.
- Reconnect regulator to the LP Gas tank.  
For Natural Gas reconnect regulator to 12 ft. Natural Gas Hose.
- Turn tank valve on SLOWLY 1/4 of a turn.  
For Natural Gas open Shut Off valve.
- Open the Grill Lid.
- Push and turn the LEFT Control Knob to IGN.
- Push the Control Knob in to automatically ignite the Burner.

 **WARNING** 

Should a FLASHBACK fire occur in or around the Burner Tubes, follow the instructions below. Failure to comply with these instructions could result in a fire or explosion that could cause serious bodily injury, death, or property damage.

- Shut off gas supply to the gas grill.
- Turn the Control Knobs to OFF position.
- Open the Grill Lid.
- Put out any flame with a Class B fire extinguisher.
- Once the grill has cooled down, clean the Burner Tubes and Burners according to the cleaning instructions in this Operator's Manual.

 **WARNING** 

**Never** lean over the grill cooking area while lighting your gas grill. Keep your face and body a safe distance (at least 18 inches) from the Lighting Hole or Burners when lighting your grill by match.

## GRILL INFORMATION CENTER

Call 8am to 8pm CST **1-888-317-7642** Monday through Friday

## CLEANING AND MAINTENANCE

Proper care and maintenance will keep your grill in top operating condition and prolong its life. Follow these cleaning procedures on a timely basis and your grill will stay clean and operate with minimum effort.

**CAUTION:** Be sure your grill is OFF and cool before cleaning.

### Cleaning The Cooking Grids

- Before initial use, and periodically, wash your Cooking Grids in a mild soap and warm water solution. You can use a wash cloth or vegetable brush to clean your Cooking Grids.

### Cleaning The Savor Plates™

- Periodically you should wash the Savor Plates™ in a soap and warm water solution. Use a vegetable brush to remove stubborn burnt-on cooking residue. Dry the Savor Plates™ thoroughly before you reinstall them into the cooking bowl.

### Cleaning The Grease Tray and Receptacle

- To reduce the chance of fire, the Grease Draining Tray and Grease Receptacle (some models) should be visually inspected before each grill use. Remove any grease and wash Grease Tray and Receptacle with a mild soap and warm water solution.

### Cleaning the Inside of the Grill Lid

- Grease can have a tendency to build up on the inside of the Grill Lid and could drip onto deck or patio when the lid is opened. Visually inspect the inside of the Grill Lid before each grill use. Remove any grease and wash with a mild soap and warm water solution.

### Annual Cleaning of The Grill Interior

- Burning-off excess food after every cookout will keep it ready for instant use. However, at least every 3 months you must give the entire grill a thorough cleaning to minimize your risk of grease fire and keep the grill in top shape. Follow these steps:
  1. Turn all Burner Valves to the full OFF position.
  2. Turn the LP gas tank valve to the full OFF position. For Natural Gas shut off valve.
  3. Disconnect the regulator from the gas tank. Inspect the hose with regulator assembly for cracking, cuts or any other damage, and replace as necessary. Refer to the Parts List in this Operator's Manual.
  4. Remove and clean the Savor Plates™, Cooking Grids, Cooking Rack and Grill Burners.
  5. Cover each Gas Valve Orifice with aluminum foil.
  6. Brush the inside and bottom of the grill with a fiber pad or nylon brush and wash with a mild soap and warm water solution. Rinse thoroughly and let dry.
  7. Remove aluminum foil from Orifices and check each Orifice for obstruction.
  8. Check each Spark Electrode, adjusting as needed. The space between the Spark Electrode Tip and Spark Receiver should be approximately 3/16".
  9. Replace the Burners and adjust the Gas Collector Box. The edge of the collector box should be overlapping the Burner Port.

10. Replace Savor Plates™ and Cooking Grids.

11. Reconnect the gas source and observe the Burner flame for correct operation.



### Cleaning Exterior Surfaces:

Before initial use, and periodically thereafter, we suggest you wash your grill using a mild soap and warm water solution. You can use a wash cloth or sponge for this process. Do not use a stiff wire or brass brush. These will scratch stainless steel and chip painted surfaces (varies by model) during the cleaning process.

### Cleaning Exterior Stainless Steel Surfaces:

Weathering and extreme heat can cause exterior stainless steel surfaces to turn tan in color. Machine oils used in the manufacturing process of stainless steel can also cause this tanning color. After removing any protective PVC film from the Grill Lid and Control Panel use a Stainless Steel Cleaner to polish the stainless steel surfaces of your grill. Never use abrasive cleaners or scrubbers because they will scratch and damage your grill. Follow these steps for the best results.

1. Turn the LP Gas tank valve (clockwise) to the full OFF position. Disconnect the regulator and hose assembly from LP Gas tank. For Natural Gas shut off valve and disconnect the NG regulator and hose from valve. Cover exposed gas fitting with aluminum foil.
2. Remove dirt or grease using a soft cloth and polish stainless surfaces. Wipe with a soft cloth.
3. Remove aluminum foil from exposed gas fitting and allow grill to air dry before attaching the regulator and hose to your LP Gas tank, or attaching the regulator and hose to Natural Gas valve.

 **CAUTION** 

**Failure to comply with these instructions may result in a hazardous situation which, if not avoided, may result in injury.**

Keep grill area clear and free from combustible materials, gasoline and other flammable vapors and liquids.

Do not obstruct the flow of air for combustion and ventilation.

Keep the ventilation openings of the tank enclosure cabinet free and clear of debris.

Visually check burner flames occasionally to ensure proper flame pattern as shown below.

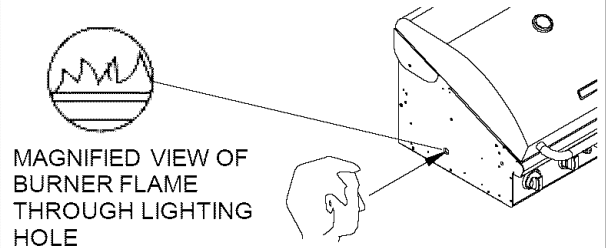

MAGNIFIED VIEW OF  
BURNER FLAME  
THROUGH LIGHTING  
HOLE

## CLEANING THE BURNER TUBES AND BURNER PORTS

To reduce the chance of **FLASHBACK FIRE** you must clean the Burner Tubes as follows at least once a month in summer and fall or whenever spiders are active in your area, and if your grill has not been used for an extended period of time.

1. Turn all Burner Valves to the full OFF position.
2. Turn the LP Gas tank valve to the full OFF position. For Natural Gas shut off NG valve.
3. Detach the LP Gas regulator assembly from your gas grill. For Natural Gas detach NG regulator from your grill.
4. Remove the Cooking Grids, Savor Plates™ and Grease Trays from your grill.
5. Remove the screw from the rear of each Burner using a Phillips Head Screwdriver.
6. Carefully lift each Burner up and away from the Gas Valve Orifice.
7. Check and clean burner/venturi tubes for insects and insect nests. A clogged tube can lead to a fire beneath the grill.
8. Refer to **Figure 1** and perform one of these three cleaning methods:

- METHOD 1:** Bend a stiff wire or wire coat hanger into a small hook as shown and run the hook through the Burner Tube and inside the Burner several times to remove debris.



- METHOD 2:** Use a bottle brush with a flexible handle and run the brush through the Burner Tube and inside the Burner several times to remove any debris.
- METHOD 3:** Use an air hose to force air through each Burner Tube. The forced air should pass debris or obstructions through the Burner and out the Ports.

Regardless of which Burner cleaning procedure you use, we recommend you also complete the following steps to help prolong Burner life.

1. Use a fiber pad or nylon brush to clean the entire outer surface of each Burner until free of food residue and dirt.
2. Clean any clogged ports with a stiff wire, such as an open paper clip.
3. Inspect each Burner for damage (cracks or holes) and if such damage is found, order and install a new Burner. After installation, check to ensure that the Gas Valve Orifices are correctly placed inside the ends of the Burner Tubes. Also check the position of your Spark Electrode.

!
WARNING
!

For safe operation ensure the Gas Valve Assembly Orifice is inside the Burner Tube before using your grill. See figure. If the Orifice is not inside the Burner Tube, lighting the Burner may cause explosion and/or fire resulting in serious bodily injury and/or property damage.

Gas Valve Assembly
Orifice
Burner Tube

**Figure 1**

TO CLEAN BURNER TUBE,  
INSERT HOOK AS INDICATED BY THE ARROW

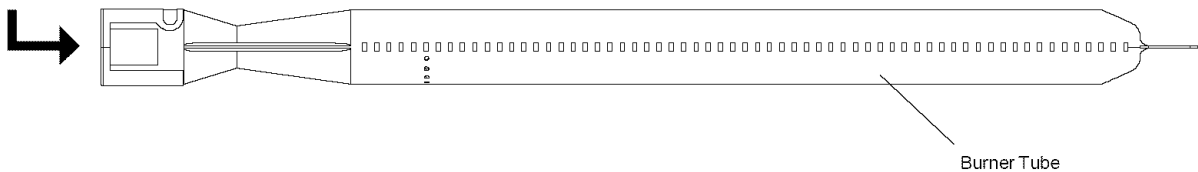

# Cooking Instructions

## Burn-Off

- Before cooking on your gas grill for the first time, you should "burn off" the grill to eliminate any odor or foreign matter. Ignite the burners, lower the Lid, and operate grill on HIGH setting for 3 to 5 minutes.

**CAUTION:** Operating your grill on the HIGH setting for longer than 5 minutes may damage certain parts of your grill. **Do not leave your grill unattended when in use.**

## Preheating

- To preheat, light your grill on HIGH, lower the Lid and follow this timetable:
  - For high temperature cooking, preheat grill 3 to 5 minutes.
  - For low temperature cooking, preheat grill 3 minutes.
  - To slow cook, preheating is not necessary.

## Cooking Temperatures

- High setting:** The HIGH Control Knob setting should only be used to pre-heat your grill the first 3-5 minutes and for burning food residue off the grill for 3-5 minutes after cooking is complete. **Never** use the HIGH setting for extended cooking.
- Medium to Low Settings:** Most recipes specify medium to low settings, including all smoking, rotisserie cooking and cooking lean cuts such as fish.

## An Important Note About Cooking Temperatures

- The suggested heat settings and cooking times shown in the following pages are approximate. Unlike the controlled environment inside your kitchen, variables including outside temperatures, direction and conditions of wind, as well as grill location will affect your grill's heat distribution. Because these conditions vary, and no two backyards are alike, we offer this guide as a convenience. We recommend you monitor your grill closely and rotate foods as needed to prevent overcooking and ensure the most delicious results every time.
- The middle and back primary cooking areas offer the highest heat for searing and grilling.
- The Secondary Cooking Rack offers medium heat for preparing breads and firm vegetables like potatoes and corn.
- The front primary cooking area offers less heat and is ideal for preparing delicate foods and for keeping cooked foods warm.

## Direct Cooking

- The direct cooking method can be used with the supplied Cooking Grids and food placed directly over the lit grill Burners. **Direct Cooking requires the Grill Lid to be open.** This method is ideal for searing, grilling, deep frying and whenever you want foods to have an open-flame barbecued taste.

## Indirect Cooking



- The indirect cooking method can also be used with the supplied Cooking Grids. To cook **indirectly**, the food should be placed on the left or right side of your grill with the Burner lit on the opposite side. Or place your food on the Secondary Cooking Rack and light the outer grill Burners. Either way, **indirect cooking must be done with the Lid down.**

## Prepare Cooking Grids for Grilling

- Greasing the cooking surface will help keep foods from sticking during the cookout and reduces the amount of cleanup required. Use a brush to apply a thin layer of cooking oil or vegetable shortening onto each Cooking Grid before each cookout. We do not suggest spray type oils unless they are specified for high-temperature cooking. Be sure to coat the entire cooking surface including edges and any areas with chipped porcelain.

## Flare-Ups

- The fats and juices dripping from grilled food can cause flare-ups. Since flare-ups impart a favorably distinctive taste and color to food cooked over an open flame, they should be accepted up to a point. To minimize flare-ups use a drip pan under foods that produce a lot of grease, like ribs.

 **WARNING** 

- Failure to comply with these instructions could result in a fire or explosion that could cause serious bodily injury, death or property damage.
- **Never** line the bottom of the grill housing or Savor Plates™ with aluminum foil, sand or any substance that will restrict the flow of grease into the Grease Draining Tray and Receptacle.
- **Before each use of your grill:** Pull out the Grease Tray and remove all grease and food debris to prevent grease fire hazard.
- **Use your grill at least 3 feet away from any wall or surface.** Use your grill at least **3 feet away** from combustible objects that can melt or catch fire (such as vinyl or wood siding, fences and overhangs) or sources of ignition including pilot lights on water heaters and live electrical appliances.
- **Never** use your gas grill in a garage, porch, shed, breezeway or any other enclosed area.
- **Your grill will get very hot.** Always wear a flame retardant BBQ Mitt when cooking on your grill. Never lean over cooking areas while using grill. Do not touch cooking surfaces, Lid, grill housing or other parts while grill is in operation, or until the grill has cooled down after use.

# Guide to Grilling using the Direct Cooking Method

## Grilling Steak and Ribs

Turn the grill Burners on HIGH, close the Lid and preheat your grill 3 to 5 minutes. Open Lid and place the meat on the Cooking Grid directly above the lit Burners. Cook the meat on both sides until seared. Reduce the heat to MEDIUM and cook meat until done. Grilling times will vary according to meat thickness.

## Grilling Hamburgers and Sausages

Turn the grill Burners on HIGH, close Lid and preheat your grill 3 to 5 minutes. Open Lid and place the meat on the Cooking Grid directly above the lit Burners. Cook the meat on both sides until seared. Reduce the heat to MEDIUM and cook the meat until done. Grilling times will vary according to meat thickness.

## Grilling Poultry

Turn the grill Burners on HIGH, close Lid and preheat your grill 2 to 3 minutes. Then raise the Lid, reduce heat to MEDIUM and cook poultry directly over lit Burners until done. Poultry skin is fatty so you should expect some flare-ups when using this direct method.

To minimize flare-ups, try grilling poultry using the indirect method. Place the poultry on one side of the grill with the opposing Burners on MEDIUM heat, and lower the grill Lid. Grilling times will vary based on the size of your poultry.

## Grilling Pork

Turn Burners on HIGH and preheat your grill 3 to 5 minutes with the Lid closed. Raise Lid, place pork on Cooking Grid and cook until seared. Reduce heat to MEDIUM and cook until done. Grilling times will vary according to meat thickness.

## Whole Fish and Whole Fillets

Preheat your grill on HIGH for 2-3 minutes with the Lid down. Raise lid and turn Burners to MEDIUM heat. Place fish (skin down) on grill and cook over direct heat until done. Use cooking time as a guide or until fish is opaque but still moist.

## Smaller Fish Fillets and Cubes

Follow the directions from above, using approximate cooking times shown at right. Place a small piece of aluminum foil on the Cooking Grids if the fish pieces are small enough to drop between the Cooking Grids.

## Vegetables and Fruit

Prepare your fruit or vegetables and brush with butter or basting sauce if desired. To cook **indirectly**, the food should be placed on the left or right side of your grill with the Burner lit on the opposite side and the grill lid down. Or center your food on the Secondary Cooking Rack and light the outer grill Burners. Either way, **indirect cooking must be done with the Lid down.**

In some instances, you may want to grill vegetables and fruit **directly** over the heat, using the supplied Cooking Grids. Foods that work best with direct heat are relatively soft and require a short cooking time: mushrooms, zucchini, tomatoes and skewered fruit such as apricots, peaches, pineapple, strawberries and kiwis. Remember the **Grill Lid must remain up when cooking directly.**

## Cut of Meat

T-bone steak  
Sirloin steak  
Beef spare ribs  
Porterhouse steak  
New York strip steak

Hamburgers  
Sausages

Chicken breast  
(cook with bone down)  
Chicken wings  
Drumsticks

Whole bird  
(cook with breast up)

Chops  
Loins  
Cutlets

Whole fish  
Whole fish fillets

Fish fillets  
Boneless cubes

## Approximate Cooking Times

**Rare:** 4-8 minutes  
**Medium:** 10-14 minutes  
**Well done:** 15-20 minutes

**Rare:** 4-6 minutes  
**Medium:** 8-10 minutes  
**Well done:** 10-15 minutes

**Direct method:**  
approximately 15 minutes  
**Indirect method:**  
up to 30 minutes

**Indirect method:**  
approximately 1 hour

**Medium:** 10-14 minutes  
**Well done:** 15-20 minutes

10 - 12 minutes per pound or until fish is opaque

4 - 5 minutes each side or until fish is opaque

For very firm vegetables—particularly potatoes and yams, we recommend that you partially boil until almost cooked, before placing them on the grill. Cooking times using the **indirect method** with the lid down will be similar to those for your kitchen oven. However, there are many factors such as outside temperature, wind conditions and location of grill that affect your grill performance so we suggest you watch the temperature gauge and adjust the heat accordingly.

Cooking times for foods prepared with the **direct method** will be much shorter mainly because of the direct heat source and softness of the food. Timing will be comparable to normal pan frying or grilling.

# Guide to Slow Roasting and Baking Techniques

## An Important Note About Heat Settings

The suggested heat settings shown are approximate. There are many factors such as outside temperature, wind conditions and grill location that affect your grill performance. We offer these cooking times as a convenience, but suggest you watch the temperature gauge and adjust the heat accordingly.

## Preparing to Roast

Roasting uses the **indirect cooking** method. Therefore, the food should be placed on the left or right side of your grill with the Burner lit on the opposite side. You can also use the supplied Cooking Grid with an aluminum drip pan underneath allowing you to collect juices for making gravies. Remember, indirect cooking requires the Lid of your grill to be down.

Preheating your grill is not required for slow cooking methods such as roasting. If you do choose to preheat your grill before roasting, turn the Burners on HIGH and close Lid for approximately 2-3 minutes.

## Food preparation

Trim meat of excess fat. Truss meat and poultry with cooking string to retain shape if desired. Bacon strips can be used to cover the outside surface of lean meat and poultry to help prevent it from drying out. Another method for keeping food moist during roasting is to put water in a cooking pan, then cover with foil. The foil should be removed for the first or the last part of the cooking time to ensure proper browning.

## Tips for roasting

Except when roasting with water in a roasting pan, the juices that collect in the pan can be used as the base for a tasty sauce or gravy. Place a cooking pan directly over the heat, add extra butter if needed, then add several spoonfuls of flour to thicken sauce. Finally, add sufficient chicken or beef stock to obtain the desired consistency.

Once the meat is cooked, remove it from your grill and cover with a piece of foil. Allow it to stand for 10-15 minutes which allows the juices to settle. This will make carving easier and ensure a tender, juicy roast.

Type of Food	How Cooked	Approximate Cooking Times
Beef	Rare	18 minutes per pound
	Medium	23 minutes per pound
	Well done	27 minutes per pound
Lamb	Medium	18 minutes per pound
	Well done	23 minutes per pound
Veal		27 minutes per pound
Pork		30-33 minutes per pound
Chicken		20-25 minutes per pound
Duck		25 minutes per pound
Fish		10 minutes per pound
Turkey, under 16 pounds		20-25 per pound + 30 minutes
Turkey, over 16 pounds		18-23 per pound + 15 minutes

## BAKING TECHNIQUES

From casseroles and cornbread to delicious desserts like fondue fruit skewers or crumb cake, baking on the grill is as easy as baking in the kitchen.

## Preparing to Bake

To bake in your new grill you'll need a baking dish or cast-iron cooking pan, and a pair of flame retardant BBQ Mitts. If the cooking pan is cast-iron be sure to season the pan before use.

Preheat your grill 3-5 minutes, then lower heat to achieve the baking temperature desired. Baking uses the **indirect cooking** method. Therefore, your cooking pan should be

placed on the left or right side of your grill with the burner lit on the opposite side.

## Tips for Baking

Prepare your favorite recipe as you would in the kitchen. Foods cooked in the grill for long periods of time should always be covered in aluminum foil to retain moisture. You will need to stir the food several times as it bakes, and add additional liquid if required.

Watch the temperature, and adjust to cook according to your recipe directions.

## Oven Temperature

Slow	300° - 340° F
Moderate	355° - 390° F
High	410° - 480° F

## Recommended Grill Setting

Both outside Burners on LOW
1 outside Burner on HIGH and 1 outside Burner on LOW
Both outside Burners on HIGH

## Guide to Rotisserie Cooking

### Slow Cooking with a Rotisserie

A Rotisserie Kit is made to fit your grill model. Rotisserie cooking produces foods that are moist, flavorful and attractive. The optional rotisserie system is most commonly used for cooking meat or poultry and is designed to cook food slowly. You can place a cooking pan beneath the food to collect juices for basting and gravy. To flavor the contents of the cooking pan you may add herbs, onions, or other spices of your choice.

The cooking times on a rotisserie will be approximately the same as for oven cooking.

### Balancing the Food

In rotisserie cooking, balancing the food is of utmost importance. The rotisserie must turn evenly or the stopping and starting action will cause the food to cook unevenly and possibly burn the heavier side.

The easiest foods to balance are those of uniform shape and texture. To test if the food is balanced correctly when secured, place the ends of the rotisserie spit loosely in the palms of your hands. If there is no tendency to roll, give the spit a quarter turn. If it is still stable, give it a final quarter turn. It should rest without turning in each of these positions. It can then be attached to your grill.

### Food Preparation

When preparing poultry, truss the birds tightly so that wings and drumsticks are close to the body of the bird. The cavity of the bird may be stuffed prior to this. Pull the neck skin down and, using a small skewer, fix it to the back of the bird. Push the rotisserie spit through lengthwise, catching the bird in the fork of the wishbone. Center the bird and tighten with the holding forks. Test the balance as described before.

A rolled piece of meat requires the rotisserie skewer to be inserted through the center of the length of meat, then secured and balanced.

For meats that contain bones, it is best to secure the rotisserie skewer diagonally through the meaty sections. If protruding bones or wings brown too quickly, cover with pieces of foil.

## Guide to Smoking

### Preparing to Smoke

Smoking gives food a distinctive, delicious flavor. You will find a variety of wood chips or pellets available for use in smoking grilled foods. Pre-soaking of wood chips may be required so read and follow the manufacturers instructions for preparing smoking chips prior to use.

**Note:** It is our experience that many smoking chip and pellet products do not actually produce a smoke but instead infuses the food with flavor. Please read product labels carefully and if in doubt, ask your retailer for details.

### Using A Smoker Box

There are many optional smoker boxes available for purchase. Follow these guidelines and always refer to the label of your smoking chips or pellets for specific directions.

Raise your Grill Lid and light the grill. Lower the Grill Lid allowing your grill to reach the desired cooking temperature for the food you are grilling. Fill your smoker box with your prepared smoking chips or pellets. Dried herbs and spices may also be added to produce different flavors. Wear a flame retardant BBQ Mitt and place your smoker box on a Cooking Grid or Savor Plate™ directly above a lit grill Burner. The heated smoking chips or pellets will flavor your foods.

### Tips for Smoking

You can reduce the strength of the smoke flavor by only smoking for half or three quarters of the cooking time. The heat required for smoking is normally LOW to MEDIUM.

Foods naturally high in oils lend themselves well to smoking, while drier foods benefit from a marinade.

- **Tuna steaks**, marinated in Asian flavors of sesame oil, soy sauce and sherry.
- **Pork fillets**, rubbed with ginger, orange rind and brushed with maple syrup.
- **Mussels**, brushed with lemon rind and chili oil.
- **Lamb cutlets**, marinated in virgin olive oil, lemon, oregano and black pepper. The same marinade can be used for a whole leg or rack of lamb.
- **Chicken**, boneless chicken pieces—especially sliced breasts.
- **Fish**, sliced fillets of firm fish, assorted seafood such as prawns, scallops and calamari.
- **Pork**, sliced fillets, diced or minced pork, sliced leg steak, sliced chops.
- **Beef**, sliced fillet, rib-eye, round, rump, sirloin.
- **Lamb**, sliced fillet, round, loin.

## Guide to Stir-Frying and Deep-Frying

### STIR-FRYING TECHNIQUES

This method of cooking is popular around the world and can be easily accomplished outdoors on your gas grill. It's a quick and healthful way of preparing a complete meal using meat, poultry or seafood in infinite combinations with other interesting ingredients like vegetables, rice or noodles.

#### Preparing to Stir-fry

Although it is possible to stir fry in other dishes, a wok is your best tool. Its high sides enable the cook to stir food without spillage. Its construction allows you to cook quickly at high temperatures, with instant control of heat which is essential for successful stir frying.

#### Food preparation

Slice meat and poultry into long thin strips and cube fish fillets. Remove all fat from meat and poultry and cut large vegetables into even slices or cubes.

Marinate foods for extra flavor and tenderness. Marinating times will vary for red meat, fish and or various cuts. Less tender cuts of meat should be marinated longer. Remember to always chill marinating food in the refrigerator prior to cooking.

Stir-fry meats, poultry or fish first. Next, add hard vegetables like carrots. Then continue with softer vegetables like snowpeas and peppers. To ensure even cooking, continually stir and toss the food in the wok using a wooden spoon or spatula.

#### Tips for Stir-frying

Place a wok on a Cooking Grid or Side Burner directly over a HIGH heat. Add only a small amount of food at a time to ensure fast cooking and also to allow the wok to reheat between ingredients.

### DEEP-FRYING TECHNIQUES

A wide variety of foods can be deep-fried outdoors on your grill, from potatoes, to seafood and chicken. Deep-frying uses a large portion of oil, preferably saturated. The outdoor location is ideal for deep-frying as smoke, grease and smells disperse in the open air instead of collecting on the ceiling of your kitchen.

#### Preparing to Deep-fry

Deep-fry on your grill using a cooking pan or wok, over direct heat.

Fill a cooking pan no more than half full of vegetable or corn oil. Start with LOW heat, then raise the heat gradually. Check the temperature of the oil carefully with a frying thermometer or test with a cube of bread. The cube of bread should brown in about 30 seconds for most cooking needs. A temperature between 350 and 400 degrees is optimal for preparing the majority of deep-fried foods.

#### Food Preparation

Foods being deep-fried taste better when coated with either batter or breadcrumbs to add flavor and prevent moisture from escaping.

#### Tips for Deep-frying

Wear a flame retardant BBQ Mitt and slowly lower foods into the hot oil using a wire scoop or stainless steel tongs. Add only a small quantity of food to the oil, allow it to cook, then repeat with another small quantity. This ensures the oil doesn't drop in temperature. Once the food is cooked, remove it carefully and drain onto a paper towel. Turn the heat off as soon as you have finished deep-frying and allow your pan to cool. When the oil is cool, remove all remnants of fried foods by straining it through a fine metal sieve, and store it in a clean bottle for future use.

## Guide to Using the Cooking Rack

Vegetables are generally easy to cook on the grill. The Cooking Rack makes it convenient because you can still use the main cooking area while the vegetables are suspended above the grids.

Pre-cook hard vegetables by briefly boiling or microwaving them before cooking on the grill. Wrap vegetables in a double thickness of foil to protect them while cooking on the grill. Then, remove the foil if desired, 10-15 minutes before the end of cooking, brush vegetables with butter or oil and finish cooking.

The Cooking Rack can be used for purposes other than just the obvious. Consider using the rack for warming French bread, garlic bread, croissants or even bagels.

A small whole fish wrapped in foil also cooks well on the Cooking Rack. Parcels of seafood such as scallops, prawns and sliced fish fillets prepared in a sauce and portioned into small foil wraps cook well this way, too.

## Don't Forget Your Grill Accessories



Accessory fit will vary by grill model and may differ from photo shown

**Anything you enjoy cooking indoors can be prepared outdoors as well.** These optional accessories make it easy to use your new Kenmore Premium or Kenmore Elite grill as an outdoor kitchen.

Not all locations will carry all items and availability is limited to supplies on hand. Accessory fit will vary by grill model so ask a sales associate for specific details.

Grill accessories are offered at most larger Sears full line stores, Sears Grand, Sears Hardware, The Great Indoors, Orchard Supply Hardware and sears.com.

A Rotisserie Kit is made to fit your grill model. Rotisserie cooking produces foods that are moist and flavorful because the slowly rotated food self-bastes to seal in meat's natural juices. The Rotisserie Kit can be used to slow cook foods using the indirect cooking method or an infrared back burner, a feature available on select models.

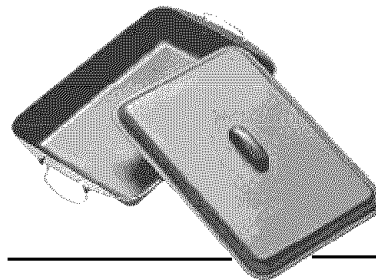

Versatile cast-iron Pan and Lid set is ideal for preparing deep dish pizza, cornbread, casseroles and deserts.

Reversible cast-iron Griddle offers a flat side for grilling breakfast, fish and fajitas and a ribbed side for cooking bacon, sausages and burgers.

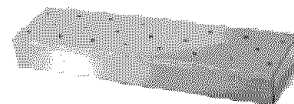
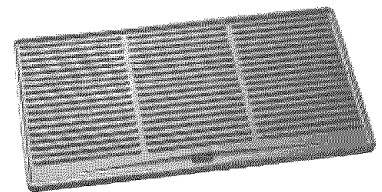

Load this Smoker Box with your favorite chips and add flavor to grilled foods.

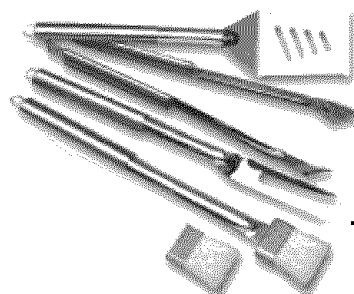

Quality 304 grade stainless steel grill tools offer long reach handles for easier outdoor cooking.

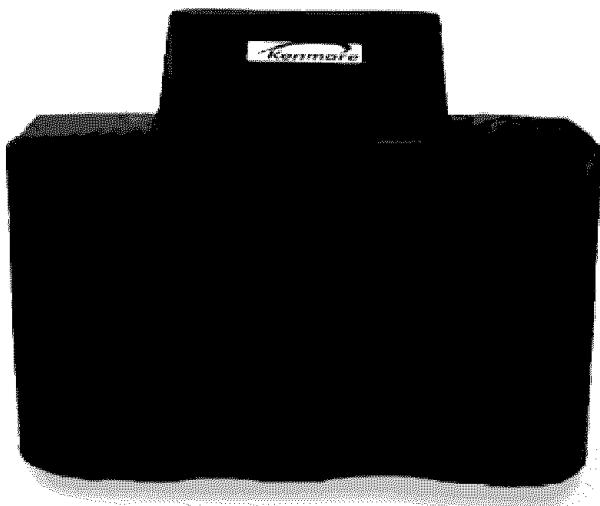

Protect your grill from rain, snow and seasonal debris with a quality made grill cover. Fit varies by grill model.

**Question:**

**Can I convert my grill from one fuel type to another in other words from LPG to NG or vice versa?**

**Answer:**

No, your gas grill is manufactured to exact specifications and is certified for LPG (Liquid Propane Gas) or NG (Natural Gas) use only. For your safety, conversion kits are not available, nor will we sell or otherwise provide parts or information to be used to convert your grill. Any attempt to convert your grill is dangerous and will void your warranty.

**Question:**

**Are the serial and model numbers of my grill listed somewhere for reference?**

**Answer:**

The serial and model numbers are listed on a silver CSA label placed on the grill. Depending on the grill model the silver CSA label will be located on the left or right side bowl panel underneath the side shelf, underneath the right side of the control panel, outside left or right of control panel or on the back of the grill cabinet.

**Question:**

**My grill will not light properly. Why?**

**Answer:**

Always light the Main Burner farthest from the fuel source first. This will draw gas across the manifold helping prevent air pockets which obstruct gas-flow and prevent proper grill lighting. Also try this procedure:

1. Turn gas off at source and turn Control Knobs OFF. Wait at least 5 minutes for gas to clear, then retry.
2. If your grill still fails to light, turn the Burner Control Knob(s) and gas source OFF and conduct a leak test of ALL gas connections and gas sources as explained in the Use and Care section of this manual.
3. If no leaks are detected, wait 5 minutes for any gas to clear and repeat the lighting procedure.

**Question:**

**If my ignitor or battery is not working how can I light my grill manually?**

**Answer:**

If your ignition fails to work or your battery needs replacing, you can light the match and place it over the top opening of the Lighting Tube. Never remove the Cooking Grids or Savor Plates™ and attempt to light the grill from above. To light your gas grill manually, follow steps 1 through 6 of Basic Lighting Procedures. Then light the match and place it over the top opening of the Lighting Tube. Turn the nearest main Burner Control Knob to the High setting to release gas. The Burner should light immediately.

**Question:**

**Sometimes I hear a humming sound coming from my regulator. What causes this? And - My grill has a low flame and sometimes will not light. Why?**

**Answer:**

The humming sound is gas flowing through the regulator. A low volume of sound is normal and will not interfere with the operation of your grill. Loud or excessive regulator humming and/or low flow and intermittent lighting may be caused by the regulator's excess gas flow device. Opening the tank valve all the way or too quickly is what triggers the regulator's safety device to restrict gas flow, preventing excess gas flow to your grill. Lighting the main Burner farthest from the fuel source every time will help eliminate air pockets in the manifold. Note: This procedure should be done every time a new LP Gas tank is connected to your grill.

- Turn all Control Knobs to the OFF position.
- Turn off the LP Gas tank at the tank valve. For Natural Gas shut off NG valve.
- Disconnect regulator from LP Gas tank. For Natural Gas disconnect regulator from 12 ft. Natural Gas Hose.
- Let unit stand for 10 minutes.
- Reconnect regulator to the LP Gas tank. For Natural Gas reconnect regulator to 12 ft. Natural Gas Hose.
- Open grill Lid (or Side Burner Lid if you are lighting the Side Burner).
- Turn the tank valve slowly ¼ of one turn. For Natural Gas open Shut Off valve.
- Light main Burner farthest from fuel source.
- Turn the tank valve slowly one more ¼ of one turn for ½ of one complete turn.
- Continue to light Burners moving towards the fuel source.
- Do not turn tank valve more than ½ of one turn on LPG models.

**Question:**

**Where do I use my grill for safer operation and better performance?**

**Answer:**

- Strong winds and low temperatures can affect the heating and performance of your gas grill so factor in these elements when positioning your grill outdoors for cooking.
- Use your grill at least 3 feet away from any wall or surface.
- Use your grill at least **3 feet away** from combustible objects that can melt or catch fire (such as vinyl or wood siding, fences and overhangs) or sources of ignition including pilot lights on water heaters and live electrical appliances.
- Never** use your gas grill in a garage, porch, shed, breezeway or any other enclosed area.
- Never** obstruct the flow of ventilation air around your gas grill housing.

**Question:**

**The Regulator and Hose supplied with my gas grill does not fit the older LP Gas tank I've used for years. Why not?**

**Answer:**

The U.S. Government regulates gas appliances and LP Gas tanks. When regulations are changed the LP Gas tank fittings are altered to insure compliance. If your LP Gas tank does not fit the Regulator and Hose supplied with your new grill, the tank is outdated and must be replaced. Note: Effective April 1, 2002 all LP Gas tanks sold must include an "OPD" Overfill Prevention Device. The OPD tanks are identified by their triangular-shaped valve wheel. This internal device prevents the LP Gas tank from being overfilled. Tanks without an OPD valve can not be refilled.

**Question:**

**What type of pipe and fittings will I need to connect a natural gas grill at my home?**

**Answer:**

Even if your home is plumbed with a natural gas connection outdoors, there is an additional fitting and piping required to hook up a natural gas grill. Refer to the Natural Gas section of this manual for a diagram of recommended Natural Gas hook-up. Because each home is unique the type and length of fittings will vary. This is a technical process that involves patience and time. The details below will offer guidance but if you feel uncomfortable with this procedure you should seek the assistance of a plumber or gas supply professional.

**Gas Line Piping:** If the length of line required does not exceed 50 feet, use a 5/8" O.D. tube. One size larger should be used for lengths greater than 50 feet. Gas piping may be copper tubing, type K or L; polyethylene plastic tube, with a minimum wall thickness of .062 inch; or standard weight (schedule 40) steel or wrought iron pipe. Copper tubing must be tin-lined if the gas contains more than 0.3 grams of hydrogen sulfide per 100 cubic feet of gas. Plastic tubing is suitable only for outdoor, underground use. Gas piping in contact with earth, or any other material which may corrode the piping, must be protected against corrosion in an approved manner. Underground piping must have a minimum of 18" cover.

**Shut Off Valve:** It is **highly recommended** that a Shut Off Valve be installed at the gas supply source outdoors. Install at a point after the gas pipe exits the outside wall and before the Quick Disconnect Hose, or install it at the point before the gas line piping enters the ground.

**Question:**

**Is it safe to clean my porcelain coated cooking grids in the dishwasher?**

**Answer:**

Clean your cooking grids by hand if there are any chips or cracks in the porcelain finish and dry them thoroughly. If no chips or cracks are present it should be safe to use the dishwasher. Remember to dry the cooking grids thoroughly before placing back onto your grill to minimize rusting.

**Question:**

**What causes grill parts to rust and what affect does it have on my grill?**

**Answer:**

Rusting is a natural oxidation process and may appear on cast-iron and steel parts. Rust will not affect the short term performance of your grill.

To slow the rusting process on steel Cooking Grids (select models) we recommend greasing the Cooking Grids before and after each cookout. Use a brush to apply a thin layer of cooking oil or vegetable shortening onto each Cooking Grid. We do not suggest spray type oils unless they are specified for high-temperature cooking. Be sure to coat the entire cooking surface including edges and any areas with chipped porcelain.

**Question:**

**Which is a better cooking surface to grill on; porcelain coated steel / cast-iron cooking grids or stainless steel grids?**

**Answer:**

They all have their advantages. For traditional grilling and searing meats, cast-iron or steel grids offer better heat conductivity. To protect against the natural rusting process, steel or cast-iron cooking grids offer a porcelain finish which requires routine maintenance to keep the grids well seasoned.

Stainless steel is popular with those who prefer less maintenance.

A new innovative solution is available on select models called stainless Therma-Core™. This Cooking Grid combines a heat conducting steel core with an easy-to-clean stainless outer shell.

**Question:**

**Some stainless steel grills specify 304 grade construction while others do not mention a grade at all? What is the difference?**

**Answer:**

All stainless grades are not created equal. The 304 grade, also called 18-8 stainless steel, is prized for its excellent resistance to rust and corrosion and good performance at high temperatures, which makes it ideal for grill construction.

304 grade stainless steel is by far the most popular stainless steel and contains 18-20% chromium and 8-10% nickel, making it non-magnetic.

Some stainless steel grills are constructed of Type 430 stainless steel which contains 16-18% chromium but generally less than 1% nickel. It is magnetic with less corrosion and rust resistance and designed for limited temperature use. Beware of stainless steel grills that offer no claim of grade because what looks shiny on the sales floor could become a problem on your patio.

How can you tell if a product is made of 304 grade stainless? Take the simple magnet test. If a magnet sticks to the stainless steel it is 430 grade. If a magnet does not stick you can trust its 304 grade quality.

# Get it fixed, at your home or ours!

## Your Home

For repair—in your home—of all major brand appliances, lawn and garden equipment, or heating and cooling systems, **no matter who made it, no matter who sold it!**

For the replacement parts, accessories and owner's manuals that you need to do-it-yourself.

For Sears professional installation of home appliances and items like garage door openers and water heaters.

**1-800-4-MY-HOME®** (1-800-469-4663)

Call anytime, day or night (U.S.A. and Canada)

[www.sears.com](http://www.sears.com)    [www.sears.ca](http://www.sears.ca)

## Our Home

For repair of carry-in items like vacuums, lawn equipment, and electronics, call or go on-line for the location of your nearest **Sears Parts & Repair Center.**

**1-800-488-1222**

Call anytime, day or night (U.S.A. only)

[www.sears.com](http://www.sears.com)

To purchase a protection agreement (U.S.A.)  
or maintenance agreement (Canada) on a product serviced by Sears:

**1-800-827-6655** (U.S.A.)

**1-800-361-6665** (Canada)

Para pedir servicio de reparación  
a domicilio, y para ordenar piezas:

**1-888-SU-HOGAR<sup>SM</sup>**  
(1-888-784-6427)

Au Canada pour service en français:

**1-800-LE-FOYER<sup>MC</sup>**  
(1-800-533-6937)  
[www.sears.ca](http://www.sears.ca)

The Sears logo is displayed in a large, bold, black serif font. The word "Sears" is written in a classic, slightly stylized font. Below the word "Sears", there is a thin, curved line that underlines the letters.

® Registered Trademark / <sup>TM</sup> Trademark / <sup>SM</sup> Service Mark of Sears, Roebuck and Co.

® Marca Registrada / <sup>TM</sup> Marca de Fábrica / <sup>SM</sup> Marca de Servicio de Sears, Roebuck and Co.

<sup>MC</sup> Marque de commerce / <sup>MD</sup> Marque déposée de Sears, Roebuck and Co.

© Sears, Roebuck and Co.