

BRINKMANN®

SMOKE 'N GRILL® *electric*

S M O K E R A N D G R I L L

COOK'N CAJUN®

ES-90 ELECTRIC SMOKER & GRILL

OWNER'S MANUAL

ASSEMBLY AND OPERATING INSTRUCTIONS

WARNING

READ AND FOLLOW ALL WARNINGS AND INSTRUCTIONS IN THIS MANUAL TO AVOID PERSONAL INJURY OR PROPERTY DAMAGE.



IMPORTANT SAFEGUARDS

WE WANT YOU TO ASSEMBLE AND USE YOUR SMOKER AS SAFELY AS POSSIBLE.

THE PURPOSE OF THIS SAFETY ALERT SYMBOL 

IS TO ATTRACT YOUR ATTENTION TO POSSIBLE HAZARDS AS YOU ASSEMBLE AND USE YOUR SMOKER.

WHEN YOU SEE THE SAFETY ALERT SYMBOL, PAY CLOSE ATTENTION TO THE INFORMATION WHICH FOLLOWS!

 **READ ALL SAFETY WARNINGS AND INSTRUCTIONS CAREFULLY
BEFORE ASSEMBLING AND OPERATING YOUR SMOKER.**

WARNING

- This smoker is to be used outdoors only. Do not operate this smoker indoors or in an enclosed area.
- Do not use this smoker in the rain or on wet surfaces. Do not immerse cord, plug or electric element in water or other liquids. Keep this smoker and all electrical appliances away from swimming pools, hot tubs, etc. Hazard of electrical shock if used on a wet surface, in the rain or if appliance has been exposed to moisture.
- For household use only. Do not use this product for other than its intended purpose.
- To prevent accidental electrical shock, this smoker should always be used on a GFCI (Ground Fault Circuit Interrupter) outlet or circuit.
- Always use a 3-wire grounded outlet wired for 120 volts which is GFCI protected at 15 or 20 amps. If in doubt, contact a qualified electrician. Do not operate this smoker with any other appliance or electrical device on the same circuit.
- The smoker is turned "ON" by plugging cord into electric outlet. There is no ON/OFF control switch. Before plugging unit into electric outlet, smoker should be completely set up with flavoring wood in place, liquid in water pan, meat on grills and dome lid on smoker. Always turn the unit "OFF" by unplugging cord from outlet when adding water and wood or when finished cooking.
- Do not use an extension cord unless absolutely necessary. If you must use one, the following care should be exercised:
 - a. Use the shortest length possible. Use a 12/3 or 14/3 grounded-type extension cord with a rating of at least 15 amps.
 - b. The cord should be marked with suffix letter "W-A" and with a tag stating "Suitable for Use with Outdoor Appliances."
 - c. Keep cord connection dry and off the ground. Appliance and/or extension cord should be placed in such a manner so it will not be tripped over, tugged on by children or pets. Do not allow cord to touch hot surfaces.
- Do not operate this smoker if:
 - a. The cord or plug is damaged.
 - b. The electric element has been damaged in any manner.
 - c. The smoker has malfunctioned.
 - d. The smoker has been exposed to moisture or if grease and drippings were not cleaned from element after each use. Refer to "Proper Care & Maintenance" section of this manual.
 - e. There is any damage to the smoker. (Return the smoker with prior return authorization number to The Brinkmann Corporation for examination, repair or replacement.)
 - f. The GFCI circuit trips when the electric element is plugged into the electric outlet.
- Proper clearance of 5 feet between the smoker and combustible construction should be maintained at all times when this product is in use.
- In windy weather, this product should be located in an outdoor area that is protected from the wind.
- Do not leave smoker unattended when in use.
- Do not place smoker on or near a gas or electric burner, or a heated oven.
- Do not store or use smoker near gasoline or other flammable liquids, gases or where flammable vapors may be present.
- Use smoker only on a hard, level, noncombustible, stable surface (concrete, ground, etc.). Never use smoker on wooden or other surfaces that could burn.
- A drip pan/ash guard will not prevent fires from occurring on a wooden or other combustible surface. A drip pan/ash guard is designed for use with a smoker for easy clean up of drippings that can cause discoloration of surface and to catch falling ashes and embers.
- Smoker should be placed in an area where children and pets cannot come into contact with unit. Close supervision is necessary when this smoker is in use.

WARNING

- Use caution when reaching into or under smoker. Always wear oven mitts/gloves to protect your hands from burns. Avoid touching hot surfaces.
- Base pan should never be touched or moved while smoker is in operation or if still hot.
- Do not wear loose clothing or allow hair to hang freely when operating smoker.
- Always wear shoes when operating smoker.
- When in operation, smoker contains hot liquid in water pan. Extreme caution should be used at all times. Do not move smoker when water pan contains hot liquids. Tilting or other slight movement could cause hot liquid to spill from water pan causing serious bodily injury.
- When lifting the dome lid, keep hands, face and body safe from hot steam or possible flame flare-ups. Always lift the dome lid off the smoker by tilting the dome lid toward you to allow hot steam to escape away from your face. Should a flame flare-up occur, replace dome lid and unplug smoker to smother flame. Do not use water to extinguish flames.
- Use extreme caution when adding liquid to water pan being careful not to spill any liquid onto electric element. Always unplug smoker before adding water. Follow instructions in "Adding Water During Cooking" section of this manual.
- Water pan should always be used when smoking. Do not allow liquid in water pan to completely evaporate. Check water pan every 2 hours and add water if level is low (a sizzling sound may indicate a need for water). Follow instructions in "Adding Water During Cooking" section of this manual.
- Use a sufficient amount of flavoring wood to avoid having to remove smoker body from base pan during the cooking process. This will limit the danger of spilling hot liquid from the water pan which could cause serious bodily injury.
- Use caution when assembling or operating your smoker to avoid cuts or scrapes from sharp edges of metal parts.
- Never add charcoal, lighter fluid, fuel or material of any kind, other than flavoring wood to the base pan where the electric element and lava rocks are housed. Place wood chunks on lava rocks away from the electric element.
- Unplug the smoker from electric outlet when not in use. Allow smoker to cool completely before cleaning. Make sure embers are completely extinguished. Dispose of remaining embers and ashes in a noncombustible container. Do not allow ashes to build up in smoker.
- Do not use the smoker if the electric element has been exposed to moisture, grease and drippings, or if there is excessive ash buildup on the lava rock. Do not clean electric element with a water spray or the like. Failure to adhere to this safety warning could result in the electric element shorting out and in some cases, exploding. Clean the electric element and lava rocks as instructed in the "Proper Care & Maintenance" section of this manual.
- Store the smoker indoors in a dry location when not in use—out of the reach of children.
- Accessory attachments not manufactured by The Brinkmann Corporation for this smoker are not recommended and may lead to personal injury or property damage.
- Use caution when lifting or moving smoker to prevent strains and back injuries.
- We advise that you have a fire extinguisher designed for use with electrical appliances on hand. Refer to your local authority to determine proper size and type of fire extinguisher.
- Do not attempt to service smoker other than normal maintenance as explained in "After-Use Safety and Proper Care & Maintenance" sections of this manual. Repairs should be performed by The Brinkmann Corporation only.
- Properly dispose of all packaging material.

USE CAUTION AND COMMON SENSE WHEN OPERATING YOUR SMOKER.

**FAILURE TO ADHERE TO SAFETY WARNING AND GUIDELINES IN THIS MANUAL COULD RESULT
IN BODILY INJURY OR PROPERTY DAMAGE.**

SAVE THESE INSTRUCTIONS

ASSEMBLY INSTRUCTIONS

⚠ READ ALL SAFETY WARNINGS & ASSEMBLY INSTRUCTIONS CAREFULLY BEFORE ASSEMBLING OR OPERATING YOUR SMOKER.

FOR MISSING PARTS, PLEASE CALL CUSTOMER SERVICE AT 1-800-527-0717.

(Proof of purchase will be required.)

Inspect contents of the box to ensure all parts are included and undamaged.

Tools required to assemble your Smoke'N Grill/Cook'N Ca'jun Electric Smoker and Grill:

- Flathead Screwdriver
- Pliers

PARTS LIST:

- ① 1 Dome Lid
- ② 1 Smoker Body
- ③ 2 15½" Chrome Cooking Grills
- ④ 1 Porcelain Water Pan
- ⑤ 1 Base Pan
- ⑥ 1 Lava Rock Pan
- ⑦ 1 Electric Element
- ⑧ 3 Upper Support Brackets (Single Clip)
- ⑨ 3 Lower Support Brackets (V Clip)
- ⑩ 1 Bag Lava Rocks
- 12 10-24 x ¾" Screws and Square Nuts

SMOKE'N GRILL HANDLE PARTS:

- ⑪ 3 Metal Brackets for Handles
- ⑫ 6 Wooden Handle Halves
- 6 8-32 x ¾" Screws and Nuts (for Handles)

OR

COOK'N CA'JUN HANDLE PARTS:

- ⑬ 3 Knob Handles
- 3 ¼-20 x ¾" Screws and Nuts (for Handles)

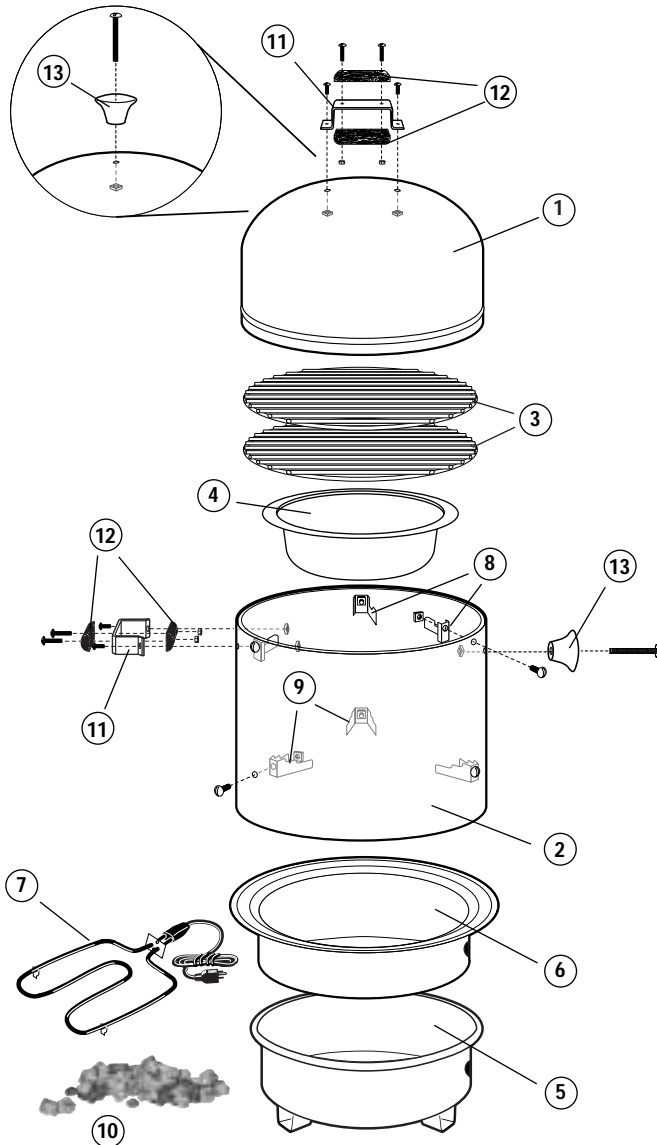

STEP 1:

Smoke'N Grill Handle Assembly & Installation

- a. Attach wooden handle halves to metal brackets using 8-32 x 3/4" screws and nuts as illustrated. Attach two handle assemblies to side of smoker body using 10-24 x 3/8" screws and square nuts as illustrated.

OR

Cook'N Ca'jun Side Knob Handle Installation

- a. Attach two knob handles to side of smoker body using 1/4-20 x 3/4" screws and nuts as illustrated.

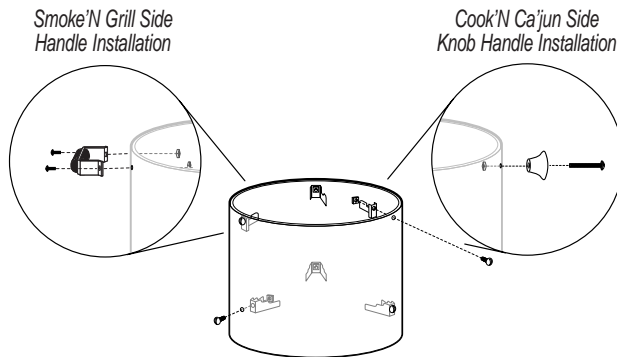

- b. Attach the three lower support brackets (V-clips) to inside of smoker body through the three 1/4" holes that are located about halfway down the smoker body (lower level). Mount each bracket with notched side facing up using 10-24 x 3/8" screws and square nuts. Tighten screws securely.
- c. Attach the three upper support brackets (single clips) to inside of smoker body through the three 1/4" holes located near the top edge. Mount each bracket with notched side facing up using 10-24 x 3/8" screws and square nuts. Tighten screws securely.

STEP 2:

- a. Place lava rock pan inside base pan and align the hole in the side of each pan.
- b. Working from the inside of the lava rock pan, feed the cord of the electric element through the aligned holes until the back plate of the electric element is resting against the wall of the lava rock pan. Empty the entire bag of lava rocks into the pan and spread evenly.
- c. Lift the electric element up and position it on top of lava rocks. Keep the back plate of the electric element flush against wall of lava rock pan.

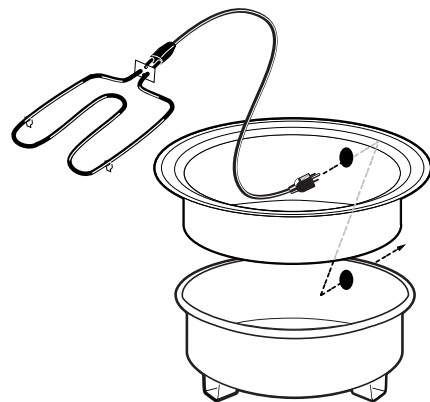
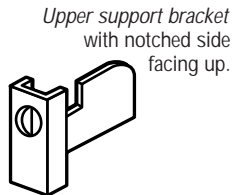
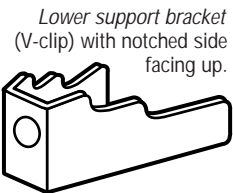
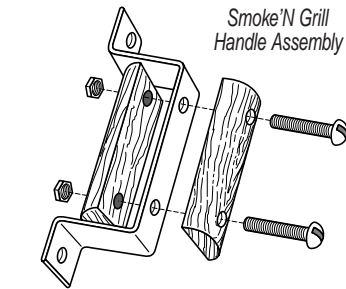

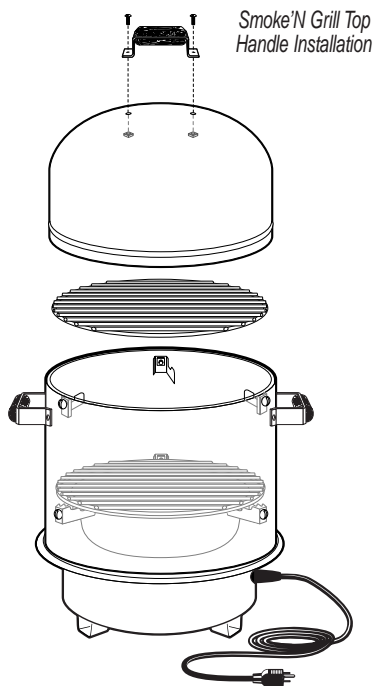

STEP 3:

- a. Place water pan inside smoker body on top of lower support brackets. Position water pan so the rim is resting securely on notched out step of all three support brackets. Place smoker body on base pan.
- b. Place a cooking grill on the lower support brackets directly above water pan.
- c. Place a cooking grill on the upper support brackets so the outer rim is resting securely on notched out step of all three support brackets.

STEP 4:

Smoke'N Grill Top Handle Installation

- a. Attach the handle assembly on top of dome lid using 10-24 x 3/8" screws and square nuts.

OR

Cook'N Ca'jun Top Knob Handle Installation

- a. Attach the knob handle on top of dome lid using 1/4-20 x 3/4" screws and nuts.
- b. Place dome lid on upper support brackets of smoker body.

NOTE: The dome lid is not designed to fit snugly in the smoker body. The gap between dome lid and smoker body allows proper air draft.

YOUR SMOKE'N GRILL/COOK'N CA'JUN ELECTRIC SMOKER IS NOW COMPLETELY ASSEMBLED.

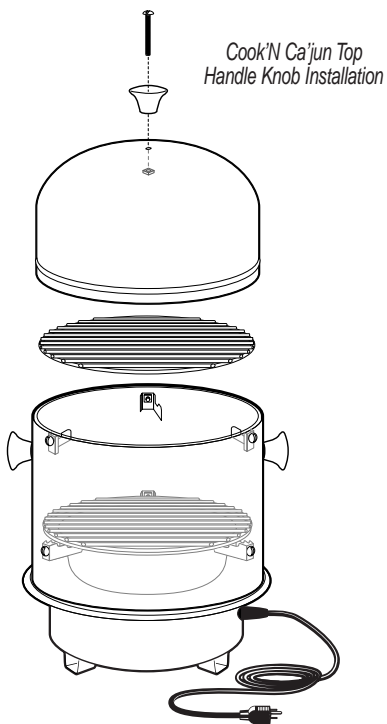

Cure your smoker before first use (see instructions on page 6). After cleaning, apply a light coat of vegetable oil or vegetable cooking spray to the interior surface of the dome lid, smoker body, cooking grills and water pan. This simple process will help reduce interior rusting. DO NOT apply oil to the base pan, lava rock pan, lava rocks or electric element.

READ ALL SAFETY WARNINGS AND OPERATING INSTRUCTIONS PRIOR TO USING YOUR SMOKER.

OPERATING INSTRUCTIONS

⚠️ PLACE THE SMOKER OUTDOORS ON A HARD, LEVEL, NON-COMBUSTIBLE SURFACE AWAY FROM ROOF OVERHANG OR ANY COMBUSTIBLE MATERIAL. NEVER USE ON WOODEN OR OTHER SURFACES THAT COULD BURN. PLACE THE SMOKER AWAY FROM OPEN WINDOWS OR DOORS TO PREVENT SMOKE FROM ENTERING YOUR HOUSE. IN WINDY WEATHER, PLACE THE SMOKER IN AN OUTDOOR AREA THAT IS PROTECTED FROM THE WIND.

⚠️ READ ALL SAFETY WARNINGS & INSTRUCTIONS CAREFULLY BEFORE ASSEMBLING AND OPERATING YOUR SMOKER.

Prior to first use, cure your smoker to minimize damage to the exterior finish as well as rid the smoker of paint odor that can impart unnatural flavors to the first meal prepared. Cure your smoker periodically throughout the year to protect against rust.

1. Remove water pan from smoker and leave out during curing process. Lightly coat all interior surfaces of the smoker, dome lid and cooking grill with vegetable oil or vegetable oil spray. Do not coat lava rock pan, lava rock or electric element.

NOTE: Do not use flavoring wood while curing your smoker.

2. With the dome lid on smoker, plug the smoker into electric outlet.

⚠️ WARNING: Always use a 3-wire grounded outlet wired for 120-volts which is GFCI protected at 15 or 20 amps. If in doubt, contact a qualified electrician. Do not operate this smoker with any other appliance or electrical device on the same circuit.

3. Cure smoker for three hours, then unplug smoker from electric outlet. Allow smoker to cool completely. It is important that the exterior of the smoker is not scraped or rubbed during the curing and cooling process.

IMPORTANT: To protect your smoker from excessive rust, the unit must be cured periodically and covered at all times when not in use. A smoker cover may be ordered directly from Brinkmann by calling 1-800-468-5252.

FOLLOW THESE STEPS BEFORE PLUGGING SMOKER INTO ELECTRIC OUTLET.

1. Remove dome lid and smoker body from base pan.
2. Place flavoring wood on lava rock near the electric element. Refer to "Flavoring Wood" section for recommended amount of flavoring wood to use.

NOTE: Do not place the flavoring wood directly on the electric element. This could cause flame flare-up and failure of the electric element.

3. Place empty water pan inside smoker body on the lower support brackets. Position water pan so rim is resting securely on notched out step of all three support brackets.

⚠️ CAUTION: Before each use, check handles and support brackets to make sure they are securely fastened.

4. Place the smoker body on base pan, making sure the water pan is still in place.

Curing Your Smoker

Smoking

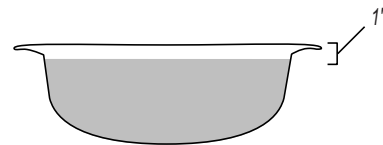

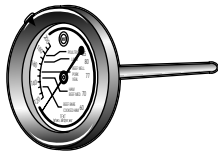
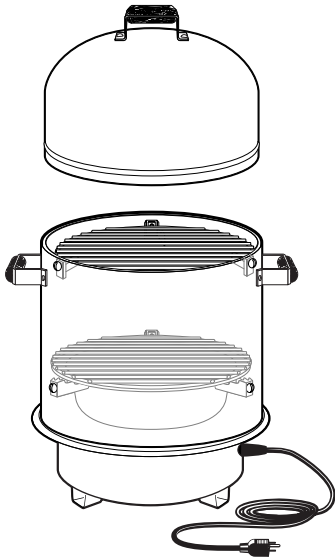

Grilling

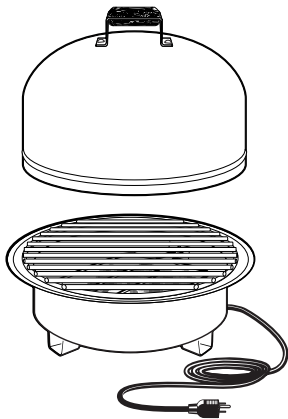

- Carefully, fill water pan with warm water or marinade to 1" below the rim. A full pan holds 4 quarts of water and will last for approximately 2-3 hours. Do not overfill or allow water to overflow from water pan.

⚠ WARNING: Do not spill water or liquid onto electric element.

- Place a cooking grill on the lower support brackets directly above the water pan.
- Place food on the cooking grill in a single layer with space between each piece. This will allow smoke and moist heat to circulate evenly around all pieces.
- Place the other cooking grill on the upper support brackets. Make sure the rim is resting securely on notched out step of all three support brackets. Place food on the cooking grill.
- With the dome lid on smoker, plug the smoker into electric outlet.

⚠ WARNING: Always use a 3-wire grounded outlet wired for 120-volts which is GFCI protected at 15 or 20 amps. If in doubt, contact a qualified electrician. Do not operate this smoker with any other appliance or electrical device on the same circuit.

- Allow food to cook. After 2-3 hours of cooking, check water level and add water if level is low. Follow instructions in the "Adding Water During Cooking" section of this manual.
- Always use a meat thermometer to ensure food is fully cooked before removing from smoker.
- After cooking, always unplug the smoker from electric outlet. Allow smoker to cool completely, then follow instructions in the "After-Use Safety and Proper Care & Maintenance" sections of this manual.

- Remove dome lid and smoker body from base pan.
- Place a cooking grill on the base pan.
- Place food on the cooking grill in a single layer with space between each piece.
- Place dome lid on base pan and plug the grill into electric outlet. For best results, the dome lid should be placed on base pan when grilling food.

⚠ WARNING: Always use a 3-wire grounded outlet wired for 120 volts which is GFCI protected at 15 or 20 amps. If in doubt, contact a qualified electrician. Do not operate this grill with any other appliance or electrical device on the same circuit.

- Always use a meat thermometer to ensure food is fully cooked before removing from smoker.

⚠ WARNING: When grilling, drippings from meat may cause flame flare-up. Use extreme caution when removing the dome lid. Lift dome lid by tilting it toward you to allow heat and flame to escape away from your face. If flame flare-ups occur, replace the dome lid and unplug the grill to smother flame. Do not use water to extinguish a grease fire.

- After cooking, always unplug the grill from electric outlet. Allow grill to cool completely, then follow instructions in the "After-Use Safety and Proper Care & Maintenance" sections of this manual.

To obtain your favorite smoke flavor, experiment by using chunks, sticks or chips of flavor producing wood such as hickory, pecan, apple, cherry, or mesquite. Most fruit or nut tree wood may be used for smoke flavoring. Do not use resinous woods such as pine as it will produce an unpleasant taste.

Wood chunks or sticks 3" to 4" long and ½" to 1" thick work best. Unless the wood is still green, soak the wood in water for 20 minutes or wrap each piece in foil and tear several small holes in the foil to produce more smoke and prevent the wood from burning too quickly. A lot of wood is not required to obtain a good smoke flavor. A recommended amount is 3-4 wood chunks or sticks. Experiment by using more wood for stronger smoke flavor or less wood for milder smoke flavor.

Additional flavoring wood should not have to be added during the cooking process, however, it may be necessary when cooking very large pieces of meat. Follow the instructions and cautions below to avoid injury while adding wood.

1. Unplug smoker from electric outlet. Remove dome lid by tilting the dome lid toward you to allow heat and steam to escape away from your face. Use caution since flames can flare-up when fresh air suddenly comes in contact with grease fire.
2. Wearing oven mitts, remove food from cooking grills, then smoker body from base pan.

⚠ WARNING: The water in water pan will be extremely HOT. When lifting smoker body from base pan, use extreme caution and make sure the water pan is securely in place on the three lower support brackets. Keep legs and feet out from under the smoker body to avoid being scalded by hot liquids spilling from water pan. Be extremely careful not to tilt or jar smoker so hot water does not spill out of water pan.

3. Set the smoker body with the water pan aside on a hard, level, noncombustible surface.
4. Stand back a safe distance and use long cooking tongs to place flavoring wood on the lava rock. Do not allow flavoring wood to come in contact with the electric element.
5. Replace smoker body with the water pan on base pan.

⚠ WARNING: The water in water pan will be extremely HOT. When lifting smoker body from ground, use extreme caution and make sure the water pan is securely in place on the three lower support brackets. Keep legs and feet out from under the smoker body to avoid being scalded by hot liquids spilling from water pan. Be extremely careful not to tilt or jar smoker so hot water does not spill out of water pan.

6. Replace food on cooking grills then place the dome lid on smoker body.
7. Plug the smoker back into electric outlet and allow food to continue cooking.

Flavoring Wood



Adding Wood During Cooking

Adding Water During Cooking

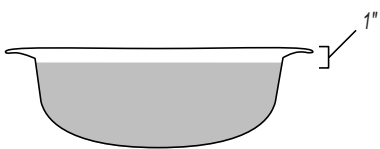

Cooking Tips

Check the water level in water pan if the complete cooking process takes longer than 2 hours. A low water level can be detected by listening for the sound of water sizzling. Water can be added to the water pan through the top of smoker or side door. Use caution and follow instructions carefully.

⚠ WARNING: Do not spill water onto the electric element.

1. Unplug the smoker from electric outlet.
2. Lift the dome lid off the smoker body by tilting the dome lid toward you to allow heat and steam to escape away from your face. Use caution since flames can flare-up when fresh air suddenly comes in contact with fire. Inspect the water level in pan.
3. If water level is low, add water to water pan. If food is on top cooking grill only, water may be added to the water pan by moving food aside on cooking grill and pouring water down through the cooking grill. Fill water pan to 1" below the rim. Pour slowly to avoid splashing or overfilling.

If using both cooking grills, wear oven mitts to remove food and the top cooking grill. Move food aside on the lower cooking grill and pour water into water pan through the lower cooking grill. Pour slowly to avoid splashing or overfilling.

4. Set the top cooking grill on the upper support brackets and place food back on the cooking grill.
5. Place the dome lid on smoker body. Plug smoker back into electric outlet and allow food to continue cooking.

-
- Variation in flavor can be achieved by adding wine, soft drinks, herbs, spices, bits of citrus peel, fruit juice, onion or marinades to the water pan.
 - Brush poultry and naturally lean meats with cooking oil, butter or margarine before cooking.
 - Meat should be completely thawed before cooking.
 - When cooking more than one piece of meat, the cooking time is determined by the largest single piece being cooked.
 - The meat bastes itself while cooking in the smoker. No basting or turning is necessary after the meat is placed on the grill. For added variety, barbecue sauce or marinade may be applied on meat before placing on grill.
 - There is very little difference in temperature and cooking time between top and bottom grill levels. When cooking different types or cuts of meat at the same time, place the meat that requires the least cooking time on the top cooking grill so that it may be easily removed first. If only one cooking grill is required, use the upper grill level for best results.
 - During the smoking process, avoid the temptation to lift dome lid to check food. Lifting the dome lid allows heat to escape, making additional cooking time necessary.
 - Always use a meat thermometer to determine the proper degree of doneness. Many variables (outdoor temperature, the number of times the dome lid is removed, proximity of food to heat source, etc.) will affect actual cooking times. When using a meat thermometer, place probe midway into the thickest part of the meat, making sure that it does not touch any fat or bone. Allow five minutes for the thermometer to register temperature properly.

AFTER-USE SAFETY

WARNING

- There is no ON/OFF control switch. Always turn the smoker "OFF" by unplugging cord from electric outlet when adding water and wood, or when finished cooking.
- Always allow the smoker and all components to cool completely before handling.
- Before smoker can be left unattended, remaining embers and ashes must be removed. Use caution to protect yourself and your property. Place remaining embers and ashes in a noncombustible metal container and completely saturate with water. Allow ashes and water to remain in metal container for 24 hours prior to disposing.
- Extinguished embers and ashes should be placed a safe distance from all structures and combustible materials.
- Cover and store the smoker indoors in a dry location, out of the reach of children.

- Wash water pan and cooking grills with hot, soapy water, rinse well and dry. Lightly coat water pan and cooking grills with vegetable oil or vegetable cooking spray.
- Clean inside and outside of smoker by wiping off with a damp cloth. Apply a light coat of vegetable oil or vegetable cooking spray to the interior surfaces of the dome lid and smoker body to prevent rusting.
- After the electric element has completely cooled, clean with a damp cloth after each use. Allow electric element to air dry outside of base pan so that all moisture evaporates completely before storing.
- Clean lava rocks and lava rock pan periodically with baking soda and water solution. Rinse well and allow to air dry thoroughly before storing.
- If rust appears on the exterior surface of your cooker, clean and buff the affected area with steel wool or fine grit emery cloth. Touch-up with a good high-temperature resistant paint.
- Never apply paint to the interior surface. Rust spots on the interior surface can be buffed, cleaned, then lightly coated with vegetable oil or vegetable cooking spray to minimize rusting.
- To protect your smoker from excessive rust, the unit must be properly cured periodically and covered at all times when not in use. A smoker cover may be ordered directly from Brinkmann by calling 1-800-468-5252.

Proper Care & Maintenance

©1998 The Brinkmann® Corporation
Dallas, Texas 75244

www.brinkmanncorp.com

ONE YEAR LIMITED WARRANTY

For one year from date of purchase, The Brinkmann Corporation warrants the Smoke'N Grill/Cook'N Ca'jun Electric Smoker against defects due to workmanship or materials to the original purchaser. The Brinkmann Corporation's obligations under this warranty are limited to the following guidelines:

- This warranty does not cover smokers that have been altered or damaged due to: normal wear, rust, abuse, improper maintenance, improper use, disassembly of parts and/or attempted repair by anyone other than an authorized employee of The Brinkmann Corporation.
- This warranty does not cover surface scratches or heat damage to the finish, which is considered normal wear.
- The Brinkmann Corporation may elect to repair or replace damaged units covered by the terms of this warranty.
- This warranty extends to the original purchaser only and is not transferable or assignable to subsequent purchasers.

The Brinkmann Corporation requires reasonable proof of purchase. Therefore, we strongly recommend that you retain your sales receipt or invoice. To obtain repair or replacement of your Smoke'N Grill/Cook'N Ca'jun Electric Smoker under the terms of this warranty, please call Customer Service Department at 1-800-527-0717 for a Return Authorization Number and further instructions. A receipt will be required. A Return Authorization Number must be clearly marked on the outside of the box. The Brinkmann Corporation will not be responsible for any smokers forwarded to us without a Return Authorization Number.

EXCEPT AS ABOVE STATED, THE BRINKMANN CORPORATION MAKES NO OTHER EXPRESS WARRANTY.

THE IMPLIED WARRANTIES OF MERCHANTABILITY AND FITNESS FOR A PARTICULAR PURPOSE ARE LIMITED IN DURATION TO ONE YEAR FROM THE DATE OF PURCHASE. SOME STATES DO NOT ALLOW LIMITATIONS ON HOW LONG AN IMPLIED WARRANTY LASTS, SO THE ABOVE LIMITATION MAY NOT APPLY TO YOU.

ANY LIABILITY FOR INDIRECT, INCIDENTAL OR CONSEQUENTIAL DAMAGES ARISING FROM THE FAILURE OF THE SMOKE'N GRILL/COOK'N CA'JUN ELECTRIC SMOKER TO COMPLY WITH THIS WARRANTY OR ANY IMPLIED WARRANTY IS EXCLUDED. CUSTOMER ACKNOWLEDGES THAT THE PURCHASE PRICE CHARGED IS BASED UPON THE LIMITATIONS CONTAINED IN THE WARRANTY SET OUT ABOVE. SOME STATES DO NOT ALLOW THE EXCLUSION OR LIMITATION OF INCIDENTAL OR CONSEQUENTIAL DAMAGES, SO THE ABOVE LIMITATION OR EXCLUSION MAY NOT APPLY TO YOU. THIS WARRANTY GIVES YOU SPECIFIC LEGAL RIGHTS, AND YOU MAY ALSO HAVE OTHER RIGHTS WHICH VARY FROM STATE TO STATE.

