

This Owner's Manual is provided and hosted by [Appliance Factory Parts](#).



Vermont Castings VCS3505 Owner's Manual

[Shop genuine replacement parts for Vermont Castings
VCS3505](#)



[Find Your Vermont Castings Grill Parts - Select From 273 Models](#)

----- Manual continues below -----

VERMONT
Castings
SIGNATURE
SERIES

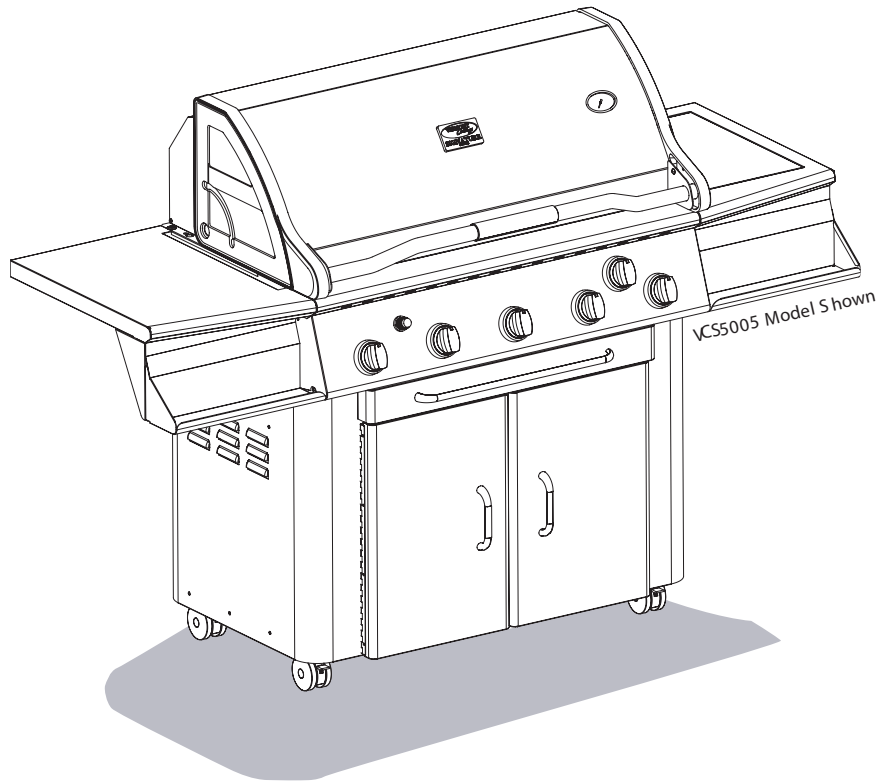

USER'S MANUAL for Models
VCS3505, VCS3505BI, VCS4005, VCS5005/5010,
VCS5005BI, VCS6005
Gas Barbecue Grill



FOR YOUR SAFETY

If you smell gas:

- **Shut off gas to the appliance;**
- **Extinguish any open flame;**
- **Open lid;**
- **If odor continues, immediately call your gas supplier or fire department.**

FOR YOUR SAFETY

Do not store or use gasoline or other flammable vapors and liquids in the vicinity of this or any other appliance.

An LP cylinder not connected for use shall not be stored in the vicinity

- **Always read and understand the WARNINGS and SAFETY INSTRUCTIONS that are contained in this Manual before attempting to use this Gas Barbecue Grill, to prevent possible bodily injury or property damage.**
- **Always keep this Manual in or near the Grill, for convenient future reference.**

SIGNAL WORDS:

The Signal Words used in this Manual, and their intended meanings, are as follows :

DANGER: Indicates that a failure to observe the safety instructions could result in death or catastrophic bodily injury.

WARNING: Indicates that a failure to observe the safety instructions could result in serious bodily injury.

CAUTION: Indicates that a failure to observe the safety instructions could result in property damage or minor bodily injury.

NOTE: Designates important information relating to the safe use of the Grill.

IMPORTANT WARNINGS:

Since this outdoor cooking appliance is movable, is fueled by natural or propane gas, generates very high temperatures for cooking and emits carbon monoxide as a by-product of combustion, prudent precautions must be taken to assure its safe use.

- **DANGER:** This Grill has been designed for OUTDOOR use only.

Never use this outdoor Grill inside any building, garage, shed or breezeway, or inside any boat, trailer or recreational vehicle, to prevent a possible fire and to prevent the possibility of carbon monoxide poisoning or asphyxiation

- **DANGER:** Exposing an overfilled or a disconnected propane cylinder to heat could cause venting of fuel through the pressure release valve. Since propane vapor is heavier than air it tends to pool and, if ignited, could produce a violent fire or explosion.

Never install a propane cylinder if it is more than 80% full, as the contents may lack adequate room for expansion when exposed to heat.

Never store a spare Propane Gas Cylinder in the cylinder compartment of this Grill, because it will be exposed to high temperatures when the Grill is in use.

This Gas Barbecue Grill will provide you with many hours of pleasure and enjoyment, if it is used in accordance with the Warnings and Safety Instructions contained in this Manual.

The essential Warnings and Safety Instructions are located throughout the pages of this Manual, but some of the principal ones have been summarized below for your convenience:

Warnings

A. SAFE LOCATIONS FOR USE OF THIS OUTDOOR GRILL

DANGER:

- Never use this outdoor Grill inside any building, garage, shed or breezeway, or inside any boat, trailer or recreational vehicle, to prevent a possible fire and to prevent the possibility of carbon monoxide poisoning or asphyxiation.

WARNINGS:

- Always confirm that this Grill is not positioned under a combustible object (e.g., an awning or umbrella) or in a covered area (e.g., a porch or gazebo) before lighting it, to prevent a possible fire.
- Always confirm that this Grill is not positioned under the overhang of a house, a garage or other structure before lighting it. An overhang will serve to deflect flare-ups and radiated heat into the structure itself, which could result in a fire.
- Always confirm that this Grill is positioned more than 36" (1 m) away from any combustible materials or surfaces before lighting it, and that no gasoline or other volatile substances are stored in the vicinity of this Grill. The temperature of a grease fire or of the radiated heat might otherwise be sufficient to ignite nearby combustibles or volatile substances.
- Always locate this Grill where there will be ample combustion and ventilation air, but never position it in the direct path of a strong wind.
- Never allow the Grill to operate while unattended, to prevent uncontrolled grease fires from erupting.

Never attempt to move this Grill while it is in operation or while it is still hot, to prevent possible personal injury.

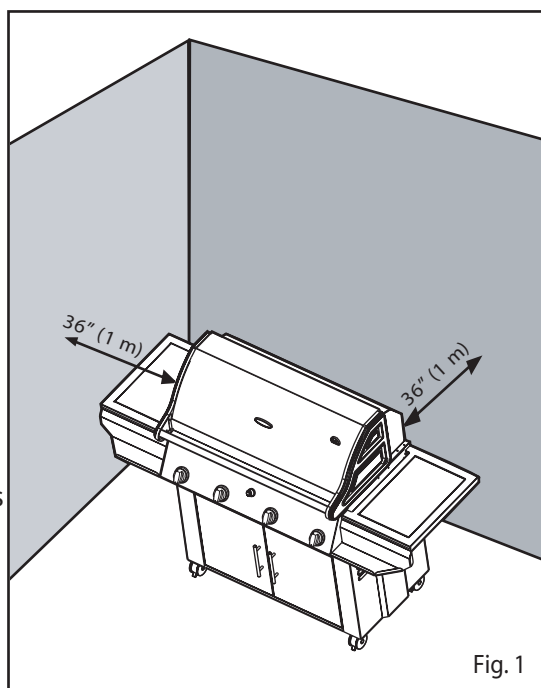

Fig. 1

- Never store or use gasoline or other flammable or volatile substances in the vicinity of this Grill or in the vicinity of any other heat-generating appliance, because of the danger of starting a fire.
- Always confirm that the installation of this Grill conforms with the requirements of all local Codes or, in the absence of any applicable local Codes, with either the National Fuel Gas Code, ANSI Z223.1/NFPA54, or CAN/CGA-B149.1, Natural Gas and Propane Installation Code.

B. SAFE USE OF LP (PROPANE) GAS**DANGER:**

- Never install a propane cylinder that is more than 80 % full, as the contents may lack adequate room for expansion when exposed to heat. Propane vapor may then be vented through the pressure release valve, which could accumulate in a pool and later result in a fire or explosion.

Always instruct your certified propane fuel supplier to confirm by weight that your cylinder is not more than 80 % full. An empty cylinder will weigh about 18 lb., while a properly filled cylinder should weigh no more than 38 lb.

- Never store a spare Propane Cylinder in the cylinder compartment of this Grill. Exposing a disconnected cylinder to heat could result in the venting of propane vapor through the pressure release valve, and the pooled vapor could result in a violent fire. (No hazard is posed by the connected cylinder if it is not overfilled, however, as it tends to refrigerate itself while it is being used.)

Always confirm that all openings in the cylinder compartment of this Grill are free of any obstructions that would restrict the circulation of ventilation air. Good ventilation will prevent the pooling of leaked propane vapor, which is heavier than air, and which could explode if ignited.

WARNINGS:

- Always consult the Rating Label on the back of the Grill to confirm which fuel must be used with the Grill. Never operate the Grill with propane gas if it has been configured to use natural gas, to prevent hazardous overheating.
- Always confirm that there are no gas leaks before lighting this Grill. Apply a 50/50 solution of liquid soap and water to the gas supply line connectors with a brush or spray bottle, and watch for bubbles. **Never use a match or open flame to test for gas leaks.**
- Always visually inspect the gas supply line for fraying, cracking or rodent damage before each use of this Grill and, if necessary, install a replacement obtained from your dealer before lighting this Grill.

Always store your spare Propane Gas Cylinders in an outdoor area that is well-ventilated, shady, cool and removed from any heat source. Always store those cylinders in an upright position. Never store a spare cylinder in the vicinity of this Grill, or in the vicinity of any other heat-generating appliance.

C. SAFE USE OF NATURAL GAS

- Always consult the Rating Label on the back of the Grill to confirm which fuel must be used with the Grill. Never attempt to operate the Grill with natural gas if it has been configured to use propane gas, to prevent possible bodily injury.
- Always employ a qualified service agency to install all necessary gas supply plumbing, for safety reasons and to assure compliance with all applicable Codes.

- Always promptly shut off the gas supply and immediately extinguish all flames if you smell gas. Always seek assistance from your gas supplier or local Fire Department if the gas smell persists, because of the danger of fire or explosion.
- Always confirm that there are no gas leaks before lighting this Grill. Apply a 50/50 solution of liquid soap and water to the gas supply line connectors with a brush or spray bottle, and watch for bubbles. Never use a match or open flame to test for gas leaks.
- Always visually inspect the gas supply line for fraying, cracking or rodent damage before each use of this Grill and, if necessary, install a replacement before lighting this Grill.
- Never permit a gas supply line to contact any heated surface of this Grill.

D. PREVENTION OF BURNS

- Always keep children and pets under close supervision when using this Grill, and never permit them to come near the Grill while it is in use, as the exterior surfaces will be very hot.
- Always wear insulated protective mitts when working at the Grill, or when attempting to close a gas supply valve after cooking has been completed, to prevent possible burns. Always use insulated pot holders when handling containers of hot food.
- Always wear an insulated protective mitt when adding a smoking agent to a Smoker Box.
- Never store or use gasoline or other flammable or volatile substances in the vicinity of this Grill, or in the vicinity of any other heat-generating appliance.

E. ELECTRICAL SAFETY

- Always confirm that this Grill has been grounded in accordance with local Codes or, in the absence of local Codes, with the National Electrical Code, ANSI/NFPA No. 70 or the Canadian Electrical Code, CSA C22.1, when an external electrical source is being utilized for the Rotisserie Motor.
- Always use a grounded three-prong outlet and a three-prong extension cord to energize the Rotisserie Motor. Never alter or remove the grounding prong on the Rotisserie Power Cord, as an electric shock hazard would then result.
- Never permit an electrical supply cord to contact any heated surface of this Grill.

Safety	Important Warnings	i - v
	Clearance Requirements	ii
	Table of Contents	1
	Fuels	2
	Safety	3
Gas Hookup	Hooking Up to the Gas Supply	4
	LP Gas Supply Connection	4
	Natural Gas Supply Connection	5
	Test for Leaks	5
Operation	Control Functions	6
	Lighting the Main Burners	7
	Turning the Burners Off	8
	Flare-ups	8
	Match Lighting the Main Burner	8
	Lighting the Rotisserie Burner	9
	Match Lighting the Rotisserie Burner	9
	Rotisserie Setup	10
	Lighting the Side Burner	11
	Shutting the Side Burner Off	11
Cooking	Methods of Cooking	12
	Preparing Food for the Grill	13
	Grilling Tips	14
	Cooking Time Chart	15
Care & Maintenance	Burners	18
	Rotisserie Burners	19
	Side Burners	19
	Cooking Grids	19
	Drip Tray	20
	Stainless Steel Panels	20
	Porcelain Enamel Castings	20
	Burner Adjustment	21
Troubleshooting Guide	22

FUELS

WARNING: Never use Natural Gas in a Grill that has been configured to burn Propane Gas, and never use Propane Gas in a Grill that has been configured to use Natural Gas, to avoid possible bodily injury. Always consult the Rating Label on the back of your Grill to confirm which fuel must be used with the Grill.

WARNING: Use only the pressure regulator and type I propane gas supply coupling and hose that is originally provided with this appliance or as specified, (see Fig. 2).

ADDITIONAL WARNINGS:

- Always install a 20 lb. propane cylinder that is equipped with a type I valve outlet (see Fig. 3), and that has a 12" diameter and an 18" height. Always use a propane cylinder that has been constructed and marked in conformance with either the specifications for LP Gas Cylinders of the U.S. Department of Transportation or the specifications in the National Standard of Canada, CAN/CSA-B339, Cylinder, Spheres and Tube for Transportation of Dangerous Goods, as applicable.
- Always confirm that your propane cylinder is equipped with a shutoff valve terminating in a Type I propane cylinder valve outlet connection, and that it has been provided with a collar to protect the cylinder valve.
- Never install a propane cylinder in this Grill unless it is equipped with a listed Overfill Protection Device (OPD).
- Always have a new propane cylinder properly purged of air by your certified propane gas dealer. Since a new cylinder is initially filled with air, the air must first be purged before it is filled with propane.
- Always visually inspect the gas supply line for fraying, cracking or rodent damage before each use of this Grill and, if necessary, install a replacement obtained from your dealer prior to lighting this Grill.

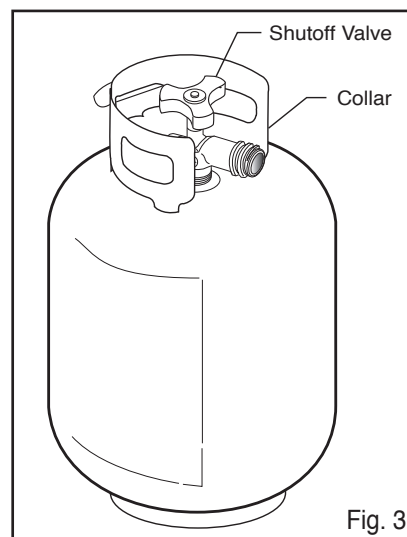
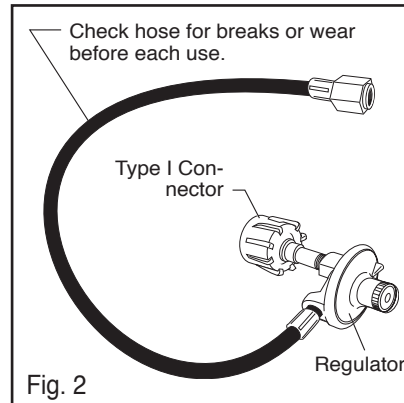

DANGER:

- a) Do not store a spare LP - Gas Cylinder under or near this appliance
- b) Never fill the cylinder beyond 80% full; and
- c) If the information in a) and b) is not followed exactly, a fire causing death or serious injury may occur.

WARNING: Always confirm that the openings in the cylinder compartment of the Grill are free of any obstructions that would restrict the circulation of ventilation air. Good ventilation will prevent any possible accumulation of leaked propane vapor, which is heavier than air and which could explode if ignited.

NOTE: Always have a certified propane gas supplier inspect and re-qualify your refillable propane gas cylinder prior to each refilling, in accordance with DOT or TC requirements for propane cylinders.

ADDITIONAL WARNINGS:

- Always handle propane cylinders with great care, as the contents are under high pressure.
- Always close the propane cylinder valve promptly after each use of the Grill.
- Always store propane cylinders outdoors, in an upright, secure position, out of direct sunlight, away from living quarters and in a well-ventilated, cool, dry area. **NEVER STORE A CYLINDER IN A BUILDING, GARAGE OR OTHER STRUCTURE OR ENCLOSED AREA.**
- Always keep cylinders out of reach of children.
- Always confirm that a valve dust cap has been tightly installed and that the valve itself is fully closed, whenever a propane cylinder has been disconnected.
- Always transport a propane cylinder in an upright, secure position, after confirming that its valve is closed.
- Always stabilize a cylinder so that it cannot move, when it is being transported in a car trunk.
- Never transport a propane cylinder in the passenger compartment of a car or truck.
- Never store a Gas Grill indoors, unless the propane cylinder has first been disconnected and removed from the Grill.
- Never expose a propane cylinder to any heat source, never apply heat directly to a cylinder and never store a spare cylinder in the vicinity of this Grill.
- Never paint a propane cylinder a dark color, as this can cause the cylinder and its contents to over-heat.
- The LP cylinder must be arranged for vapor withdrawal.

Hooking Up to the LP (Propane) Gas Supply

FOR YOUR SAFETY

1. **WARNING:** Never store or use gasoline or any other volatile substance in the vicinity of this Grill.
2. **WARNING:** Never store a spare propane cylinder in the vicinity of this Grill, or in the vicinity of any other potential heat source.

LP (PROPANE) GAS SUPPLY CONNECTION

1. Always place the propane tank in the tank locator hole in the bottom pan of the cylinder compartment.
2. Always confirm that all burner control knobs are in the OFF position before activating the gas supply.
3. Always connect the gas supply regulator as follows:
 - Insert the nipple of the valve coupling into the tank valve and tighten the connection collar by turning it clockwise with one hand while holding the regulator with the other (see Fig. 4).

WARNING: Always conduct a leak test before lighting the Grill, to prevent a possible fire or explosion (see page 5).

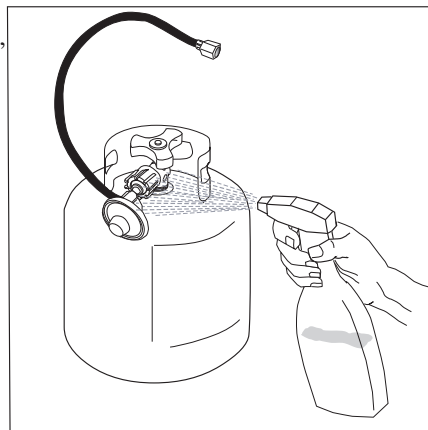
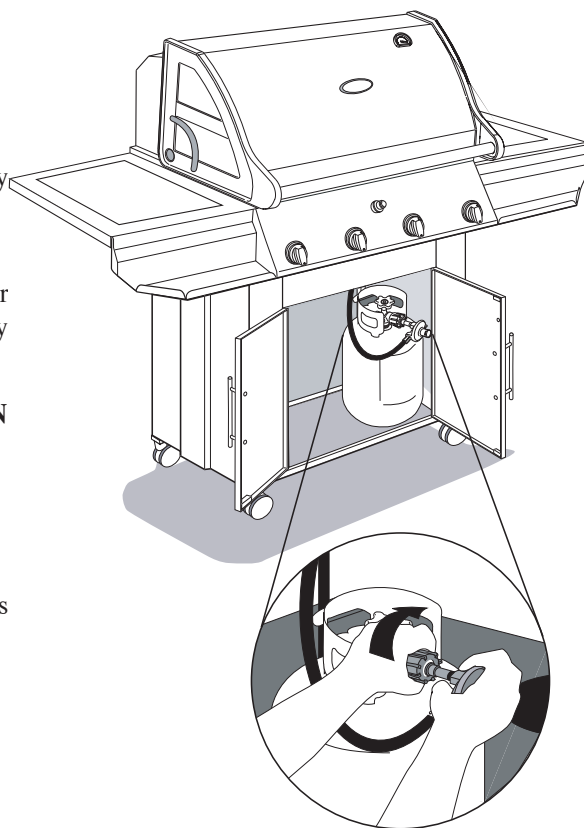
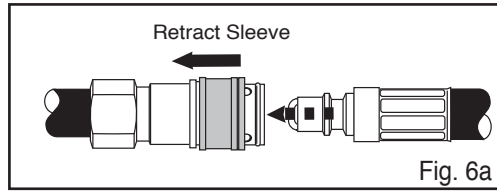

Fig. 5

Natural Gas Supply Connection

TO CONNECT:

1. Push back the Sleeve on the Socket as shown below (see Fig. 6a).
2. Insert Plug and release the Sleeve (see Fig. 6b).
3. Push the Plug until Sleeve snaps forward to lock the Plug in the Socket.



- **WARNING:** Always conduct the following safety tests before lighting the Grill, to prevent a possible fire or explosion (see leak test below).

TO DISCONNECT:

1. Push Sleeve back and pull the Plug out.

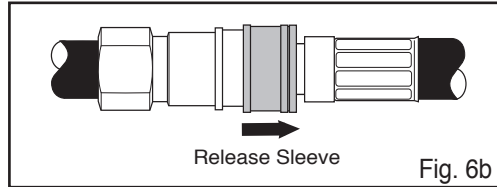

TESTING FOR GAS LEAKS

Before attempting to operate this Grill :

1. Always confirm that all burner control knobs are in the OFF position.
2. Always connect the gas supply hose first and then open the gas shutoff valve.
3. Always use a brush or spray bottle to apply a 50/50 solution of liquid soap and water to all connection points (see Fig. 5) to test for gas leaks. Never use a match or open flame for that purpose.
4. Always look for bubbles to appear, as the appearance of bubbles will indicate a gas leak. Always turn off the gas immediately and tighten the connection, if you find that a leak exists.
5. Always repeat this procedure until no further gas leaks are found to exist, before lighting the Grill.
6. Never attempt to light this Grill, however, if a leak cannot be stopped. Always call your gas supplier promptly to obtain assistance.

WARNINGS:

- Always consult the Rating Label on the back of the Grill to confirm that it has already been configured to burn Natural Gas.
- All gas supply plumbing should be performed only by a qualified service agency. In the U.S., the supply connection must be made in accordance with local code or, in the absence of local codes, with the national fuel gas codes, ANSI Z223.1/NFPA54. In Canada, the supply connection shall be carried out in accordance with the provincial authorities having jurisdiction and in accordance with the requirements of the CAN/CGA 1-B149.1 installation code. A shutoff valve must be installed between the gas grill and the main supply. For natural gas, use a $\frac{3}{8}$ " or $\frac{1}{2}$ " natural gas supply line capable of an input of at least 75,000 BTUs.
- Always disconnect the Grill and close its individual manual shutoff valve, when conducting pressure tests of the gas supply piping system at pressures which exceed 1/2 psi (3.5 kPa).
- Always isolate the Grill from the gas supply piping system by closing its individual manual shutoff valve.

Operation

Control Functions

PROPANE TANK VALVE

WARNING: Never open the Tank Valve unless the Grill is being prepared for use, to prevent the pooling of propane vapor.

Always open the Valve immediately before lighting the Grill, and always close it immediately after cooking has been completed.

BURNER CONTROL VALVES (see Fig. 7)

On Model VCS3505, three valves independently control gas flow to each burner, as indicated on the front Control Panel.

On Model VCS4005, four valves independently control gas flow to each burner, as indicated on the front Control Panel.

On Model VCS5005/5010, there are five independent control valves for the main burners, and a separate control valve for the rotisserie burner.

On Model VCS6005, there are six independent control valves for the main burners, and a separate control valve for the rotisserie burner.

The OFF position is indicated above each knob. A full range of flame adjustment is available from High to Low, (by turning a knob counterclockwise).

Activating the Igniter

ELECTRONIC IGNITION SYSTEM

As you push and hold the Igniter Button, you will hear a series of clicks as the igniter module generates an ignition spark to the burners. The burner should light within five seconds. Depending on which model you have, the system is powered by either a single "AA" or a single "AAA" battery. To remove or replace the battery, turn the push button knob counter-clockwise, and carefully pull out the spring and battery. Ensure that the positive end of the battery is in the down (bottom) position before replacing the knob.

PIEZO IGNITION SYSTEM

As you turn the Igniter Knob clockwise, you will hear a click as the Piezo module generates an ignition spark to the burner. Rotate the Igniter Knob until the burner lights. The burner should light within five seconds.

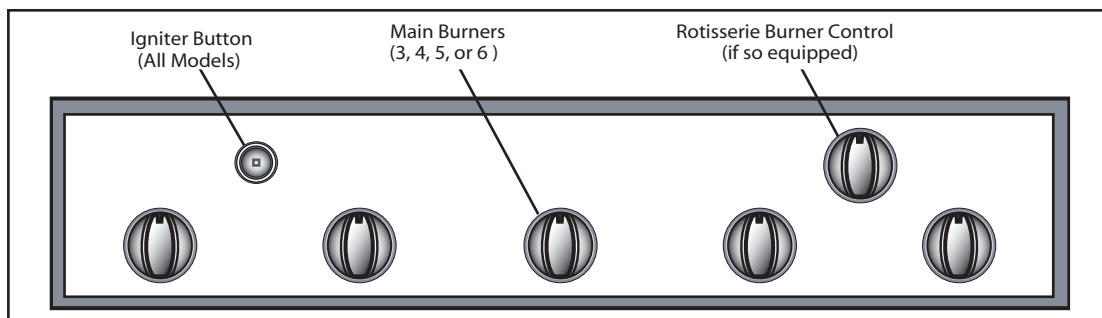

(VCS5005/5010 Model Shown)

Lighting the Main Burners

1. Always open the Hood completely and always inspect the Grill and burners to confirm that all components are properly positioned before lighting the main burners.

WARNING: Never stand with your head directly over the Grill when preparing to light the main burners, to prevent possible bodily injury.

2. Always confirm that all of the burner control knobs are in the OFF position before opening the gas supply.
3. Turn on the propane gas supply valve at the tank (1 to 2 turns) or turn on the main natural gas supply valve (see Fig. 8).
4. Turn the selected Burner Control Knob to the HIGH position by pushing down on the knob and turning it counter-clockwise.
5. Immediately activate the Igniter (see Page 6). The selected burner should light within five seconds. Light the burners sequentially from either left to right or right to left.

NOTE: When lighting the grill for the first time, burn with the main burners on HIGH for at least 30 minutes, to burn off any manufacturing residues.

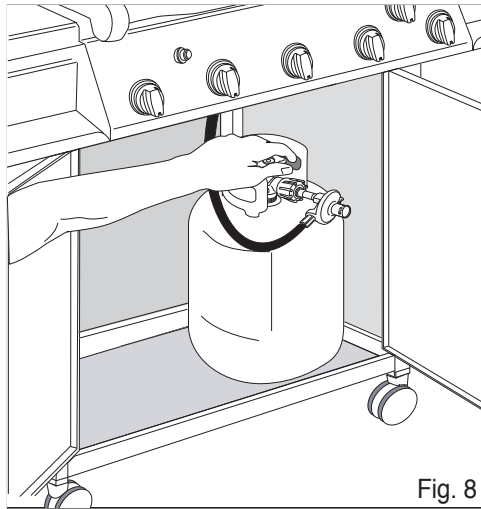

Fig. 8

WARNING: IF THE SELECTED BURNER DOES NOT LIGHT, immediately turn the burner control knob to the OFF position, to prevent gas buildup. Wait five (5) minutes for the gas to clear and then repeat the preceding starting procedure. If the burner will not light when using the Igniter, follow the match lighting instructions (see Page 8).

6. Confirm that the burner is properly lit and that the flame pattern is as desired, (see Figs. 9a, 9b & 9c, for the proper flame patterns). If the flame pattern is other than normal, consult the Troubleshooting Guide on Page 23 for corrective action.
7. Always preheat the grill before starting cooking. Light all burners and adjust them to the HIGH position for 5 to 10 minutes. Before placing any food on the Grill, clean the cooking grids with a brass wire brush.
8. Adjust the Controls to a medium setting for most cooking requirements. A light coating of cooking oil on the cooking grids, before heating the Grill, will prevent foods from sticking to the Grill.

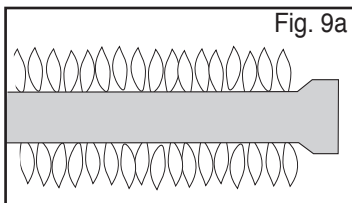

Fig. 9a

Normal: Soft blue flames

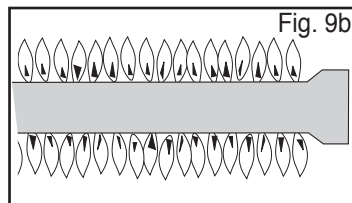

Fig. 9b

Out of Adjustment: Noisy, hard blue flames indicate too much air

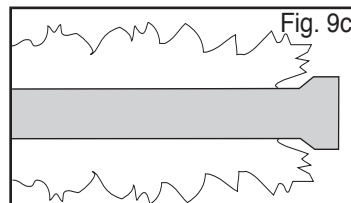

Fig. 9c

Poor Combustion: Wavy yellow flames indicate too little air

Turning the Burners Off

1. Always turn the burner control knob(s) to the OFF position when cooking has been completed.
2. Promptly turn OFF the gas supply valve at the propane cylinder or at the main natural gas supply line.
3. Close the Hood of the Grill.

FLARE-UPS

“Flare-ups” sometimes occur when food drippings fall onto the hot sear plates or burners and ignite. Some flaring is normal and desirable, as it helps impart the unique flavors associated with grilled foods. Controlling the intensity of the flare-ups is also desirable, however, in order to avoid burned or unevenly cooked foods and to prevent the possibility of an accidental fire.

- **WARNING:** Always monitor the Grill carefully while cooking and turn the flame level down (LO), or OFF, if flare-ups intensify.

MATCH LIGHTING THE MAIN BURNERS:

1. Always open the Hood completely and inspect the Grill and burners to confirm that all components are properly positioned, before lighting the main burners.

WARNING: Never stand with your head directly over the Grill when preparing to light the main burners, to prevent possible bodily injury.

2. Always confirm that all of the burner control knobs are in the OFF position before opening the gas supply.
3. Always turn on the propane gas supply valve at the tank (1 to 2 turns) or turn on the main natural gas supply valve.
4. Insert a lit match or a butane lighter into the match lighting hole located on the left hand side of the base, (see Fig. 10).
5. Turn the left Burner Control Knob to the HIGH position by pushing down on the knob and turning it counterclockwise.

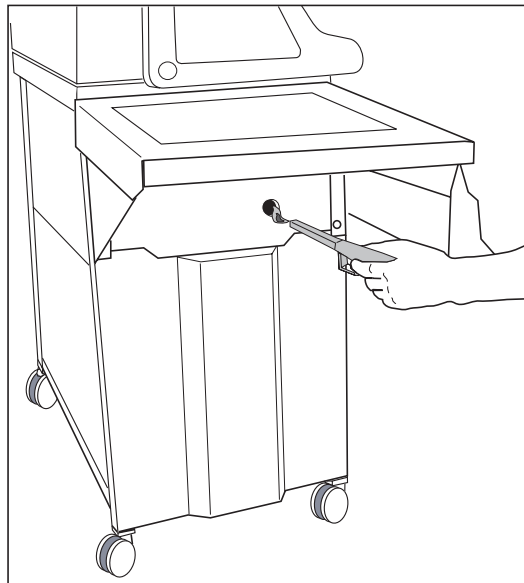

Fig. 10

Lighting the Rotisserie Burner (if applicable)

The Rotisserie burner provides the steady, even heat required to cook poultry and roasts to self-basted perfection. Please read Assembly Procedures for instructions as well.

TO START THE ROTISSERIE BURNER:

1. Always open the Hood completely before attempting to light the Grill.
 - **WARNING:** Never stand with your head directly over the Grill when preparing to light the Rotisserie burner, to prevent possible bodily injury.
2. Always confirm that all of the burner control knobs are in the OFF position before opening the gas supply.
3. Turn on the propane gas supply valve at the tank (1 to 2 turns) or turn on the main natural gas supply valve.
4. Turn the Rotisserie Burner Control Knob to the HIGH position, by pushing down on the knob and turning it counterclockwise.
5. Immediately push the Igniter Button. The Rotisserie burner should light within five seconds.
 - **WARNING:** IF THE ROTISSERIE BURNER DOES NOT LIGHT, immediately turn the burner control knob to the OFF position, to prevent gas buildup. Wait five (5) minutes for the gas to clear and then repeat the preceding starting procedure. If the burner will not light when using the Igniter, follow the match lighting instructions below.
6. Confirm that the burner is properly lit and that the flame pattern is as desired, (see Figs. 9a, 9b & 9c, for the proper flame patterns). If the flame pattern is other than normal, consult the Troubleshooting Guide on Page 22 for corrective action.
7. Always preheat the Grill before starting to cook on the rotisserie.

MATCH LIGHTING THE ROTISSERIE BURNER:

1. Always open the Hood completely, before attempting to light the Grill.

WARNING: Never stand with your head directly over the Grill when preparing to light the Rotisserie Burner, to prevent possible bodily injury.

2. Always confirm that all of the burner control knobs are in the OFF position before opening the gas supply.
3. Turn on the propane gas supply valve at the tank (1 to 2 turns) or turn on the main natural gas supply valve.
4. Insert a lit match or a butane lighter into the match lighting hole located below the rotisserie screen (see Fig. 11).
5. Turn the Rotisserie Control Knob to the HIGH position by pushing down on the knob and turning it counterclockwise.

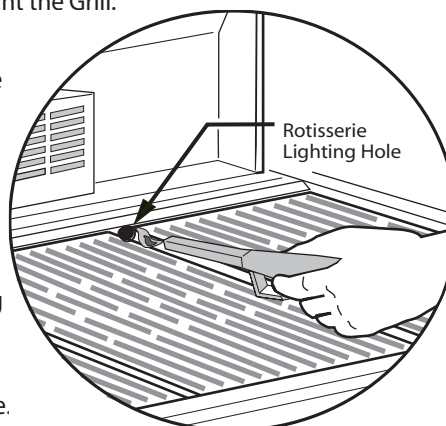

Rotisserie Setup (if applicable)

The Rotisserie burner is intended to be used for rotisserie cooking only.

WARNING: Never use the main burners while using the Rotisserie burner, as that could result in igniting the drippings, or overheating your Grill.

The Rotisserie assembly includes a counterweight for large or irregular food items ; using the counterweight will reduce the strain on the motor.

1. Remove the warming rack. Lay a flat pan directly on the cooking grates to catch drippings. Large food items may require that you remove the middle cooking grate(s), and place the pan on the sear plates.
2. Insert the ends of the Rotisserie Support into the slots of the right cooking grate, so that the edge of the support is approximately 1" from the right casting, and the top groove is in line with the rotisserie spit hole in the left casting (see Fig. 12).

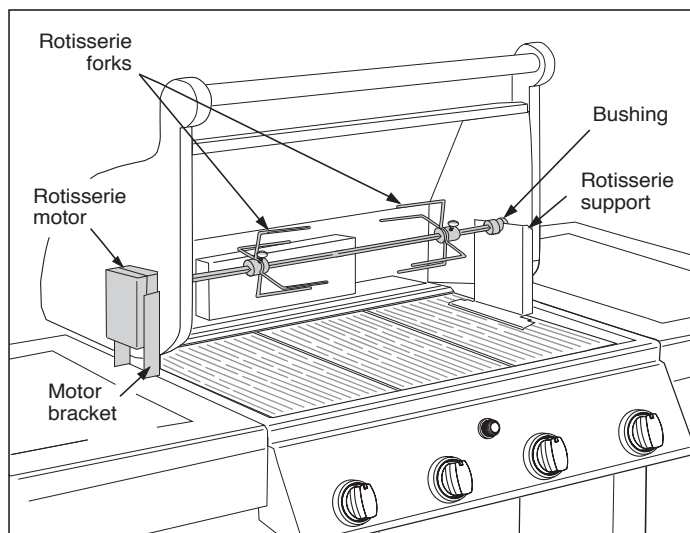

Fig. 12

3. Engage the Motor Bracket to the left side of the base as per Rotisserie instructions.
4. Engage the Rotisserie Motor in the Motor Bracket (see Fig. 12).
5. Assemble the spit and meat forks. Adjust the retainer bushing to keep the spit in place (see Fig. 12). Tighten the thumbscrews with small pliers.

NOTES: Always use the counterweight to balance the spit when cooking large or irregular food items. The Rotisserie Motor is rated to turn a maximum load of 12 lb.

WARNINGS:

- Never use the Rotisserie Motor in the rain, and never use it if it has become wet.
- Always use a grounded three-prong outlet and a three-prong extension cord to energize the Rotisserie Motor. Never alter or remove the grounding prong on the Rotisserie Power Cord, as an electric shock hazard would then result.
- Never permit an electrical supply cord or a gas supply line to contact any heated surface of this Grill.

Lighting the Side Burner (if applicable)

WARNING: Never stand with your head directly over the Grill when preparing to light the side burner, to prevent possible bodily injury.

1. Turn the side burner control knob to HIGH (see Fig. 13).
- 2a. **PIEZO IGNITION SYSTEM** - Turn the Igniter Knob clockwise until the burner ignites. The burner should light within four clicks of the igniter.
- 2b. **ELECTRONIC IGNITION SYSTEM** - Push and hold the Igniter Button until the burner ignites. The burner should light within five seconds.

NOTE: Observe the flame pattern. Soft blue flames are normal ; hard blue flames or wavy yellow flames are not. You can adjust the flame with the air shutter below the control knob (see Fig 19). If yellow flames persist, refer to the Troubleshooting Guide on Page 22.

SHUTTING THE BURNER OFF

1. Turn the control knob counterclockwise to the HIGH position, then depress it and turn it to OFF. NEVER force the knob without depressing it, as that can damage the valve.

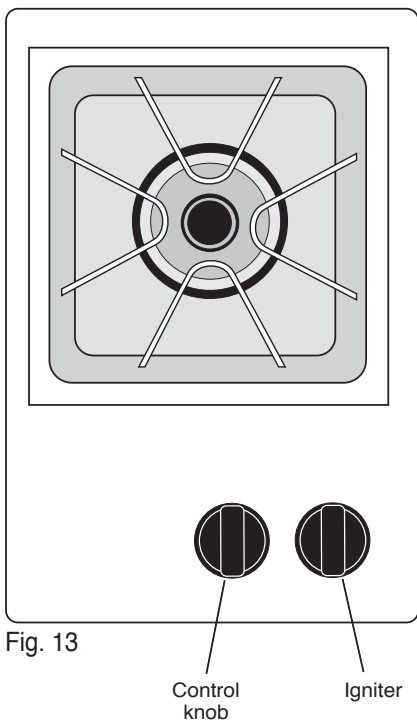

Fig. 13

(Single Burner with PIEZO IGNITION SYSTEM shown)

Methods of Cooking

With its combination of burners and accessories your gas grill can provide for virtually every conceivable style of cooking.

- The powerful **Main burners** deliver the middle and high range of temperatures desired for traditional barbecuing. This includes searing and finishing steaks, hamburgers, pork chops and the like, or grilling chicken parts, sausages, or kebabs with more moderate heat (see Fig. 14a).
- The **Rotisserie burner**, if equipped, delivers the succulent self-basted flavors of chickens, ducks and hams or pork, beef and lamb roasts that only rotisserie cooking can achieve. Also, the radiant infrared unit ensures that you will be enjoying the results much sooner (see Fig. 14b).
- The **Side burner**, if equipped, boils, sautés, stir fries or warms all with equal aplomb. Plus its high power is more than adequate for deep frying seafood, vegetables and meats or hard boiling soups, lobsters or corn on the cob (see Fig. 14c).

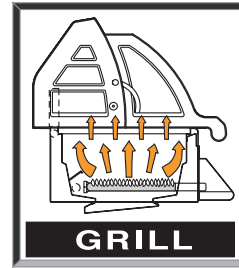

Fig. 14a

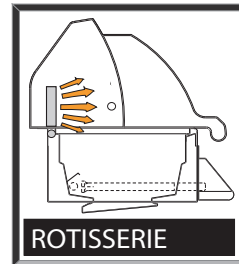

Fig. 14b

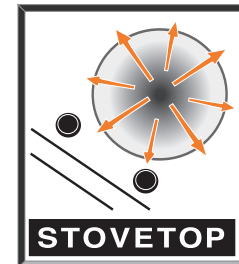

Fig. 14c

One of the keys to extending your range of grilling capabilities is a fundamental understanding of the two common methods of cooking, **Direct** and **Indirect** cooking.

In the **Direct cooking method**, food is placed directly above the heat source. This method is used in searing for example where you require high and immediate heat to quickly brown the outside layer of meats thereby sealing in their juices to enhance flavor. On the grill this is accomplished using one or both of your main burners and placing the food on the porcelain cooking grids directly over the burners. This may be done with the grill hood either open or closed.

In the **Indirect cooking method**, food is placed on the grill offset from the heat source. With the grill lid closed reflected heat surrounds the food cooking it more evenly and gently. This approximates the action of a convection oven where heat is circulated by the use of a fan to achieve a similar result. This method is perfect for cooking roasts of any kind but is also useful whenever you want to slow cook or bake a wide variety of foods. Indirect cooking on your grill is accomplished using one of the main burners and placing the food on the porcelain cooking grid above the opposite burner, or on the warming rack burner. The grill hood should always be closed when employing the indirect cooking method

PREPARING FOOD FOR THE GRILL:

WARNING: Always observe safe food-handling and safe food-preparation practices when using this Grill, to prevent food-borne illnesses :

- Always cook foods adequately. Undercooked foods can retain bacteria, especially if thawed or exposed to warm conditions prior to cooking.
- Always use a meat thermometer to confirm that foods have been fully cooked.
- Always use separate plates and utensils for the handling of raw food. Never place raw food and cooked food on the same plate, and never place cooked food on a plate that was used for handling raw food. Always carefully wash all plates and utensils used to handle raw food before using them to handle cooked food.
- Always wash all vegetables, seafood and poultry before cooking.
- Always leave uncooked foods in the refrigerator until you are ready to start cooking.
- Always marinate meat in the refrigerator. Always dispose of the excess marinade, and never reuse it.
- Always preheat your Grill for 5 to 10 minutes before cooking, and clean off all grease and food residue before using the cooking grids.

Grilling Tips:

A few helpful hints will ensure that your grilling results are perfect every time.

- Apply a light coating of cooking oil to your cooking grids before grilling, to prevent foods from sticking.
- Cook similar portion sizes together, so that they all cook evenly.
- Use tongs to turn foods on the Grill.
- Never pierce foods while they are cooking on the Grill, as this will dry them out.
- On foods such as pork chops and steak, slit the fat strip to prevent the meat from curling during cooking.
- Turn foods infrequently. Some chefs say that a good steak should never be turned more than once.
- Apply sugar-based sauces such as commercial barbecue sauces only during the latter stages of cooking, to prevent charring.
- Soak the string you use to tie up roasts and poultry on the Rotisserie spit to protect it from burning. Also, soak the wooden skewers that you intend to use for kebabs for several minutes before using them for cooking.
- Use a disposable aluminum tray filled with water, fruit juice, wine or a marinade to add extra flavor and moisture to slow-cooked foods like roasts, whole chickens, turkeys or ducks. Place the tray on top of the sear plates below the Grill surface and immediately under the foods being cooked. This will buffer the heat from below, thereby slowing the cooking process and protecting the bottom of the food from over-cooking. Check the tray periodically during cooking and keep it filled with liquid.

WARNING: Never let the tray boil dry. That could be hazardous, as grease from fatty foods that have collected in the tray could ignite and possibly cause bodily injury or property damage.

NOTE: Always trim excess fat from your foods to reduce the occurrence of flare-ups during cooking.

Cooking Time Chart

Type of Food	Weight/ Thickness	Cooking Temperature	Cooking Time
Beef			
Burgers	1 inch	400–450° F.	Rare: 4–7 min. Medium: 7–10 min. Well Done: 10–12 min.
Roasts Blade, Sirloin Tip		350°	Rare: 18–20 min./lb. Medium: 20–25 min./lb. Well Done: 25–30 min./lb.
Steaks Porterhouse, Rib, Ribeye, Sirloin, T-Bone	1 inch	Maximum (To sear) 400–450° F. (To finish)	Rare: 4–7 min. Medium: 7–10 min. Well Done: 10–12 min.
Filet Mignon	2 inches	Maximum (To sear) 400–450° F. (To finish)	Rare: 15–17 min. Medium: 17–19 min. Well Done: 19–22 min.
Poultry			
Chicken, Parts		325–350° F.	30–45 min.
Chicken, Whole	3–4 lb.	325–350° F.	20 min./lb.
Chicken Breasts, Boneless	1–2 lb.	325–350° F.	12–15 min.
Cornish Hens	1–1½ lb.	325–350° F.	45–60 min.
Duck	4–5 lb.	325–350° F.	18–20 min./lb.
Turkey	13–25 lb.	325–350° F.	20 min./lb.
Fish & Seafood			
Fish			
Fillets	1–1½ inch	400–450° F.	10–15 min.
Steaks	1–2 lb.	325–350° F.	20–30 min.
Whole Fish	2–4 lb.	325–350° F.	30–50 min.
Seafood			
Lobster	1½–2 lb.	400–450° F.	15 min.
Shrimp	Large	325–350° F.	5–6 min.

Cooking Time Chart

Type of Food	Weight/ Thickness	Cooking Temperature	Cooking Time
Pork			
Chops	1 inch	400–450° F.	25–30 min.
Ham			
Steak	1 inch	400–450° F.	12–15 min.
Whole ham	12–14 lb. Bone in	325–350° F.	Medium: 20–25 min./lb. Well Done: 25–30 min./lb.
	4–5 lb. Boneless	325–350° F.	50–60 min.
Ribs			
Back, Side	5–6 lb.	325–350° F.	Medium: 25–27 min./lb. Well Done: 27–30 min./lb.
Roasts			
Butt, Loin, Shoul- der	3–5 lb.	325–350° F.	1–1½ hrs. Medium: 30–35 min./lb. Well Done: 35–40 min./lb.
Tenderloin		375–400° F.	
Sausage	—	325–350° F.	12–20 min.
Lamb			
Chops			
Loin, Rib, Shoul- der	1 inch	400–450° F.	Rare: 7–9 min Medium: 10–13 min. Well Done: 14–17 min.
Roast			
Crown Roast	2–4 lb.	325–350° F.	40–45 min./lb.
Leg	5–9 lb.	325–350° F.	30–35 min./lb.

Cooking Time Chart

Type of Food	Cooking Temperature	Cooking Time	Comments
Vegetables			
Asparagus	325–350° F.	6–8 min.	Cut off ends of stems. Lay across the grills.
Beans	325–350° F.	30–35 min.	Wrap in foil with butter or margarine. Turn over once.
Carrots	325–350° F.	20–30 min.	Cook directly on the grill.
Corn on the Cob	325–350° F.	25–35 min.	Soak in cold water for 15 minutes. Cook with husk on.
Eggplant	325–350° F.	6–8 min./side	Cut into slices and coat with oil.
Mushrooms	325–350° F.	6–8 min.	Cook directly on the grill.
Onions	325–350° F.	40–45 min.	Wrap in foil. Turn over once during cooking.
Peppers	400–450° F.	15–20 min.	Remove charred skin before eating.
Potatoes	325–350° F.	50–60 min.	Wrap in foil. Turn over once.
Roasted Garlic	325–350° F.	30–40 min.	Cut off top of bud and lightly coat with Olive oil. Wrap in foil.
Tomatoes	325–350° F.	5–7 min.	Cut in half and coat in Olive oil.
Zucchini	325–350° F.	6–8 min./side	Cut into slices and coat with oil.

Care & Cleaning

WARNING: Always observe the following safety precautions, to prevent bodily injury and to assure that your Grill will operate properly :

CAUTION: Always allow sufficient time for the Grill to cool fully before handling or cleaning any of its parts.

BURNERS:

NOTE: All of the burners should be inspected frequently and cleaned as often as is necessary.

• Main Burner

WARNING: Always inspect the air shutter screen periodically to confirm that it is clear of food residue, spider webs or other insect debris. A clogged venturi tube can cause a fire to occur beneath the Grill, due to a flashback of gas (see Fig. 15).

NOTE: Remove the cooking Grills and the sear plates to inspect the burner at least once per year, or more frequently if required.

- Loosen the burner attachment screws (from inside) to allow the burners to be pulled away from the valves far enough for a venturi brush or suitable cleaning device to be inserted into the burner venturi to clean away debris (see Fig. 15). Be careful not to damage the electrode ceramics.
- Reinstall the burners properly over the valves (see Fig. 21). Use a wire brush or toothpick to clean the ports all around the sides of the burner (see Fig. 17). It is normal for some surface rust to appear on the burner. Severe rusting can enlarge the gas ports, however, which could cause changes in the Grill's performance.

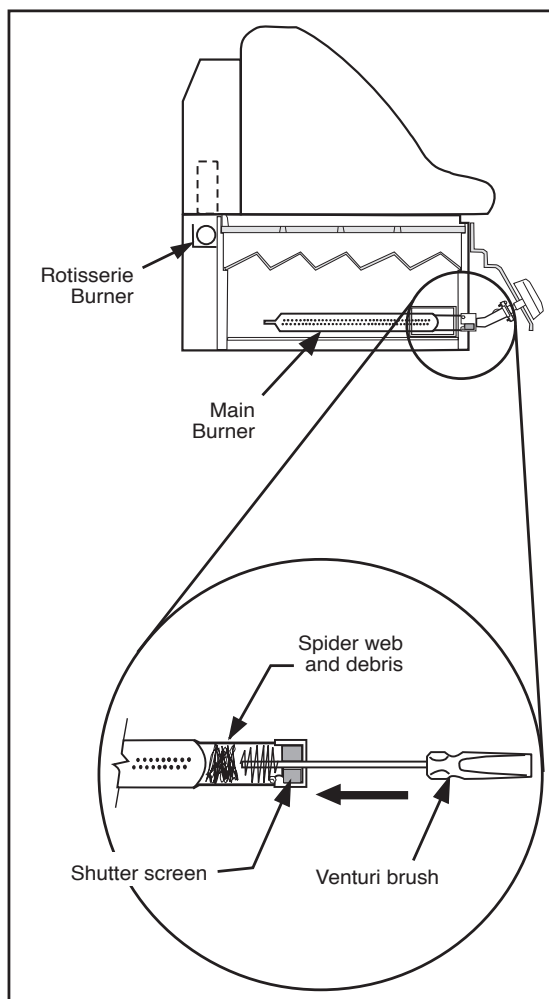

Fig. 15

- **Rotisserie Burner (if applicable)**

Inspect the Rotisserie burner monthly, if it is used frequently. Remove the rear panel to access the burner. Confirm that the burner ports and air shutter screen are clear of food residue, cobwebs or other insect debris (see Fig. 16).

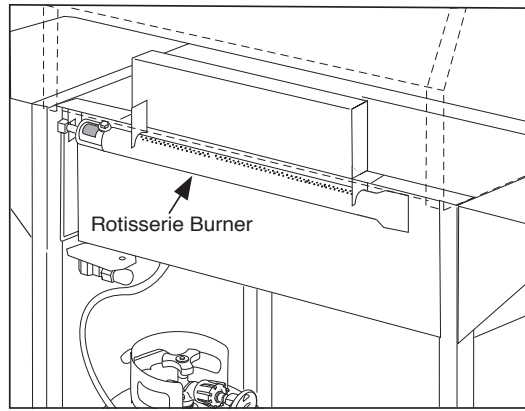

Fig. 16

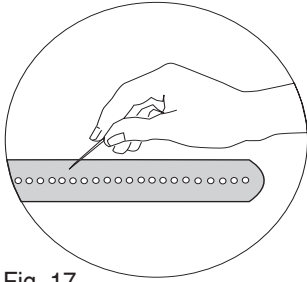

Fig. 17

WARNING: A clogged venturi tube can cause a fire to occur beneath the Grill, due to a flashback of gas.

Use a wire brush to clean all ports on the sides of the burner (see Fig. 17).

- **Side Burner (if applicable)**

Inspect the air shutter screen periodically (see Fig. 18) and confirm that it is clear of food residue, cobwebs or other insect debris. The Side Burner ignition electrode delivers a spark to ignite the gas at the burner. Always keep it clear of any buildup of foreign material, as that can act as an insulator and prevent the

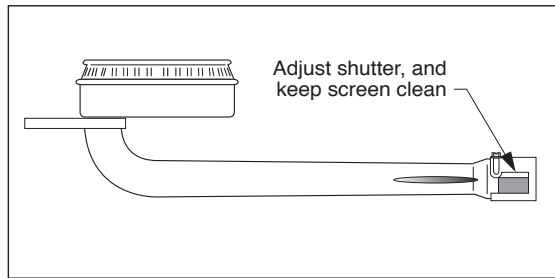

Fig. 18

- **Cooking Grids**

The cooking grids have been porcelain enameled for durability and ease of cleaning. These Grills may be cleaned with any nonabrasive cleaning agent formulated for kitchen use, or a brass wire brush.

NOTE: Always handle the grids with care, as porcelain enamel is susceptible to chipping.

DRIP TRAY

The drip tray and grease cup, located under the burner pan in the bottom of the Grill body are provided to catch excess cooking fats and juices.

The drip tray is accessible from the rear of the Grill. It is necessary to lift up the pan slightly while pulling it out (see Fig. 19).

Check it for accumulations in the grease cup after each use of the Grill, and clean it as necessary.

Use lightly abrasive or nonabrasive products only for cleaning the drip tray.

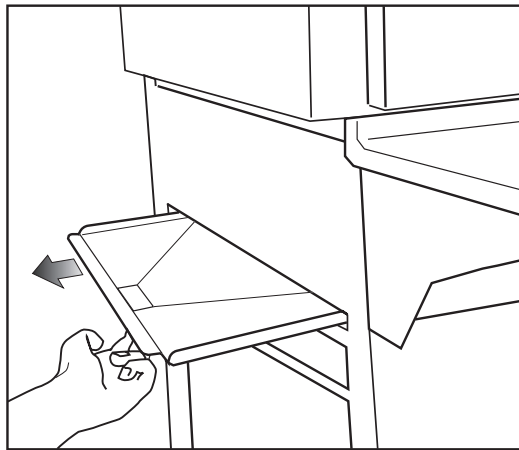

Fig. 19

STAINLESS STEEL PANELS

Stainless steel is very durable and should last indefinitely with a minimum of care. Due to the nature of its brushed surface, minor scratches may appear with normal use and handling. These may be removed with the use of a fine to medium grade Scotch-Brite* (or similar) polishing pad. Apply gentle, even pressure while rubbing with the grain of the steel. Do not rub against the grain, as damage to the finish can result. Never use steel wool on the stainless steel panels.

Periodic cleaning with a nonabrasive cleaning compound, specifically formulated for stainless steel, will remove any dirt, grease, cooking residue or discoloration that may develop.

CAUTION: Never use abrasive cleaning agents, scouring pads, or other abrasive materials to clean the stainless steel panels, to avoid scratching the surfaces.

PORCELAIN ENAMEL CASTINGS

Periodic cleaning with a dry or slightly damp cloth or soft brush will keep porcelain enamel surfaces looking new. Use a kitchen appliance cleaner or a polish expressly formulated for use on porcelain enamel to clean the porcelain enamel castings.

CAUTION: Never use abrasive cleaning agents or abrasive materials to clean the porcelain enamel castings, as they will permanently scratch the porcelain enamel surfaces. to avoid scratching the surfaces.

Maintenance

BURNER ADJUSTMENT

NOTE: It may be necessary to adjust the burners periodically, to compensate for variables in gas characteristics. If you notice that the burner flame pattern is irregular (see Figs. 9a, 9b & 9c), it may be necessary to adjust the air shutter opening at the front of the venturi tubes.

- The shutters are accessible under the control panel at the front of the Grill (see Fig. 20).
- Use a screwdriver to loosen the locking screws. Open the shutter just enough to achieve the desired soft, blue flames. Make adjustments in small increments and allow the burner to come up to operating temperature (10 min.) before making further adjustments.

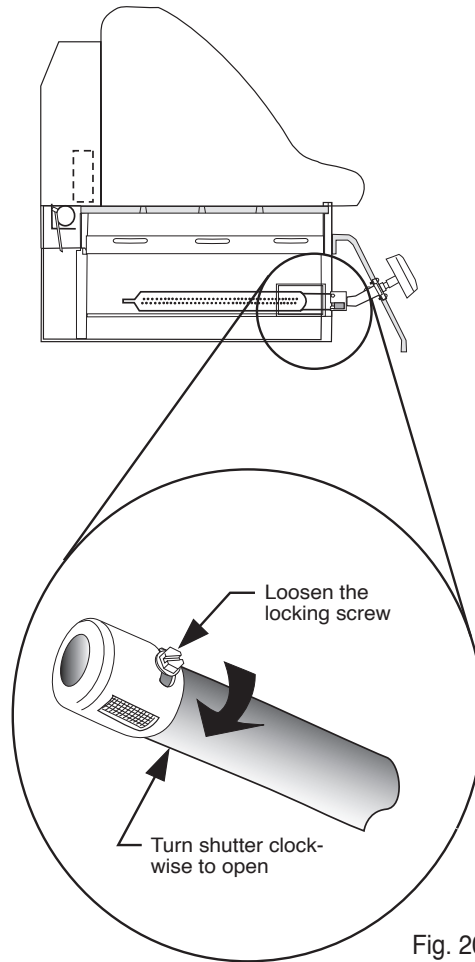

Fig. 20

If burners are removed for cleaning or adjustment, always confirm that they have been reinstalled correctly over the valve outlets (see Fig. 21). The valves should extend into the burner venturis 1/4" minimum.

NOTE: Similar adjustment can be made to Rotisserie and/or Side Burners, if so equipped.

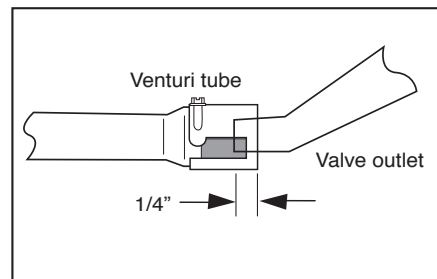

Fig. 21

PROBLEM	POTENTIAL CAUSE	ACTION REQUIRED
Burner will not light	<p>Gas supply turned off Out of propane</p> <p>Blockage in the gas system</p> <p>Misalignment of the gas valve to the venturi tubes of the burner.</p> <p>Improper attachment of the propane hose and regulator</p>	<p>Turn on fuel supply and retry.</p> <p>Confirm the flow of gas by smell or by listening for the hiss of gas being emitted. Allow gas to clear before attempting to relight.</p> <p>Weigh your propane cylinder. A standard 20 lb. cylinder will weigh about 18 lb. when it is empty and 38 lb. when it is 80 % full.</p> <p>WARNING: Never take a propane cylinder indoors for any purpose.</p> <p>Confirm that the venturi tubes are not blocked by insects or other debris. Use a special venturi brush to clean (Fig. 16).</p> <p>Use a pin or needle to carefully probe the orifice in the gas valve. Never enlarge the orifice (Fig. 18).</p> <p>Look under the front control panel and reinsert the gas injector into the venturi tube, if required (Fig. 22).</p> <p>Tighten the regulator’s plastic collar onto the cylinder valve. Hand-tighten only (Fig. 4).</p>
Unit won’t heat up (LP)	Control knob left open at startup, or turning gas on too quickly	<p>For safety, the regulator coupling on your barbecue is equipped with a flow control mechanism. This device limits gas flow in the event of a sudden change in the demand for gas. This may be engaged inadvertently, if a burner control knob should be left ON when you open the propane cylinder valve. Rapidly opening the valve can also engage flow control. To resolve the problem, close your cylinder valve. Confirm that all burner control knobs are in the OFF position. Open the cylinder valve slowly (about 1 to 2 turns) and wait 5 seconds. Finally, turn a single burner ON and try relighting it.</p>
Unit won’t stay lit	Wind Running out of fuel	<p>Always shelter your Grill from strong winds.</p> <p>Confirm the flow of gas by smell, or by listening for the hiss of gas being emitted.</p> <p>Weigh your propane cylinder. A standard 20 lb. cylinder will with about 18 lb. when it is empty ad 38 lb. when it is 80% full.</p> <p>WARNING: Never take a propane cylinder indoors for any purpose.</p>

PROBLEM	POTENTIAL CAUSE	ACTION REQUIRED
Uneven burn pattern or Flashback fire	Blockage in the burner or gas system Corroded burner	Confirm that the venturi tubes are not blocked by insects or other debris. Use a special venturi brush to clean (Fig. 15). Use a pin or needle to probe the orifice in the gas valve. Never enlarge the orifice (Fig. 17). Use a small nail or toothpick to clean the burner ports (Fig. 17). Corrosion of a gas burner can cause the solid material between the gas ports to deteriorate, resulting in uneven burning. See your retailer for the appropriate replacement burner.
Excessive yellow flame	Improper air shutter opening	Your Grill should burn with a predominantly blue flame. If the flame is mostly yellow, check the venturi tubes for obstruction and clean as shown on Page 19. If yellow flames still persist, adjust the opening on the air shutter of the venturi tube located under the front console of the Grill (Fig. 20).
Flare-up	Excessively fatty foods Grease buildup	Trim all excess fat from meat before cooking. Confirm that the sear plate is clean and properly installed. Remove excess grease from the burn chamber.
Igniter does not spark	Electrode fouled Electrode improperly gapped Electrode cracked Lead wire is disconnected Lead wire is cracked Battery dead or installed wrong	Wipe the electrode with a soft, clean cloth. The electrode should be located 1/8" to 3/16" from the burner, and positioned to spark to the edge of a gas port. If the gap is incorrect, or the unit is not properly sparking, gently bend the electrode tip into position. Use caution so that the ceramic insulator does not crack. If the ceramic insulator on the electrode is cracked, it may short out. Replace the electrode. Confirm that the lead from the Ignitor module to the electrode is well seated on the termination of the module. A crack in the lead wire may result in shorting. Replace the wire. The battery in the Igniter Button may be dead or installed incorrectly. Correct position is positive end down.

- **Lifetime Warranty**

- On all exterior Stainless Steel Components, such as the cart paneling & doors, shelving, condiment bins and handles, if so equipped.
- On all castings (1 year on paint).

- **10 Year Warranty**

- On all porcelain on steel surfaces such as the hood and burn chamber.
- On all burners except side burner.

- **5 Year Warranty**

- On all remaining parts.

- **1 Year (Accessories)**

- Rotisserie.

- The warranty is nontransferable.
- It does not cover failures due to misuse or improper installation or maintenance.
- The warranty is for replacement or repair of defective parts only. CFM Home Products will not be responsible for incidental or consequential damages or any labor costs.
- This limited warranty does not cover damage due to chipping and scratching of porcelain or painted surfaces nor does it cover corrosion or discoloring due to misuse, lack of maintenance, hostile environments, accident, alterations, abuse or neglect.
- This limited warranty does not cover any scratches, dents, corrosion or discoloring by heat, abrasive and chemical cleaners nor chipping on porcelain enamel parts, nor any components used in the installation of the gas grill.



CFM

CFM SPECIALTY HOME PRODUCTS

a division of CFM Corporation

410 Admiral Blvd. * Mississauga, Ontario * Canada L5T 2N6

phone: 1-800-227-8683

fax: 905-565-4690

www.myownbbq.com * www.vermontcastings.com