

2000C

Duct Mount Humidifier

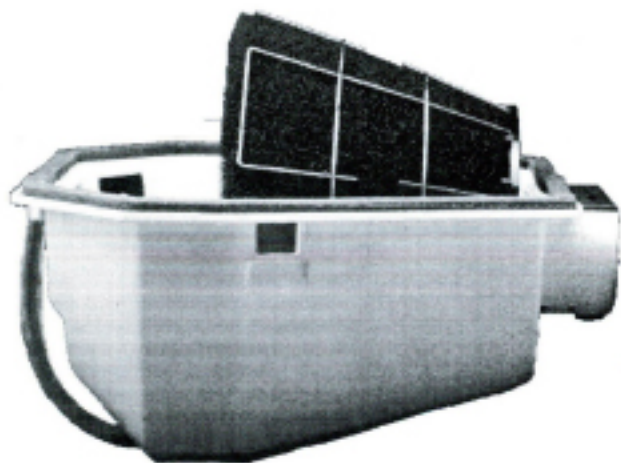

Manual for:
Installation - Operation - Maintenance

Caution: Read installation and rules carefully for safe operation.
Exercise the usual precautions when working with electricity

TRION[®]

Table of Contents	Page
Introduction	1
Specifications	4
Operation of Humidifier	5
Maintenance	6
Installation	
Physical Installation	8
Electrical Installation	11
Unit Diagram and Parts List	13

Dear Owner:

Congratulations on your choice of a Trion humidifier. Your family can now look forward to breathing more comfortable air, winter after winter. We know, because we have been engaged in the design and production of humidification equipment for home and industry for over 50 years. We are committed to providing advanced products that improve the quality of the air you breathe.

The following information will familiarize you with the operation of your new humidifier and provide helpful tips on how to obtain maximum performance from your unit.

INTRODUCTION

All humidifiers, air conditioners, refrigerators and dehumidifiers require periodic cleaning and maintenance to insure efficient and safe operation.

The benefits of a properly humidified environment (35-50%) are enjoyed by everyone living in such an comfortable environment. These benefits include both personal comfort and the preservation of furniture, draperies, carpets, wooden floors and cabinets, paintings, pianos, etc. - all hygroscopic materials. A hygroscopic material is one that has the ability to give up or absorb moisture. Your home will be more comfortable at a lower temperature (i.e.: 68° F) at 30-40% Relative Humidity (RH) than at 71° to 72° F without controlled humidity. Since every degree of temperature setback represents about 3% of your heating costs, this can represent a possible 9-12% annual saving.

During the heating season, cold air is brought into the house and heated. When heated, this air dries out and greatly increases its capacity to hold more moisture. By using a humidifier, we provide a source of water to satisfy this increased moisture holding capability, rather than having it drawn from our body surface and the surrounding hygroscopic furnishings in the home.

With the energy crisis of the mid-70's, home builders and owners have become more conscious of energy conservation. To conserve energy, homes have become tighter in construction to provide less infiltration of cold outside air and less exhaust of heated inside air. This has been accomplished by using more insulation, tighter storm windows, weather stripping and being more personally conscious of tightly closing doors and windows in general.

This tighter environment in which we now live is also a more stagnant environment and has brought about an increasing concern about "Indoor Air Quality." The air in the home is not being allowed to change as frequently.

As stated, a properly maintained and efficiently operating humidifier is a source of improved Indoor Air Quality and personal comfort. The necessity to clean your humidifier is substantially the result of impurities coming in through your water supply which feeds the humidifier. Other household dust, containing biological and microbial contaminants, finds its way into the air handling system and ultimately, the humidifier.

The humidifier is not the source of these impurities.

To enjoy the benefits of a properly humidified environment, periodic cleaning is necessary to control both water and household impurities. Film or scum, which can contain bacteria or fungi, may appear on the water surface, the sides, or bottom of your humidifier. A crusty deposit or scale may also appear and is composed of minerals that have settled out of the water. To improve the efficiency of your humidifier, and to reduce the possibility of a health hazard, it is recommended that you take the following precautions:

- Follow the manufacturer's recommended cleaning and maintenance instructions
- The amount of minerals and other impurities in a water source can vary greatly and hence, the frequency of cleaning also varies.
- During the heating season, check for film or scale build-up on a monthly basis and establish a proper cleaning schedule.
- Do not allow film or scale to build up on the unit, evaporator pad, or any moving part and reduce the efficiency of the humidifier.
- An algaecide, such as a humidifier cleaning tablet or bacteriostatic liquid/powder, can be used to combat algae build-up, should it become evident.
- At the end of the winter humidification season, drain and thoroughly clean your humidifier as part of the summer shut down.

Like your heating system and air conditioning unit, periodic maintenance and cleaning are required to ensure the safe and efficient operation of your humidifier. This cleaning necessity is also likened to weekly house cleanings and periodic maintenance of your automobile for its safe and efficient operation.

SPECIFICATIONS

	2000C
Type of Unit	Under-duct Rotating Drum
Duct Mounting	Supply
GPD @ 140° F	25.0
GPD @ 120° F	20.0
GPD @ 100° F	14.4
Voltages	24V
Unit W x D x H	16 ¹ / ₂ " x 15 ³ / ₈ " x 7 ⁵ / ₈ "
Duct Opening W x H	See template
Shipping Weight	13 lbs.
Standard Equipment	Duct mount humidistat Self-piercing saddle valve Adjustable baffle
Features	External water level indicator Two observation windows Externally held evaporative media Integral bleed-off assembly Easily adapted to 12" duct Externally adjustable float assembly All brass valve assembly Easily maintained 2 Year Warranty

OPERATION OF HUMIDIFIER

This Challenger 2000 humidifier operates on the silent principle of evaporation. When the unit is operating, you can see the evaporator pad rotating through the observation window (a flashlight may be needed). Evaporation takes place as air passes through the pad held by the specially engineered rotating cage. Operation is completely automatic, controlled by the adjustable humidistat. The Challenger 2000 will only humidify when the furnace blower operates. The evaporator pad could rotate when the furnace blower is off. This situation will help wash the evaporator pad and reduce the frequency of maintenance. The Challenger 2000 is designed for use with hard or soft water.

Set the humidistat in the recommended range of 30-50% relative humidity for automatic humidity control during the heating season (a lower setting may be used to control condensation on single pane windows). During the first heating season, check the mineral build-up every month to establish the proper cleaning schedule. Clean the unit at the end of each heating season or whenever mineral deposits appear to clog the openings in the evaporator pad.

You can easily check your Challenger 2000 to be sure it is in working condition. Simply turn the humidistat to a higher setting and look through the observation window. If the unit is working properly, the evaporator pad will be rotating. Be sure to set the humidistat back to the desired level.

For shutting the humidifier down for the summer months, start with cleaning any mineral accumulation from the unit. Leave the water turned off and the unit dry. Turn the humidistat to the OFF position and remove the entire evaporator pad and cage assembly if central air conditioning equipment is to be used.

At the beginning of the heating season, return the entire evaporator pad and cage assembly to its original location. We recommend that you replace the evaporator pad each heating season. Turn on the water, check the water level within the humidifier and return the humidistat to the desired level.

MAINTENANCE INSTRUCTIONS

Periodic cleaning is required for the efficient and safe operation of this humidifier. Inspect the Challenger 2000 approximately once a month for mineral and algae growth. Algae may develop inside your humidifier if certain conditions exist in the water supplying the unit. Algae is a slimy substance which can be green, brown or white. It is advisable to add an algaecide to the water on a weekly basis. This algaecide can be 10 drops of Clorox bleach or humidifier tablets purchased through your local dealer. Periodic cleaning and removal of accumulated mineral deposits and algae growth will be the only maintenance this unit requires. The frequency of this maintenance will depend on the mineral content, or hardness, of the water being supplied to the humidifier.

To inspect the unit:

1. Set the humidistat to the OFF position and disconnect the humidifier from the 24-volt power source.
2. Turn off the water from the saddle valve and disconnect water line from the humidifier.
3. Drain any excess water from the reservoir pan by pulling down, releasing the drain tube, and allowing the water to run into a bucket or drain. When empty, replace the tube onto the hook.
4. Hold the unit firmly and remove the thumb knobs from the side flange. Remove the humidifier from the mounting screws and mounting clip.

NOTE:

The frequency of cleaning can be greatly reduced through the utilization of the bleed-off assembly.

To clean the unit:

1. If the evaporator pad appears clogged with mineral deposits, remove the cage and pad assembly from the humidifier.
2. Carefully remove the cage end support from the motor drive shaft.



Figure 5 – Pad Removal

3. To prevent damage, make sure that the evaporator pad is wet while handling.
4. Coil the evaporator pad to free it from the wire cage through the wide end of the cone assembly.
5. Clean and rinse the pan. Suggested cleaners include a 50/50 solution of white vinegar/water and liquid humidifier cleaner.
6. Install the new evaporator pad by reversing the previous procedure. Insure that the seam does not extend beyond the outside of the cage assembly.
7. Position the cage end support onto the shaft - "U" forms (or covered ends) face away from the evaporator pad. Place the support ends inside the cage wire corners ("U" ends compress the evaporator pad to the cage).
8. Replace the cage and pad assembly.
9. Replace the humidifier to its original installed position under the duct.
10. Connect the water line to the valve. Turn on the water at the saddle valve. Check the water level and adjust if necessary (see Step #23 of Physical Installation instructions for further information).
11. Use wire nuts to reconnect the unit to the 24-volt power source. Hold the bare wires together (one humidifier wire to one power wire) and rotate the wire nut clockwise until tightly secured.
12. Turn the humidistat to the desired humidity level.

INSTALLATION INSTRUCTIONS

PHYSICAL INSTALLATION

Remember to select a location that is readily accessible for periodic inspection and cleaning of your humidifier. Allow a minimum of 12" clearance in front of the humidifier and 12" below the water pan to allow for maintenance and repair.

CAUTION:

Only a trained service person should install this humidifier. Do not connect the unit to power source until installation is complete. A thorough checkout of the unit installation should be completed before operation. Failure to follow these directions may void the manufacture's original warranty.

Prior to installing this product...

1. Read the instructions carefully to ensure safe operation. Failure to follow them could damage the product or cause a hazardous condition.
2. Check the ratings given on the product to make sure it is suitable for your application.
3. Place the edge of the template marked INTAKE END toward the furnace (2" from the duct joint for added rigidity).
4. Center the mounting template on the underside of the supply duct and trace around the outside edge of the template
5. Cut a hole in the duct using the marked lines. On narrow ducts, cut out as much of an opening as physically possible. A clean cut at the 90° edges is essential.
6. Remove all parts from the carton. Separate the evaporator pad assembly (cone shaped media) and cardboard carton filler from the pan.
7. Slide the mounting clip onto the edge opening (Fig.1)

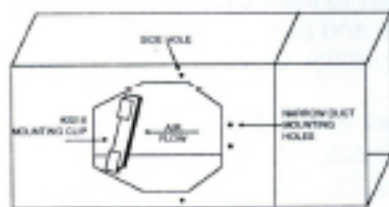

Fig. 1

8. Insert the rim of the pan (at the motor end of the unit) into the mounting clip. Swing the pan up, flush to the duct, and mark location of the (2) side holes on the duct. On narrow ducts, mark location of the (2) front holes on the duct. Take down the unit.

9. Drill (2) $\frac{1}{4}$ " diameter holes as marked above.
10. Assemble the deflector mount to the deflector with the (3) sheet metal screws provided (Fig. 2).
 Note: Deflector mount is not to be used on narrow duct installations.

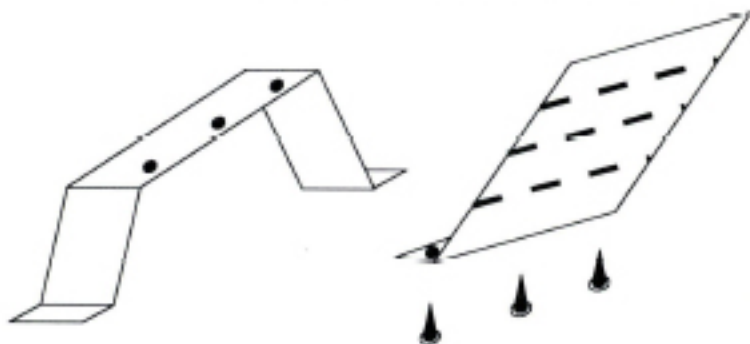

Fig. 2

11. The deflector fits 12" high ducts and must be broken off at perforations for smaller ducts. On narrow ducts, invert deflector and secure it to the top of the duct with sheet metal screws.
 NOTE: Be certain that the deflector is pointed toward unit and does not interfere with the rotation of the pad assembly.
12. Push the deflector mount assembly through the hole in the duct, with the deflector facing toward the furnace (intake end).
13. Insert the deflector mount screws through the $\frac{1}{4}$ " side holes and secure with #10 hex nuts provided. On narrow ducts, use 10-24 x $\frac{3}{4}$ " screws through the front holes.
14. A bleed off assembly has been provided to reduce maintenance in hard water areas. If flushing is not desired, disconnect the bleed off assembly. Remove the cage and evaporator pad assembly and cage end support by unhooking its two ends from the cage and sliding it off the shaft. Turn the cage end support over so that the two drive fingers now face the inside of the cage and evaporator pad assembly. Slip it over the end of the shaft and reconnect the two ends to the cage.

- Slide the closed end of the evaporator pad assembly onto the motor shaft and swing the shaft into the saddle bearing at the opposite end (see Fig. 3).

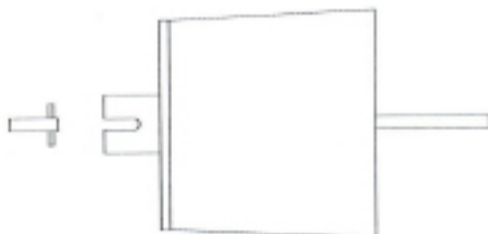

Fig. 3

- Install unit by placing the rim of the pan (at the motor end) into the mounting clip on the duct and swing the unit up. The deflector mounting screws will extend through the side flange holes (the front holes on narrow ducts). Fasten the unit in place with the thumb knobs provided.
- On narrow ducts, cut a piece of sheet metal to the shape of the pan overhang. Provide enough material for a 90° bend, 1" wide, to fasten the overhang cover to the vertical sides of the duct. Drill (2) $\frac{3}{32}$ " holes through the 1" lip and vertical duct. Fasten the cover with #10 sheet metal screws.
- Select the location of the humidistat, on the return air duct, and mount according to the instructions provided with the control. Wall mounting of the humidistat is an option.
- Connect $\frac{1}{2}$ " I.D. hose (not provided) to the overflow drain of the unit. Fasten with clamp provided and run the line to an open drain.

NOTE: If unit is installed where accidental overflow could cause water damage, the overflow hose **MUST** be installed and run to an open drain.

20. Install the saddle valve (see instructions on the package) to an available water line. Before connecting the $\frac{1}{4}$ " tubing to the float & valve assembly, open the saddle valve and allow water to flush the line free of any debris that may have accumulated during the installation process.
21. Connect the tubing to the saddle valve. Either hard or softened water may be used in the unit. However, hard water may cause clogging issues and must be periodically checked.
22. Turn on the water and check for leaks in the piping. The line on the pan is the recommended water level and this may be observed through the drain tube.
23. Adjust the water level by loosening the $\frac{3}{4}$ " brass hex nut and sliding the float & valve assembly up and down as required. Tighten the nut when finished adjusting.

ELECTRICAL INSTALLATION

This humidifier is intended to be wired directly to the integrated control panel on your furnace. The electrical tap will provide power to the humidifier whenever the circulating air blower is in operation.

1. Turn the humidistat to the highest level (past 60%) and the humidifier should begin to run. The humidifier should stop when the humidistat is turned off.
2. Set the furnace controls and humidistat for the desired conditions (30-40% RH is recommended). Operation of this unit is automatic.

Humidifier Capacity Selection Guide

Sq. Footage of Home	Tight House	Average House	Loose House
1000	0.5 GPD	5.0 GPD	10.0 GPD
1500	3.0 GPD	10.0 GPD	16.5 GPD
2000	5.0 GPD	14.0 GPD	24.0 GPD
2500	7.5 GPD	19.0 GPD	30.5 GPD
3000	10.0 GPD	23.5 GPD	37.5 GPD
4000	14.5 GPD	33.0 GPD	51.5 GPD

For reference only - calculations based on:

- Indoor temperature of 70° F and 35% Relative Humidity
- Outside temperature of 20° F and 70% Relative Humidity
- 8' Ceiling height
- Internal moisture gain of 1 lb. Per hour
- Furnace on-time of 70%

This chart uses A.R.I. standard designations:

- A Tight House is assumed to be well insulated with vapor barriers, tight storm doors and windows and a dampered fireplace. Air change rate of .50 changes per hour.
- An Average House is insulated and has a dampered fireplace, but there are no vapor barriers and storm windows and doors are assumed loose. Air change rate of 1.0 change per hour.
- A Loose House is generally one constructed before 1930, having little or no insulation, no storm doors or windows, no weather stripping or vapor barriers and often, no effective dampering of fire places. Air change rate is as high as 1.5 per hour.

UNIT DIAGRAM AND PARTS LIST

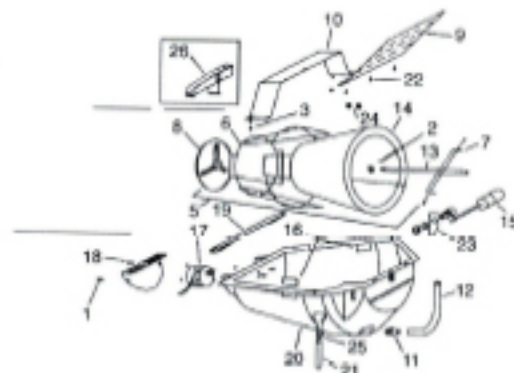

Ref. #	Description	Part #
1	#6 - 20 x 3/8" Cover Plate Screw (2)	1028
2	1/2" - 20 S.S. Nut for Drive Rod	900-185
3	#10-24 Hex Nut [for Deflector Mount] (2)	1216
4	#10 - 24 x 3/4" Screw for Narrow Duct Mount (2)	Not Shown
5	Cage & Pad Assembly	2040
6	Cage Assembly	2012
7	Cage End Support with (2) End Caps	2017A
8	Closed End	1402-01
9	Deflector	2014
10	Deflector Mount with Weld Screws	2013
11	Drain Connection	2026
12	Drain Tube 9 1/2"	2029
13	Drive Rod	2018
14	Evaporator Pad	2024
15	Float & Valve Assembly	1405A
16	Observation Window (2)	2023
17	Motor 24V (replaces 1414A)	1322
18	Motor Cover Plate	2031
19	Mounting Clip	2016
20	Pan with #2025 Seal & #2023 Bearing	2010
21	Plastic Drain Tube 6"	1094
22	Sheet Metal Screw (5)	22
23	Splash Shield	2021
24	Thumb Screw Knob (2)	2030
25	Tube Clamp for Bleed-Off	1095
26	Bleed-Off Assembly	2055

ELECTRONIC AIR CLEANER AND HUMIDIFIER LIMITED TWO-YEAR WARRANTY

This limited warranty covers Trion Residential Type Electronic Air Cleaners and Humidifiers, excluding duct work, wiring and installation.

Trion, Inc. warrants that all new Trion Residential Type Electronic Air Cleaners and Humidifiers are free from defects in material and workmanship under normal, noncommercial use and service. Trion will remedy any such defects if they appear within 24 months from the date of original installation as evidenced by receipt of the warranty registration card, subject to the terms and conditions of this Limited Two-Year Warranty stated below.

1. THIS LIMITED TWO-YEAR WARRANTY IS GRANTED BY TRION INC., McNEILL ROAD, P.O. BOX 760, SANFORD, NORTH CAROLINA 27330.
2. This warranty shall extend only to any noncommercial owner who has purchased the residential electronic air cleaner or humidifier other than for purposes of resale.
3. The completion and return of the Warranty Registration Card is a condition precedent to warranty coverage and performance.
4. All components are covered by this limited warranty except expendable items, such as charcoal filters, disposable dirt holding pads, media evaporative pads, media filter pads and nozzles.
5. If within the warranty period any Trion residential electronic air cleaner or humidifier unit or related component requires service it must be performed by a competent heating and/or air conditioning contractor (preferably the installing contractor). Trion, Inc. will not pay shipping charges, or labor charges to remove or replace such defective parts or components. If the part or component is found by inspection to contain such defective material and workmanship it will be either repaired or exchanged free of charge at Trion's option, and returned freight collect.
6. In order to obtain the benefits of this limited two-year warranty, the owner must notify the dealer or distributor in writing of any defect within 30 days of its discovery. If after reasonable time you have not received an adequate response from the dealer or distributor, notify in writing Trion, Inc., McNeill Road, P.O. Box 760, Sanford, North Carolina 27330. Console or portable models of the electronic air cleaner or humidifier may be returned intact freight prepaid, but electronic air cleaners or humidifiers which have been installed or become part of real estate cannot be returned. Trion will receive, freight prepaid, only removable parts or components of such defective electronic air cleaners or humidifiers.
7. This limited warranty does not apply to any part or component that is: damaged in transit or when handling, has been subject to misuse, neglect or accident; has not been installed, operated and serviced according to Trion's instruction; has been operated beyond the factory rated capacity; or altered in any such way that its performance is affected. There is no warranty due to neglect, alteration or ordinary wear and tear. Trion's liability is limited to replacement of defective parts or components and does not include the payment of the cost of labor charges to remove or replace such defective components or parts.
8. Trion will not be responsible for loss of use of any product; loss of time, inconvenience, or any other indirect, incidental or consequential damages with respect to person or property, whether as a result of breach of warranty, neglect or otherwise. **SOME STATES DO NOT ALLOW THE EXCLUSION OR LIMITATION OF INCIDENTAL OR CONSEQUENTIAL DAMAGES, SO THE LIMITATION OR EXCLUSION IN THE PRECEDING SENTENCE MAY NOT APPLY TO YOU.**
9. **THIS WARRANTY GIVES YOU SPECIFIC RIGHTS, AND YOU MAY ALSO HAVE OTHER RIGHTS WHICH VARY FROM STATE TO STATE.**
10. Any warranty work will be performed within a reasonable time, usually within 120 days after notice of defect and delivery to the Trion factory, subject to delays beyond Trion's control.
11. Any warranty be Trion of merchantability, fitness for use or any other warranty (express, implied or statutory), representation or guarantee other than those set forth herein, shall expire at the expiration date of this express limited warranty. **SOME STATES DO NOT ALLOW LIMITATIONS ON HOW LONG AN IMPLIED WARRANTY LASTS, SO THE LIMITATION IN THE PRECEDING SENTENCE MAY NOT APPLY TO YOU.**
12. Trion reserves the right to make changes in the design and material of its products without incurring any obligation to incorporate such changes in units completed on the effective date of such change.

TRION INC.