

Installation Instructions & Owner's Manual

AUTOFLO MODEL 40 Series Humidifier

FOR GAS OR OIL, FORCED AIR OR GRAVITY FURNACES (NOT SUITABLE FOR HEAT PUMPS)

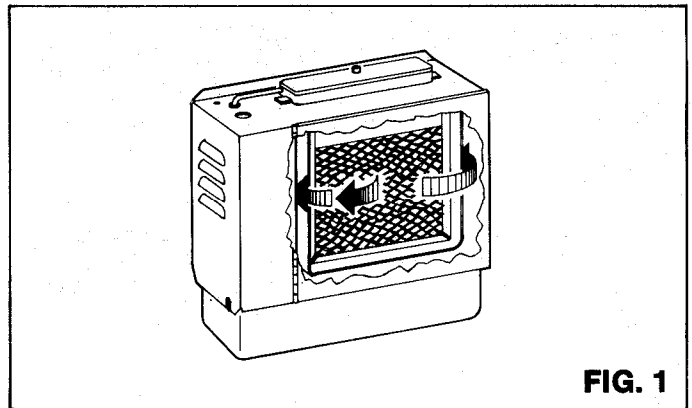
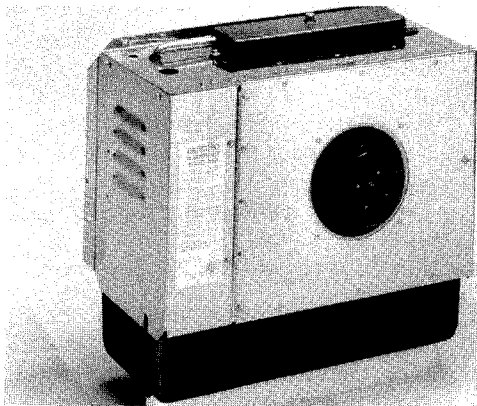

OPERATION

The Model 40 series Humidifiers utilize a forced-air evaporative principle to add moisture into the warm air duct of your central heating system. Water is fed into a distribution trough at the top of the humidifier. The trough has six outlet holes which drip water into a replaceable evaporative media pad. This moisture-laden air is returned to the warm air duct through rectangular openings outside both ends of the media pad, (Fig. 1).

Model 40 RECIRCULATING UNIT

A water pan, located on the bottom of the humidifier, serves as a reservoir. The water level in the reservoir is automatically controlled by a float valve assembly. A pump carries water to the trough at the top of the humidifier. Any water that is not evaporated as it passes

through the media pad is returned to the water pan. This water is mixed with fresh water, coming in to replace the water that was evaporated.

Model 40S SOLENOID UNIT

Water is supplied to the distribution trough through a solenoid valve. The rate of water flow is regulated by an orifice, located at the outlet of the solenoid. Any water that is not evaporated, as it passes through the media pad, is expelled into a drain as waste water. Solenoid units are recommended for areas with a high concentration of minerals in the water supply. In these areas a recirculating unit would require frequent cleaning and media pad replacement.

WHAT IS RELATIVE HUMIDITY?

Humidity level both inside and outside your home is expressed by the term "Relative Humidity." Relative humidity is the percentage (%) of water vapor within the air, compared to the total amount of water vapor the air is capable of absorbing. As an example, 50% relative humidity means that the air is holding half of the moisture it is capable of absorbing at the present temperature. At one extreme is 100% relative humidity. If this condition exists outdoors and condensation occurs, it is raining.

Warm air is capable of absorbing much more water vapor than cold air. When cold air is heated by your fur-

nace it does not necessarily lose moisture. This may cause you to ask why air with a high relative humidity outdoors feels dry indoors after it is heated. This is because the warmer air can now hold much more moisture than it could when it was cold. Consequently, the relative humidity may have dropped to an uncomfortably low level. Refer to the "Relative Humidity Chart" to determine the effects on relative humidity when air is heated to 72 degrees F.

The installation of an AutoFlo Humidifier will allow you to add moisture to heated air, thereby increasing its relative humidity.

BENEFITS OF PROPER RELATIVE HUMIDITY

Some of the benefits of maintaining proper relative humidity are listed below.

You will feel warmer at a lower temperature (thermostat setting). This is because water evaporates more slowly from the skin in humid air which gives a feeling of warmth. In drier air, water evaporates more rapidly which cools and dries the skin.

Shocks from static electricity will be reduced. This is because static charges are normally grounded through

the moisture in the air. With a low relative humidity there is insufficient moisture to ground all the static charges. In very dry air the only way these charges can be grounded is through a conductor, such as a person touching a metal object, resulting in a shock.

Shrinking and warping of woodwork and furniture will be reduced. A proper relative humidity level also reduces splitting and cracking of wallpaper and helps carpeting and draperies retain their resiliency.

PARTS LISTS

Unpack the AutoFlo Model 40 Power Humidifier and familiarize yourself with the following parts.

PARTS INCLUDED

1. Model 40 Power Humidifier
2. Evaporative Pad
3. Saddle Tapping Valve Kit
4. Mounting Flange
5. Mounting Template
6. Nine (9) #8 x 3/8 Sheet Metal Screws

ADDITIONAL RECOMMENDED PARTS

Check with your AutoFlo dealer for appropriate part numbers.

1. AutoFlo Humidistat. A line voltage (120 volt) humidistat is required for Models 40 and 40S.
2. Relay with 120 volt coil, for furnaces with multi-speed blower motors. (See Electrical Connection and Wiring Diagrams for details).
3. Drain Tubing, 5/8 inch plastic or rubber tubing or a piece of 5/8 inch garden hose.
4. Small Hose Clamp for drain tubing.
5. 1/4 inch O.D. Copper Tubing for water connection.

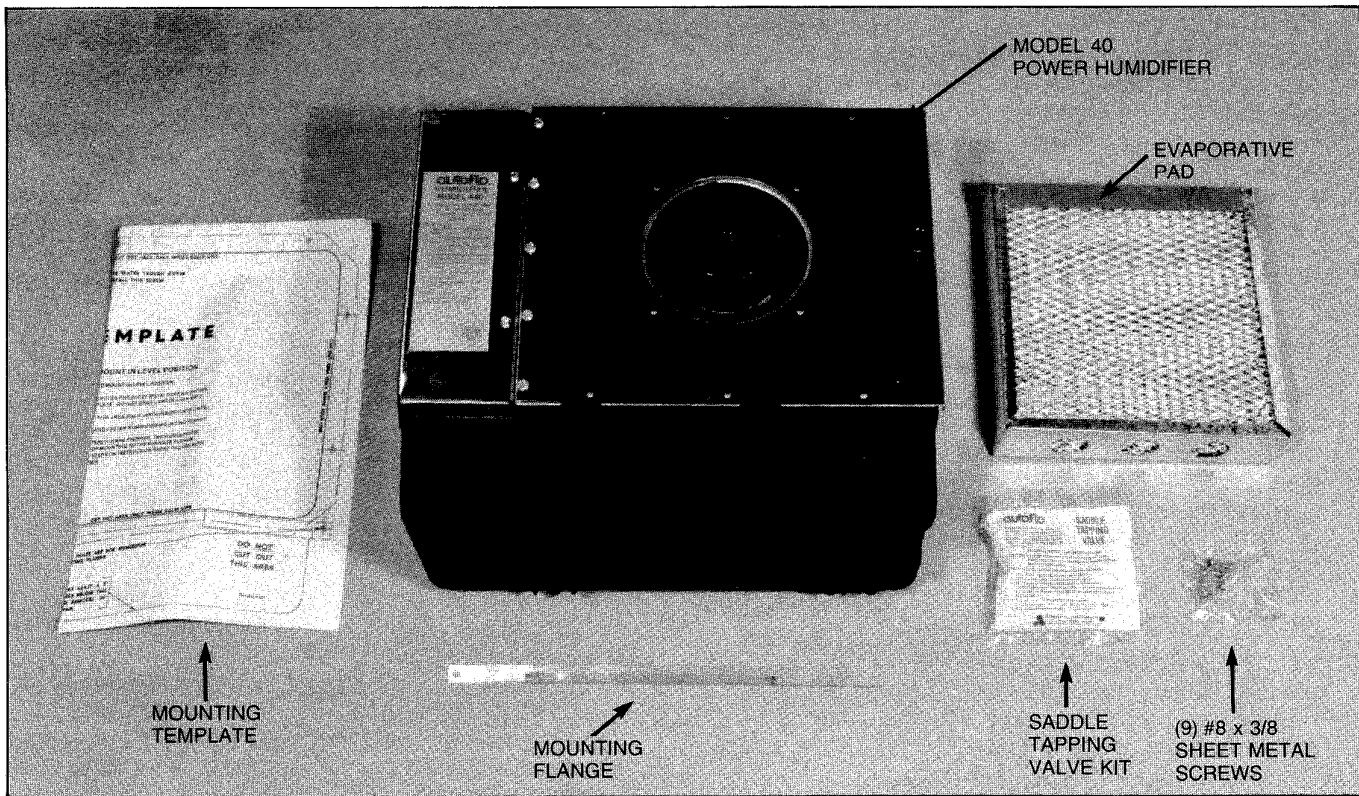

RECOMMENDED LOCATION

The AutoFlo Model 40 series Humidifiers are designed for installation on the side of a warm air part of the duct system. The preferred position is to locate the humidifier as close as practical to the heating unit (Fig. 2), DOWNSTREAM from the evaporator coil of the air conditioner system. The duct must be at least 13-1/2 inches wide and 11-1/2 inches in height. Do not install where the humidifier or water connections may be exposed to freezing temperatures or outside weather.

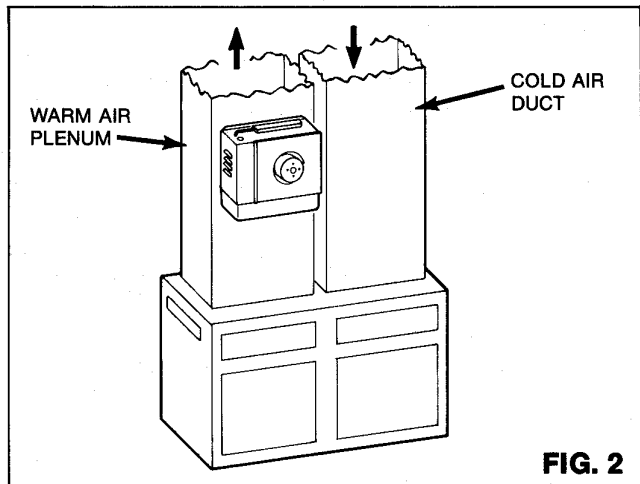

STEP BY STEP INSTALLATION

1. ATTACH TEMPLATE AND CUT OPENING

We recommend that you use leather gloves and protective eyewear while cutting and drilling sheet metal.

Tape the Mounting Template to the side of the warm air duct. Use a level or plumb line to make sure the template is LEVEL. Before proceeding, verify that adequate clearances are available for opening the humidifier's door and removing the water pan. These

are a minimum of 20 INCH CLEARANCE FROM FACE OF DUCT and 3 INCH CLEARANCE BELOW BOTTOM OF HUMIDIFIER. If necessary, relocate template.

Drill nine (9) 1/8-inch holes as indicated on the template. Drill or punch a starter hole and then use a reciprocating saw or sheet metal shears to cut the opening. Cut only on the solid line as indicated on the mounting template. Next, remove the template and tape.

2. INSTALLING HUMIDIFIER

Before installation, remove the control compartment cover from the left side of the humidifier. Remove the water distribution trough cover by loosening the thumb screw on the top of the humidifier. Open the service door and remove the packing material from above the evaporative pad. Remove the water pan by loosening the two thumb screws just inside the service door. Remove all packaging material and installation components from the water pan and float assembly.

Reinstall the water pan being careful not to deform the float assembly. Check to see that the lip at the rear of the water pan is engaged in the two rear support clips. Close and fasten the service door.

Use two (2) #8 x 3/8 sheet metal screws to attach the Mounting Flange to the duct. Place the bottom lip of the humidifier into the Mounting Flange and use seven (7) #8 x 3/8 sheet metal screws to fasten the humidifier to the duct. Make certain the unit is *level* both side to side and front to rear. Next replace the water distribution trough cover.

3. DRAIN CONNECTION

Model 40S requires a drain line connection. We also recommend that a drain line be used as an emergency overflow on the Model 40.

Use a hose clamp to connect 5/8 inch I.D. plastic or rubber tubing to the drain or overflow spout. The spout is located on the bottom right side of the water pan. Do not use rigid piping because the water pan must be removable for routine cleaning and servicing. Keep the hose as short as possible and avoid sharp bends. The drain line should be routed on a continuous downward slope and into a suitable drain. The drain inlet should be at least eighteen (18) inches below the bottom of the water pan.

4. WATER CONNECTION

Water for the humidifier must be taken from a nearby water line.

If this humidifier is installed in, above, or adjacent to a decorated living area, an emergency overflow pan (with a drain) should be installed below the humidifier.

Do not use any line connected to an air conditioner. Lines connected to air conditioners generally carry refrigerant and are not water lines.

Do not use any line which is served by a water softener. If your home has a water softener, make the water connection to a water line *upstream* from the water softener. A water softener is not a demineralizer. It merely exchanges various hard ions for soft ions in the water. These soft ions, or minerals, will build up in the humidifier, causing a need for frequent servicing. The evaporation of softened water may also produce a white powder which may be carried into the duct system and, ultimately, into your home.

Follow the instructions printed on the Saddle Tapping Valve Kit and install the valve. The valve should be mounted either on top of or on the side of a water line. If the valve is mounted on the bottom of the line, sediment in the water line will clog the valve.

Using 1/4 inch O.D. COPPER TUBING connect one end to the saddle valve. Route the tubing to the lower-left side of the humidifier. The tubing should enter the humidifier at the "U" shaped notch at the upper-left side of the water pan. Connect the tubing to either the float valve or solenoid inlet.

For Solenoid Units, support the tubing securely enough to prevent vibration when the valve operates. For Recirculating Units, support the tubing but allow enough movement for float adjustment at the humidifier.

5. ELECTRICAL CONNECTION

Basically, the humidifier should be wired in parallel with the furnace blower so that it only runs when the furnace blower is operating. We recommend that an AutoFlo 120 volt humidistat be wired in series with Models 40 and 40S.

SHUT OFF THE POWER TO THE FURNACE BEFORE PROCEEDING.

Compare the wiring diagrams in these instructions to those of your furnace and determine where connection will be made.

IF YOU HAVE ANY DOUBT ABOUT YOUR ABILITY TO PROPERLY WIRE THIS UNIT, WITHOUT DEFEATING ANY SAFETY CONTROLS OF YOUR FURNACE, A QUALIFIED ELECTRICIAN SHOULD BE CONSULTED.

Follow the instructions packaged with the AutoFlo humidistat and mount the humidistat.

Make sure all wiring conforms to local codes for both type and protection of wiring. Connect the humidifier as indicated in the wiring diagrams. Make sure the humidifier is grounded.

6. OPERATIONAL CHECK

Return the power to the furnace and turn on the main water supply and saddle valve. Set the humidistat to the highest setting. Turn the furnace on and verify that the humidifier is operating when the furnace blower is activated.

7. FLOAT ADJUSTMENT

This procedure is required for Recirculating Units only. If you have a Solenoid Unit skip this step. If the humidifier is connected to an electrical source, **TURN OFF THE POWER TO THE HUMIDIFIER** and remove the control compartment cover.

The float has been set at the factory for normal water pressure conditions. The float should completely shut off the water when the water level is 1/2 inch to one inch above the top of the pump housing (or 1-1/2 inches to 2 inches above the bottom of the water pan). Loosen the screw on the float mounting bracket. This screw is located just above the water connection. Slide the float assembly up to raise the water level or down to lower the water level. Operate the humidifier until water begins to flow through the float valve. **TURN OFF THE POWER TO THE HUMIDIFIER** and recheck the water level. Additional adjustment may be accomplished by the float bulb adjustment screw. Refer to the Maintenance section of these instructions for removing and replacing the water pan. With the water pan removed the float will swing down to pro-

vide access to the adjustment screw (Fig. 3). Turn the screw clockwise to lower the water level or counter-clockwise to raise the level. Adjustment of the crutch tip screw is not recommended. Replace the water pan and recheck the water level.

Replace the control compartment cover.

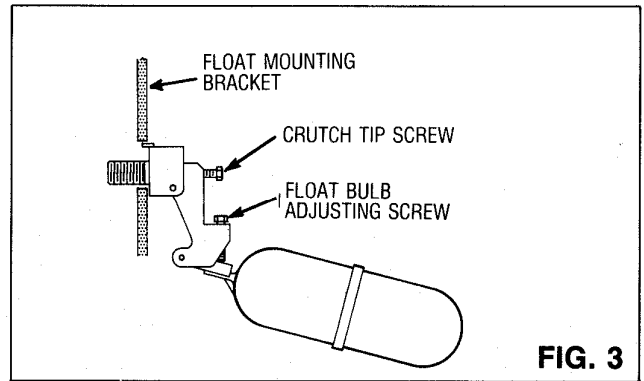
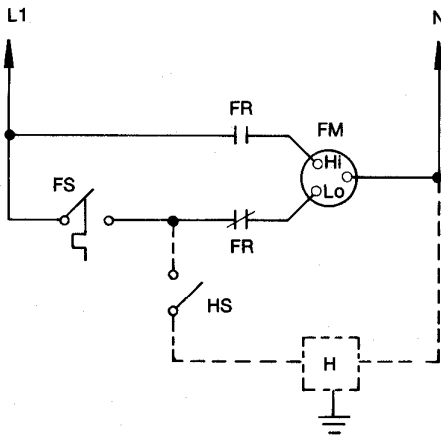
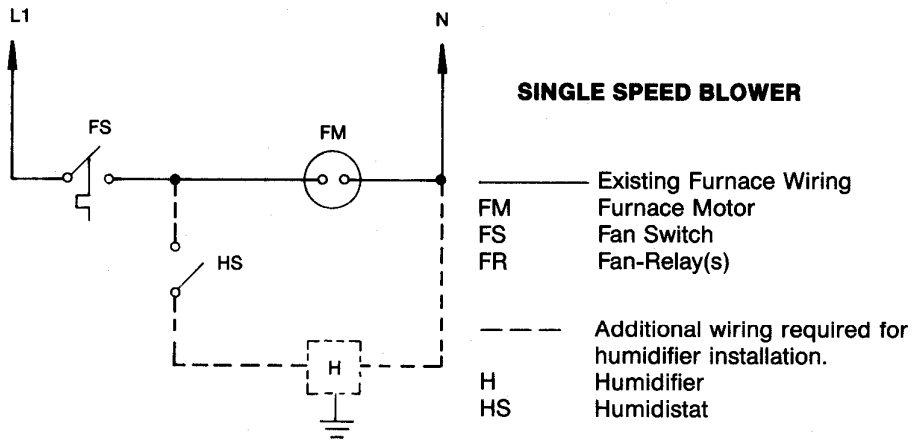

FIG. 3

WIRING DIAGRAMS

MODEL 40 and 40S

SINGLE SPEED BLOWER



MULTI-SPEED BLOWER WITH FAN-RELAY BETWEEN MOTOR AND FAN-SWITCH.

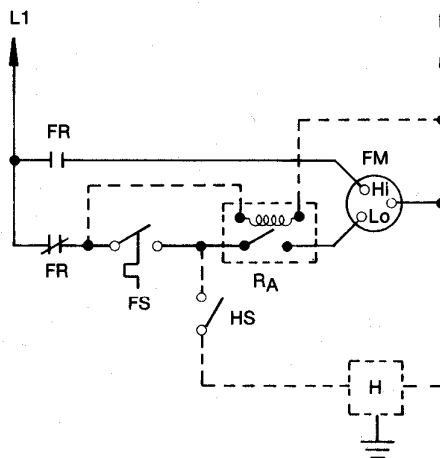

MULTI-SPEED BLOWER WITH FAN-SWITCH BETWEEN MOTOR AND RELAY.

Note: If you have this type of furnace we recommend the use of an additional relay (RA) wired as shown.

This relay should have a 120v coil with contacts sufficient to handle the starting load of the furnace motor.

This relay will prevent feed back from the low speed tap while in air conditioning mode.

SETTING THE HUMIDISTAT

The proper relative humidity for your home depends upon factors such as outdoor air temperature, type and placement of insulation, vapor barriers, effectiveness of weather stripping, type of windows and doors (including frames and jams) and whether or not storm windows and doors are used. With all these variables it is nearly impossible to recommend a proper humidity setting. The best humidistat setting is one that you are comfortable

with. Also, as the outdoor temperature fluctuates, it may be necessary to adjust the humidity level of your system a few times during the heating season.

Refer to the "Relative Humidity Chart" as a starting point for your proper humidistat setting. Generally, in a tighter and better-insulated house, the humidistat may be set higher than in a drafty, uninsulated house.

RELATIVE HUMIDITY CHART

Temperature Outdoors	Outdoor Relative Humidity	Indoor Relative Humidity	
		When Outdoor Air Is Heated To 72 Degrees F	Maximum Safe Recommended Indoor Relative Humidity
-10 Deg. F	40%	1%	20%
	60%	2%	
	80%	2%	
0 Deg. F	40%	2%	25%
	60%	2%	
	80%	5%	
10 Deg. F	40%	4%	30%
	60%	5%	
	80%	7%	
20 Deg. F	40%	6%	35%
	60%	8%	
	80%	11%	
30 Deg. F	40%	8%	35%
	60%	13%	
	80%	17%	

DO NOT OVER-HUMIDIFY

As you know, cold air cannot hold as much moisture as warm air. Any cold drafts or cold-faces such as windows and doors (including frames and jams) may cause water vapor to condense at these points. Also, if your home is well insulated and weather stripped but lacks effective

vapor barriers, water may seep through the walls and ceilings. This moisture may condense either inside or on the outside of walls or in the attic. If any of these conditions are observed the humidity should be reduced before water damage occurs.

TROUBLESHOOTING GUIDE

Your AutoFlo Model 40 Humidifier is designed to be trouble-free. However, the Troubleshooting Guide is provided in the event that you encounter operating problems either initially or after your unit has been in service. All replacement parts mentioned below are available from your AutoFlo dealer.

1. NOT GETTING ENOUGH HUMIDITY

An open fireplace damper or windows or doors will reduce the relative humidity in your home. Also, if your home was very dry when the humidifier was

placed into service it may take a few days or even weeks to reach a comfortable relative humidity level.

Open the service door while the furnace fan is operating. **BE CAREFUL BECAUSE THERE IS A ROTATING FAN ATTACHED TO THE DOOR.** Verify that the fan is rotating and water is dripping into the media pad from all six (6) holes of the water trough.

Check to see if the evaporative pad is clogged with minerals and replace if necessary.

If the fan is not rotating *and* water is not flowing, proceed as follows:

Note: It is normal for the humidifier to receive power only when the furnace blower is activated by the heating portion of your furnace. The humidifier will not receive power when the fan is operated by the cooling (or air conditioning) section of your system. Also, depending upon how the thermostat is connected, the humidifier may or may not receive power by activating the fan manually at the thermostat.

Check to see if the humidistat is turned on.

Models 40 and 40S are probably not receiving power from the furnace. A qualified installer should be consulted to determine which connections or control components are at fault.

If water is flowing but the fan is not rotating, the fan motor needs replacement.

If no water is flowing but the fan is rotating, proceed as follows:

- a. Close and fasten the service door.
- b. Check to be sure the saddle valve is turned on.
- c. If the valve is open **TURN OFF THE POWER TO THE HUMIDIFIER** and remove the control compartment cover located on the left side of the humidifier.
- d. For "Recirculating Units" only, check to see that the float is adjusted properly. Return power to the humidifier and verify that the pump motor is rotating. If it is not rotating, the "Pump Assembly" needs replacement. If this is a new installation and the pump motor is rotating but not pumping water, make sure the humidifier is receiving at least 110 volts. If not, find a 110 volt potential and rewire the humidifier.
- e. If water still does not flow, the water line or a valve may be blocked. **TURN OFF THE POWER TO THE HUMIDIFIER.** Turn off the saddle valve and disconnect the water supply tubing at the humidifier. With the loose end of the tubing pointing towards the bottom of the water pan, turn on the saddle valve. If water flows into the water pan, shut off the saddle valve. If water does not flow, the saddle valve or line is blocked.

To clean the saddle valve, **TURN OFF THE MAIN WATER SUPPLY**, remove the handle assembly by using a wrench on the packing nut and unscrewing the assembly. With a piece of wire (such as a straightened paper clip) remove any build-up inside the valve. Reassemble the valve and connect the water line to the humidifier. Turn on the main water supply and the saddle valve. Water should now flow to the humidifier.

- f. For "Solenoid Units" only, if water flows from the water supply tubing but does not flow into the trough, the solenoid is either blocked or has malfunctioned.

To service the solenoid valve **MAKE SURE THE POWER TO THE HUMIDIFIER IS TURNED OFF.** First make a sketch of or mark where the solenoid wires are attached to the terminal block and then remove them. Disconnect the tubing from the outlet of the solenoid and remove the solenoid valve assembly. There is a small plastic orifice on the outlet side of the solenoid. *Do not lose the orifice.* There is a filter screen inside the brass elbow inlet fitting of the solenoid assembly. Remove this inlet fitting and clean the screen. Reassemble the solenoid assembly using pipe dope or teflon tape on the elbow fitting.

Reassemble the humidifier (don't forget the orifice) and the water should flow. If water still does not flow the solenoid should be replaced.

Note: If the solenoid's filter was found to have been plugged, we recommend that an in-line filter be installed in the water line. Install this filter in an accessible location so it, rather than the solenoid, can be serviced the next time.

Turn on the main water supply and the saddle valve and check for leaks. Replace the control compartment cover.

2. IN THE EVENT OF WATER LEAKS:

- a. Leaks around the nut connections can be eliminated by tightening the nut. With the water on, tighten only enough to stop the leak and do not over-tighten.
- b. If leaking occurs around the float valve be sure the float is adjusted properly.

If the water continues to flow after adjusting the float valve the rubber seat or the nozzle tip may be worn out. An entire "Float Assembly" or a crutch tip is available from your AutoFlo dealer.

MAINTENANCE

All power humidifiers require some maintenance to keep them operating at peak performance. The AutoFlo Model 40 series humidifiers have been designed to simplify this required maintenance. Routine maintenance of your AutoFlo Model 40 humidifier should include the following three procedures.

1. Periodic replacement of evaporative pad.
2. An occasional cleaning of the water distribution trough and water pan.
3. An annual cleaning, general inspection, oiling of the fan motor and shut-down of the unit.

The evaporative pad should be replaced when it becomes clogged. The rate of evaporation depends upon the pad's surface area as well as the ability of air to pass through the pad. To remove the evaporative pad, turn off the electric power to both the furnace and the humidifier. Open the service door, lift the pad while pulling the top towards you. If the pad is clogged replace it with a new AutoFlo #40EP (with pad holder) or #40PAD (pad only).

Cleaning the water pan and distribution trough occasionally will prolong the life of your evaporative pad. To clean these areas, shut off the electric power to both the furnace and the humidifier. Shut off the water supply to the humidifier.

To clean the water pan remove the drain line from the water pan. Open the service door and locate the two thumb screws at the bottom front of the opening. When you remove these screws the water pan which is FULL OF WATER will be free to fall downward. With this in mind, hold the bottom of the pan with one hand and loosen the thumb screws with the other. While supporting the water pan with both hands, slide it forward and then lower it. Keep the water pan in a level position until the water can be dumped into a suitable receptacle.

Remove mineral deposits from the water pan. A mild detergent or vinegar and water solution is acceptable for cleaning the water pan and distribution trough. Also clean the pump housing and float.

When replacing the water pan, the float must be gently lifted into position. This will prevent damage or bending of the float assembly. The rear lip of the pan must also be fully engaged with the two support tabs at the lower rear of the humidifier housing. Reinstall the two thumb screws and, before adding any water, pull down on both rear corners of the pan. If any movement is detected the lip is not engaged with the rear supports. If necessary, remove the thumb screws and remount the water pan. Next attach the drain line.

Remove the water distribution trough cover by loosening the thumb screw on the top of the humidifier. Remove the cover and clean any mineral deposits from the trough and its six openings.

Turn on the water valve to the humidifier and check the float adjustment following the "Float Adjustment" section of this booklet.

Annual (Spring) shut-down should consist of an evaporative pad replacement, a thorough cleaning of the water pan and water distribution trough. After performing these procedures, leave the water and electrical power supplies to the humidifier off.

The fan motor should be lubricated annually. Add two (2) drops of S.A.E. 20 oil to each of the two oiling holes on the top of the fan motor.

To restart the humidifier in the fall, simply turn on the water and electrical power supplies to the humidifier. Adjust the humidistat and, for Recirculating Units, check the float adjustment.

autoflo[®]

MODEL 40

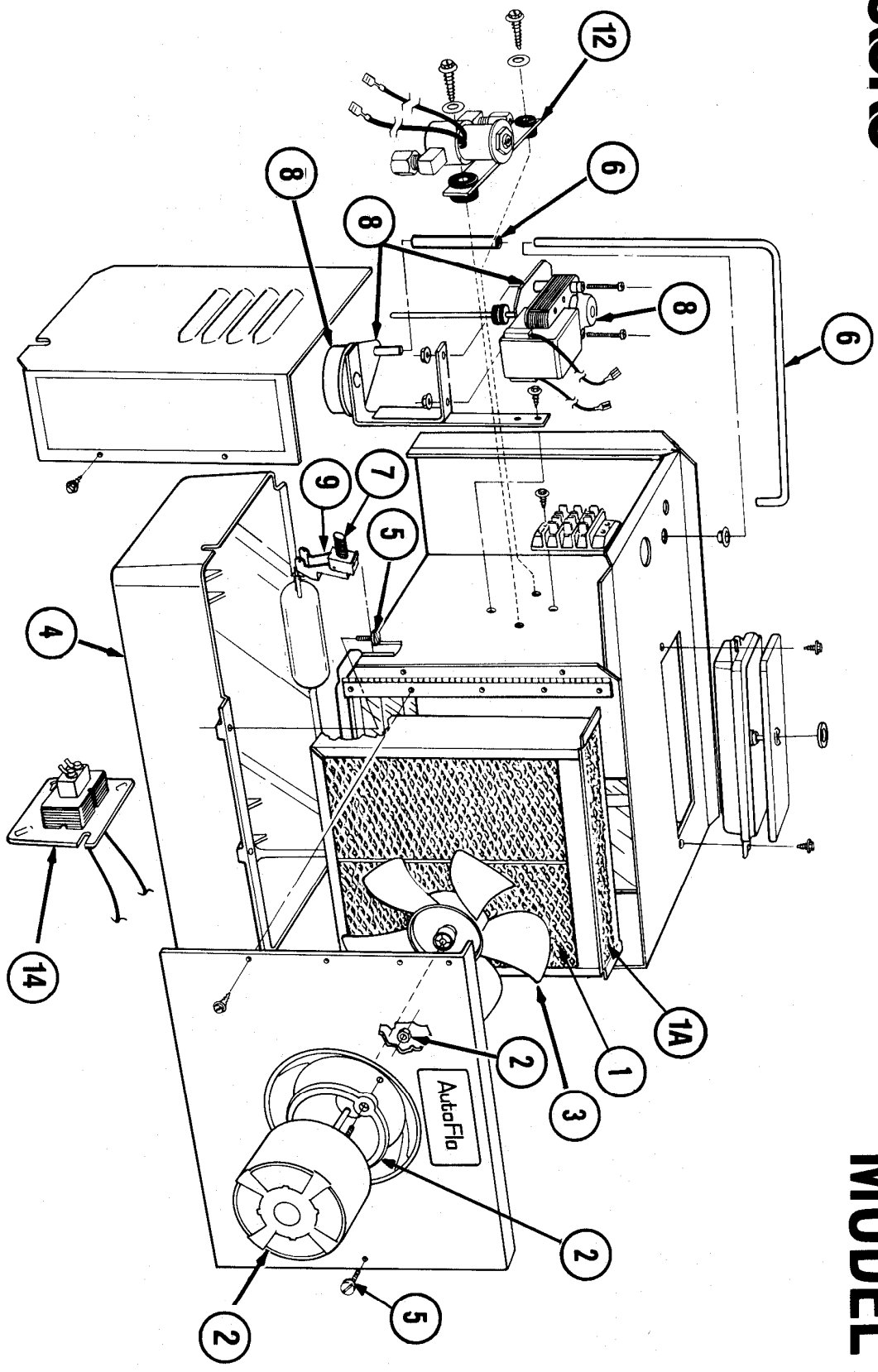

ALL VERSIONS

MODEL 40

Item #	Qty.	Description	Part #
1	1	Evaporative Pad Assy Consists of: 1 - Pad 1 - Frame	40EP
1A	1	Evaporative Pad Fan Motor Assembly Consists of: 1 - Gasket 1 - Motor - 120 Volt 2 - Nuts	40PAD 40410
3	1	Fan Blade	40460
4	1	Water Pan	40910
5	1	Door & Water Pan Hardware Consists of: 1 - Door Latch Hardware 2 - Water Pan Screws	401490

MODELS 40 & 40W

Item #	Qty.	Description	Part #
6	1	Water Line Assembly Consists of: 1 - Copper Water Line 1 - 3/8" Rubber Tubing	025170
7	1	Orifice Assembly Consists of: 1 - Orifice 1 - Lock Nut	010531
8	1	Complete Pump/ Motor Assembly Consists of: 1 - Motor - 120 Volt 1 - Splash Shield 1 - Slinger 2 - Nuts 2 - Bolts	040610
9	1	Complete Float/ Orifice Assembly Consists of: 1 - Float & Arm 1 - Crutch Tip 1 - Orifice Assembly Crutch Tip*	401972
10	1		401980

MODELS 40S & 40SW

Item #	Qty.	Description	Part #
11	1	Water Line Assembly* Consists of: 1 - 4" Copper Line 1 - Blue Orifice 1 - Nut & Sleeve	401491
12	1	Solenoid Assembly Consists of: 1 - Valve 1 - Screen 2 - Grommets 2 - Elbows	040260

MODELS 40W & 40SW

Item #	Qty.	Description	Part #
13	1	Relay*	040540
14	1	Transformer - 24V*	040560

* Not pictured