

This Owner's Manual is provided and hosted by [Appliance Factory Parts](#).



# AUTOFLO 400BP Owner's Manual

[Shop genuine replacement parts for AUTOFLO 400BP](#)



[Find Your AUTOFLO Humidifier Parts - Select From 42 Models](#)

----- Manual continues below -----

# Installation Instructions & Owner's Manual

## AUTOFLO MODELS 400BP and 800BP Power Humidifiers

FOR GAS OR OIL FORCED AIR FURNACES (NOT SUITABLE FOR HEAT PUMPS)

### OPERATION

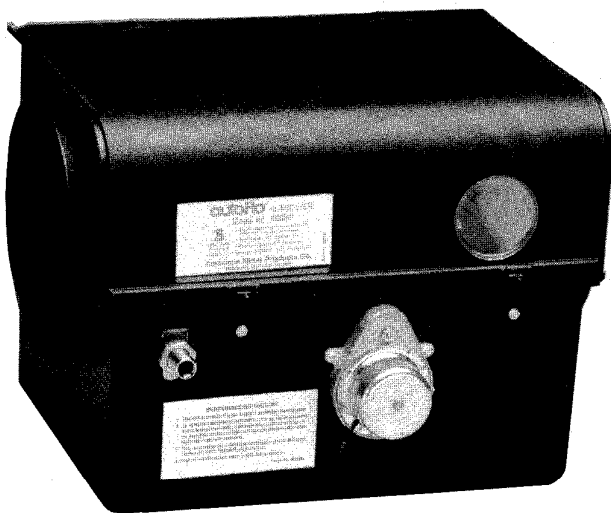

The AutoFlo Models 400BP and 800BP Humidifiers utilize the evaporative by-pass principal to add moisture into the return air duct of your central heating system. A by-pass humidifier depends upon the pressure difference between the warm air (supply) plenum and the cold air (return) duct of the furnace. This pressure differential causes a portion of the warm air to flow from the supply plenum through the humidifier and into the return duct.

The bottom section of the humidifier serves as a water reservoir. The water level in the reservoir is automatically controlled by a float valve assembly. A cylindrical media wheel is partially submerged in the water reservoir and partially exposed to the warm air flowing through the humidifier.

When the furnace blower is activated, the media wheel is rotated by a drive motor. Water is evaporated as the by-pass system forces warm air through the media wheel. When this moisture-laden air enters the return air duct it is mixed with the dry air flowing through the duct. This air mixture now has the correct moisture content to pass through the furnace and gradually increases the relative humidity within your home.

### WHAT IS RELATIVE HUMIDITY?

Humidity level both inside and outside your home is expressed by the term "Relative Humidity." Relative humidity is the percentage (%) of water vapor within the air, compared to the total amount of water vapor the air is capable of absorbing. As an example, 50% relative humidity means that the air is holding half of the moisture it is capable of absorbing at the present temperature. At one extreme is 100% relative humidity. If this condition exists outdoors and condensation occurs, it is raining.

Warm air is capable of absorbing much more water vapor than cold air. When cold air is heated by your furnace it

does not necessarily lose moisture. You may wonder why air with a high relative humidity outdoors feels dry indoors after it is heated. This is because the warmer air can now hold much more moisture than it could when it was cold. Consequently the relative humidity may have dropped to an uncomfortably low level. Refer to the "Relative Humidity Chart" to determine the effects on relative humidity when air is heated to 72 degrees F.

The installation of an AutoFlo Humidifier will allow you to add moisture to heated air, thereby increasing its relative humidity.

# BENEFITS OF PROPER RELATIVE HUMIDITY

Some of the benefits of maintaining proper relative humidity are listed below.

You will feel warmer at a lower temperature (thermostat setting). This is because water evaporates more slowly from the skin in humid air, which gives a feeling of warmth. In drier air, water evaporates more rapidly, which cools and dries the skin.

Shocks from static electricity will be reduced. This is because static charges are normally grounded through

the moisture in the air. With a low relative humidity there is insufficient moisture to ground all the static charges. In very dry air the only way these charges can be grounded is through a conductor such as a person touching a metal object, resulting in a shock.

Shrinking and warping of woodwork and furniture will be reduced. A proper relative humidity level also reduces splitting and cracking of wallpaper and helps carpeting and draperies retain their resiliency.

## PARTS LIST

Unpack the AutoFlo Humidifier and familiarize yourself with the following parts:

### PARTS INCLUDED

1. Model 400BP or 800BP Humidifier
2. Flexible By-Pass Duct, expandable to 2 feet
3. Small Parts Bag containing:
  - a. Four (4) #8 x 3/4 Sheet Metal Screws
  - b. Twelve (12) #8 x 3/8 Sheet Metal Screws
  - c. Rubber Overflow Plug
4. 24 Volt Transformer
5. End Cap
6. Baffle
7. Duct Adaptor

8. 1/4 inch Plastic Tubing
9. Saddle Tapping Valve Kit
10. Mounting Template
11. By-pass Adaptor Template

### ADDITIONAL RECOMMENDED PARTS

1. AutoFlo 24 volt Humidistat
2. Relay with 120 volt coil, for furnaces with multi-speed blower motors. (See "Electrical Connections" and "Wiring Diagrams" for details.)
3. Drain Tubing, 5/16 to 3/8 inch plastic or rubber tubing.
4. Electrical Wire and Enclosures for both line and 24 volt connections.

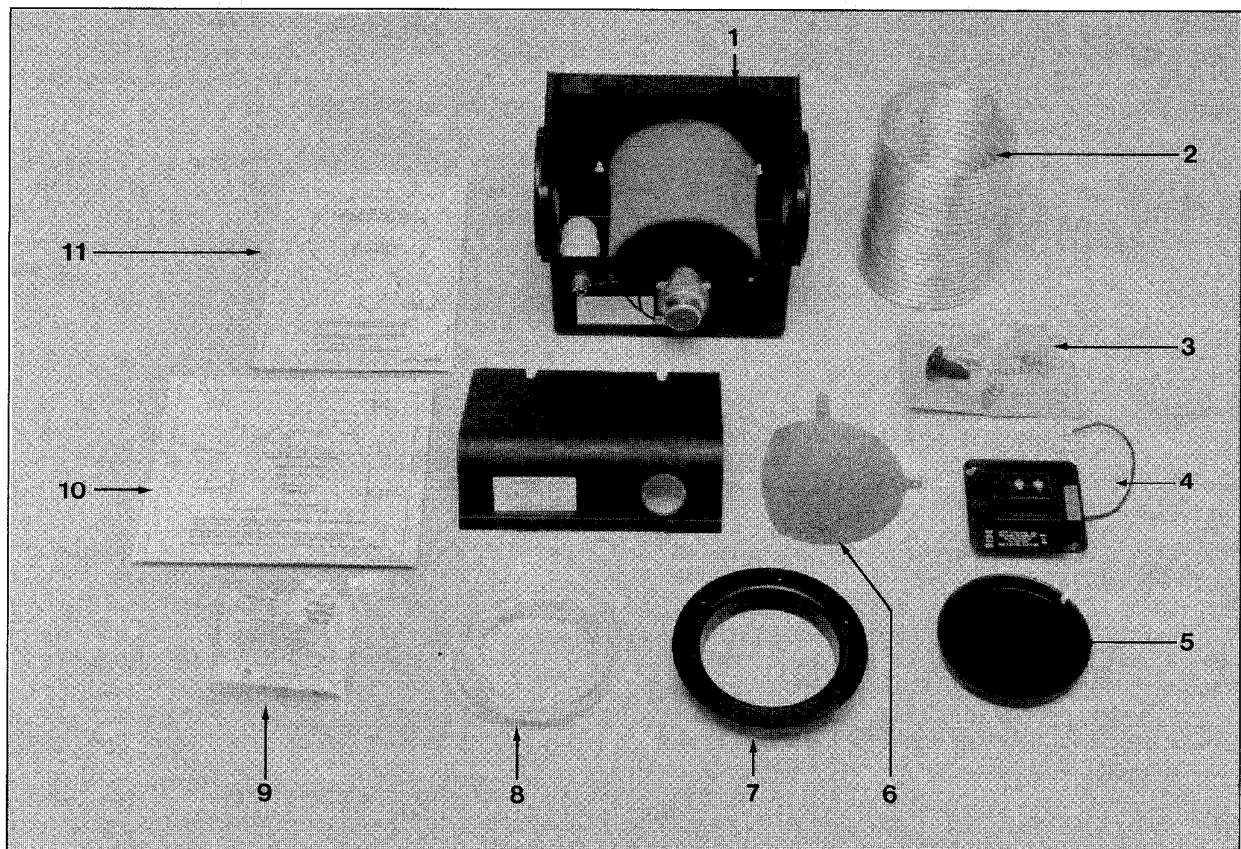

# RECOMMENDED LOCATION

The AutoFlo Model 400BP and 800BP Humidifiers are designed to be mounted on the side of a warm air plenum with the by-pass duct routed to the cold air return duct. The preferred position is to locate the humidifier as close as practical to the heating unit, downstream from the evaporator coil of the air conditioner system. The by-pass duct should be short as possible keeping offsets or turns to a minimum (Fig. 1, 2 or 3). Other optional installations will yield somewhat reduced but acceptable performance (Fig. 4 or 5).

The by-pass duct should *not* be routed across the front of the furnace. All furnace access doors and openings must remain unobstructed for proper furnace operation and servicing.

Refer to the rating plate label of the furnace for minimum clearances to combustible construction. The AutoFlo humidifier and all of its connections must be installed outside the minimum clearance requirements for rear, top, sides, front and flue of the furnace.

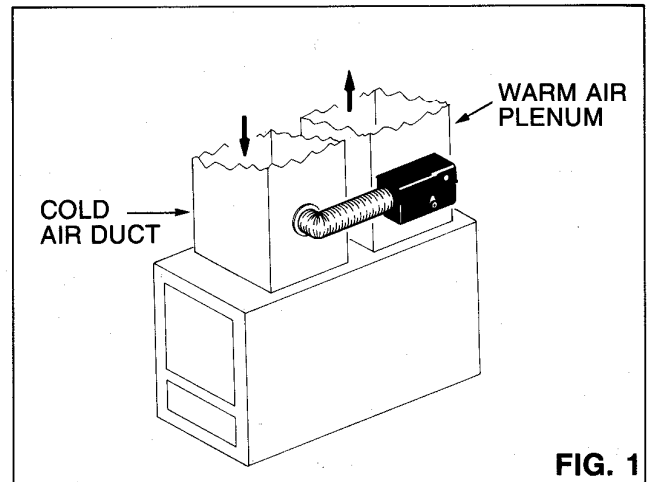

FIG. 1

Do not install where the humidifier or water connections may be exposed to freezing temperatures or outside weather.

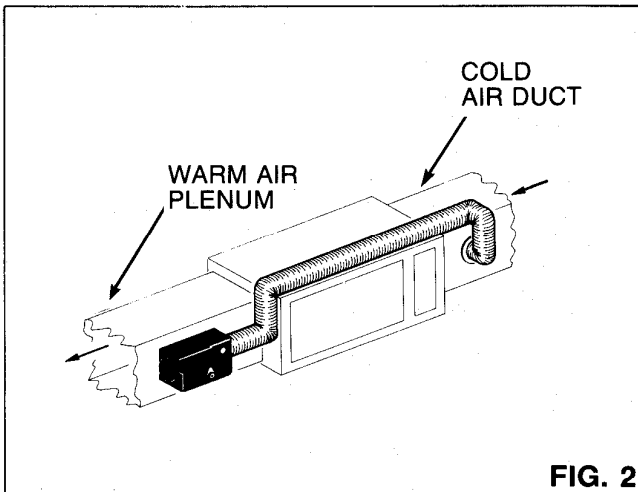

FIG. 2

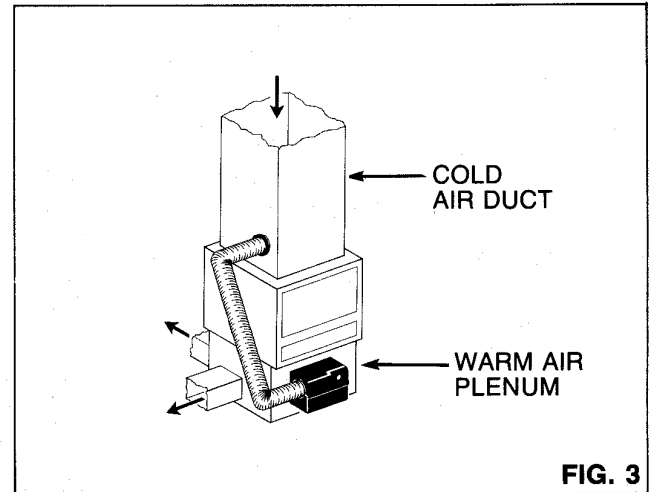

FIG. 3

# ALTERNATIVE LOCATIONS

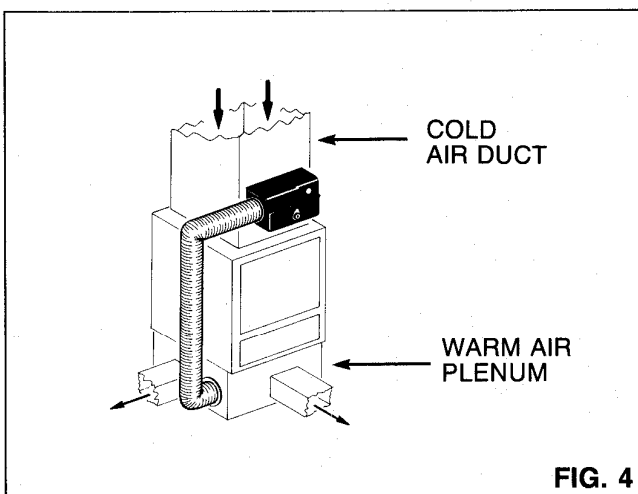

FIG. 4

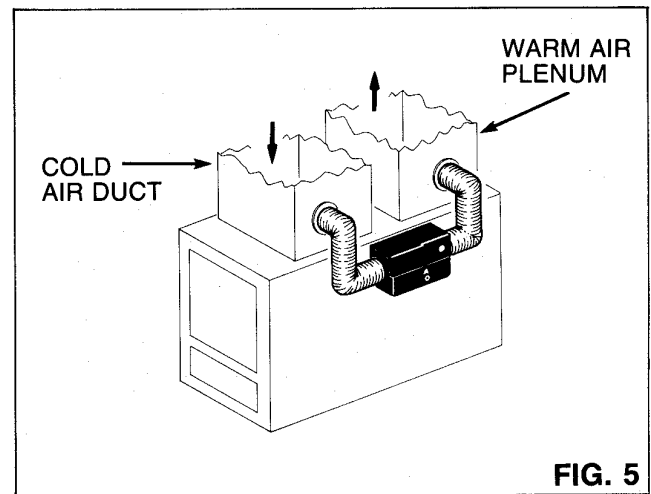

FIG. 5

# STEP BY STEP INSTALLATION

## 1. ATTACH TEMPLATES AND CUT OPENINGS

We recommend that you use leather gloves and protective eyewear while cutting and drilling sheet metal.

Tape the mounting template to the side of the warm air plenum. Use a level or plumb line to make sure the template is LEVEL. Before proceeding, verify that adequate clearances are available for servicing the media wheel. If necessary relocate the template.

Tape the by-pass adaptor template to the return duct. If possible, the sight or center line of the by-pass template should be level with the center line of the mounting template.

Extend (pull) and bend the by-pass duct and check to see if it will reach from the face of the by-pass template to the side of the mounting template. If the by-pass duct is not long enough, relocate the templates. If necessary, additional lengths of by-pass ducts are available from your AutoFlo dealer. If additional lengths are required, condensation within the duct may be reduced by wrapping the by-pass duct with insulation.

Drill ten (10) 1/8-inch holes as indicated on the templates.

Drill or punch a starter hole and then use a reciprocating saw or sheet metal shears to cut the openings as indicated on the templates. The mounting template requires a semi-circular shaped opening and the by-pass template requires a circular opening. Next, remove the templates and tape.

## 2. INSTALL HUMIDIFIER

Install the four (4) 3/4-inch long sheet metal screws half-way into the holes that were drilled through the mounting template. Remove the front cover and media wheel. Hang the humidifier from the four key hole slots on the rear of the humidifier. Tighten all four (4) screws.

## 3. INSTALL DUCT ADAPTOR

Mount the duct adaptor to the by-pass opening with two (2) 3/8-inch long sheet metal screws. Install the

baffle between the duct and the adaptor as shown in Fig. 6. The baffle should be open during the heating season and rotated to shut off the by-pass duct for air conditioner operation. Install and tighten the remaining three (3) 3/8-inch long sheet metal screws.

## 4. INSTALL BY-PASS DUCT AND END CAP

Route the flexible by-pass duct from the duct adaptor to the side of the humidifier. Drill two (2) holes through the by-pass duct and duct adaptor and install two (2) 3/8-inch long screws.

The flanges on both sides of the humidifier will accept either the by-pass duct or the end cap. Drill two (2) holes and install two (2) 3/8-inch long screws through the by-pass duct and into the humidifier flange.

Position the end cap over the flange on the opposite side of the humidifier. Drill two (2) holes and install two (2) 3/8-inch long screws through the end cap and flange.

## 5. OVERFLOW PLUG AND DRAIN CONNECTION

Insert the rubber overflow plug into the hole at the bottom right of the humidifier. The plug installs, from inside the humidifier, with the long end pointing out (Fig. 7).

We recommend that a drain line be used as an emergency overflow for the Models 400BP and 800BP Humidifiers. Use 5/16 to 3/8-inch outside diameter tubing. Hold the overflow plug in place and push the drain line into the bottom of the plug. Route and support the drain line on a continuous downward slope and into a suitable drain. Check to see if both the overflow plug and drain line are firmly seated.

## 6. WATER CONNECTION

Water for the humidifier must be taken from a nearby water line.

If this humidifier is installed in, above, or adjacent to a decorated living area, an emergency overflow pan (with a drain) should be installed below the humidifier.

Do not use any line connected to an air conditioner. Lines connected to air conditioners generally carry refrigerant and are not water lines.

Do not use any line which is served by a water softener. If your home has a water softener, make the water connection to a water line *upstream* from the water softener. A water softener is not a demineralizer. It merely exchanges various "hard ions" for "soft ions" in the water. These "soft ions," or minerals, will build up in the humidifier, causing a need for frequent servicing. The evaporation of softened water may also produce a white powder which may be carried into the duct system and, ultimately, into your home.

You have been supplied with 10 feet of plastic tubing for making the water connection. If more tubing is required, longer lengths of 1/4-inch O.D. plastic or copper tubing are available from your AutoFlo dealer.

Follow the instructions printed on the Saddle Tapping Valve Kit and install the valve. The valve should be

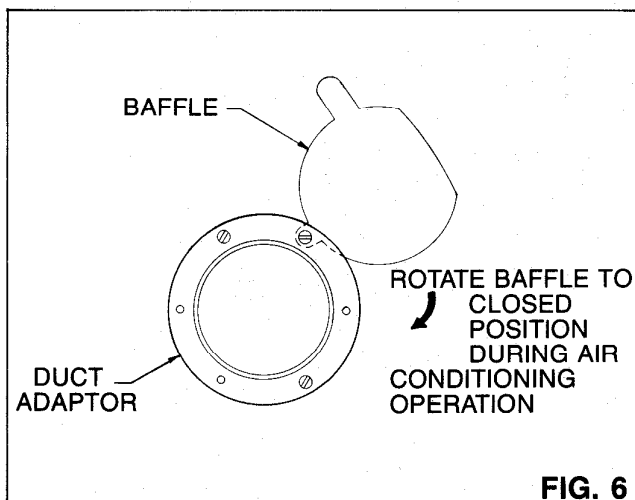

FIG. 6

mounted either on top of or on the side of a water line. If the valve is mounted on the bottom of the line, sediment in the water line will clog the valve.

### 7. FLOAT ADJUSTMENT

Remove the front cover and check the water level.

The float has been set at the factory for normal water pressure conditions. The float should completely shut off the water when the water surface is even with the step on the overflow plug (Fig. 7).

To adjust the float, loosen the large nut shown in Fig. 8. Slide the entire float valve assembly up to raise the water level or down to lower it. If additional adjustment is necessary, adjust the float bulb screw located on top of the float arm. Turn the screw clockwise to lower the water level and counterclockwise to raise the water level. Adjustment of the crutch tip screw is not recommended.

### 8. ELECTRICAL CONNECTIONS

The transformer should be wired in parallel with the furnace blower. This will allow the humidifier to run only when the furnace blower is operating. We recommend that an AutoFlo 24 volt humidistat be wired in series with the humidifier, on the secondary (24 volt) side of the transformer.

The transformer is designed to be attached to a metal 4 inch square electrical outlet box. The electrical box must be mounted and wired to the furnace blower in accordance with local building codes or the National Electric Code.

**SHUT OFF THE POWER TO THE FURNACE BEFORE PROCEEDING.**

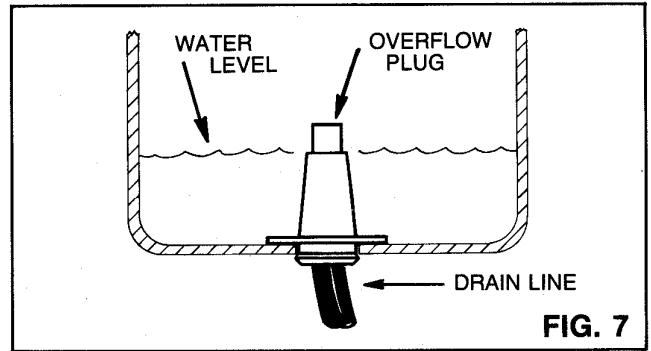

**FIG. 7**

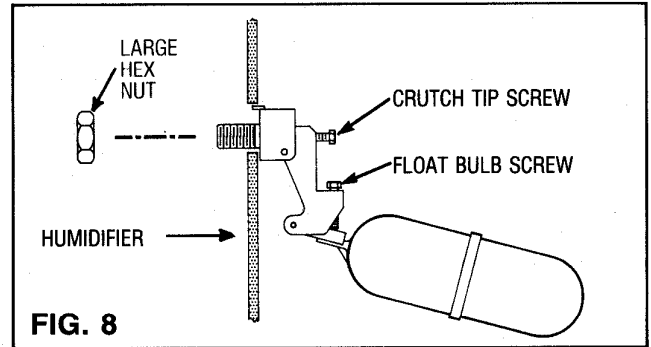
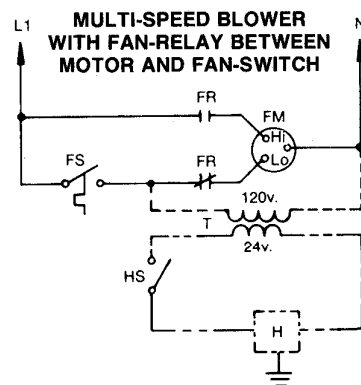
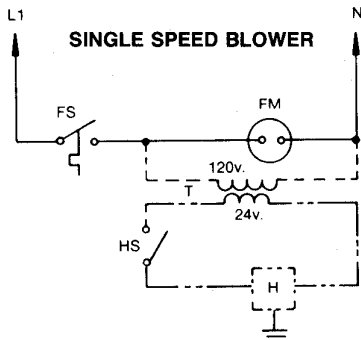

**FIG. 8**

Compare the wiring diagrams in these instructions to those of your furnace and determine where connections will be made.

**IF YOU HAVE ANY DOUBT ABOUT YOUR ABILITY TO PROPERLY WIRE THIS UNIT, WITHOUT DEFEATING ANY SAFETY CONTROLS OF YOUR FURNACE, A QUALIFIED ELECTRICIAN SHOULD BE CONSULTED.**

## WIRING DIAGRAMS



— Existing Furnace Wiring  
 FM Furnace Motor  
 FS Fan-Switch  
 FR Fan-Relay

- - - Additional wiring required for humidifier installation.  
 H Humidifier  
 HS Humidistat  
 T Transformer  
 - - - Low voltage wiring

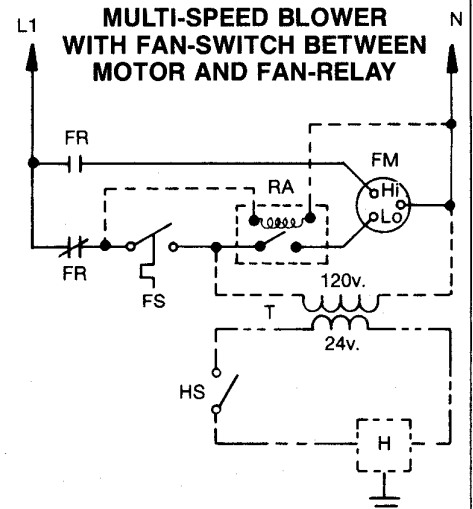

**NOTE:** If you have this type of furnace we recommend the use of an additional relay (RA) wired as shown. This relay should have a 120v. coil with contacts sufficient to handle the starting load of the furnace motor. This relay will prevent feedback from the low-speed tap during air conditioner operation.

Follow the instructions packaged with the AutoFlo humidistat and mount the humidistat.

Mount and connect the transformer.

When routing low voltage (24v) wiring, make sure it is routed outside the minimum required clearances specified on the furnace name plate label.

Route and support the low voltage wiring as shown in the Wiring Diagrams.

### 9. OPERATIONAL CHECK

Return the power to the furnace. Set the humidistat and the furnace thermostat to their highest settings. Verify that the humidifier media wheel is rotating when the furnace blower is activated. Set the humidistat and thermostat to the proper settings.

---

## SETTING THE HUMIDISTAT

---

The proper relative humidity for your home depends upon factors such as outdoor air temperature, type and placement of insulation, vapor barriers, effectiveness of weather stripping, type of windows and doors (including frames and jams) and whether or not storm windows and doors are used. With all these variables it is nearly impossible to recommend a proper humidity setting. The best humidistat setting is one adjusted to your comfort.

As the outdoor temperatures fluctuate, it may be necessary to adjust the humidity level of your system a few times during the heating season.

Refer to the "Relative Humidity Chart" as a starting point for your proper humidistat setting. In a tighter and better-insulated house, the humidistat may be set higher than in a drafty, uninsulated house.

---

## RELATIVE HUMIDITY CHART

---

Outside Temperature	Outside Relative Humidity	Indoor Relative Humidity When Outside Air Is Heated To 72 Degrees F	Maximum Safe Recommended Indoor Relative Humidity
- 10 Deg. F	40%	1%	20%
	60%	2%	
	80%	2%	
0 Deg. F	40%	2%	25%
	60%	2%	
	80%	5%	
10 Deg. F	40%	4%	30%
	60%	5%	
	80%	7%	
20 Deg. F	40%	6%	35%
	60%	8%	
	80%	11%	
30 Deg. F	40%	8%	35%
	60%	13%	
	80%	17%	

---

## DO NOT OVER-HUMIDIFY

---

As you know, cold air cannot hold as much moisture as warm air. Any cold drafts or cold-faces such as windows and doors (including frames and jams) may cause water vapor to condense at these points. If your home is well-insulated and weather-stripped but lacks effective vapor

barriers, water may seep through the walls and ceilings. This moisture may condense either inside or on the outside of walls or in the attic. If any of these conditions are observed, the humidity should be reduced before water damage occurs.

---

# TROUBLESHOOTING GUIDE

---

Your AutoFlo Model 400BP and 800BP Humidifiers are designed to be trouble-free. However, the following Troubleshooting Guide is provided in the event that you encounter operating problems either initially or after your unit has been in service.

## 1. NOT GETTING ENOUGH HUMIDITY

- a. Check for proper water level. If the water level is too low, it may be caused by one or more of the following conditions:

Check to see that the saddle valve is turned on.

Check to see that the float is adjusted properly.

If the unit has been in service for some time, a mineral build-up may be blocking the Saddle Valve. To clean the valve, TURN OFF THE MAIN WATER SUPPLY, remove the handle assembly by using a wrench on the packing nut and unscrew the assembly. With a piece of wire (such as a straightened paper clip) remove any mineral build-up inside the valve. Reassemble the valve, turn on the main water supply, and the water pan should fill.

- b. The media wheel is not rotating WHEN THE FURNACE BLOWER IS OPERATING.

Note: It is normal for the media wheel to rotate only when the furnace blower is activated by the heating portion of your furnace. The humidifier will not receive power when the fan is operated by the cooling (or air conditioning) section of your system. Depending upon how the thermostat is connected, the humidifier may or may not receive power by activating the fan manually at the thermostat.

The transformer or motor of the humidifier or the furnace controls or relays as well as any wire connections may be at fault. A qualified installer should be consulted to determine if 24 VAC is present at the humidifier motor and if line voltage is being supplied to the transformer. Replacement motors or transformers are available from your AutoFlo dealer.

- c. An open fireplace damper, windows or doors will reduce the relative humidity in your home. If your home was very dry when the humidifier was placed in service, it may take a few days or even weeks to reach a comfortable relative humidity level.

- d. Make sure the by-pass duct baffle is in the open position.

## 2. IN THE EVENT OF WATER LEAKS:

- a. Leaks around the nut connections can be eliminated by tightening the nut. With the water on, tighten only enough to stop the leak and do not over-tighten.

- b. If leaking occurs around the float valve, be sure the float is adjusted properly.

If the water continues to flow after adjusting the float valve, the rubber seat or the nozzle tip may be worn out. An entire "Float Assembly" and crutch tip is available from your AutoFlo dealer.

---

# MAINTENANCE

---

All power humidifiers require some maintenance to keep them operating at peak performance. The AutoFlo Model 400BP and 800BP Humidifiers have been designed to simplify this required maintenance. Routine maintenance of your Humidifier should include the following three procedures:

1. Periodic replacement of evaporator pad.
2. An occasional cleaning of the water reservoir.
3. An annual cleaning, general inspection, and shut-down of the unit.

The evaporator pad should be replaced with an AutoFlo factory replacement pad when it becomes clogged or brittle. The rate of evaporation depends upon both the surface area of the pad as well as the ability of air to pass through the pad. To remove the evaporative pad, turn off the electric power to both the furnace and the humidifier. Open the service door and lift the rear of the wheel. Disengage the front of the wheel from the motor and lift the wheel and pad up and out.

Remove mineral deposits from the water pan. A mild detergent or vinegar and water solution is acceptable for cleaning the water pan.

Turn on the water valve to the humidifier and check the float adjustment following the "Float Adjustment" section of this booklet.

Annual (Spring) shut-down should consist of replacing the evaporator pad, thoroughly cleaning the water reservoir and rotating the by-pass baffle to the closed position. After performing these procedures, leave the water and electrical power supplies to the humidifier in the OFF position.

To restart the humidifier in the fall, turn on the water and electrical power supplies to the humidifier. Adjust the humidistat, check the float adjustment and rotate the by-pass baffle to the OPEN position.

## One-Year Limited Warranty

All parts of the AUTOFLO® Humidifier, except the evaporative pads, plates, discs or foam, are warranted to the original consumer purchaser to be free from defects in material and workmanship for a period of one (1) year from date of purchase as shown on purchaser's receipt.

AutoFlo will replace FREE OF CHARGE, during the warranty period, any warranted part which proves defective in material and/or workmanship under normal installation, use, and service. Replacement parts can be obtained from your local dealer or distributor or by returning the part, TRANSPORTATION CHARGES PREPAID, to our Service Center. Any injury to this humidifier as a result of misuse, abuse, neglect, accident, improper installation, or any other use violative of instructions furnished by us, WILL VOID THE WARRANTY. THIS WARRANTY IS LIMITED TO DEFECTIVE PARTS REPLACEMENT ONLY. LABOR CHARGES AND/OR DAMAGE INCURRED IN INSTALLATION OR REPLACEMENT AS WELL AS INCIDENTAL AND CONSEQUENTIAL DAMAGES CONNECTED THEREWITH ARE EXCLUDED.

Some states do not allow the exclusion or limitation of incidental or consequential damages, so the above limitation or exclusion may not apply to you.

This warranty gives you specific legal rights, and you may also have other rights which vary from state to state. In the event of a problem with warranty service or performance, you may be able to go to a small claims court, a state court, or a federal district court.

autoflo®

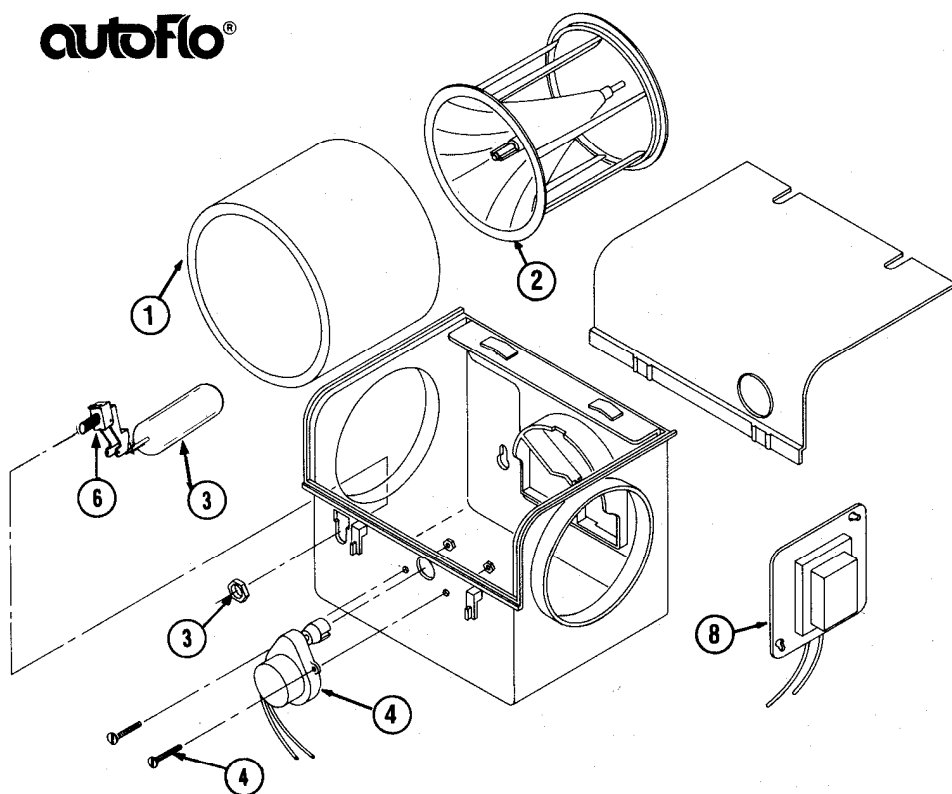

## MODEL 400BP & 800BP

Item#	Qty.	Description	Part #
3	1	Complete Float/ Orifice Assembly Consists of: 1 - Crutch Tip 1 - Float & Arm Assy. 1 - Orifice Assembly	401972
4	1	Motor Assembly Consists of: 1 - 24V Motor 2 - Screws 2 - Nuts 2 - Spacers	20028
5	1	Rubber Overflow Plug*	401492
6	1	Orifice Assembly Consists of: 1 - Orifice 1 - Lock Nut	010531
7	1	Crutch Tip*	401980
8	1	Transformer	20022
*Not Pictured			

### MODEL 400BP

1	Evaporative Pad	450EP
2	Pad Holder	401161

### MODEL 800BP

1	Evaporative Pad	200EP
2	Pad Holder	27200

ORDER PARTS: 800/323-0620



# STEP BY STEP INSTALLATION

## 1. ATTACH TEMPLATES AND CUT OPENINGS

We recommend that you use leather gloves and protective eyewear while cutting and drilling sheet metal.

Tape the mounting template to the side of the warm air plenum. Use a level or plumb line to make sure the template is LEVEL. Before proceeding, verify that adequate clearances are available for servicing the media wheel. If necessary relocate the template.

Tape the by-pass adaptor template to the return duct. If possible, the sight or center line of the by-pass template should be level with the center line of the mounting template.

Extend (pull) and bend the by-pass duct and check to see if it will reach from the face of the by-pass template to the side of the mounting template. If the by-pass duct is not long enough, relocate the templates. If necessary, additional lengths of by-pass ducts are available from your AutoFlo dealer. If additional lengths are required, condensation within the duct may be reduced by wrapping the by-pass duct with insulation.

Drill ten (10) 1/8-inch holes as indicated on the templates.

Drill or punch a starter hole and then use a reciprocating saw or sheet metal shears to cut the openings as indicated on the templates. The mounting template requires a semi-circular shaped opening and the by-pass template requires a circular opening. Next, remove the templates and tape.

## 2. INSTALL HUMIDIFIER

Install the four (4) 3/4-inch long sheet metal screws half-way into the holes that were drilled through the mounting template. Remove the front cover and media wheel. Hang the humidifier from the four key hole slots on the rear of the humidifier. Tighten all four (4) screws.

## 3. INSTALL DUCT ADAPTOR

Mount the duct adaptor to the by-pass opening with two (2) 3/8-inch long sheet metal screws. Install the

baffle between the duct and the adaptor as shown in Fig. 6. The baffle should be open during the heating season and rotated to shut off the by-pass duct for air conditioner operation. Install and tighten the remaining three (3) 3/8-inch long sheet metal screws.

## 4. INSTALL BY-PASS DUCT AND END CAP

Route the flexible by-pass duct from the duct adaptor to the side of the humidifier. Drill two (2) holes through the by-pass duct and duct adaptor and install two (2) 3/8-inch long screws.

The flanges on both sides of the humidifier will accept either the by-pass duct or the end cap. Drill two (2) holes and install two (2) 3/8-inch long screws through the by-pass duct and into the humidifier flange.

Position the end cap over the flange on the opposite side of the humidifier. Drill two (2) holes and install two (2) 3/8-inch long screws through the end cap and flange.

## 5. OVERFLOW PLUG AND DRAIN CONNECTION

Insert the rubber overflow plug into the hole at the bottom right of the humidifier. The plug installs, from inside the humidifier, with the long end pointing out (Fig. 7).

We recommend that a drain line be used as an emergency overflow for the Models 400BP and 800BP Humidifiers. Use 5/16 to 3/8-inch outside diameter tubing. Hold the overflow plug in place and push the drain line into the bottom of the plug. Route and support the drain line on a continuous downward slope and into a suitable drain. Check to see if both the overflow plug and drain line are firmly seated.

## 6. WATER CONNECTION

Water for the humidifier must be taken from a nearby water line.

If this humidifier is installed in, above, or adjacent to a decorated living area, an emergency overflow pan (with a drain) should be installed below the humidifier.

Do not use any line connected to an air conditioner. Lines connected to air conditioners generally carry refrigerant and are not water lines.

Do not use any line which is served by a water softener. If your home has a water softener, make the water connection to a water line *upstream* from the water softener. A water softener is not a demineralizer. It merely exchanges various "hard ions" for "soft ions" in the water. These "soft ions," or minerals, will build up in the humidifier, causing a need for frequent servicing. The evaporation of softened water may also produce a white powder which may be carried into the duct system and, ultimately, into your home.

You have been supplied with 10 feet of plastic tubing for making the water connection. If more tubing is required, longer lengths of 1/4-inch O.D. plastic or copper tubing are available from your AutoFlo dealer.

Follow the instructions printed on the Saddle Tapping Valve Kit and install the valve. The valve should be

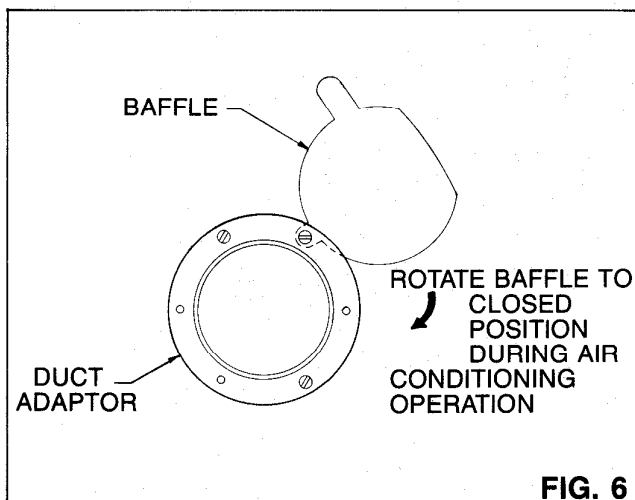

FIG. 6