

This Owner's Manual is provided and hosted by [Appliance Factory Parts](#).



HERRMIDIFIER 447-C1 Owner's Manual

[Shop genuine replacement parts for HERRMIDIFIER
447-C1](#)



[Find Your HERRMIDIFIER Humidifier Parts - Select From 41 Models](#)

----- Manual continues below -----

447-C1

Duct Mount Humidifier



Manual for:
Installation - Operation - Maintenance

Caution: Read installation and rules carefully for safe operation.
Exercise the usual precautions when working with electricity

TRION[®]

Table of Contents	Page
Introduction	1
Specifications	4
Operation of Humidifier	5
Maintenance	6
Installation	
Physical Installation	8
Electrical Installation	11
Unit Diagram and Parts List	13

Dear Owner:

Congratulations on your choice of a Trion humidifier. Your family can now look forward to breathing more comfortable air, winter after winter. We know, because we have been engaged in the design and production of humidification equipment for home and industry for over 50 years. Today, as then, we are committed to providing advanced products that improve the quality of the air you breathe.

The following information will familiarize you with the operation of your new humidifier and provide helpful tips on how to obtain maximum performance from your unit.

INTRODUCTION

All humidifiers, air conditioners, refrigerators and dehumidifiers require periodic cleaning and maintenance to insure efficient and safe operation.

The benefits of a properly humidified environment (35-50%) are enjoyed by everyone living in such an comfortable environment. These benefits include both personal comfort and the preservation of furniture, draperies, carpets, wooden floors and cabinets, paintings, pianos, etc. - all hygroscopic materials. A hygroscopic material is one that has the ability to give up or absorb moisture. Your home will be more comfortable at a lower temperature (i.e.: 68° F) at 30-40% Relative Humidity (RH) than at 71° to 72° F without controlled humidity. Since every degree of temperature setback represents about 3% of your heating costs, this can represent a possible 9-12% annual saving.

During the heating season, cold air is brought into the house and heated. When heated, this air dries out and greatly increases its capacity to hold more moisture. By using a humidifier, we provide a source of water to satisfy this increased moisture holding capability, rather than having it drawn from our body surface and the surrounding hygroscopic furnishings in the home.

With the energy crisis of the mid-70's, home builders and owners have become more conscious of energy conservation. To conserve energy, homes have become tighter in construction to provide less infiltration of cold outside air and less exhaust of heated inside air. This has been accomplished by using more insulation, tighter storm windows, weather stripping and being more personally conscious of tightly closing doors and windows in general.

This tighter environment in which we now live is also a more stagnant environment and has brought about an increasing concern about "Indoor Air Quality." The air in the home is not being allowed to change as frequently.

As stated, a properly maintained and efficiently operating humidifier is a source of improved Indoor Air Quality and personal comfort. The necessity to clean your humidifier is substantially the result of impurities coming in through your water supply which feeds the humidifier. Other household dust, containing biological and microbial contaminants, finds its way into the air handling system and ultimately, the humidifier.

The humidifier is not the source of these impurities.

To enjoy the benefits of a properly humidified environment, periodic cleaning is necessary to control both water and household impurities. Film or scum, which can contain bacteria or fungi, may appear on the water surface, the sides, or bottom of your humidifier. A crusty deposit or scale may also appear and is composed of minerals that have settled out of the water.

To improve the efficiency of your humidifier, and to reduce the possibility of a health hazard, it is recommended that you take the following precautions:

- Follow the manufacturer's recommended cleaning and maintenance instructions.
- The amount of minerals and other impurities in a water source can vary greatly and hence, the frequency of cleaning also varies.
- During the heating season, check for film or scale build-up on a monthly basis and establish a proper cleaning schedule.
- Do not allow film or scale to build up on the unit, evaporator pad, or any moving part and reduce the efficiency of the humidifier.
- An algaecide, such as a humidifier cleaning tablet or bacteriostatic liquid/powder, can be used to combat algae build-up, should it become evident.
- At the end of the winter humidification season, drain and thoroughly clean your humidifier as part of the summer shut down.

Like your heating system and air conditioning unit, periodic maintenance and cleaning are required to ensure the safe and efficient operation of your humidifier. This cleaning necessity is also likened to weekly house cleanings and periodic maintenance of your automobile for its safe and efficient operation.

SPECIFICATIONS

447-C1	
Type of Unit	Rotating Drum
Duct Mounting	Return Supply
GPD @ 140° F	13.8 10.3
GPD @ 120° F	10.7 7.9
GPD @ 100° F	7.0 5.0
Voltages	24V
Unit W x D x H	12 ³ / ₄ " x 9 ⁵ / ₁₆ " x 9"
Duct Opening W x H	8 ³ / ₄ " x 2 ⁷ / ₈ "
Shipping Weight	6 lbs.
Standard Equipment	Wall/duct mounted humidistat Self-piercing saddle valve 6" flange & damper
Features	Externally held evaporative media Independent mounting bracket Right or left hand discharge All brass valve assembly Simple, no tools maintenance Stainless steel cage Large observation window 2 Year Warranty

OPERATION OF HUMIDIFIER

This 447-1/447-C1 humidifier operates on the silent principle of evaporation. When your unit is operating properly, you may observe the drum turning freely by looking through the observation window. Evaporation takes place as the air passes through the moistened evaporator pad held in place by the specially engineered rotating drum assembly. Operation is completely automatic, working in conjunction with the heating system blower. A portion of the warm air is bypassed through the humidifier for quiet and economical humidification of the air in your home. The humidifier is designed for use with either hard or softened water.

Set the humidistat in the recommended range of 30-50% relative humidity for automatic humidity control during the heating season (a lower setting may be used to control condensation on single pane windows). During the first heating season, check the mineral build-up every month to establish the proper cleaning schedule. Clean the unit at the end of each heating season or whenever mineral deposits appear to clog the openings in the evaporator pad

You can easily check your humidifier to be sure it is in working condition. Simply turn the humidistat to a higher setting and look through the observation window (a flashlight may be needed). If the unit is working properly, the evaporator pad will be rotating. Be sure to set the humidistat back to the desired level.

For shutting the humidifier down for the summer months, start with cleaning any mineral accumulation from the unit. Leave the water turned off and the unit dry. Turn the humidistat to the OFF position and remove the entire evaporator pad and cage assembly if central air conditioning equipment is to be used.

At the beginning of the heating season, return the entire evaporator pad and cage assembly to its original location. Trion recommends that you replace the evaporator pad each heating season. Turn on the water, check the water level within the humidifier and return the humidistat to the desired level.

MAINTENANCE INSTRUCTIONS

Periodic cleaning is required for the efficient and safe operation of this humidifier. Inspect the humidifier approximately once a month for mineral and algae growth. Algae may develop inside the humidifier if certain conditions exist in the water supplying the unit. Algae is a slimy substance which can be green, brown or white. It is advisable to add an algaecide to the water on a weekly basis. This algaecide can be 10 drops of bleach or Trion humidifier tablets purchased through your local Trion dealer. Periodic cleaning and removal of accumulated mineral deposits and algae growth will be the only maintenance this unit requires. The frequency of this maintenance will depend on the mineral content, or hardness, of the water being supplied to the humidifier.

To inspect the unit:

1. Turn the power to the furnace OFF.
2. Set the humidistat to the OFF position and disconnect the humidifier from the power source.
3. Turn off the water at the saddle valve by turning clockwise.
4. Remove the (2) stainless steel clips on either side of the humidifier and remove the top of the humidifier.

To clean the unit:

1. If the evaporator pad appears clogged with mineral deposits, remove the drain plug and drain the water from the unit.
2. Disconnect the overflow drain line.
3. Carefully remove the pad by lifting the drum end opposite the motor and pulling away from the motor.
NOTE: Do not rotate the cage or damage to the motor gear train will occur.
4. Remove the safety clips from between the pan and mounting plate. Lift up on the pan and pull the bottom away from the duct.
5. Lower the pan to free it from the mounting plate.
6. Dump any accumulated sludge or slime from the pan. Clean thoroughly using a 50/50 solution of white vinegar and water or Trion liquid humidifier cleaner. Rinse with clean water.

7. Remove the evaporator drum end by squeezing the wires located at the loop end.
8. Coil the evaporator pad to free it from the wire cage.
9. Install the new evaporator pad by reversing the previous procedure. Uncoil and butt the ends together.
10. Replace the drain plug and reinstall the cage and pad assembly into the humidifier.
11. Reinstall the pan to the duct by tilting it to engage the back edge of the opening under the tangs. Lower the front edge to the level position and engage the (2) pins (located on the sloped bottom) into the matching holes on the mounting plate.
12. Slide the safety clips over the tangs to lock the humidifier securely to the mounting plate.
13. Reconnect the overflow drain line and turn on the water at the saddle valve by turning counter-clockwise.
NOTE: A red & white label in the pan shows the proper water level.
14. Turn the humidistat to the desired humidity level.

INSTALLATION INSTRUCTIONS

PHYSICAL INSTALLATION

Remember to select a location that is readily accessible for periodic inspection and cleaning of your humidifier. This unit should be located on the cold air return side of the system for best results. However, if space does not permit, it can be located on the warm air supply side of the system. Please keep in mind that the evaporative capacity of the humidifier will be reduced if this alternate installation method is utilized.

CAUTION:

Only a trained service person should install this humidifier. Do not connect the unit to power source until installation is complete. A thorough checkout of the unit installation should be completed before operation. Failure to follow these directions may void the manufacture's original warranty.

Prior to installing this product...

1. Read the instructions carefully to ensure safe operation. Failure to follow them could damage the product or cause a hazardous condition.
2. Check the ratings given on the product to make sure it is suitable for your application.
3. Level and attach the mounting template to the selected location.
4. Drill $\frac{1}{8}$ " diameter holes and cut the opening as marked on the template. Remove the template from the duct.
5. Cut holes in the opposite air duct and drill the holes for screws, using the flange as a template. Install a damper if needed.
6. Screw the mounting plate to the air duct. Use the sheet metal screws and spring locknuts provided.
7. Position the shelf of plate at the bottom.
8. The humidifier may be hung with the outlet flange to the left or right as required. Install the pan of unit on the mounting plate by tilting to engage the back edge of opening under the tangs.
9. The humidifier may be hung with the outlet flange to the left or right as required. Install the pan of unit on the mounting plate by tilting to engage the back edge of opening under the tangs.

10. Lower the front to a level position and engage the (2) pins located on the sloped bottom into the matching holes on the mounting plate.
11. Slide the safety clips, provided, over the tangs to lock the unit securely to the mounting plate.
12. Slide the closed end of the drum assembly onto the motor shaft and place the other end in the "U" shaped holder.
NOTE: Do not use drum to turn the motor. Damage to the gears will result.
13. Install the humidistat based on the instructions located in the box.
14. Install the saddle valve using the instructions on the package and turn on the water supply.
15. Check for leaks in the piping.
16. If necessary, bend the float rod up or down to adjust the water level in the water reservoir pan.
NOTE: A red & white label in the pan shows the proper water level.
17. When installing this humidifier above electric warm air heating elements or where water damage could occur from accidental overflow, connect a 1/2" drain hose to the brass overflow.
18. Do NOT solder the line directly to the humidifier because heat can warp and damage the pan.
19. Turn the humidistat to the highest setting. If the humidifier is wired to the fan motor, ensure that the blower is turned on. The humidifier should run at this point and should stop when the humidistat is turned to a setting below 20%.
20. Install the inspection window on the top of the case in the proper position with regard to the discharge duct location used. The window can be located in either opening as required.
21. Slide the inspection window downward into the opening, making sure that it rest between the (3) locating tabs and the front frame.
22. The window is held in place by fastening the retaining frame to the (2) inside corners of the case top with (2) thread cutting screws inserted into the (2) holes on the inside corners.
23. Install the top and secure the front corners with the clips provided. Ensure that the back corners of the case are under the hold down tabs on the mounting plate.

24. Use 5" diameter flexible or metal duct (not provided) to connect the bypass from the unit to the supply air flange.
25. If flex duct is used, engage one or two coils of flexible duct wires behind (3) lugs located on the inside of the unit bypass opening.
26. (2) hose clamps are required and the bypass duct should be level for best results.
NOTE: Installation kit contains 25' of 5" flex duct and (12) adjustable duct clamps. Contact your distributor for more information.
27. Set the furnace controls and humidistat for desired conditions. Operation is automatic.

ELECTRICAL INSTALLATION

This humidifier is intended to be wired independently of the integrated control panel on your furnace. This will provide power to the humidifier at all times, causing the evaporator pad to turn constantly.

Read the instructions in the furnace installation manual carefully before attempting installation or operation. Failure to follow these instructions may result in improper installation and therefore, void the manufacturer's warranty.

1. Turn the humidistat to the highest level (past 60%) and the humidifier should begin to run. The humidifier should stop when the humidistat is turned off.
2. Set the furnace controls and humidistat for the desired conditions (30-40% RH is recommended). Operation of this unit is automatic.

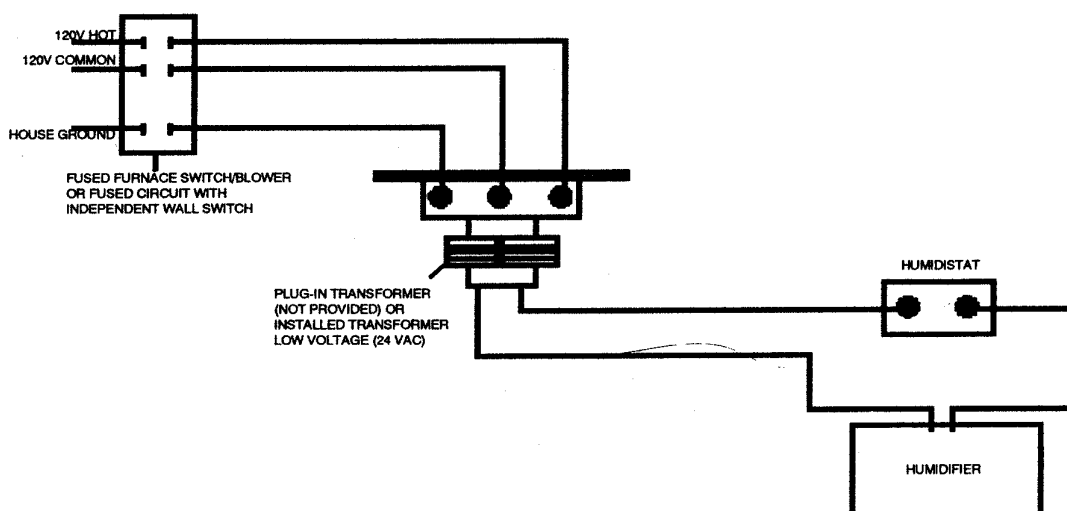

Figure 5 - ELECTRICAL CONNECTIONS

Humidifier Capacity Selection Guide

Sq. Footage of Home	Tight House	Average House	Loose House
1000	0.5 GPD	5.0 GPD	10.0 GPD
1500	3.0 GPD	10.0 GPD	16.5 GPD
2000	5.0 GPD	14.0 GPD	24.0 GPD
2500	7.5 GPD	19.0 GPD	30.5 GPD
3000	10.0 GPD	23.5 GPD	37.5 GPD
4000	14.5 GPD	33.0 GPD	51.5 GPD

For reference only - calculations based on:

- Indoor temperature of 70° F and 35% Relative Humidity
- Outside temperature of 20° F and 70% Relative Humidity
- 8' Ceiling height
- Internal moisture gain of 1 lb. Per hour
- Furnace on-time of 70%

This chart uses A.R.I. standard designations:

- A Tight House is assumed to be well insulated with vapor barriers, tight storm doors and windows and a dampered fireplace. Air change rate of .50 changes per hour.
- An Average House is insulated and has a dampered fireplace, but there are no vapor barriers and storm windows and doors are assumed loose. Air change rate of 1.0 change per hour.
- A Loose House is generally one constructed before 1930, having little or no insulation, no storm doors or windows, no weather stripping or vapor barriers and often, no effective dampering of fireplaces. Air change rate is as high as 1.5 per hour.

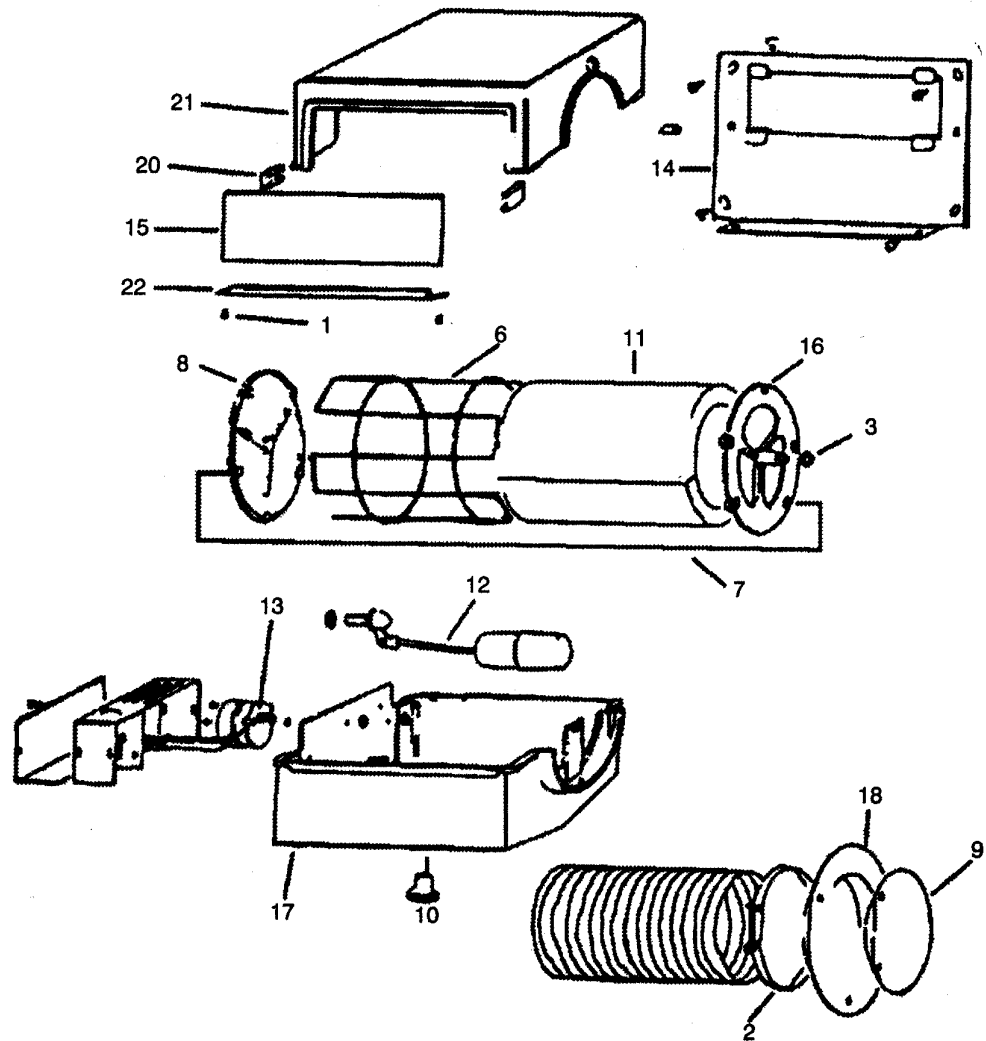

Ref. #	Description	447-C1
1	#6-20 x 3/8" Window Retainer Screw (2)	1028
2	Auto Clamp	1410
3	Bearing	1223
4	Cable Clamp (Not Shown)	1307
5	Cable Clamp Screw (Not Shown)	1306
6	Cage	1413
7	Cage & Pad Assembly	1425
8	Closed End	1402
9	Damper	1247
10	Drain Plug	2408B
11	Evaporator Pad	1412
12	Float & Valve Assembly	1405A
13	Motor 24V (replaces 1414A)	1322
14	Mounting Plate	1415
15	Observation Window	1407
16	Open End	1403
17	Pan & Tube Assembly	1400
18	Return Air Flange	1409
19	Safety Clip (2)	1020
20	Slide Clip (2)	1408A
21	Top	1401
22	Window Retainer	1406

N/A =Not Applicable * =Obsolete Unit

ELECTRONIC AIR CLEANER AND HUMIDIFIER

LIMITED TWO-YEAR WARRANTY

This limited warranty covers Trion Residential Type Electronic Air Cleaners and Humidifiers, excluding duct work, wiring and installation.

Trion, Inc. warrants that all new Trion Residential Type Electronic Air Cleaners and Humidifiers are free from defects in material and workmanship under normal, noncommercial use and service. Trion will remedy any such defects if they appear within 24 months from the date of original installation as evidenced by receipt of the warranty registration card, subject to the terms and conditions of this Limited Two-Year Warranty stated below:

1. THIS LIMITED TWO-YEAR WARRANTY IS GRANTED BY TRION INC., McNEILL ROAD, P.O. BOX 760, SANFORD, NORTH CAROLINA 27330.
2. This warranty shall extend only to any noncommercial owner who has purchased the residential electronic air cleaner or humidifier other than for purposes of resale.
3. The completion and return of the Warranty Registration Card is a condition precedent to warranty coverage and performance.
4. All components are covered by this limited warranty except expendable items, such as charcoal filters, disposable dirt holding pads, media evaporative pads, media filter pads and nozzles.
5. If within the warranty period any Trion residential electronic air cleaner or humidifier unit or related component requires service it must be performed by a competent heating and/or air conditioning contractor (preferably the installing contractor). Trion, Inc. will not pay shipping charges, or labor charges to remove or replace such defective parts or components. If the part or component is found by inspection to contain such defective material and workmanship it will be either repaired or exchanged free of charge at Trion's option, and returned freight collect.
6. In order to obtain the benefits of this limited two-year warranty, the owner must notify the dealer or distributor in writing of any defect within 30 days of its discovery. If after reasonable time you have not received an adequate response from the dealer or distributor, notify in writing Trion, Inc., McNeill Road, P.O. Box 760, Sanford, North Carolina 27330. Console or portable models of the electronic air cleaner or humidifier may be returned intact freight prepaid, but electronic air cleaners or humidifiers which have been installed or become part of real estate cannot be returned. Trion will receive, freight prepaid, only removable parts or components of such defective electronic air cleaners or humidifiers.
7. This limited warranty does not apply to any part or component that is: damaged in transit or when handling, has been subject to misuse, neglect or accident; has not been installed, operated and serviced according to Trion's instruction; has been operated beyond the factory rated capacity; or altered in any such way that its performance is affected. There is no warranty due to neglect, alteration or ordinary wear and tear. Trion's liability is limited to replacement of defective parts or components and does not include the payment of the cost of labor charges to remove or replace such defective components or parts.
8. Trion will not be responsible for loss of use of any product; loss of time, inconvenience, or any other indirect, incidental or consequential damages with respect to person or property, whether as a result of breach of warranty, neglect or otherwise. **SOME STATES DO NOT ALLOW THE EXCLUSION OR LIMITATION OF INCIDENTAL OR CONSEQUENTIAL DAMAGES, SO THE LIMITATION OR EXCLUSION IN THE PRECEDING SENTENCE MAY NOT APPLY TO YOU.**
9. **THIS WARRANTY GIVES YOU SPECIFIC RIGHTS, AND YOU MAY ALSO HAVE OTHER RIGHTS WHICH VARY FROM STATE TO STATE.**
10. Any warranty work will be performed within a reasonable time, usually within 120 days after notice of defect and delivery to the Trion factory, subject to delays beyond Trion's control.
11. Any warranty by Trion of merchantability, fitness for use or any other warranty (express, implied or statutory), representation or guarantee other than those set forth herein, shall expire at the expiration date of this express limited warranty. **SOME STATES DO NOT ALLOW LIMITATIONS ON HOW LONG AN IMPLIED WARRANTY LASTS, SO THE LIMITATION IN THE PRECEDING SENTENCE MAY NOT APPLY TO YOU.**
12. Trion reserves the right to make changes in the design and material of its products without incurring any obligation to incorporate such changes in units completed on the effective date of such change.

TRION INC.

101 McNeill Road • P.O. Box 760 • Sanford, NC 27331-0760 • Fax: 919-777-6355
PartNo. 252908-001 • © 1998 Trion Inc. • 10/98