

This Owner's Manual is provided and hosted by [Appliance Factory Parts](#).



HOLMES HAWF2095 Owner's Manual

[Shop genuine replacement parts for HOLMES
HAWF2095](#)

Holmēs

[Find Your HOLMES HVAC Parts - Select From 7 Models](#)

----- Manual continues below -----

TWIN WINDOW FAN

WITH ACCUTEMP™ DIGITAL CONTROL



Owner's Guide

◀ INFO HOT-LINE: If, after reading this owner's guide you have any questions or comments, please call 1-800-5-HOLMES and a Customer Service Representative will be happy to assist you.

PLEASE READ AND SAVE THESE INSTRUCTIONS

IMPORTANT INSTRUCTIONS

When using electrical appliances, basic safety precautions should always be taken including the following:

- Use fan only for purposes described in the instruction manual.
- To protect against electrical shock do not immerse unit, plug or cord in water or spray with liquids.
- Close supervision is necessary when any appliance is used by or near children.
- Unplug from outlet when not in use, when moving fan from one location to another, before putting on or taking off parts, and before cleaning.
- Avoid contact with moving parts.
- Do not operate in the presence of explosive and/or flammable fumes.
- Do not place fan or any parts near an open flame, cooking or other heating appliance.
- Do not operate any appliance with a damaged cord, plug, after the appliance malfunctions, or has been dropped/ damaged in any manner.
- The use of attachments not recommended or sold by the appliance manufacturer may cause hazards.
- Do not use outdoors.

- Do not let the cord hang over the edge of a table, counter, or come in contact with hot surfaces.
- To disconnect, grip plug and pull from wall outlet. Never yank on cord.
- Always use on a dry, level surface.
- Do not operate without fan grills properly in place.
- This product is intended for household use ONLY and not for commercial or industrial applications.

PLEASE READ AND SAVE THESE INSTRUCTIONS

WARNING: To reduce the risk of fire or electrical shock, DO NOT USE THIS FAN with any SOLID STATE Fan Speed Control Device

THIS PRODUCT IS EQUIPPED WITH A POLARIZED A.C. (Alternating Current) PLUG (a plug having one blade wider than the other). This plug will fit into the power outlet only one way. This is a safety feature. If you are unable to insert the plug fully into the outlet, try reversing the plug. If the plug should still fail to fit, contact an electrician to replace the obsolete outlet.
DO NOT DEFEAT THE SAFETY PURPOSE OF THIS POLARIZED PLUG



PRE-INSTALLATION INSTRUCTIONS:

Carefully unpack all contents of carton.

- The window fan comes fully assembled and is ready for immediate installation.
- Before installation, familiarize yourself with the built-in 7" extender on the right side of the fan, and the two additional 3." extenders which attach to the left side of the fan housing (see figure #1.) The extra extenders are packed in styrofoam at each end of the box.

WE RECOMMENDED KEEPING YOUR WINDOW SCREEN IN PLACE

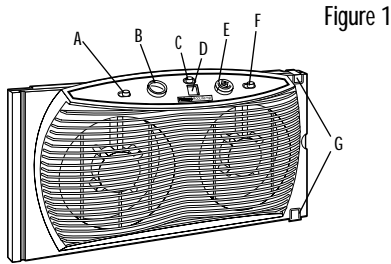

- Figure 1
- A. Left Fan Intake-Exhaust/Air Exchange
 - B. Fan Speed Control
 - C. Manual/Automatic Setting
 - D. LCD Display
 - E. Temp. Set
 - F. Right Fan Intake-Exhaust/Air Exchange
 - G. Extender Locks

INSTALLATION INSTRUCTIONS:

This window fan has been designed to fit double-hung, slider and casement windows with minimum openings of 24." wide and 13" high. For casement windows, please see page 3 for information on available bracket. This fan is designed and recommended for used with your window screen in place.

For double-hung and slider windows:

NOTE: On SLIDER WINDOWS the bottom section must be the side you add extenders to (left side). The controls should be facing toward the window.

1. With the window open, take an accurate measurement of the opening where the unit will be placed.
2. Match your window measurement with the installation guide (see figure #2 text); adding the appropriate extender panel(s) to the left side, while using the built-in extender on the right side.
3. Once you have added extender panel(s) if necessary, set the fan in the window, and complete the installation process using the built-in extender. Pull out for a snug, safe fit (see step 5)
4. Carefully close the window onto the top of the fan so that the bottom edge of the window rests behind top line of fan housing. This is important as it aides in keeping the fan in place.
5. Lastly, pull out the built-in extender on right side to fill in the remaining space. To pull out, simply pop up the extender locks on the top and bottom of the fan housing next to the built-in extender, and set to the desired length. To secure in place, push the extender locks back down.

Casement Windows:

For a safe, secure fit in your casement window, you will need a special bracket system. For easier installation in a casement window, we provide you with two brackets and screws at no additional cost. Please keep in mind, your window must be at least 24" high and 13" wide to use this window fan/bracket combination. Please call our customer service department, 1-800-5-HOLMES, for further assistance.

INSTALLATION GUIDE:

For 24" to 27": Use up to 3" of right side, pull out extender.

For 28" to 34": Use one 3" extender panel on the left side. Adjust the pull out extender on the right side for a tight fit (from .5" to 7").

For 35" to 37": Use two 3" extender panels on the left side. Adjust the pull out extender on the right for a tight fit (to 5" to 7").

Larger than 37": Additional extender panels will be required.

To order additional extenders, see mail order offer or call 1-800-5-HOLMES

FIGURE 2

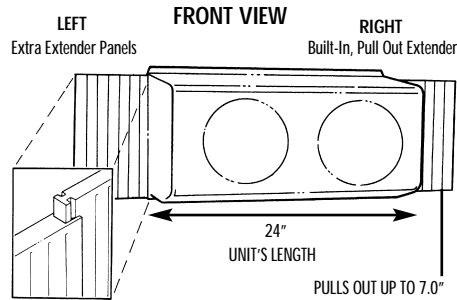

Two 3.0" extenders, (Included in your box packed at both ends)

OPERATING INSTRUCTIONS:

- Make sure the rotary switch is in the OFF position.
- Plug into 120V AC electric outlet.
- Set the individual fan motors on either INTAKE, EXHAUST or AIR EXCHANGE using the control lever.
- To start unit, select either **Manual** or **Automatic**.

In **Manual** mode turn the rotary switch to the desired speed (HI, MED, LO) for standard operation.

In **Automatic** mode, you must set desired temperature using the following Accutemp™ instructions.

ACCUTEMP™ DIGITAL CONTROL INSTRUCTIONS:

Your window fan is equipped with an Accutemp™ Digital Control that automatically varies the fan speed and turns the fan ON and OFF depending on the preset comfort level. This is ideal for operation at night when the temperature drops.

1. Make sure the manual/automatic switch above display is set to automatic.
2. Turn speed control to HI, MED, or LO
3. Press down on the temp set buttons to program the desired temperature. To set and hold higher temperatures, press the top button, for lower temperatures, press the bottom button. Hold the button down until you see your desired temperature displayed.
4. When you are finished setting the temperature, let go of the button. The display will blink a few times and then return to displaying the current room temperature.
5. If the unit will not start in Automatic mode, please make sure that the "set temperature" is below the current room temperature. If the fan is stopped and you want to turn it back on, lower the temperature setting until you have reached the desired temperature.

IMPORTANT: If you desire continuous running of the fan, turn the manual/automatic level to manual and adjust the hi/med/low speed button.

WARNING: BE SURE FAN IS SECURELY INSTALLED IN YOUR WINDOW AT ALL TIMES. DO NOT LEAN OR PUSH ON FAN WHILE IT IS IN THE WINDOW.

CLEANING/MAINTENANCE INSTRUCTIONS:

Follow these instructions to correctly and safely care for your Holmes window fan.

Please remember:

- Always unplug the fan before cleaning or disassembling.
- Do not allow water to drip on or enter into the fan housing.
- Be sure to use a soft cloth moistened with mild soap solution.
- Do not use any of the following as a cleaner: gasoline, thinner, or benzine.

Fan Blade and Front Grill Cleaning:

To clean fan blade and front grill

1. Using a phillips head screwdriver, remove the screws that hold the front and rear grills together.
2. Clean blades and grills with a soft, moist cloth (see above).
3. Securely fasten the grills together.

OPTIONAL POLLEN CATCHER INSTRUCTIONS:

The HAWF-2095 can be used with a specially designed air filter. The new "Pollen Catcher" System will trap small dirt, dust, pollen and other small particles. Pollen Catcher filters are made of a washable foam material that can be re-used; with a recommended replacement interval of 2-3 months.

A special limited offer is available on the purchase of additional Pollen Catcher Filters. For \$12.99 including shipping and handling, we will ship you two additional filters. To reorder call 1-800-5-HOLMES.

Page 3

FAN SERVICE INSTRUCTIONS:

1. Do NOT attempt to repair or adjust any electrical or mechanical functions on this unit. Doing so will void the warranty.
2. If you have any questions regarding this unit's operation or believe any repair is necessary, please call 1-800-5-HOLMES to speak with a Customer Service Representative.
3. If you need to exchange the unit, please return it in its original carton, with a sales receipt, to the store where you purchased it. If you are returning the unit more than 30 days after the date of purchase, please see the enclosed warranty.
4. If you have any other questions or comments, feel free to write us:

Holmes Products

P.O. Box 769

Milford, MA 01757-0769

DETACH FROM INSTRUCTIONS AND MAIL IN THIS FORM

IT'S A GREAT IDEA! Additional Extender Panels & Pollen Catcher™ Filters Available

EXTENDER PANELS
\$9.99 (per pair)

**POLLEN
CATCHER™ FILTERS**
\$12.99/per pair

INCLUDES SHIPPING
AND HANDLING

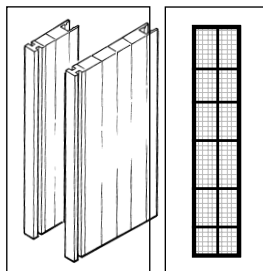

Fill out form on reverse side or call
1-800-5-HOLMES
to place your order today.

For your own records, staple or attach your sales receipt to this manual. Also, please take a moment to write the store name/location and date purchased below.

STORE NAME _____
 LOCATION: _____
 DATE PURCHASED: _____

(STAPLE RECEIPT HERE)

DETACH FROM INSTRUCTIONS AND MAIL IN THIS FORM

PLEASE USE THIS FORM TO ORDER-BY-MAIL.
 A photocopy of this form will not be accepted

| ITEM # | DESCRIPTION | QUANTITY | PRICE | SUB TOTAL |
|--|-------------------------------|----------|-----------------|-----------|
| EP2095 | Extender Panels for HAWF 2095 | | \$9.99/ pair | |
| PC2095 | Pollen Catcher for HAWF 2095 | | \$12.99 | |
| Mass residents add appropriate sales tax | | | | |
| TOTAL | | | | |

Method of Payment: Check/Money Order MC Visa
 Account # _____
 Exp. Date _____
 Signature _____

SHIP TO: (PLEASE PRINT) _____ PHONE # _____

STREET _____

CITY _____ STATE _____ ZIP _____

To order, please send your (U.S. Bank) check or money order, and this completed form to: **HOLMES PRODUCTS CORP., P.O. Box 769, Milford, MA 01757-0769**

Three (3) Year Limited Warranty

SAVE THIS WARRANTY INFORMATION

- A. The quality controls used in the manufacture of this Holmes product are to ensure your satisfaction.
- B. This Warranty applies ONLY to repair or replacement of any supplied or manufactured parts of this product that, upon inspection by Holmes authorized personnel, proves to have failed in normal use due to defects in material or workmanship. Holmes will determine whether to repair or replace the unit. This Warranty does not apply to installation expenses.
- C. Operating this unit under conditions other than those recommended or at voltages other than the voltage indicated on the unit, or attempting to service or modify the unit, will render this WARRANTY VOID.
- D. Unless otherwise proscribed by law, Holmes shall not be liable for any personal injury, property or any incidental or consequential damages of any kind (including water damage) resulting from malfunctions, defects, misuse, improper installation or alteration of this product.
- E. All parts of this Holmes product (expect for filters and removable parts not found to have factory defects) are guaranteed for a period of 3 years as follows:
 1. Within the first 30 days from date of purchase, the store from which you purchased your Holmes product should replace this product if it is defective in material or workmanship (provided the store has in-stock replacement.)
 2. Within the first thirty six months from date of purchase, subject to the conditions in paragraph G, Holmes will repair or replace the product if it is defective in material or workmanship providing it is returned to Holmes, freight prepaid, with PROOF OF PURCHASE date, together with \$10.00 for handling and return packing/shipping charges.
- F. If you have any problem with this product, please write our Customer Service Dept., or call, 1-800-5-HOLMES.
- G. IMPORTANT RETURN INSTRUCTIONS Your warranty depends on your following these instructions if you are returning the unit more than 30 days after the date of purchase:
 1. Carefully pack the item in its original carton or other suitable box to avoid damage in shipping.
 2. Before packing your unit for return; be sure to enclose:
 - a) your name, full address with zip code and telephone number,
 - b) a dated sales receipt or PROOF OF PURCHASE,
 - c) your \$10.00 check for return shipping and handling charges, and
 - d) the model number of the unit and the problem you are having. (Enclose in an envelope and tape directly to the unit before the box is sealed.)
 3. Holmes recommends you ship the package U.P.S. ground service for tracking purposes.
 4. All shipping charges must be prepaid by you (as noted in paragraph G).
 5. Ship to:

HOLMES PRODUCTS CORP.,
 CUSTOMER SERVICE DEPARTMENT,
 233 FORTUNE BLVD.,
 MILFORD MA 01757

SHIPPING AND HANDLING CHARGES: \$10.00

This warranty gives you specific legal rights, and you may have other rights which vary from state to state. The provisions of this warranty are in addition to, and not a modification of, or subtraction from, the statutory warranties and other rights and remedies contained in any applicable legislation. To the extent that any provision of this warranty is inconsistent with any applicable law, such provision shall be deemed voided or amended, as necessary, to comply with such law.

HAWF-2095-95-U-MN-01

Printed in China
 Page 4