

Page 1

[Page 2](#)

[Page 3](#)

[Page 4](#)

HM-2200



Holmes

PureMist™ Humidifier

with Brita® Water Filter

Owner's Guide

- ☛ **INFO HOT-LINE:** If, after reading this owner's guide you have any questions or comments, please call 1-800-5-HOLMES and a Customer Service Representative will be happy to assist you.

PLEASE READ AND SAVE THESE IMPORTANT SAFEGUARDS

WHEN USING ELECTRICAL APPLIANCES BASIC SAFETY PRECAUTIONS SHOULD ALWAYS BE FOLLOWED TO REDUCE THE RISK OF FIRE, ELECTRIC SHOCK AND INJURY TO PERSONS, INCLUDING THE FOLLOWING:

1. NEVER drop or insert any object into any openings.
2. Place humidifier on a firm, flat, level surface. NEVER place it on a rug or carpet, or on a finished floor that may be damaged by exposure to water or moisture.
3. NEVER place humidifier in an area where it is accessible to children. NEVER use humidifier in a closed room, particularly where a child may be sleeping, resting or playing (a closed room may result in excessive humidity).
4. NEVER place humidifier near heat sources such as stoves, radiators, and heaters. Do locate your humidifier on an inside wall near an electrical outlet. The humidifier should be at least 4" away from the wall for best results.
5. NEVER connect humidifier to any power source other than a 120V AC outlet.
6. **WARNING: DO NOT ATTEMPT TO REFILL HUMIDIFIER WITHOUT FIRST UNPLUGGING THE UNIT FROM ITS ELECTRICAL OUTLET. FAILURE TO HEED THIS WARNING MAY CAUSE PERSONAL INJURY.**
7. DO NOT allow the moisture outlet to aim directly at a wall surface - this could cause damage, particularly to wall-paper.
8. Always unplug the humidifier when not in use.
9. NEVER tilt, move, or attempt to empty unit while it is operating. Shut off and unplug before removing the water tank and moving the unit.
10. This humidifier requires daily and weekly maintenance. Refer to CLEANING PROCEDURES.
11. Excessive humidity in a room can cause water condensation on windows and some furniture. If this happens, shut OFF the unit.
12. Never use detergents, gasoline, glass cleaner, furniture polish, paint thinner or household solvents on any part of the humidifier.
13. Do not use humidifier in area where humidity level is in excess of 50%. You can monitor your humidity level by using a hygrometer, an instrument which measures humidity levels. You can purchase a hygrometer in most hardware stores or directly through Holmes by calling 1-800-5 HOLMES. Place the meter at least 10 feet from the unit for best results. DO NOT allow the mist to come in direct contact with humidity meter.

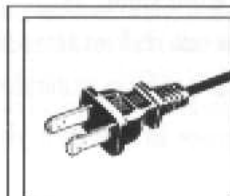

THIS PRODUCT IS EQUIPPED WITH A POLARIZED A.C. (Alternating Current) PLUG (a plug having one blade wider than the other). This plug will fit into the power outlet only one way. This is a safety feature. TO PREVENT ELECTRIC SHOCK, MATCH WIDE BLADE OF PLUG TO WIDE SLOT, FULLY INSERT. If you are unable to insert the plug fully into the outlet, try reversing the plug. If the plug should still fail to fit, contact an electrician to replace the obsolete outlet. DO NOT DEFEAT THE PURPOSE OF THIS POLARIZED PLUG.

[Page 1](#)

Page 2

[Page 3](#)

[Page 4](#)

PRE-OPERATING INSTRUCTIONS:

1. Remove the humidifier from the packaging and set it on the floor or table top where it will be operating. Be sure the unit is disconnected from the electrical outlet and the power switch is in the OFF position.
2. Lift off the humidifier housing and the water tank (see Fig. 1).
3. During shipping, the Brita Filter is packed inside the main humidifier housing. YOU MUST REMOVE THE BRITA® FILTER FROM INSIDE THE HUMIDIFIER HOUSING.
4. On first time use, remove the circular, Wicking Filter from the reservoir and wet it by running cool, clean tap water over the filter surface until the wick filter is fully wet. Replace the filter. Make sure it is installed correctly around the filter supports in the base (see Fig. 2). Replace the humidifier housing.

INSTALL THE BRITA WATER FILTER:

Remove the Brita Water Filter from its protective pouch. On first use, soak the filter in cold water for 15 minutes. Hold the filter upright under cold running tap water for a few second to flush through. Insert the filter in the Brita Filter Holder (see Fig. 2). Press down firmly to ensure a tight seal. **Note: It is normal for a few specs of carbon dust appear in the tank. It is normal that the filter is packed wet.**

FILLING THE TANK:

4. Twist off the tank cap by turning counter-clockwise and fill the water tank with cool, tap water. Replace the tank cap by firmly turning clockwise and then replace the water tank on the base.

It is normal for the humidifier to take about 15 minutes to reach maximum output when the tank is refilled while the water runs through the humidifier. Initially, it may take 5-10 minutes to fill the main water reservoir. **NOTE: the HM-2200 produces a clean, cool, INVISIBLE moisture. It is normal not to see the moisture.**

5. Plug the power cord into the electrical outlet.
6. Move the Humidity Control Switch to the HI position, and adjust the Humidity Control Switch to Med or Lo speed depending on your needs. We recommend the use of a Comfort Check hygrometer which reads the actual temperature and humidity level in your room. A humidity level below 20% can be unhealthy and uncomfortable. The recommended humidity level is between 40% and 50%. Comfort Check hygrometers are available through Holmes by calling 1-800-5 HOLMES.

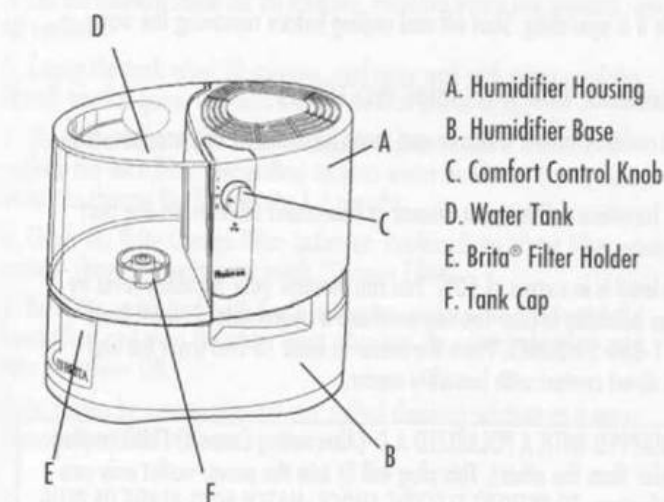

fig. 1

OPERATING INSTRUCTIONS:

The water from the tank will flow through the Brita Filter. The filtered water will collect inside the Filter Holder and travel across the Water Channel (see fig 1) to the Main Water Reservoir. The filtered water will remain in the Main Water Reservoir until it is used. This process will constantly repeat itself until the tank runs out of water. Please note that this humidifier may be operated without the Brita Water Filter in place, but you will not receive the benefit of the Brita water filtration.

TOUBLESHOOTING

IF WATER FLOW SLOWS OR STOPS

1. Remove Brita® filter
2. Rinse Brita® filter briefly under cool water
3. Shake Brita® filter dry

NOTE: If product will not be used for more than two days, be sure to drain any residual water. **Questions? Call 1-800-5-HOLMES**

REFILLING THE TANK:

1. When the water tank is completely empty, you need to refill the tank. The fan will continue to run to help dry the humidifier. Shut off and unplug the unit. Follow the Daily Cleaning Instructions.
2. Check to see if the circular Extended Life Filter needs replacing by comparing the Color-coded Filter Change Indicator (located on the side of the humidifier housing) with the filter wear.
3. Refill the tank as directed in Pre-Operating Instructions. Each time you refill the tank, you should turn the Brita Filter Change Dial (see fig 2) one click. When the tank has been refilled 35 times, the dial will read "Change Filter". It is recommended that the Brita Filter is changed every 35 gallons or two months, whichever comes first.
4. Plug into the electrical outlet. Turn the Humidity Control Dial to HI.

IMPORTANT: If you do not plan to use your humidifier for two or more days, make sure ALL residual water is drained from the water tank, base and both the Brita and Wick Filters areas to prevent any algae or bacteria growth in stagnant water.

Holmes filters are pre-treated with an algicide coating for prolonged life.

REPLACEMENT OF FILTERS:

This humidifier features two filters, the Brita Water Filter and the circular Extended Life wick filter. Filter replacement is essential for the product to perform as represented.

Changing the Brita Water Filter:

To maintain maximum efficiency, it is recommended that the Brita Water Filter is changed every 35 gallons or two months. You can monitor the number of gallons used by checking the Brita Filter Change Dial located on the inside of the humidifier. The dial counts the number of tanks placed onto the base. When the number of tanks reaches 35, the dial will read "Change Filter".

To replace the Brita Filter:

1. Lift off the water tank. Pull out Brita Filter.
2. Follow Brita Filter installation instructions in Pre-Operating Instructions.

[Page 1](#)

[Page 2](#)

Page 3

[Page 4](#)

Changing the circular Extended Life Wick Filter:

Through normal use, water-borne minerals and sediment become trapped in the wick filter. The use of the Brita Water Filter will significantly reduce sediment, soften the water, and reduce scale build-up. When to replace your wick filter will vary greatly depending on water hardness, the proper maintenance of your humidifier and the timely replacement of the Brita filter.

You will be able to monitor the life of the filter in your humidifier by checking the Color-coded Filter Change Indicator (located on the side of the housing) which shows the color the filter should be at the time of replacement. In general, when the wick filter turns brown over most of the surface, it is time to replace the filter.

To replace the wick filter:

1. Switch the humidifier OFF and unplug. Remove the tank and the housing, lift out the used wick filter, and throw it away.
2. Remove the protective bag from the new Wick Filter and slide the filter down around the filter support circle in the base. Replace the housing, refill and replace the tank, plug the cord into the electrical outlet and switch ON. It will take about 30 minutes for the humidifier to reach the normal moisture output.
1. Switch the humidifier OFF and unplug. Remove the tank and the housing, lift out the used wick filter, and throw it away.
2. Remove the protective bag from the new Wick Filter and slide the filter down around the filter support circle in the base. Replace the housing, refill and replace the tank, plug the cord into the electrical outlet and switch ON. It will take about 30 minutes for the humidifier to reach the normal moisture output.

Replacement Brita Filters and Wick Filters (model HWF-64) are available at your local retailer or by calling 1-800-5-HOLMES. This humidifier uses

maintenance guidelines. Please note this is an electrical appliance and requires attention when in use.

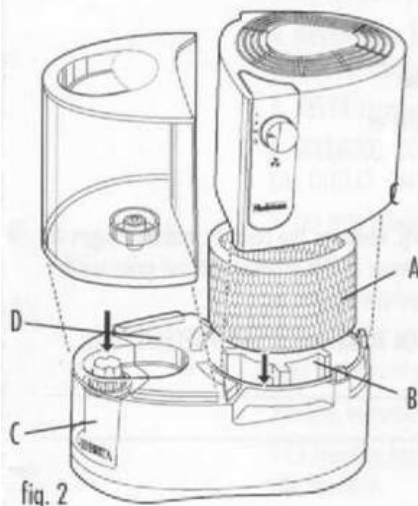

- A. Wick Filter
- B. Wick Filter Holder
- C. Brita® Filter
- D. Brita® Filter Change Dial (not shown)

Brita Water Filter System Filters which are also available at your local retailer. It is recommended that you order your replacement filters at once so you will have a fresh filter available when necessary.

CLEANING PROCEDURES:

Humidifiers provide comfort by adding moisture to dry, heated indoor air. Evaporative Wick humidifiers are designed to add moisture to the air in the form of water vapor, via fan forced air traveling through a moistened medium. To get the most benefit from the humidifier and avoid product misuse, follow all instructions carefully, specifically the operation, care and

[Page 1](#)

[Page 2](#)

[Page 3](#)

Page 4

If you do not follow the recommended care and maintenance guidelines, micro-organisms may be able to grow in the water within the humidifier's reservoir.

The following cleaning procedures must be routinely followed in order to ensure proper, efficient operation of your humidifier. Proper maintenance is essential to the continued use of your unit and the avoidance of algae or bacteria build-up.

DAILY MAINTENANCE (each time tank is refilled)

1. Before cleaning, set control to the OFF position and unplug the unit from the electrical outlet.
2. Lift off the tank and the housing of the humidifier.
3. Carry the base and the tank to the sink, remove the wick filter, then drain and rinse the base and tank thoroughly to remove any sediment or dirt. Wipe clean, and dry with a clean cloth or paper towel.
4. Put the filter back correctly around the Wick Filter supports, replace the housing, then refill the tank with with cool tap water as instructed in Pre-Operating Instructions. Do not overfill.
5. Lower humidity control settings or turn off humidifier if moisture forms on walls or windows.

WEEKLY MAINTENANCE

To Remove Scale, Disinfect Reservoir and Tank

1. Repeat steps 1-3 above and remove both the circular Wick Filter and the Brita Water Filter.
2. Clean the reservoir by partially filling the base with Holmes Cleanse Clean™ (available through Holmes) S-1710 as instructed on bottle, or with one 8 oz. cup of undiluted white vinegar. Let solution stand 20 minutes, cleaning all interior surfaces with a soft brush. Dampen a cloth with Cleanse Clean™ or undiluted white vinegar and wipe out entire base to remove scale.
3. Disinfect the reservoir by filling reservoir with 1 teaspoon of chlorine bleach and one 8 oz. cup of water. Let solution stand for 20 minutes, cleaning all interior surfaces with a cloth or soft brush. Wipe out and rinse entire base.

Disinfect Tank

4. Fill tank with 1 teaspoon of chlorine bleach and 1 gallon of water.
5. Let the solution stand for 20 minutes, swishing every few minutes, wet all surfaces.
6. Empty the tank after 20 minutes, and rinse well with water until the bleach smell is gone. Dry with a clean cloth or paper towel.
7. Check the Color-coded Filter Change Indicator to see if it is time to replace the wick filter. Depending on your water hardness, it may be necessary to change the filter every 1-2 months.
8. Check the Brita Change Filter indicator. Replace Brita Water Filter when counter shows 35 gallons, or reads "Change Filter".
9. Refill the water tank with fresh tap water, replace the housing of the humidifier, and then the water tank. Plug into the electrical outlet, and turn the power ON.

Note: Please be sure to wipe up any spilled cleaning solution as it may damage furniture or floors.

END OF SEASON MAINTENANCE:

1. Follow weekly maintenance instructions at end of season or when humidifier will not be used for at least one week or more.
2. Remove and throw away filters.
3. Let humidifier dry completely before storing. Do not store with water inside reservoir.
4. Store in a cool, dry location.
5. Install new filters and clean humidifier before next season begins.

SERVICE INSTRUCTIONS:

1. DO NOT attempt to repair or adjust any electrical or mechanical functions on this unit. Doing so will void your warranty.
2. If you have any questions on operation or believe any form of repair is necessary, please call 1-800-5-HOLMES to speak with a Customer Service Representative.
3. If you need to exchange this product within the first 30 days, please return the unit in it's original carton, with a sales receipt to the store from where you purchased it. After 30 days please review your warranty information.
4. If you have any questions or comments, or would like to order replacement accessories, please write or call us at: Holmes Products Corp.
P.O. Box 769
Milford, MA 01757-0769
Tel: 1-800-5-HOLMES

Replacement Accessories (see included Humidifier Accessory Form)

- Comfort Check hygrometer/thermometer
Digital HHG-175
Analog HHG-150
- Brita® Replacement Water Filter
- HWF-64 Replacement Wick Filter or
HWF-80 Season Pack
- S-1710 Cleanse Clean™

Please note: Holmes Products Corp. reserves the right to make changes or alterations, or to modify specifications in this product without prior notification.

FOR YOUR OWN RECORDS, ATTACH YOUR DATED SALES RECEIPT HERE:

DATE PURCHASED: _____

Store/Location: _____