

HEALTH *at* HOME

Sunbeam

ULTRASONIC HUMIDIFIER

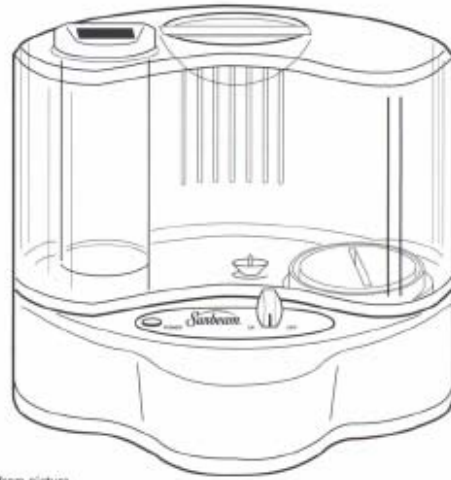

Model 696
Product may vary from picture.

Read And Save These Instructions

Important notes

Please read this manual carefully before using this device.
This Humidifier is intended for use by adults. For household use only.

BREATHING at HOME

Sunbeam®

A comfortable choice

Sunbeam's Ultrasonic Humidifier. For a moister, more comfortable environment, use your Ultrasonic Humidifier. Product can be very beneficial to your breathing and to the suppleness of your skin.

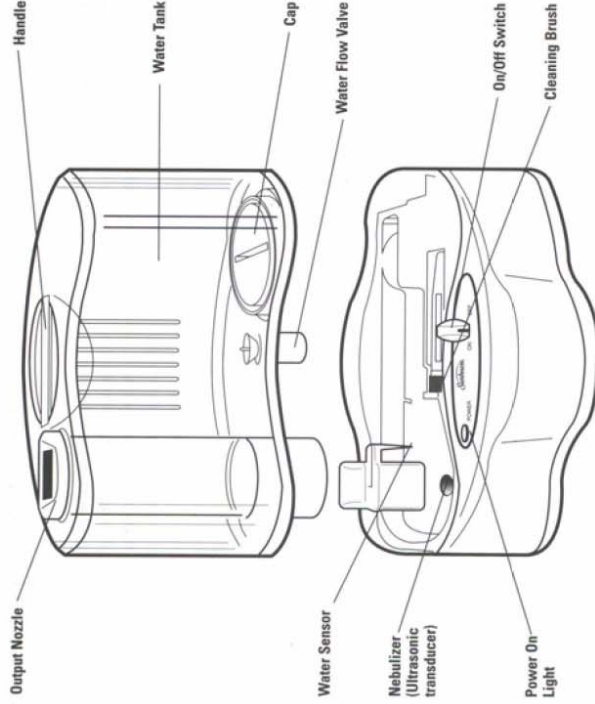

Features of the Ultrasonic Humidifier

- 1) Base
 - Water sensor
 - Nebulizer — Ultrasonic transducer
 - Cleaning brush
 - Power on light
 - On/Off switch
- 2) Water tank
 - Water flow valve
 - Cap
 - Output Nozzle
 - Handle

Read all instructions: Important Safeguards

When using electrical appliances, especially when children are present, basic safety precautions should always be followed, including the following:

1. Always have water in the water tank when operating unit.
2. Use only clean, cool, tap water to fill tank (softened or distilled water is recommended, if tap water is hard).
3. To avoid white dust, you may use distilled water, or a demineralization cartridge.
4. Be sure the filling cap of the tank is firmly tightened.
5. Always have the mist nozzle and the mist chamber in place while the unit is operating. Rotate the mist nozzle so it is aimed away from children, walls and furniture.
6. Use only 110-120v AC outlet. As with any electrical device, plug and unplug unit with dry hands only. Turn unit off to unplug.
7. Never operate unit with a damaged cord or plug.
8. Always place unit on a flat, level surface away from direct sunlight. Keep cord away from heated surfaces and areas where it could be walked on or tripped over. Note: The mist will automatically shut off when the tank is empty; however the fan will continue to run.
9. Unplug the unit when not in use and whenever you clean or move the unit.
10. Do not add medication of any type into the nozzle, base or water tank. Do not cover any opening of the unit or insert objects into any openings.
11. The unit should not be left unattended in closed rooms as air could become saturated and leave condensation on walls or furniture. Always leave room door partly open.
12. When cleaning inside of unit, keep water away from the air outlet. Exterior may be wiped with a damp cloth (except for electrical controls) when unit is off. Any part may be wiped with a damp cloth when unit is unplugged.
13. Do not tilt or tip unit or attempt to empty or fill it while it is operating.
14. Do not use detergent to clean any water containing parts of the unit. Detergent film dissolved in the water supply can interfere with the output of the unit.
15. The nebulizer (ultrasonic transducer) is highly sensitive. Keep this important part clean and treat it gently. Do not touch the nebulizer while the unit is operating, as possible burns could result. Do not touch the nebulizer with bare fingers. Any residue on the metal will reduce mist output.

How to use your ultrasonic humidifier

- 1) Place unit on level surface.
- 2) Fill Water Tank.
 - a. Remove tank from base.
 - b. Turn upside down and unscrew filling cap.
 - c. Fill tank with clean, cool, distilled or tap water.
 - Distilled or softened water is highly preferred. Mineral in tap (hard) water may cause a white dust to appear on your furniture, etc.
 - Extreme temperatures can damage unit. Water temperature should NEVER be too hot or too cold.
 - d. Return tank to base and let sit for a few minutes.
- 3) Turn Unit On.
 - a. Plug power cord into a 120V AC wall outlet only.
 - b. Turn power switch to "on" position. Power light will illuminate.
 - c. Turn mist nozzle until the desired level is being released.
 - Aim nozzle away from furniture and walls.
- 4) Turn Off Unit When Finished.
 - Always turn off when water runs out. Unit will continue to operate when tank is empty.
 - Do not let water sit in tank for long. This can encourage bacterial growth.

Caring for your Ultrasonic Humidifier

When to Clean

- Every third day during heating season
- Before storing
- After long periods of storage

Sanitizing Water Tank

- Use a mild bleach and water solution.
- Never use detergent.

Cleaning Nebulizer and Water Sensor

- 1) Remove tank from base and empty reservoir.
- 2) Take brush stored in base and clean off mineral deposits and debris from nebulizer and water sensor.
 - Do not scrape or clean with tools that have metal parts.

Storing Unit

- Make sure all parts are thoroughly dry.
- Leave filling door of tank loosened to keep door and gasket from sticking together.

Finding the Ideal Humidity Level for Your Home

- Aim for 30 to 50% relative humidity.
 - Humidity will vary room to room. Adjust accordingly.
 - If windows and walls fog or frost, reduce mist intensity.
 - If room is too humid, ventilate by opening door or window, and adjust mist intensity. High level humidity can allow moisture to collect and harm furniture, walls, especially wallpaper. It can encourage bacterial and fungal growth.
-

1 Year Limited Warranty

Do not return this product to the place of purchase.

If you have any questions regarding this warranty please call 1-800-435-1250 or write to: Sunbeam Products, Inc. 95 W. L. Runnels Industrial Drive, Dock M-5, Hattiesburg, MS 39401.

Sunbeam Products, Inc. ("Sunbeam") warrants that for a period of one year from the date of purchase, this product will be free from defects in material and workmanship. Sunbeam, at its option, will repair or replace this product or any component of the product found to be defective during the warranty period. Replacement will be made with a new or remanufactured product or component. If the product is no longer available, replacement may be made with a similar product of equal or greater value. This is your exclusive warranty. This warranty is valid for the original retail purchaser from the date of initial retail purchase and is not transferable. Keep the original sales receipt. Proof of purchase is required to obtain warranty performance. Sunbeam dealers, service centers, or retail stores selling Sunbeam Products do not have the right to alter, modify or any way change the terms and conditions of this warranty.

This warranty does not cover normal wear of parts or damage resulting from any of the following negligent use or misuse of the product, use on improper voltage or current, use contrary to the opening instructions, disassembly, repair or alteration by anyone other than Sunbeam or an authorized service center. Further, the warranty does not cover Acts of God, such as fire, flood, hurricanes and tornadoes.

Sunbeam shall not be liable for any incidental or consequential damages caused by the breach of any express or implied warranty. Except to the extent prohibited by applicable law, any implied warranty of merchantability or fitness for a particular purpose is limited in duration to the duration of the above warranty. Some states, provinces or jurisdictions do not allow the exclusion or limitation of incidental or consequential damages or limitations on how long an implied warranty lasts, so the above limitations or exclusion may not apply to you. This warranty gives you specific legal rights, and you may also have other rights that vary from state to state or province to province.

How to Obtain Warranty Service

Take the product to an authorized Sunbeam service center. You can find the nearest authorized Sunbeam service center by calling 1-800-435-1250. If a service center is not conveniently located, attach a tag to the product that includes your name, address, daytime phone number and description of the problem. Include a copy of the original sales receipt. Carefully package the product and send either by UPS or Parcel Post with shipping and insurance prepaid to:

For products purchased in the United States:

Sunbeam Products, Inc.
95 W. L. Runnels Industrial Drive
Dock M-5
Hattiesburg, MS 39401

For products purchased in Canada:

Sunbeam Appliance Service Station (KND)
100 Alfred Kuehne Boulevard
Brampton, ON L6T 4K4
1-800-667-8623