

Holmes®

Equipped with



Motor

INFO HOT-LINE: If, after reading this owner's guide you have any questions or comments, please call 1-800-5-HOLMES and a Consumer Service Representative will be happy to assist you.

Console Humidifier

HM3640

Owner's Guide

FILTER# HWF75
FILTER TYPE: WICK



PLEASE READ AND SAVE THESE IMPORTANT INSTRUCTIONS

PLEASE READ AND SAVE THESE IMPORTANT SAFETY INSTRUCTIONS

WHEN USING ELECTRICAL APPLIANCES, ESPECIALLY WHERE CHILDREN ARE PRESENT, YOU SHOULD ALWAYS FOLLOW THESE BASIC PRECAUTIONS TO REDUCE THE RISK OF FIRE, ELECTRIC SHOCK AND INJURY TO PERSONS:

1. Read all instructions before using the appliance.
2. To avoid fire or shock hazard, plug the appliance directly into a 120 V AC electrical outlet.
3. Keep the cord out of heavy traffic areas. To avoid fire hazard, NEVER put the cord under rugs, near heat registers, radiator, stoves, or heaters.
4. DO NOT place humidifier near heat sources such as stoves, radiators, and heaters. Do locate your humidifier on an inside wall near an electrical outlet. The humidifier should be at least 4" away from the wall for best results.
5. NEVER place humidifier in an area where it is accessible to children. NEVER use humidifier in a closed room, particularly where a child may be sleeping, resting, or playing (a closed room may result in excessive humidity).
6. **WARNING: DO NOT attempt to refill humidifier without first unplugging the unit from it's electrical outlet. Failure to heed this warning may cause personal injury. Be sure to pull the plug and not the cord.**
7. Never place anything over moisture outlet when the unit is running.
8. NEVER drop or insert any object into any openings.
9. DO NOT operate any appliance with a damaged cord or plug, after the appliance malfunctions, or if it has been dropped or damaged in any manner. Return appliance to manufacturer for examination, electrical or mechanical adjustment, or repair.
10. Use appliance only for intended household use as described in this manual. Any other use not recommended by the manufacturer may cause fire, electric shock, or injury to persons. The use of attachments not recommended or sold by The Holmes Group, Inc. may cause hazards.
11. DO NOT use outdoors.
12. Always place humidifier on a firm, flat, level surface. A waterproof mat or pad is recommended for under the humidifier. NEVER place it on a rug or carpet, or on a finished floor that may be damaged by exposure to water or moisture.
13. DO NOT allow the Moisture Outlet to directly face the wall. Moisture could cause damage, particularly to wallpaper.
14. Humidifier should be unplugged when not in use.
15. NEVER tilt, move, or attempt to empty unit while it is operating. Shut off and unplug before removing the water tank and moving the unit.
16. This humidifier requires daily and weekly maintenance to operate properly. Refer to the Cleaning and Maintenance instructions section in this manual.

17. NEVER use detergents, gasoline, glass cleaner, furniture polish, paint thinner, or other household solvents to clean any part of the humidifier. Use only Holmes® care products recommended in this manual.
18. DO NOT use humidifier in an area where humidity level is in excess of 50%; excessive moisture could cause damage. If the unit does not feature a hygrometer (a device use to measure the humidity level), one may be purchased by calling 1-800-5-HOLMES or visit www.holmesproducts.com.
19. DO NOT attempt to repair or adjust any electrical or mechanical functions on this unit. Doing so will void your warranty. The inside of the unit contains no user serviceable parts. All servicing should be performed by qualified personnel only.
20. Never place housing under water flow or immerse in liquids.
21. DO NOT plug in the cord with wet hands: electric shock could result.
22. DO NOT fill through openings other than intakes.
23. DO NOT block intakes or exhaust grills.
24. To prevent damage to surfaces, do not place humidifier under overhanging surfaces.

PLEASE READ AND SAVE THESE IMPORTANT SAFETY INSTRUCTIONS

Thank you for choosing a Holmes Cool Mist console humidifier. To ensure the best performance from your humidifier, please read and save the following instructions.

Consumer Safety Information

NOTE: This is an electrical appliance and requires attention when in use.

NOTE: If moisture forms on the walls or windows of the room, turn off the humidifier. The room already has plenty of humidity and additional moisture may cause damage.

Cord and Plug Installation Safety Instructions

The length of cord used on this appliance was selected to reduce the hazards of becoming tangled in, or tripping over a longer cord. If a longer cord is necessary an approved extension cord may be used. The electrical rating of the extension cord must be equal to or greater than the rating of the humidifier. Care must be taken to arrange the extension cord so that it will not drape over the countertop or tabletop where it can be pulled on by children or accidentally tripped over.

HOW COOL MIST WORKS

Your Holmes Cool Mist humidifier draws dry air through the rear air intake grill area. This air is then passed through a moisture-laden wick filter, which retains the minerals and deposits in the water. The resulting moist air is directed back into the room from the top air grill.

NOTE: This humidification system provides a cool, invisible moisture output. It is normal not to see the mist.

NOTE: A humidity level below 20% can be unhealthy and uncomfortable. The recommended humidity level is between 40%-50%.



THIS PRODUCT IS EQUIPPED WITH A POLARIZED AC (Alternating Current) PLUG (a plug having one blade wider than the other). This plug will fit into the power outlet only one way. If the plug does not fit fully into the outlet, reverse the plug. If it still does not fit, contact qualified personnel to install the proper outlet. **DO NOT DEFEAT THE SAFETY PURPOSE OF THIS POLARIZED PLUG IN ANY WAY.**

FEATURES - OPERATION

PRE-OPERATING INSTRUCTIONS

1. Push the 1 Touch™ (MODE/OFF) button for 2 seconds to turn the unit OFF, and disconnect from the electrical outlet.
2. Remove housing, filter and tanks (see figures 1 and 4).
3. TO PROVIDE ADDITIONAL MOBILITY AND CONVENIENCE TO YOUR CONSOLE HUMIDIFIER, install the wheels. Remove the four wheels located in a small pouch in the box. Turn the base upside down, and locate the holes at each of the four corners on the underside.

Note: You will notice that there are two different shaped wheels. Two of the 4 wheels are stationary wheels and two are swivel type wheels. The stationary wheels are identified by a flat top surface, while the swivel type are curved and include a small plastic piece on the shaft. (See figure 2 for installation location for each type of wheel.) DO NOT use any tools to install the wheel because tools may damage the base of the unit. Return the base to the upright position.

4. Choose a location out of reach of children. DO NOT place the humidifier on a finished floor or near furniture which can be damaged by moisture or water. Place on a moisture-resistant surface.

FILLING THE WATER TANK

1. Push the 1 Touch™ (MODE/OFF) button for 2 seconds to turn the unit OFF, and disconnect from the electrical outlet.
2. Remove the two tanks from the base of the humidifier and bring each tank to the faucet. Turn the tanks upside down and twist off the tank caps by turning counter-clockwise. Fill each tank with cool, fresh tap water. Replace the cap on each tank FIRMLY.
3. When full, carry each tank to the humidifier and place onto the base (use both hands when carrying each tank). Each tank holds 1.6 gallons of water, and the base holds .25 gallons of water.
4. Plug the power cord into the electrical outlet.

OPERATING INSTRUCTIONS

Your humidifier is equipped with a technologically advanced 1 Touch™ Electronic Humidistat. You can set the humidifier to run continuously in manual mode or set the 1 Touch™ Electronic Humidistat to your desired temperature setting. The 1 Touch™ Electronic Humidistat will automatically turn the humidifier ON or OFF, depending on the preset comfort level. The comfort level ranges between 35% and 55% relative humidity.

Manual Mode Instructions:

1. Plug the humidifier into a 120V AC electrical outlet.
2. To start the unit, push the MODE/OFF button once for the HIGH manual setting. (See figures 1 and 3.)
3. Press the button again for the LOW manual setting. (See figures 1 and 3.)
4. To stop the unit, press and hold the button for two seconds, or keep pressing the button until all the humidity indicators are OFF.

NOTE: In Manual Mode, only the LOW or HIGH power light will be lit.

1 Touch™ Humidistat Instructions

To take advantage of the 1 Touch™ Electronic Humidistat, press the MODE/OFF button until the speed is set in either the HIGH or LOW setting, and the Desired Humidity is set. When the humidity level rises above the set humidity, the humidifier will stop. When the humidity level drops below the set humidity, the humidifier will turn on automatically.

NOTE: When the 1 Touch™ Electronic Humidistat is set, either the HIGH or LOW power light and the percent humidity light will remain lit during operation. (See figures 1 and 3.)

NOTE: Allow up to 30 minutes for the filter to fully absorb water and for the unit to produce moisture.

NOTE: The 1 Touch™ Humidifier has memory. This means that when you turn the unit back on, it will be at the last setting the humidifier was set at.

If you do not plan to use the humidifier for two or more days, make sure any residual water is drained from the water tank, base and wick filter to prevent algae or bacteria growth.

Figure 1

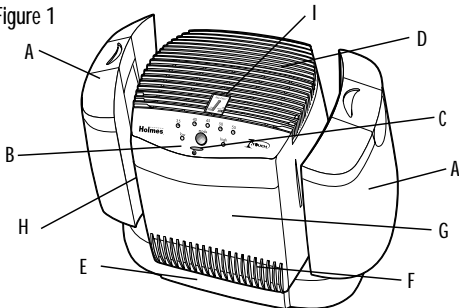

- | | |
|----------------------------|--|
| A. WATER TANKS | F. AIR INTAKE GRILLS |
| B. 1 TOUCH™ HUMIDISTAT | G. HUMIDIFIER HOUSING |
| C. REFILL LIGHT | H. COLOR-CODED FILTER CHANGE INDICATOR STICKER (not shown) |
| D. MOISTURE EXHAUST GRILLS | I. FILTER CHECK™ INDICATOR |
| E. HUMIDIFIER BASE | |

Figure 2 WHEEL INSTALLATION

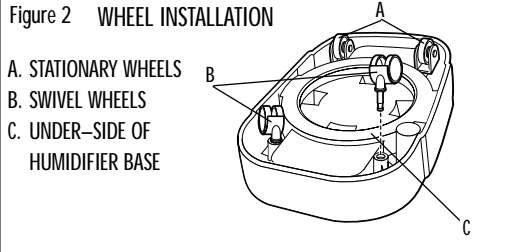

- A. STATIONARY WHEELS
- B. SWIVEL WHEELS
- C. UNDER-SIDE OF HUMIDIFIER BASE

Figure 3

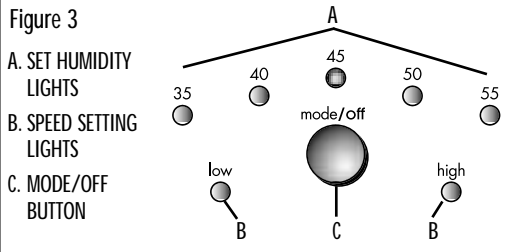

- A. SET HUMIDITY LIGHTS
- B. SPEED SETTING LIGHTS
- C. MODE/OFF BUTTON

REPLACING THE FILTER CLEANING INSTRUCTIONS - STORAGE

REPLACING THE FILTER

REPLACEMENT OF HOLMES® EXTENDED LIFE FILTERS:

Through normal use, waterborne minerals and sediment become trapped in the wick filter. The harder your water, the greater the amount of minerals in the water, and the more often you will need to change your filter.

You will be able to monitor the life of the filter in your humidifier by checking the Filter Check™ Indicator. When the unit is off, the Filter Check™ Indicator will read in the OFF position. After 60 minutes of use, Filter Check™ Indicator (refer to figure 5 for close-up of indicator) will move from the OFF position and indicate your filter condition. A brand new filter will register in the blue section reading GOOD filter. After frequent use of your humidifier, the Filter Check™ Indicator will let you know when the filter needs to be changed.

When the needle is in the red (CHANGE) section, this means the proper amount of moisture is not getting into your air due to the excessive minerals and sediment that have become trapped on your filter. At this point, you should replace your filter. It is important to change your filter as indicated to obtain stated performance level.

TO REPLACE THE FILTER:

1. Push the MODE/OFF button for 2 seconds to turn the unit off and unplug the humidifier. Lift off the housing of the unit, remove the used wick filter, and throw it away.
2. Remove the protective bag from the new wick filter and slide the filter down into the circular filter support in the base. Replace the housing, refill the tanks, plug the cord into the electrical outlet and press the MODE/OFF button to turn the unit on. Because the filter needs to absorb water to function properly, it will take about 30 minutes for the humidifier to reach the maximum moisture output (see figure 3).

NOTE: You can purchase replacement filters (model HWF75) at a local retailer, by calling 1-800-5-HOLMES, or by visiting www.holmesproducts.com. Please refer to the replacement Accessories section at the end of this manual. It is recommended that a replacement filter is purchased for uninterrupted use.

Figure 4

- A. CIRCULAR EXTENDED LIFE FILTER
- B. CIRCULAR FILTER SUPPORT
- C. FLOAT SWITCH
- D. HUMIDIFIER BASE

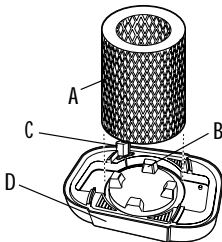

CLEANING AND MAINTENANCE INSTRUCTIONS

Humidifiers provide comfort by adding moisture to dry, heated indoor air. To benefit most from the humidifier and avoid product misuse, follow all instructions carefully. Please note that this is an electrical appliance and requires attention when in use.

In addition, if you do not follow the recommended care and maintenance guidelines, micro-organisms may be able to grow in the water within the Water Tank. You must routinely follow the cleaning procedures that follow in order to ensure proper, efficient operation of your humidifier. Proper maintenance and cleaning is essential to the continued performance of your unit and the avoidance of algae or bacteria build-up.

DAILY MAINTENANCE

1. Before cleaning, be sure the humidifier is OFF and disconnected from the electrical outlet.
2. Remove the housing and the tanks from the humidifier and place them in sink or tub.
3. Carry the base of the unit to the sink, remove the wick filter, drain any remaining water and rinse thoroughly to remove any sediment or dirt. Wipe clean, and dry with a clean cloth or paper towel.
4. Drain the water from the tanks into the sink and rinse each tank thoroughly. Wipe clean, and dry with a clean cloth or paper towel.
5. Put filter back in the filter supports, replace the housing, then refill the tanks with cool tap water as instructed earlier in the Filling Instructions. Do not overfill.
6. Follow Operating Instructions.

WEEKLY MAINTENANCE

To Remove Scale:

1. Repeat steps 1-4 above.
2. Partially fill the base with **Holmes Cleanse Clean™** (Model S1710) as instructed on bottle, or with two 8 oz. cups of undiluted white vinegar. Leave this solution in the base for 20 minutes, while cleaning all interior surfaces with a soft brush. Remove base scale by wiping the base with a cloth dampened with undiluted white vinegar.
3. Rinse with clean warm water to remove the cleaning solution before disinfecting the tank.

To Disinfect Humidifier Base and Tanks:

1. Fill Humidifier Base with 2 gallons of water and 1 teaspoon of chlorine bleach.
2. Fill each tank with .5 gallon of water and 1 teaspoon of chlorine bleach.
3. Let the solution stand for 20 minutes, swishing every few minutes. Wet all surfaces.
4. Carefully empty the Base and Tanks after 20 minutes, and rinse with water until you cannot detect any bleach smell. Dry with a clean cloth or paper towel.
5. Check the Filter Check™ Indicator to see if it is time to replace the filter. Depending on the water hardness in your area, it may be necessary to change the filter every 1-2 months. Re-insert the wick filter into the filter support.
6. Refill the water tanks as directed with cool tap water, replace the humidifier housing, and turn the Control Knob to ON.

TROUBLESHOOTING

Trouble	Probable Cause	Solution
Unit does not turn on.	Water spilled in humidistat.	Drain water from base and allow unit to dry for 15 minutes.
	Circuit breaker has been tripped.	Check circuit breaker.
Mist output minimal to none.	Filter has not absorbed water.	Wait 15 minutes before starting humidifier.
	Mineral buildup in tray.	See Weekly Maintenance under Cleaning and Maintenance Instructions. Regular cleaning is recommended to keep the unit functioning properly.
	Humidistat is set too low.	Raise the level of humidity by adjusting the humidistat (see Operating Instructions).
Water leaks from tank.	Filter needs to be replaced.	Replace your filter (HWF75) by calling 1-800-5-HOLMES, or visit www.holmesproducts.com .
	Rubber tank ring is missing or improperly placed.	Remove tank cap then replace or reposition ring.
Filter turns brown.	Cap not tight enough.	Tighten the cap.
	The filter needs to be replaced.	Replace your filter (HWF75) by calling 1-800-5-HOLMES, or visit www.holmesproducts.com .
Film on water tank.	Short filter life.	In areas with hard water the filter will need to be changed more frequently.
	Mineral deposits cause film on tank to build up.	See Daily Maintenance under Cleaning and Maintenance instructions. Regular cleaning is recommended to keep the unit functioning properly. To order Cleanse Clean™ (S1710), call 1-800-5-HOLMES, or visit www.holmesproducts.com .
Water in tanks appears cloudy.	Filter needs to be replaced.	Replace your filter (HWF75) by calling 1-800-5-HOLMES, or visit www.holmesproducts.com .
	Water tank filled with warm water.	Use cool water to fill the water tank – and only use Holmes® care products recommended in this manual.
Unit cycles on/off.	Humidifier is reacting to room.	Set the 1 Touch™ Electronic Humidistat to a higher or lower desired setting.
Very tight tank cap.	Tank cap over tightened.	Add liquid soap to cap gasket to ease opening.

STORAGE INSTRUCTIONS

When not using your humidifier for an extended period of time:

1. Dispose of the filter. DO NOT leave in unit.
2. Clean, rinse and thoroughly dry the humidifier as directed in weekly maintenance. DO NOT leave any water in the unit when storing. Leaving water in the unit may render the unit in-operable for the following season.
3. Place the humidifier in the original carton and store in a cool, dry place.
4. Order your Holmes replacement filter (HWF75) for next year's use.

REPLACEMENT ACCESSORIES

(see included Humidifier Accessory Form)

- Comfort Check hygrometer/thermometer
Reads humidity and temperature levels
- Digital HHG175:\$19.99
- Analog HHG150:\$12.99
- HWF75 Replacement Filter\$14.99
- SC1720 Cool Mist Care Pack\$14.99

(Complete care for your humidifier:

One bottle each of S1705, 1708, 1710)

Individual Bottles also available:

- S1705 Water Treatment\$5.99
- S1708 Bacteriostat Solution\$5.99
- S1710 Cleanse Clean™\$5.99

(plus shipping and handling)

WARRANTY INFORMATION

SERVICE INSTRUCTIONS

1. DO NOT attempt to repair or adjust any electrical or mechanical functions on this unit. Doing so will void your warranty.
2. If you have any questions on operation or believe any form of repair is necessary, please call 1-800-5-HOLMES to speak with a Consumer Service Representative.
3. If you need to exchange this product within the first 30 days, please return the unit in its original carton, with a sales receipt to the store from where you purchased it. After 30 days please review your warranty information.

If you have any questions or comments, or would like to order replacement accessories, please write or call us at:

The Holmes Group, Inc.
P.O. Box 769
Milford, MA 01757-0769

For your own records, staple or attach your sales receipt to this manual. Also, please take a moment to write the store name/location and date purchased below.

STORE NAME _____

LOCATION: _____

DATE PURCHASED: _____

(STAPLE RECEIPT HERE)

SIX (6) YEAR LIMITED WARRANTY

SAVE THIS WARRANTY INFORMATION

- A. The quality controls used in the manufacture of this Holmes product are to ensure your satisfaction.
- B. This Warranty applies only to the original purchaser of this product.
- C. This Warranty applies ONLY to repair or replacement of any supplied or manufactured parts of this product that, upon inspection by Holmes authorized personnel, proves to have failed in normal use due to defects in material or workmanship. Holmes will determine whether to repair or replace the unit. This Warranty does not apply to installation expenses.
- D. Operating this unit under conditions other than those recommended or at voltages other than the voltage indicated on the unit, or attempting to service or modify the unit, will render this WARRANTY VOID.
- E. **Unless otherwise proscribed by law, Holmes shall not be liable for any personal injury, property or any incidental or consequential damages of any kind (including water damage) resulting from malfunctions, defects, misuse, improper installation or alteration of this product.**
- F. All parts of this Holmes product are guaranteed for a period of 6 years as follows:
 1. Within the first 30 days from date of purchase, the store from which you purchased your Holmes product should replace this product if it is defective in material or workmanship (provided the store has in-stock replacement.)
 2. Within the first seventy-two months from date of purchase, subject to the conditions in paragraph H, Holmes will repair or replace the product if it is defective in material or workmanship providing it is returned to Holmes, freight prepaid, with PROOF OF PURCHASE date, together with \$10.00 for handling and return packing/shipping charges.
- G. If you have any problem with this product, please write our Consumer Service Dept., or call, 1-800-5-HOLMES.
- H. **IMPORTANT Return INSTRUCTIONS** Your warranty depends on your following these instructions if you are returning the unit more than 30 days after the date of purchase:
 1. Carefully pack the item in its original carton or other suitable box to avoid damage in shipping.
 2. Before packing your unit for return; be sure to enclose:
 - a) your name, full address with zip code and telephone number,
 - b) a dated sales receipt or PROOF OF PURCHASE,
 - c) your \$10.00 check for return packaging, and
 - d) The model number of the unit and the problem you are having. (Enclose in an envelope and tape directly to the unit before the box is sealed.)
 3. Holmes recommends you insure the package (as damage in shipment is not covered by your warranty).
 4. All shipping charges must be prepaid by you (as noted in paragraph F).
 5. Mark the outside of your package:

CONSUMER SERVICE DEPARTMENT
THE HOLMES GROUP, INC.
2 PULLMAN STREET
WORCESTER, MA 01606

SHIPPING AND HANDLING CHARGES: \$10.00

This warranty gives you specific legal rights, and you may have other rights which vary from state to state. The provisions of this warranty are in addition to, and not a modification of, or subtraction from, the statutory warranties and other rights and remedies contained in any applicable legislation. To the extent that any provision of this warranty is inconsistent with any applicable law, such provision shall be deemed voided or amended, as necessary, to comply with such law.