

Part Number P110-LFP1025A, P110-WTR2019A,  
P110-LBP2018A, P110-SFP1016A,  
P110-SBP2017A

**GENERAL**

Congratulations on your excellent choice in this addition to your home comfort system.

Your humidifier represents both the latest in engineering development and the culmination of many years of experience from one of the most reputable manufacturers of comfort systems.

Your new unit is among the most energy-efficient and reliable home humidifiers available today. To assure its dependability, spend a few minutes now with this booklet. Learn about the operation of your humidifier and the small amount of maintenance it takes to keep it operating at peak efficiency.

During the heating season, your home can become uncomfortably dry. This is because cold winter air holds very little moisture. When outdoor air is warmed to average room temperature, its relative humidity falls to even lower levels.

Proper humidity control can alleviate problems caused by excessive dryness. The additional moisture supplied by your humidifier may enable you to reduce the temperature setting on your thermostat — without any loss of indoor comfort.

Your humidifier adds water to the air inside your home. Although the rate of humidification is variable, it may exceed one-half gallon of water per hour. The typical process of humidification begins when water flows through the humidifier valve and soaks the large evaporator pad. Hot, dry air from the furnace passes through the pad and absorbs the water. Then, this moisture-laden air is distributed throughout the house via the ductwork. See Fig. 1. Typical humidifier installations are shown in Fig. 2.

**OPERATING YOUR HUMIDIFIER**

Your new humidifier is designed to operate as part of your home heating system. For performance at maximum efficiency, follow these recommendations:

- The humidifier is controlled by a humidistat. Adjust the humidistat setting according to the outside temperature. Refer to Table 1 as a general guide. If after several days, the air in your home is too moist, lower the humidistat setting. Condensation on single-pane windows indicates excessive moisture. If the air is too dry, increase the setting.
- Continuous blower operation provides for constant humidification. Continuous blower operation also minimizes temperature differences throughout the home. Furthermore, a system equipped with an electronic air cleaner offers the added benefit of full-time air filtration.
- Supply- and return-air grilles should not be blocked by drapes, furniture, or other objects. Restricted airflow reduces the efficiency of the humidifier, as well as that of the whole comfort system.

- The humidifier unit must be properly maintained on a regular basis.

**Table 1 — Humidistat Settings**

OUTSIDE TEMPERATURE (°F)	RECOMMENDED HUMIDISTAT SETTING (% RELATIVE HUMIDITY)
-20	15
-10	20 (LOW)
-0	25
10	30
20	35
30	40 (MED)

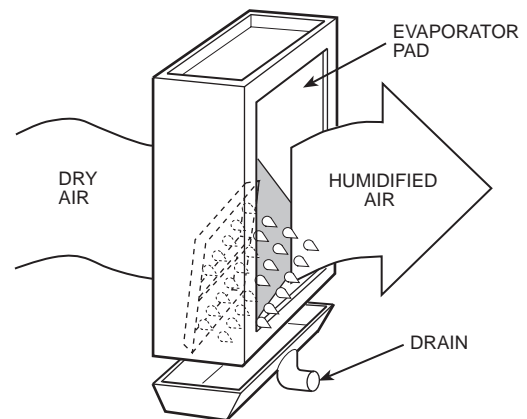

**Fig. 1 — Humidifier Operation**

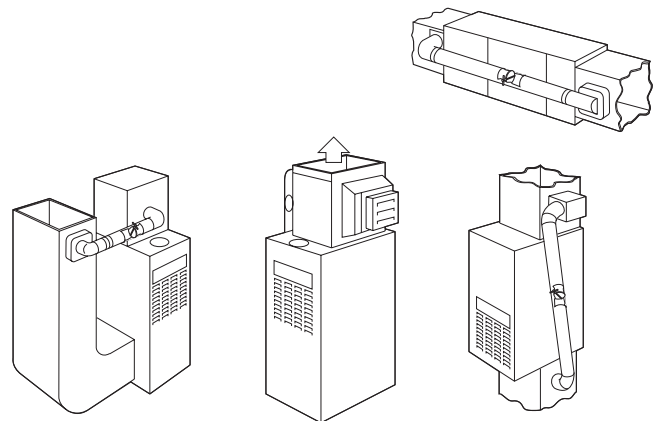

**Fig. 2 — Typical Humidifier Installations**

## Start-Up Procedures

1. Open the saddle valve on the water supply line. (See Fig. 3.) Set humidistat to the desired relative humidity. (See Fig. 4 and Table 1.)
2. Turn the furnace on and adjust the thermostat to a high temperature setting. Be sure that the furnace blower is operating.
3. Check to see if water is flowing into the humidifier.
  - On P110-L8P2018A or P110-LFP1025A humidifiers, loosen the thumbscrew that holds the distributor cover to the top of the cabinet. Lift up the distributor cover slightly to make certain that water is flowing from the solenoid valve into the distributor pan. Do not lift the cover off the cabinet more than 1 in. when water is flowing. (See Fig. 5 or 6.)
  - On a P110-SBP2017A humidifier, gently pull the latch that secures the access door. Remove the door. Check to see if water is flowing from the solenoid valve into the evaporator pad. (See Fig. 7.)
  - On a P110-SFP1016A humidifier, open the side door or the front cover. If the front cover is opened, hold the pad assembly in place. Check to see if water is flowing from the solenoid valve into the distributor pan. (See Fig. 8.)
  - On a P110-WTR2019A humidifier, look through the window on front of the unit to see that the evaporator pad is rotating and water is flowing. (See Fig. 9.)

The P110-WTR2019A humidifier is controlled by a float valve. Turning off the furnace will not affect the water flow until float level is achieved.

4. Turn off the furnace. When the blower stops, look into the humidifier to make sure the water is not flowing into the unit.
5. Replace the cover assembly and fasten securely.
6. Now, turn the furnace on and set the thermostat for desired room temperature.

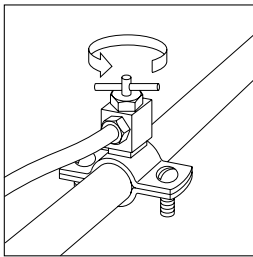

**Fig. 3 — Saddle Valve**

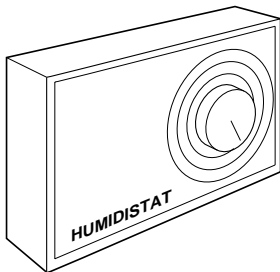

**Fig. 4 — Humidistat**

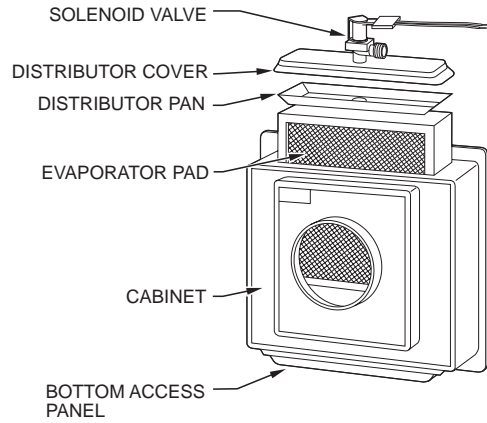

**Fig. 5 — Humidifier Details — P110-LBP2018A**

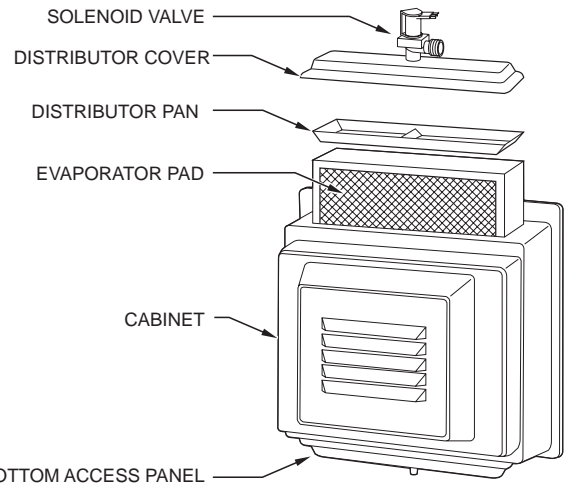

**Fig. 6 — Humidifier Details — P110-LFP1025A**

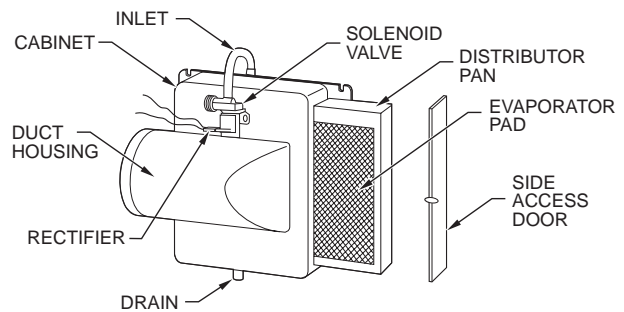

**Fig. 7 — Humidifier Details — P110-SBP2017A**

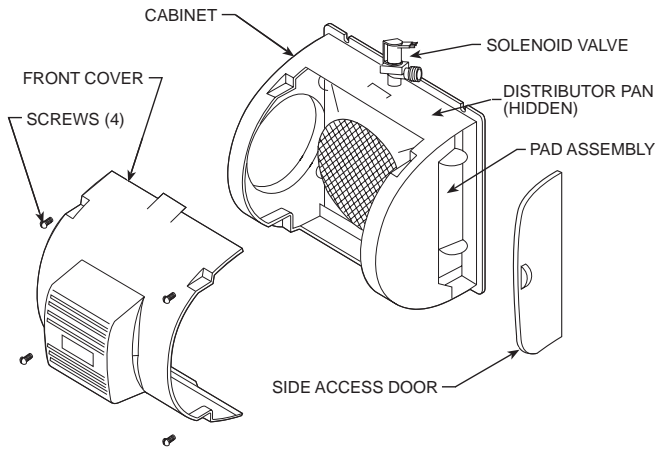

**Fig. 8 — Humidifier Details — P110-SFP1016A**

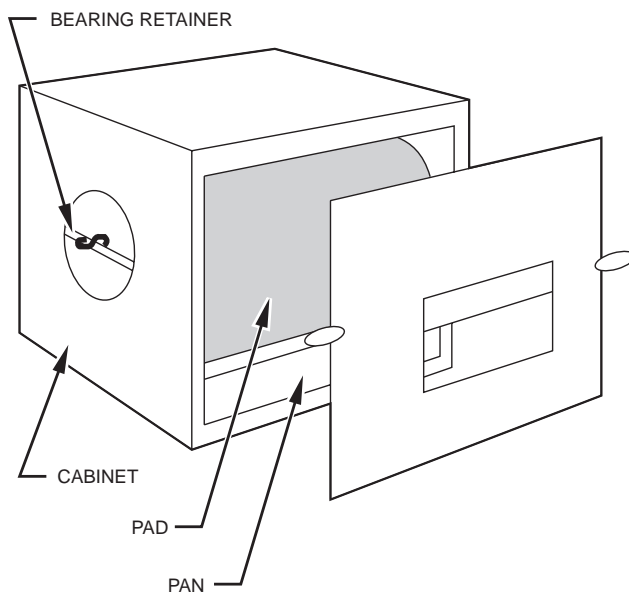

**Fig. 9 — Humidifier Details — P110-WTR2019A**

**Shutdown Procedures** — To shut down your humidifier, close the saddle valve on the water line. Then turn off the humidistat. When set to the OFF position, the humidistat shuts off the electrical power to the solenoid valve on the humidifier.

**NOTE:** If your home comfort system includes cooling, be sure the water supply to your humidifier is **turned off** during the cooling season. Close the damper located in the bypass duct if one is installed. If your humidifier is a part no. P110-WTR2019A, drain and clean the water pan as described in cleaning procedures.

### PERFORMING ROUTINE MAINTENANCE

With the proper maintenance and care, your humidifier will operate economically and dependably. Maintenance can be accomplished easily by referring to the following directions. However, before performing any maintenance, consider these important safety precautions:

#### **⚠ WARNING**

Disconnect all electrical power to the humidifier and furnace before performing any service or maintenance to avoid personal injury or death.

**NOTE:** There may be more than one electrical disconnect switch.

#### **⚠ CAUTION**

Although special care has been taken to minimize sharp edges in the construction of your humidifier, be extremely careful when handling parts or reaching into the unit to avoid personal injury.

Your humidifier has been designed for easy disassembly to simplify cleaning and servicing. Your unit must be kept clean to maintain its efficiency.

Regular inspection allows you to determine the cleaning schedule best suited to your humidifier's operating conditions. The frequency for required maintenance will depend most upon the available water supply. In areas where hard water and high mineral content are prevalent, more frequent cleaning and servicing may be required.

At minimum, the humidifier will need to be cleaned at the beginning of every heating season.

### Cleaning Procedures

P110-LBP2018A, P110-SBP2017A, P110-LFP1025A, AND P110-SFP1016A HUMIDIFIERS

1. Turn off all electrical power to the humidifier and furnace or fan coil.
2. Turn off the humidifier's water supply. (See Fig. 3.)
3. Disassemble the humidifier.
  - To disassemble a P110-SBP2017A humidifier, gently pull the latch that secures the access panel. Remove the door and slide the evaporator pad assembly out of the unit. (See Fig. 7.)
  - To disassemble either a P110-LBP2018A or P110-LFP1025A humidifier, first remove the water supply connection to the solenoid valve. Next, remove the screw that holds the distributor cover to the cabinet, and lift off the cover. Disconnect the drain line from the sump and loosen the thumbscrew(s) holding the sump to the cabinet. Remove the sump. Remove evaporator pad assembly. (See Fig. 5 or 6.)
  - To disassemble a P110-SFP1016A humidifier, the pad assembly can be removed from the side access door or the front cover. When removing the side door, lift the pad assembly up by holding the tabs and slide the assembly out. When removing the front cover, disconnect the quick connects to the solenoid valve, unscrew the 4 screws to the front cover, snap loose the top and bottom catches, and lay the front cover aside. Once the front cover is off, lift the pad assembly up and twist it out. The pad assembly consists of 4 parts; the distributor pan, frame, sump, and the evaporator pad. Pull the distributor pan apart from the frame and the evaporator pad can be removed. Do not force the evaporator pad in or out without removing the distributor pan as this will distort the pad. See Fig. 8.
4. Clean the humidifier's external components.
  - If your humidifier is a P110-SBP2017A humidifier, wash the access door and outlet drain portion of the cabinet. Make sure the drain is open.
  - If your humidifier is a P110-LBP2018A, P110-SFP1016A, or P110-LFP1025A unit, wash the distributor cover, sump cover, and cabinet. Be sure the inlet ports are open and clean. Then, clean the sump with a solution of detergent and water.
5. Clean the internal components of your humidifier. Wash the distributor pan with a mild detergent and warm water. Be sure holes and slots in the pan are clean and unobstructed. Wash the evaporator pad assembly in a detergent solution. If there are scale deposits on the pad, soak

it in ordinary household vinegar. If the pad is covered by a heavy deposit of scale, or if the local water supply has high sulfate or calcium content, replace the pad with a new one. Contact your dealer for replacement part.

6. Reassemble your humidifier.
7. Turn on the electrical power and water supplies. Refer to the start-up procedures.

#### P110-WTR2019A HUMIDIFIERS

1. Turn off all electrical power to the humidifier and furnace or fan coil.
2. Turn off the humidifier's water supply. (See Fig. 3.)
3. Drain water from the unit. Place a pail underneath the drain plug located on the bottom of the humidifier cabinet. Lift the tab on the drain plug and remove the plug. Allow all water to drain from the unit. (See Fig. 10.)
4. Remove the front door from the humidifier. Rotate the latches one-half turn, then pull the door forward.
5. Remove and inspect the evaporator pad assembly. Lift the bearing from its retainer. (See Fig. 9.) Pull the assembly away from the motor to disengage the assembly shaft from the motor coupling. Remove assembly through the access opening.

Inspect the evaporator pad. If the pad is heavily loaded with scale, or if the local water has a high sulfate content, replace the pad. Contact your dealer for replacement part.

NOTE: For best performance, the evaporator pad should be replaced before each heating season.

6. Inspect the float assembly. Remove the float arm from the valve body by sliding out the pin and lifting off the float arm. (See Fig. 11.) Inspect the rubber valve seat located inside the float arm. If the seat appears to be nicked or worn, invert the seat or replace it with the spare valve seat located on the float arm. Inspect the water opening in the valve body. If the opening is clogged, use a pin to remove the obstruction. Remove any accumulated deposits from the valve body and float arm.

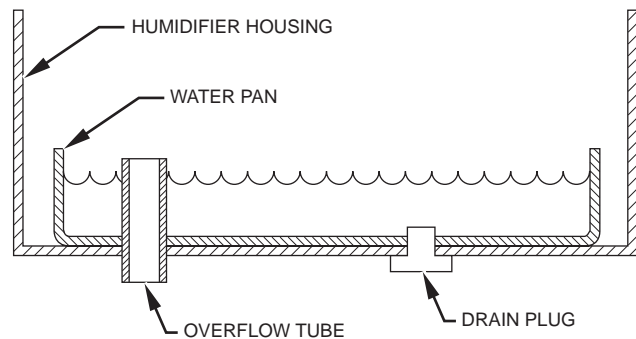

**Fig. 10 — Cleaning Water Pan and Unit Cabinet — P110-WTR2019A**

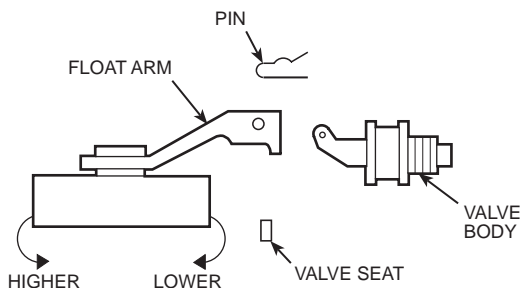

**Fig. 11 — Float Arm Removal — P110-WTR2019A**

7. Clean the water pan and unit cabinet. Tilt the water pan and lift it from the unit. Wash the pan with warm, soapy water. Flex the pan to loosen accumulated scale. Wash the unit interior, removing any accumulated deposits. Inspect the drain line to ensure that no blockage has occurred. Clean as required. (See Fig. 10.)
8. Reassemble your humidifier. Reinsert the water pan and drain plug. Ensure that the overflow tube is inserted into the hole at the bottom of the cabinet. Attach the float arm to the valve body by aligning the holes on both parts and reinserting the pin. *Do not force or bend the pin.* The float arm should have free up-and-down movement. Install the evaporator pad assembly. Ensure that the square shaft engages the motor coupling and that the bearing washer is located inside the bearing retainer. Turn the water on. Adjust float by rotating until water covers inside of foam drum. Attach the access door and turn the latches.
9. Turn on electrical power supplies. Refer to start-up procedures listed on page 2.

### BEFORE YOU REQUEST A SERVICE CALL

#### Before You Call For Service, Check For These Easily Solved Problems:

- Check the main power disconnect switch. Verify that the circuit breakers are on and that fuses have not blown. If you must reset breakers or replace fuses, do so only once. Contact your servicing dealer for assistance if the breakers trip or the fuses blow a second time.
- If the humidity level is too low, check the humidistat setting. Confirm that the saddle valve is turned on. Check the evaporator pad, and clean or replace the pad as necessary. Check water level in P110-WTR2019A humidifier.
- Check for sufficient airflow. Check the furnace filter or electronic air cleaner for excessive accumulations of dirt. Check for blocked return- or supply-air grilles. Be sure grilles are open and unobstructed.
- If water drips from the humidifier, check the drain hose for kinks or obstructions. On P110-WTR2019A humidifiers, dripping may indicate that the float valve requires adjustment.
- If your comfort system still fails to operate properly, contact your servicing dealer for troubleshooting and repairs. Specify your apparent problem, and state the model and serial numbers of your equipment. (You should have them recorded where noted in this booklet.) With this information, your dealer may be able to offer helpful suggestions over the phone, or save valuable time through knowledgeable preparation for the service call.

**Regular Dealer Maintenance —** In addition to the routine maintenance that you perform, your humidifier should be inspected regularly by a properly trained service technician. The inspection (preferably each year, but at least every other year) should include the following:

- Routine inspection of the humidifier. Cleaning, if necessary. Cleaning or replacement of the evaporator pad as required.
- A check of all electrical wiring and connections.
- A check of water connections to the unit.
- Operational check of the complete comfort system to determine actual working condition. Necessary repair and/or adjustment should be performed at this time.

Your servicing dealer may offer an economical service contract that covers seasonal inspections. Ask for further details.

### SERVICE INFORMATION

Record the model and serial numbers of your new humidifier in the following spaces. This information, along with the other ready-reference facts requested below, may be required if you should ever need information or service.

Model No. \_\_\_\_\_

Serial No. \_\_\_\_\_

Date Installed \_\_\_\_\_

Dealer Name \_\_\_\_\_

Address \_\_\_\_\_

City \_\_\_\_\_

State \_\_\_\_\_ Zip \_\_\_\_\_

Telephone \_\_\_\_\_

**TOTALINE®**  
Humidifier  
Limited Warranty



**IF YOUR UNIT DOES NOT WORK, FOLLOW THESE STEPS IN ORDER:**

**FIRST:** Contact the installer. You may find his name on the product or in your Homeowner's Packet. If his name is not known, call your builder if yours is a new residence.

**SECOND:** Contact the Totaline distributor. (See telephone yellow pages or call 1-800-28HVACR)

Unit Model No. \_\_\_\_\_ Unit Serial No. \_\_\_\_\_

Date of Installation \_\_\_\_\_ Installed By \_\_\_\_\_

Name of Owner \_\_\_\_\_ Address of Installation \_\_\_\_\_

**ONE-YEAR WARRANTY** — This Totaline product is warranted to be free from defects in material and workmanship under normal use and maintenance for a period of one year from the date of original installation, whether or not actual use begins on that date. A new or remanufactured part to replace any defective part will be provided at Totaline's sole option without charge for the part itself, PROVIDED the defective part is returned to our distributor. This warranty applies only to the product in its original installation location and is voided if the product is reinstalled elsewhere.

THIS WARRANTY DOES NOT INCLUDE LABOR or other costs incurred for diagnosing, repairing, removing, installing, shipping, servicing or handling of either defective parts or replacement parts. SUCH COSTS MAY BE COVERED BY a separate warranty provided by the installer.

**EXTENDED FOUR-YEAR WARRANTY ON ELECTRICAL COMPONENTS** — During the second through fifth years after the date of original installation, Totaline further warrants the electrical components against defects in material or workmanship under normal use and maintenance. A new or remanufactured part will be provided at Totaline's sole option without charge for the part itself. The same conditions as stated in the one-year warranty apply.

**LIMITATION OF WARRANTIES** — ALL IMPLIED WARRANTIES (INCLUDING IMPLIED WARRANTIES OF MERCHANTABILITY) ARE HEREBY LIMITED IN DURATION TO THE PERIOD FOR WHICH THE LIMITED WARRANTY IS GIVEN. SOME STATES DO NOT ALLOW LIMITATIONS ON HOW LONG AN IMPLIED WARRANTY LASTS, SO THE ABOVE LIMITATIONS MAY NOT APPLY TO YOU. THE EXPRESSED WARRANTIES MADE IN THIS WARRANTY ARE EXCLUSIVE AND MAY NOT BE ALTERED, ENLARGED, OR CHANGED BY ANY DISTRIBUTOR, DEALER, OR OTHER PERSON WHATSOEVER.

ALL WORK UNDER THE TERMS OF THIS WARRANTY SHALL BE PERFORMED DURING NORMAL WORKING HOURS. ALL REPLACEMENT PARTS, WHETHER NEW OR REMANUFACTURED, ASSUME AS THEIR WARRANTY PERIOD ONLY THE REMAINING TIME PERIOD OF THIS WARRANTY.

**TOTALINE WILL NOT BE RESPONSIBLE FOR:**

1. Normal maintenance as outlined in the installation and servicing instructions or owners manual including coil cleaning, filter cleaning and/or replacement and lubrication.
2. Damage or repairs required as a consequence of faulty installation or application by others.
3. Failure to start due to voltage conditions, blown fuses, open circuit breakers or other damages due to the inadequacy or interruption of electrical service.
4. Damage or repairs needed as a consequence of any misapplication, abuse, improper servicing, unauthorized alteration or improper operation.
5. Damage as a result of floods, winds, fires, lightning, accidents, corrosive atmosphere or other conditions beyond the control of Totaline.
6. Parts not supplied or designated by Totaline.
7. Totaline products installed outside the continental U.S.A., Alaska, Hawaii and Canada.
8. Electricity or fuel costs or increases in electricity or fuel costs from any reason whatsoever including additional or unusual use of supplemental electric heat.
9. ANY SPECIAL, INDIRECT OR CONSEQUENTIAL PROPERTY OR COMMERCIAL DAMAGE OF ANY NATURE WHATSOEVER. Some states do not allow the exclusion of incidental or consequential damages, so the above limitation may not apply to you.

This warranty gives you specific legal rights, and you may also have other rights which vary from state to state.

Replacement Components Division • Carrier Corporation 9/90



**TOTALINE®**

Your Assurance of Quality

**ALL Totaline products are backed with a one-year warranty by Carrier Corporation, the world's largest manufacturer of air conditioning, heating, and refrigeration products.**