

This Owner's Manual is provided and hosted by [Appliance Factory Parts](#).

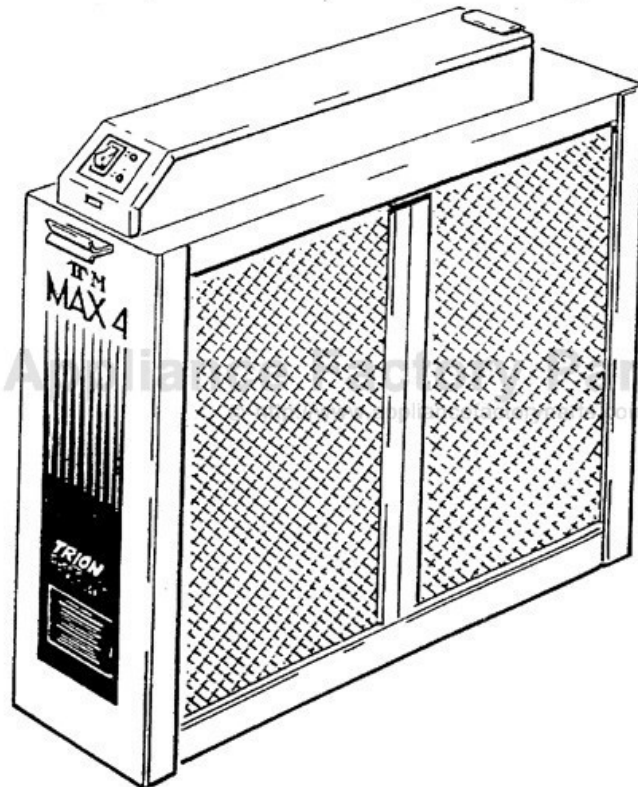

# HERRMIDIFIER MAX 4 2000 Owner's Manual

[Shop genuine replacement parts for HERRMIDIFIER  
MAX 4 2000](#)



[Find Your HERRMIDIFIER Humidifier Parts - Select From 41 Models](#)

----- Manual continues below -----

# **TRION**

## **DUCT MOUNT ELECTRONIC AIR CLEANER**

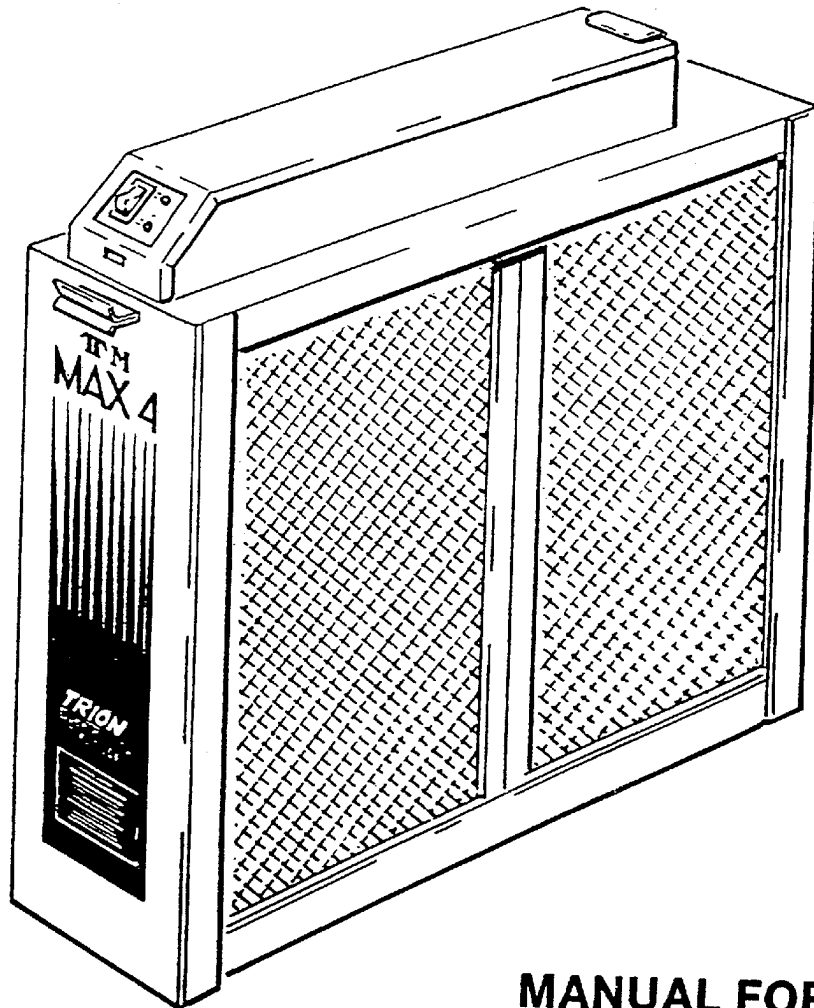

### **MANUAL FOR:**

- **INSTALLATION**
- **OPERATION**
- **SERVICE**
- **MAINTENANCE**

**CAUTION:** Read installation instructions and rules carefully for safe operation.  
Exercise the usual precautions when working with high voltage.

## TABLE OF CONTENTS

INTRODUCTION .....	1
PLANNING THE INSTALLATION .....	1
INSTALLATION .....	2
ELECTRICAL WIRING .....	3
SYSTEM CHECK OUT .....	5
TROUBLESHOOTING .....	5
OTHER FACTS YOU SHOULD KNOW .....	7
MAINTENANCE .....	9
PARTS LIST .....	10
QUICK REFERENCE TROUBLE CHART .....	12

MAX 4-1400, 2000  
TRIM

This manual provides information for location, installation, operation and service. Before installation and use of the air cleaner, carefully read these instructions to insure maximum benefits from the unit and to avoid needless service cost that can result from improper installation.

## I. INTRODUCTION

This electronic air cleaner is technically known as a two-stage electrostatic precipitator. It is designed to remove airborne particles - dust, dirt, smoke - from indoor air.

Air movement through the unit is controlled by the heating and/or air conditioning system blower. As dirty air enters the unit it passes through a pre-filter. The pre-filter strains out carpet lint, pet hair and other large particles by direct impingement.

The pre-filtered air then passes through a two stage electrostatic precipitator. In the first stage of electrical operation, all airborne particles, even of submicroscopic size, are electrically charged (positive) as they pass through the ionizer. In the second stage of operation, the charged particles pass into an electrical field established between a series of parallel plates, forming the negative element of the field. Here the positively charged particles are attracted to the plates.

## II. PLANNING THE INSTALLATION

Because air handling systems vary greatly in arrangement and style, factors such as accessibility, ambient temperature ratings, transitions and other requirements must be carefully considered.

The unit must be readily accessible for periodic inspection and cleaning of the protective screens and electronic cells to maintain maximum efficiency and trouble-free operation. When selecting the unit location for a Trim-T unit, allow a minimum of 25" clear space in front of the access panel and 12" of clear space above the power pack cover plate for component removal and service space. For a double pre-filter unit, allow a minimum of 18" clear space in front of the access panel and 12" of clear space above the power pack cover plate for component removal and service space.

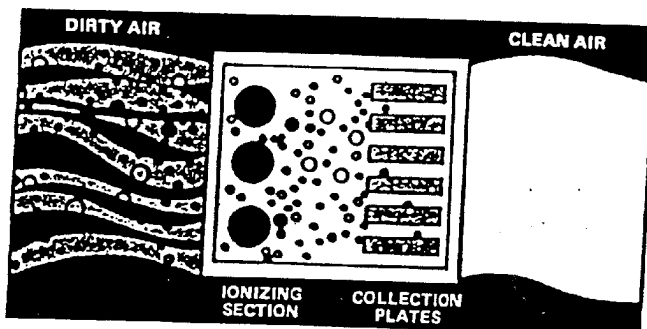

The air cleaner can only remove the airborne contaminants delivered to it by the ventilating system. To obtain maximum efficiency, adjust the system blower controls for continuous or as near continuous operation as practical.

### \*Air Conditioning

Whenever possible, install the electronic air cleaner upstream of the cooling coils.

### \*Humidifiers

Location of the system humidifier is important to the operation of the air cleaner. When an evaporative type humidifier is used, it may be installed between the furnace warm air duct and the return air duct without affecting the electronic air cleaner. Atomizing and spray type humidifiers should be installed downstream of the air cleaner. If it must be installed upstream, allow at least 6' between air cleaner and humidifier.

## SPECIFICATIONS

MODEL	MAX 4 1400	MAX 4 2000	TRIM-T
Rated Capacity	1400 CFM (2520 m <sup>3</sup> /hr.)	2000 CFM (3600 m <sup>3</sup> /hr.)	800 - 2000 CFM (3600 m <sup>3</sup> /hr.)
Max. Pressure Drop	.17 in. w.g. @ 1400 CFM	.19 in. w.g. @ 2000 CFM	.16 in. w.g. @ 2000 CFM
Cell Weight	(2) 9½ lbs. ea.	(2) 11 lbs. ea.	(2) 5 lbs. ea.
Unit Weight	43 lbs.	49 lbs.	30 lbs.
Power Consumption	40 watts maximum	48 watts maximum	40 watts maximum
Electrical Input	120 V, 60 HZ, 1 PH	120 V, 60 HZ, 1 PH	120 V, 60 HZ, 1 PH
Electrical Output	2.5 MA @ 6800 VDC	3.2 MA @ 6800 VDC	2.5 MA @ 6800 VDC

When outdoor air is added to the return air duct, sufficient heat should be added to maintain the return air temperature at 40° F (4° C) minimum. Lower temperatures can cause ionizer wire failure under certain conditions.

**CAUTION:** Only a trained, experienced serviceman should install this electronic air cleaner. Power supply should be disconnected before installation and a thorough checkout of the unit installation should be completed before unit operation.

**THIS AIR CLEANER SHOULD NOT BE INSTALLED ON THE HOT AIR SIDE OF DUCT-TYPE SYSTEMS.**

#### \*Sheet Metal Installation

The electronic air cleaner is adaptable to all new or existing residential forced air furnace or cooling systems.

#### \*Transitions

If the air duct does not fit the air cleaner cabinet opening: (1) Gradual transitions are recommended to reduce air turbulence thru the air cleaner to maximize efficiency. (2) Not more than 20" (about 4" per running foot) of expansion should be used on each side of the transition fitting.

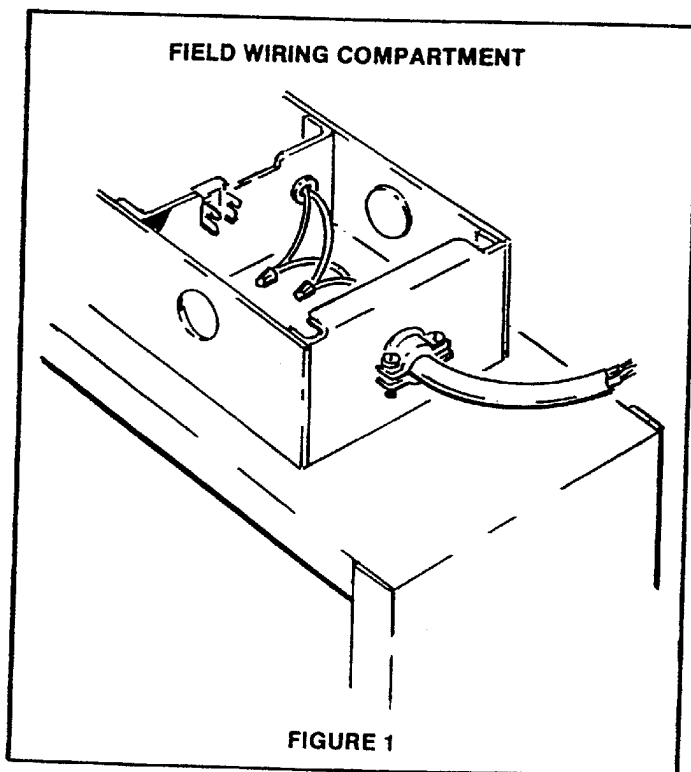

#### Turning Vanes

If the air cleaner is installed adjacent to a 90° duct elbow, add turning vanes inside the duct to improve the air distribution across the face of the air cleaner.

### III. INSTALLATION

1. Remove unit access panel, and slide the pre-filter(s) and ionizing-collecting cells out of the cabinet. Place them safely aside with the warranty registration card.
2. Locate the cabinet in the cold air return duct so that all of the return air flows thru the unit. It may be positioned for air flow in any direction: horizontal, left or right, vertical, up or down, or at an angle to the duct work. Maintain adequate space in front of the unit (18") for component removal and above the power pack (12") for service. Holes are provided for duct work attachment. The .140" holes are sized for number eight sheet metal screws and will also accommodate a number six sheet metal screw or 1/8" rivet. If the adjoining duct work is flanged, install the screws so that the screw heads are inside the cabinet to permit easy installation of the pre-filter(s) and an optional charcoal filter. When adjoining duct work has been secured, seal seams air tight with duct tape or caulking.

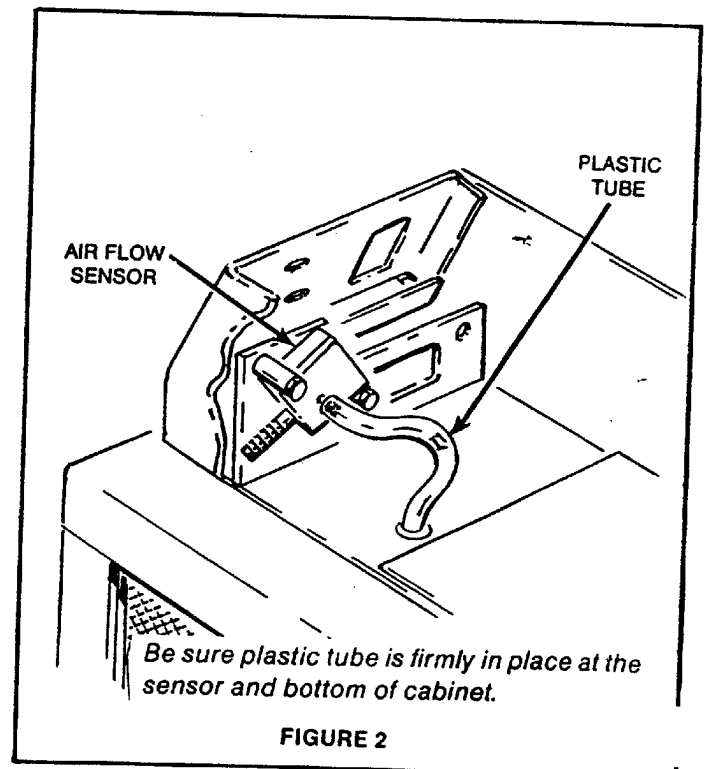

3. Reinstall the pre-filter(s) on the air entering side of the cabinet.
4. To change the air flow direction, a positioning screw is located inside the bottom of the cabinet to index the installation of the ionizing-collecting cells in the proper position with respect to airflow. The screw must be installed in the hole provided closest

to the air leaving side of the cabinet. Install the screw in the proper hole, seal the hole not used with duct tape and reinstall the cells. The directional arrows on the cell end plates must point in the direction of airflow.

5. Reinstall cabinet access panel.

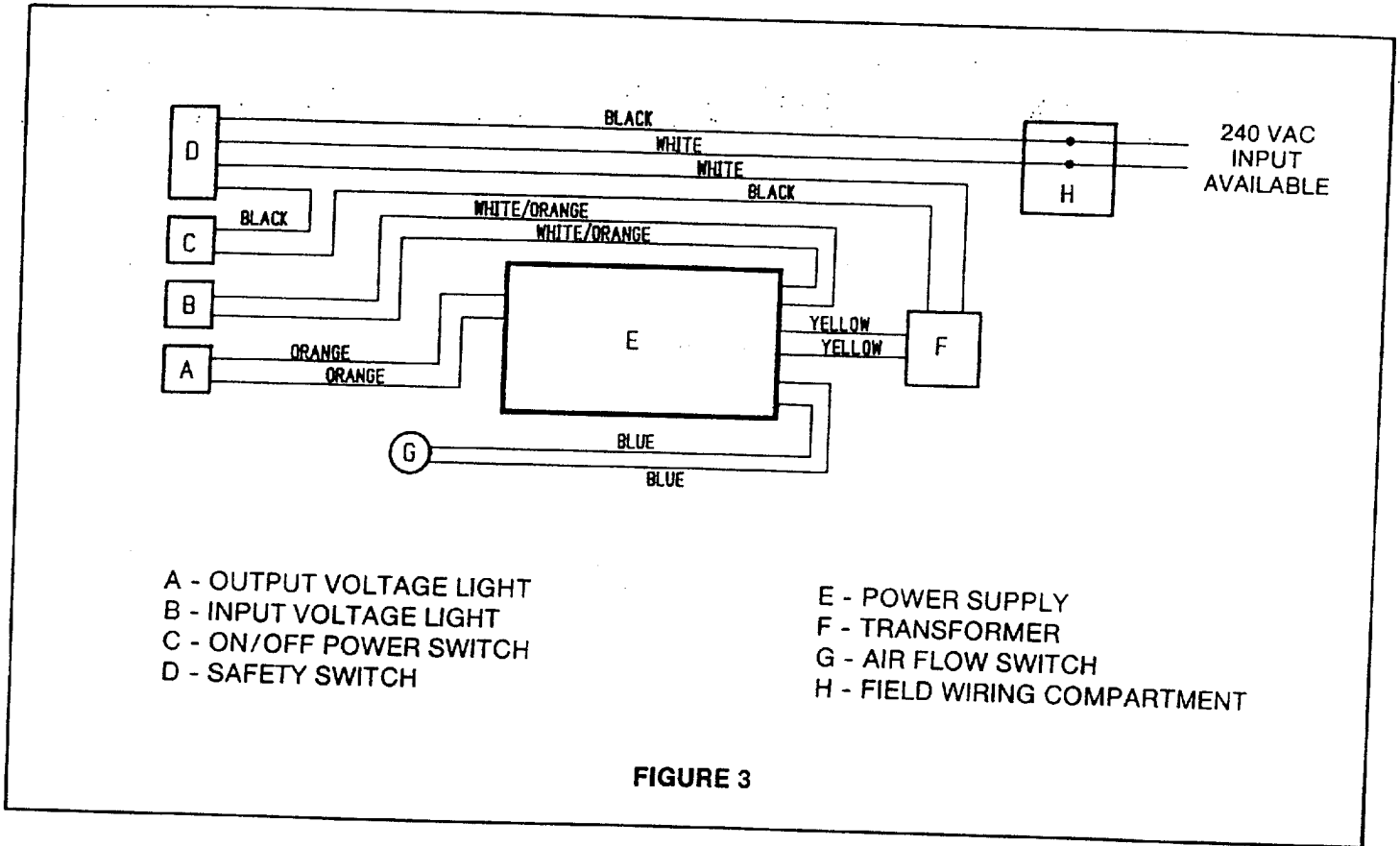

#### IV. ELECTRICAL WIRING

The Trion MAX 4 and Trim-T models are simple to wire. The 120 VAC power can be picked up from any convenient source. **It is not necessary to install relays or sail switches to insure air cleaner operation with the blower system.**

This electronic air cleaner has a **BUILT-IN AUTOMATIC AIR FLOW SENSOR**. The location of the air flow sensor is shown in Figure 2, page 2.

If your requirements call for a **240 VAC power supply**, this is available from the factory on special request.

#### PROCEDURE

1. Remove power pack cover plate.
2. Wire unit to 120 volt, 60 Hertz, 1 phase supply. The air flow sensor will automatically cycle your Trion electronic air cleaner with the blower system. The sensor is activated when the fan is on and air flow is present in the duct. It is preset at the factory and needs no adjustment (Figure 2, page 2.)

#### INPUT POWER

##### 120 Volt

If for some reason you find it necessary to connect the air cleaner to operate in conjunction with a multi-speed motor, a device such as a sail switch, an extra 120 VAC double pole, a double throw relay must be used (Ref. Figure 4, page 4.) The air flow sensor built into your Trion air cleaner makes it unnecessary to do the additional wiring under normal conditions.

# WARNING

IMPROPER FIELD WIRING WILL VOID ALL WARRANTIES ON THIS PRODUCT.

**NOTE:** DIRECT WIRING TO A MULTI-SPEED BLOWER MOTOR WILL CAUSE FAILURE OF THE POWER SUPPLY IN THIS UNIT.

PLEASE REFER TO THE FOLLOWING TYPICAL WIRING DIAGRAMS FOR PROPER INSTALLATION.

REMOVE CARDBOARD PACKING INSERT FROM TOP OF COLLECTING CELLS.

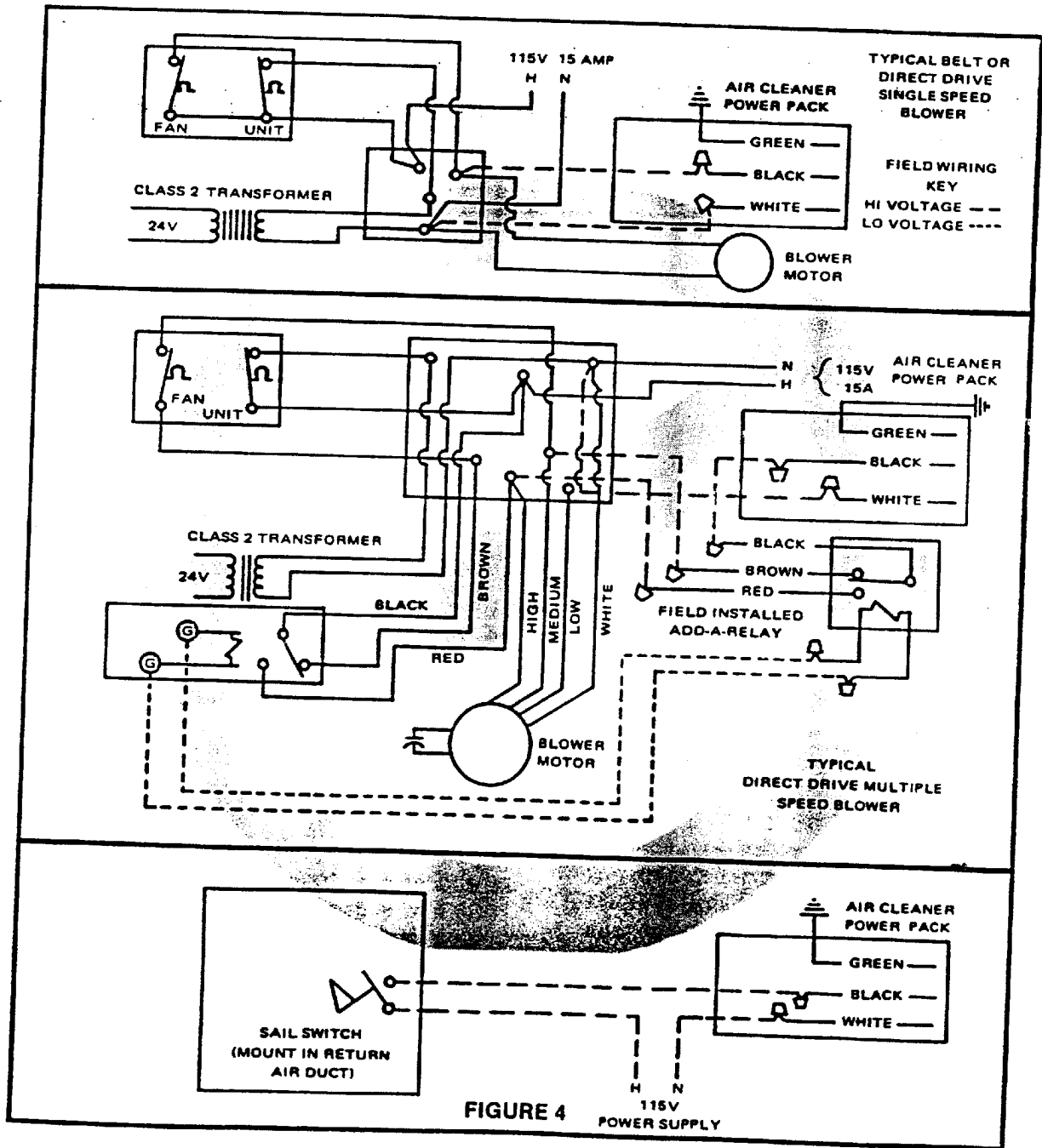

**NOTE:**

The Trion Air Cleaner is equipped with an integral air flow sensor switch which automatically cycles the air cleaner on/off with the central system blower. Therefore, it is not necessary to wire the unit into the blower circuit or utilize an external "sail switch". (Figure 4)

## V. SYSTEM CHECK OUT

After installing the unit, move the On/Off switch to the "ON" position. (Be sure system blower is "ON".)

- A. Both the input (120 VAC) indicating light (green) and the output voltage indicating light (red) should now be on.
  1. Input voltage indicating light (green) shows unit has power.
  2. Output voltage indicating light (red) shows high voltage output to collecting cells.
- B. Check to see if indicating lights go out under the following conditions:
  1. When system blower is off. If not, check continuity of air flow sensor.
  2. When the power switch is in the off position.
  3. When access door is removed.
- C. Refer to Quick Reference Trouble Chart (Page 12) if detailed troubleshooting is required.
- D. See that owner/operator is provided with the owner's manual and the equipment warranty.

## VI. TROUBLESHOOTING

The following instructions are for use by qualified personnel:

**WARNING: THE FOLLOWING PROCEDURES WILL EXPOSE HAZARDOUS LIVE PARTS. DISCONNECT POWER BEFORE PROCEEDING.**

### Recommended Service Tools

- Test light, 120/240 VAC Neon.
- Screw Driver, 8" common with insulated handle.
- Needle nose pliers.
- Ohmmeter, 10,000 (plus) OHM Range.
- Kilovolt meter, 10,000 (Plus) KVDC Positive Polarity Range.

### A. INDICATION OF ELECTRICAL TROUBLE

The output indicating light is wired into the circuit so that it will monitor both the primary and secondary circuits. (Electrically, the ionizing-collecting cell is a component in the secondary circuit.)

When the unit is in normal state of operation, system fan running, access door in place, control switch in the "ON" position, and the output indicating light goes "dim", there is an electrical problem. The problem is a shorted secondary. Although the failure of the output indicating light itself should not be overlooked, this

condition is unusual and rather remote. The light is a L.E.D. and is very reliable.

### B. ISOLATING ELECTRICAL TROUBLE TO MAJOR COMPONENTS

When the unit is in normal state of operation and the output indicating light goes "dim", the trouble can be readily isolated to either the ionizing-collecting cells or power pack. Turn the unit "OFF", remove both ionizing-collecting cells, close the access panel and turn unit "ON". If the light remains "dim" with the cells removed, the trouble is in the power supply or in the primary circuit to the power supply.

If output indicating light is "ON" - trouble is in the cells.

### C. ELECTRICAL TROUBLES & THEIR CORRECTIONS

#### CAUTION:

- EXERCISE THE USUAL PRECAUTIONS WHEN WORKING WITH HIGH VOLTAGE.
- WHEN THE CIRCUIT HAS BEEN DE-ENERGIZED, ALWAYS DISCHARGE ANY RESIDUAL CURRENT IN THE SECONDARY WITH AN INSULATED HANDLE SCREWDRIVER.
- ALWAYS GROUND POWER SUPPLY AND IONIZING-COLLECTING CELL WHEN BENCH TESTING.

There are two areas in which the majority of service problems originate:

- \* The Ionizing-Collecting Cell
- \* The Power Supply

The cell, which is removed from the unit periodically to wash away the collected dirt, is more susceptible to physical damage through handling, than the power supply. The cell, also contains one component, the ionizing wires, which due to their function, have to be designed with a minimum of structural support and therefore susceptible to some expected breakage.

The power supply, like other electrical items exposed to "high voltage" is susceptible to the usual stresses.

Trouble related to either of these two items, is readily shown by the OUTPUT indicating light and can be easily and quickly isolated to one, or the other, by a simple procedure.

### 1. POWER SUPPLY CHECK

Use DC High Volt Meter.

Take reading with the high voltage meter at cell contact point. Should range 8.5 + 10% KV or higher (without cell connected).

If voltage is above 8.5 + 10% KV, the problem is in the cell (see Figure 6, page 7.)

ected), the problem is in the power supply.

Proceed as follows:

- a. Remove power pack from the unit.
- b. Check for loose wires; if loose wire is found, reconnect.
- c. If defective power supply is indicated, replace.

OUTPUT: This is a high frequency solid state circuit designed for electronic air cleaners with high performance reliability.

- 3.2 milliamps on MAX 4 2000
- 2.5 MA on the MAX 4 1400 and Trim-T
- 6.8 + .6 KVDC (with cell connected)
- 8.8 + .8 KVDC (without cell connected)

## 2. PRIMARY CIRCUIT BREAKER

If there is supply line voltage at the service connections and no input voltage to the power supply, the outage can be located by checking operation of the

safety switch and control switch as well as the interconnecting wiring, with a test light. Refer to circuit diagram, Figure 5. If there is power to the line side of either switch, and no power on the load side when the switch is closed, the switch is defective and should be replaced.

## 3. IONIZING-COLLECTING CELL CHECK

The cell is electrically energized through a contact terminal located at the top center of a cell. The ionizing wires and every other collector plate are electrically charged while each interleaving plate is grounded.

If the space between the charged and ground components is bridged with conductive or semi-conductive material, a short circuit develops. The bridging or short may be caused by damaged components or foreign material lodged between or on the components.

Most troubles in the cell can be visually detected.

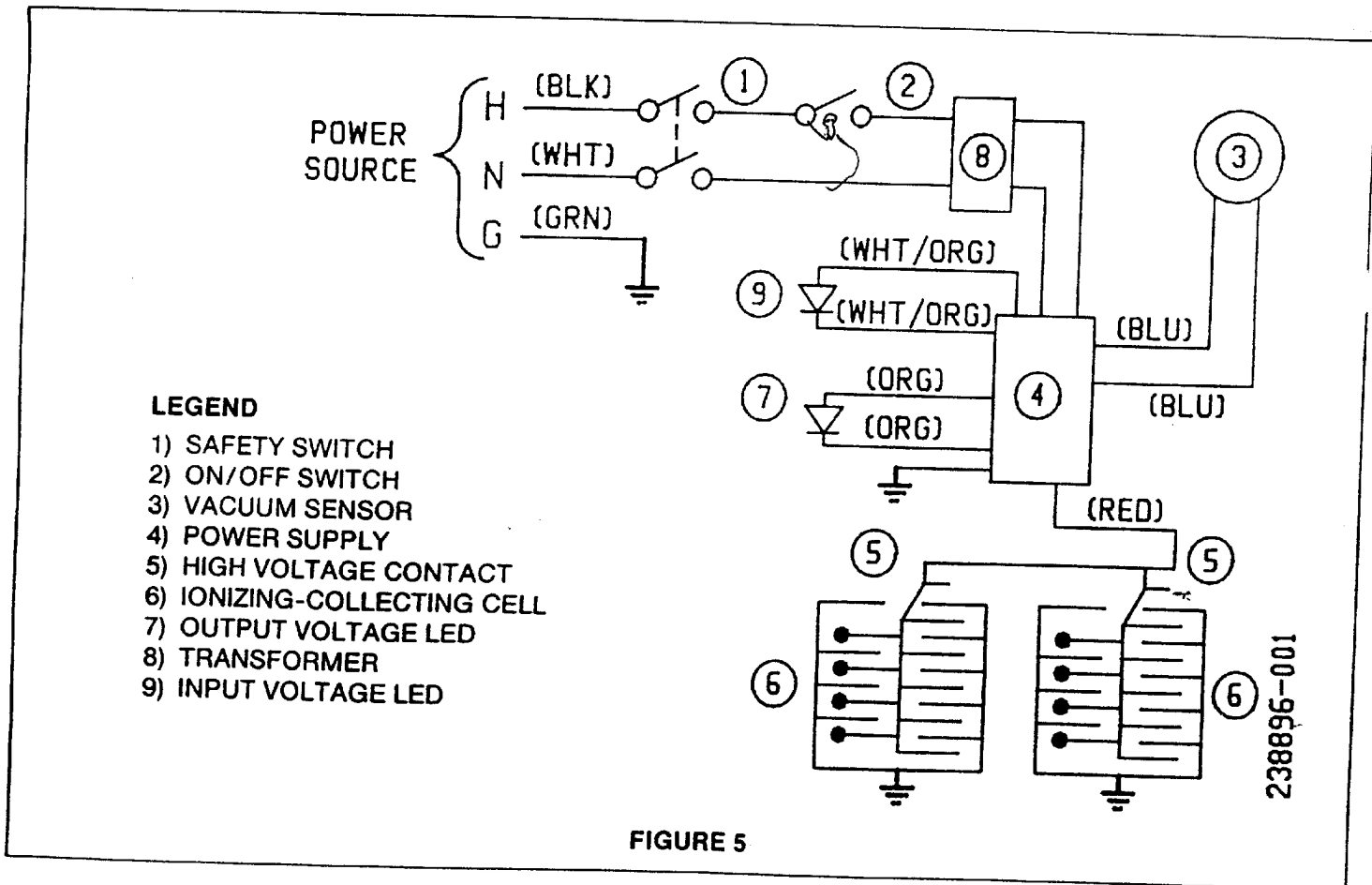

FIGURE 5

CAUSES	CORRECTIONS	CAUSES	CORRECTIONS
Loose ionizing wire(s)	Repair or replace	Excessive dirt build-up	Wash
Excessively dirty cell components	Clean	Large pieces of foreign matter lodged between plates	Remove
Damaged (bent) plates	Straighten or replace	Very dirty insulators	Clean
Defective or loose high voltage lead or contact assembly	Repair or replace	Broken ionizing wires	Remove all pieces of broken wires and replace
Improper ground	Check ground and correct if necessary	Excessively bent or misaligned components due to mishandling	Straighten or replace
		Externally broken or cracked insulators	Replace

FIGURE 6 - IONIZING-COLLECTING CELL CHECKOUT PROCEDURE

D. OTHER FACTS YOU SHOULD KNOW

1. Arcing Noise

When an arcing noise is noted, it is usually located in the DC high voltage circuit. The ionizing-collecting cell is part of this circuit and normally the trouble will be found to be in the cell. The noise is caused by high voltage arcing to ground.

An occasional arcing noise is normal and inherent in all precipitators. These occasional arcs are caused by large particles of dirt in the air such as a cigarette ash, insect, etc. Constant or repeated intermittent arcing must be corrected.

2. HISSING NOISE

A hissing noise (or frying sound) usually stems from a loose high voltage connection or from an improper ground. The reduction in the designed spacing usually is caused by bends or deformities in the cell from mishandling.

Check for:

CAUSES	CORRECTIONS
Damaged (bent) plates of ionizer	Straighten or replace
Loose ionizing wires	Repair or replace
Defective high voltage contact assembly	Repair or replace
Dirty cell or large piece of foreign material between plates	Clean
Poor connection between cell and contact assembly	Repair
Loose high voltage wiring	Repair
Improper ground	Check and correct if necessary

3. HUMMING NOISE

The ionizing wires have a normal tendency to vibrate when charged. On some occasions, when atmospheric conditions are just right and the humidity is exceptionally low, the vibration is aggravated to the point where an audible hum can be noted. It is usually more in the northern sections of the country during the winter months. This condition can be further aggravated if the ionizing-collecting cell is very dirty. The condition is self-correcting when the relative humidity is increased or can be alleviated by washing the cell.

4. RADIO AND/OR TELEVISION INTERFERENCE

This trouble is not common but when occurring is usually due to either a continuous high voltage "leak or discharge", or from the absence of a good common electrical ground. Refer to checks listed under 1. Arcing Noise and 2. Hissing Noise.

5. WHITE DUST

One of the most difficult service calls to handle is the complaint of the presence of white dust. The majority of these complaints are from residential users. In many instances, the statement is made, "We have more dust now than we ever had". These service calls are difficult because the limitations of the installation must be explained.

White dust actually can be described as "clean dirt". Where it is noticed, an examination will show the user that it is largely lint. It is most noticeable on dark furniture, and is usually found in homes containing new furnishings such as carpeting, drapes, etc., which give off more lint than such items that have been used and cleaned for some time. The amount of lint generated is increased by activity in the air, especially by children, pets and heavy house traffic.

Visible lint particles, like cigarette ashes, are heavy as compared to the extremely small, individual dirt particles which make up cigarette smoke. Their weight causes the lint particles to "fall out" on furniture, floors, etc., just as cigarette ashes fall to the floor while cigarette smoke particles remain suspended in the air. Dirt particles, such as heavy pieces of lint or ash, which do not remain airborne, never reach the electronic air cleaner and the unit cannot remove these air particles.

Fortunately, the black, greasy dirt particles with the damaging staining power are light in weight, remain in the air stream, and do reach the electronic air cleaner. It is their removal from the air that keeps the lint clean, and therefore, more visible.

There is no question that the electronic air cleaner is capable of collecting lint in addition to other atmospheric contaminants. This is easily confirmed by examining the air entering side of the ionizing-collecting cell before it is washed. You will note that along with the black, greasy dirt collected, there are lint particles that did stay airborne long enough to reach the electronic air cleaner.

Lint from new furnishings will decrease with wear. The length of time depends on the amount and type of fabric in the furnishings and the air circulation. In some areas, a bedroom for example, a lint condition may always remain.

Normally, continuous fan operation (24 hours a day) will minimize this problem. If this cannot be accomplished, the controls should be set as near continuous fan operation as possible. In some instances the use of a two speed fan motor is advantageous.

Cold air returns should not be restricted in any manner, particularly from rooms in which lint is prevalent. If the returns in these rooms are blocked, the return air will seek another, longer path. In traveling a greater distance, lint fallout is increased.

Actually, the presence of large, clean lint particles is further proof that the air cleaner is doing its superior air cleaning job. Electronic air cleaners are dependent on the movement of air currents to bring the dirt particles to the unit for their removal. Weighty, non-airborne particles such as cigarette ashes weigh too much to remain in the air currents while other particles, such as cigarette smoke, remain suspended and are carried to the electronic air cleaner for removal.

## 6. OZONE

Under normal operating conditions all electrostatic air cleaners produce minute quantities of ozone as an incidental by-product, as do televisions and other electrical appliances. The design of the unit has been tested and is far below the published permissible limits. The level of detection (when it is noticed) varies from individual to individual, some being more susceptible than others.

Usually a new unit will produce more ozone than one that has been in operation for several weeks. This is due to the normal amount of sharp corners or manufacturing burrs on the ionizing-collecting cell. The voltage working on these areas however, tends to round them-off, thereby they are self-correcting.

An ionizing-collecting cell that has been damaged, where the designed spacing between electrically charged and ground components has been decreased, may also produce an abnormal amount of ozone.

If there appears to be excess ozone, check for:

### CAUSES

Damaged (bent) plates  
Loose ionizing wires  
Dirty cell  
Loose high voltage connections  
Unit "ON" when system fan is not running

### CORRECTIONS

Straighten or replace  
Repair or replace  
Clean  
Repair or replace  
Set fan for continuous operation or wire so unit will operate only when system fan is running.

# Maintenance

## Washing Cell and Pre-Filter

Regular washing is necessary to insure proper performance. A thorough washing once every two months will be adequate for most installations. More frequent washings (once a month) may be necessary on some installations (new homes for example) where there is new carpeting, plaster dust, or there is above normal cigarette smoke, etc.

### 1. To remove cell(s) and pre-filter

- Push "Air Cleaner" switch to "OFF". Wait 15 seconds. Open access door.
- Carefully remove cells and pre-filter and set aside.
- Avoid damage to cell plates and ionizing wires.

### 2. To wash in a tub

- Place enough hot water in a utility tub to cover the cell.
- Dissolve 2 to 4 oz. of automatic dishwasher detergent (not laundry detergent) in the water.

### 3. Soaking

- Lay cell on its side in the container and allow to soak for 30 minutes. Repeat with second cell.
- Then "slosh" cell up and down in the solution until it appears clean. Remove cell from the container.
- Next "slosh" the pre-filter up and down in the solution until it appears clean. Drain out dirty water.

### 4. Rinsing

- Hold cell upright in container.
- With a hose, rinse with warm water.
- Hose should be held about 10-in. from cell plates and at a slight angle for better cleaning results. Rinse both sides until water runs clear.
- Thoroughly rinse the cell frame along the edges to dislodge any trapped dirt or lint. Carefully wipe a damp cloth along the ionizing wires.
- Stand cells and pre-filter up to drain. Wait about two hours to dry.

### 5. To wash in dishwasher

- Cells and pre-filter may be washed together or one at a time in an automatic dishwasher if they can fit without damaging the ionizing wires on the cells.
- Use normal amount of automatic dishwasher detergent (powder form).
- Repeat washing if necessary.

### 6. To replace cell

- Replace pre-filter and cells in cabinet. Check that arrow on cells points in same direction as air flows through the duct. (If you have to force it pass guide screw on bottom, it is probably in a wrong position.)
- Reposition access door (engage tips on lower edge of door into slots in cabinet). Carefully close door.
- Turn air cleaner switch to "ON".

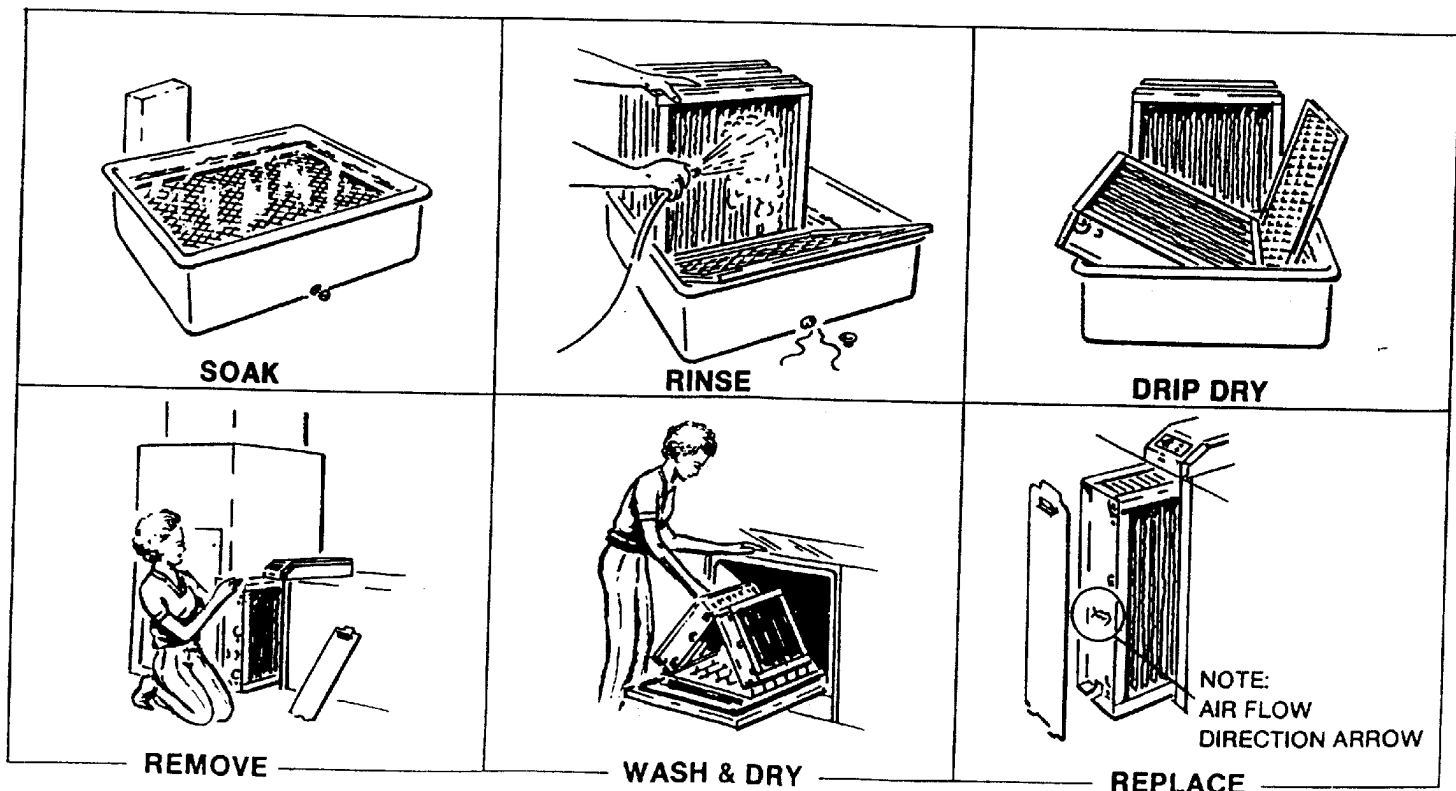

# PARTS LIST

16" x 25"

16" x 25"

20" x 25"

Ref. No.	Trim-T Part No.	MAX 4 1400 Part No.	MAX 4 2000 Part No.	Part Description
1	334370-005	334370-005	334370-005	Power Pack Cover
2	338749-401B	338749-401B	338749-401B	High Frequency Power Supply
3	<del>438881-002</del> 441729-012	438881-002	<del>438881-001</del>	Power Pack Assembly
4	235500-001	235500-001	235500-001	Mini Switch Air Flow Sensor
5	138586-001	138586-001	138586-001	On/Off Switch
6	133548-001	133548-001	133548-001	LED Mounting Clip
7	134516-007	134516-007	134516-007	Input Voltage LED Assembly (Green)
8	134516-006	134516-006	134516-006	Output Voltage LED Assembly (Red)
9	132311-001	132311-001	132311-001	Pushbutton Switch (Double Pole)
10	132122-001	132122-001	132122-001	Pushbutton Cap (On Safety Switch)
11	338751-002	338892-002	338892-001	Cabinet Assembly
12	123324-008	123324-005	123324-004	Pre-Filter
13	422167-503	<del>422085-501</del>	<del>422086-501</del>	Cell, Ionizing-Collecting
14	220111-021	220111-020	220111-029	Ionizing Wire Assembly
15	135104-001	135104-001	135104-001	Handle
16	338906-001	338905-001	338904-001	Front Panel Door Assembly
17	234458-005	234458-005	234458-005	Front Contact Board Assembly
18	234458-002	234458-002	234458-002	Rear Contact Board Assembly
19	227833-003	227833-003	227833-004	Charcoal Filter (Optional) (Not Shown)
20	239071-001	239071-001	239071-001	Step Down Transformer 120 to 24 Volts AC
21	239071-002	239071-002	239071-002	Step Down Transformer 240 to 24 Volts AC
22	138885-001	138885-001	138885-001	Grounding Clip

441729-101

441730-102

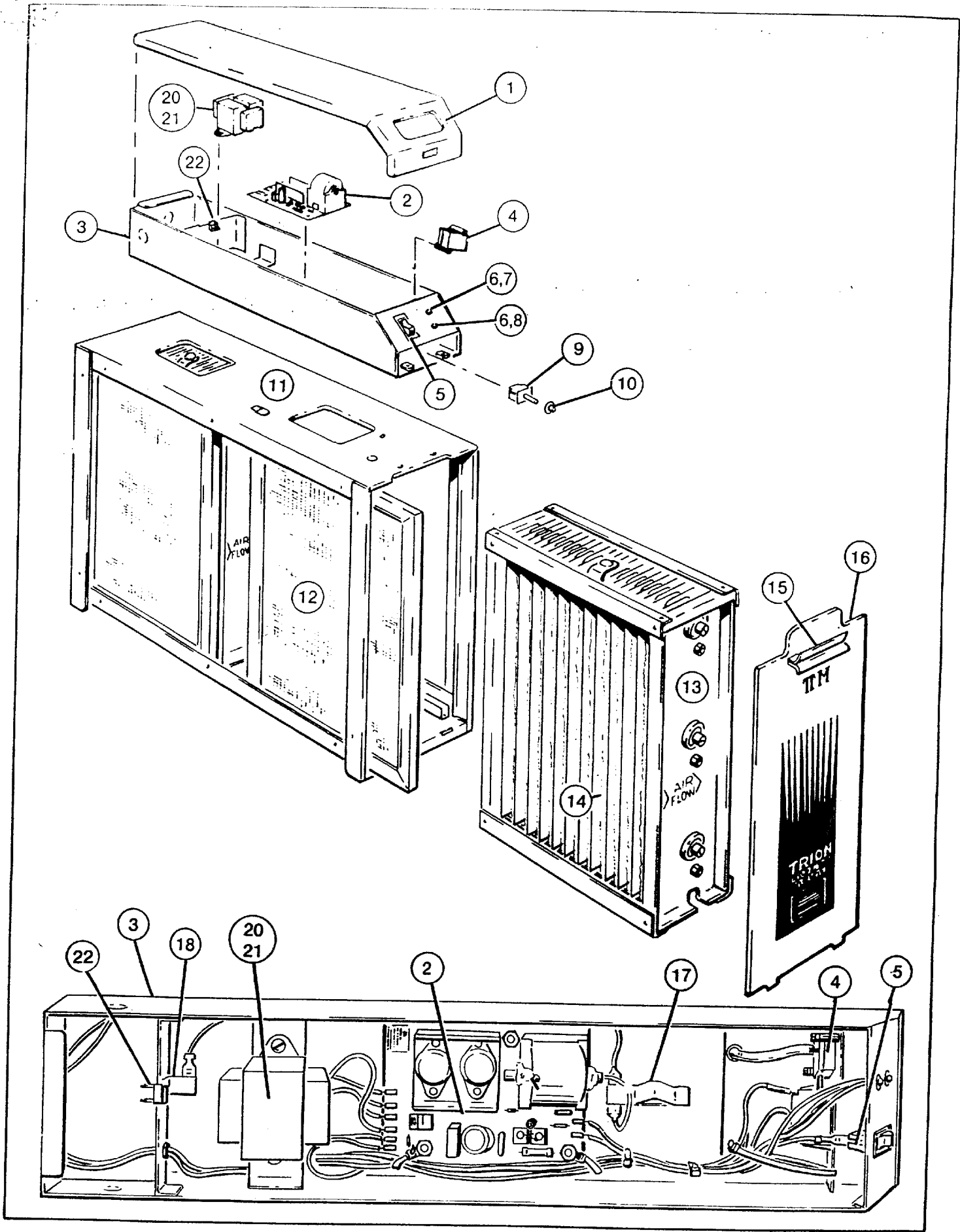

## IX. QUICK REFERENCE TROUBLE CHART

Condition or Symptom	Trouble Description	Probable Location	Possible Cause	Correction
Input Voltage LED (Green) Out	Open Primary Circuit	Primary Wiring	No power from service connection to power supply Blower not on	Obtain power Energize blower
		On/Off switch	Loose wiring Defective wiring	Repair Replace
	Light out but unit working	Power Indicating Light	Defective Light	Replace
Output Voltage LED (Red) Dim	Short Circuit	Power Supply	Defective Power Supply	Replace
		Cell	Broken Ionizing Wire	Remove & replace
			Excessive Dirt	Wash
			Object between plates	Remove
			Damaged (bent) plates	Straighten or replace
			Damaged (bent) ionizer	Straighten or replace
Broken insulator	Replace			
Cracking Noise	Objectionable Noise	Cell	Loose Ionizing Wire	Replace
			Dirty Cell	Wash
			Damaged (bent) plates	Straighten or replace
			Damaged (bent) ionizer	Straighten or replace
Loud Hissing Noise	Objectionable Noise	Cell Hi-Voltage	Dirty Cell	Wash
			Loose Hi-Voltage Connection	Correct
			Insufficient Ground	Correct
Radio and/or TV Interference	Objectionable Noise	Cell Hi-Voltage Connection	Improper Ground	Correct
			Loose Hi-Voltage Connection	Correct
Odor of Ozone	Objectionable Noise		See page 8	