

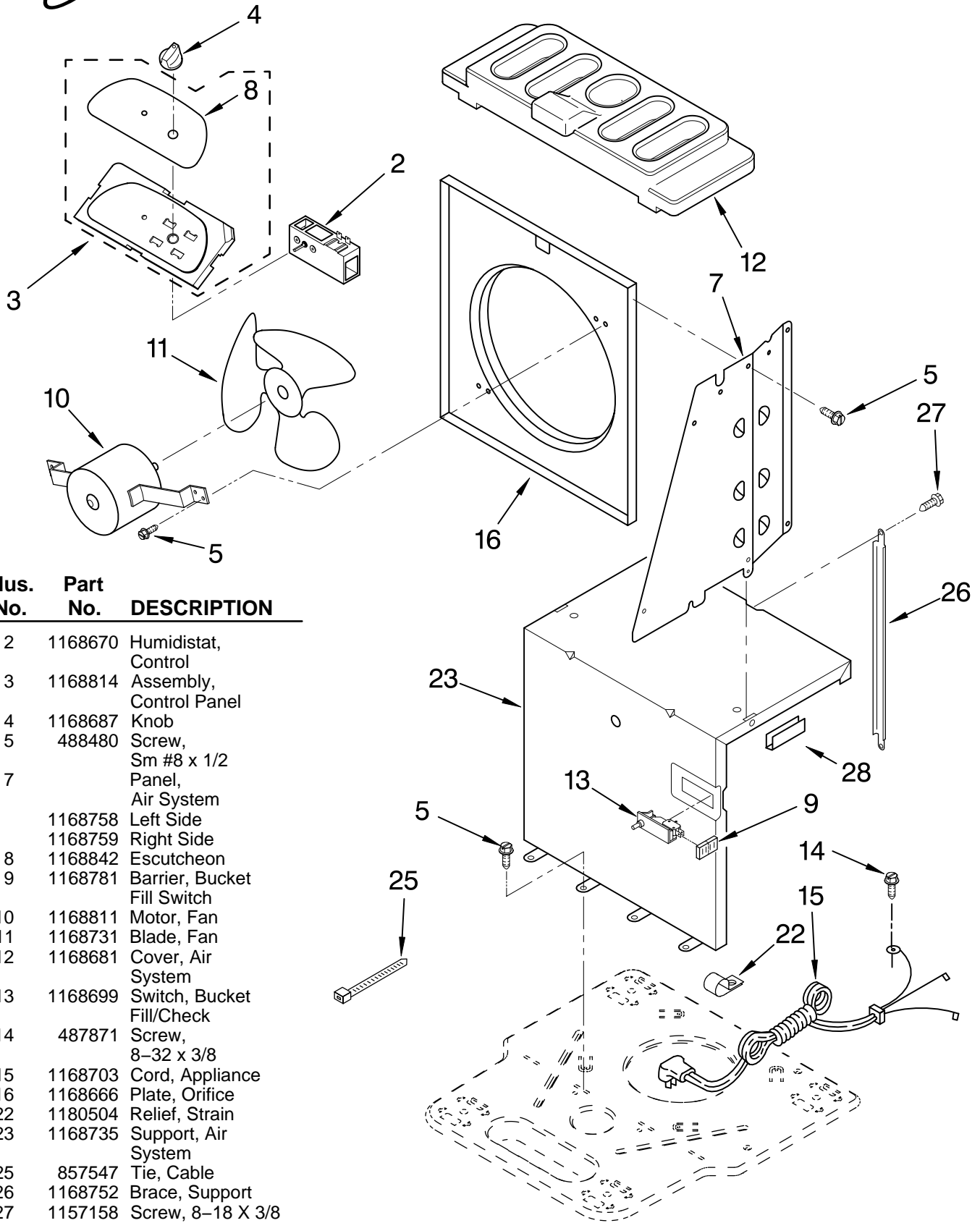

# AIR FLOW AND CONTROL PARTS

For Model: AD025SG0

DEHUMIDIFIER



Illus. No.	Part No.	DESCRIPTION
2	1168670	Humidstat, Control
3	1168814	Assembly, Control Panel
4	1168687	Knob
5	488480	Screw, Sm #8 x 1/2
7		Panel, Air System
	1168758	Left Side
	1168759	Right Side
8	1168842	Escutcheon
9	1168781	Barrier, Bucket Fill Switch
10	1168811	Motor, Fan
11	1168731	Blade, Fan
12	1168681	Cover, Air System
13	1168699	Switch, Bucket Fill/Check
14	487871	Screw, 8-32 x 3/8
15	1168703	Cord, Appliance
16	1168666	Plate, Orifice
22	1180504	Relief, Strain
23	1168735	Support, Air System
25	857547	Tie, Cable
26	1168752	Brace, Support
27	1157158	Screw, 8-18 X 3/8
28	1180634	Edge Guard

FOR ORDERING INFORMATION REFER TO PARTS PRICE LIST

# UNIT PARTS

For Model: AD025SG0

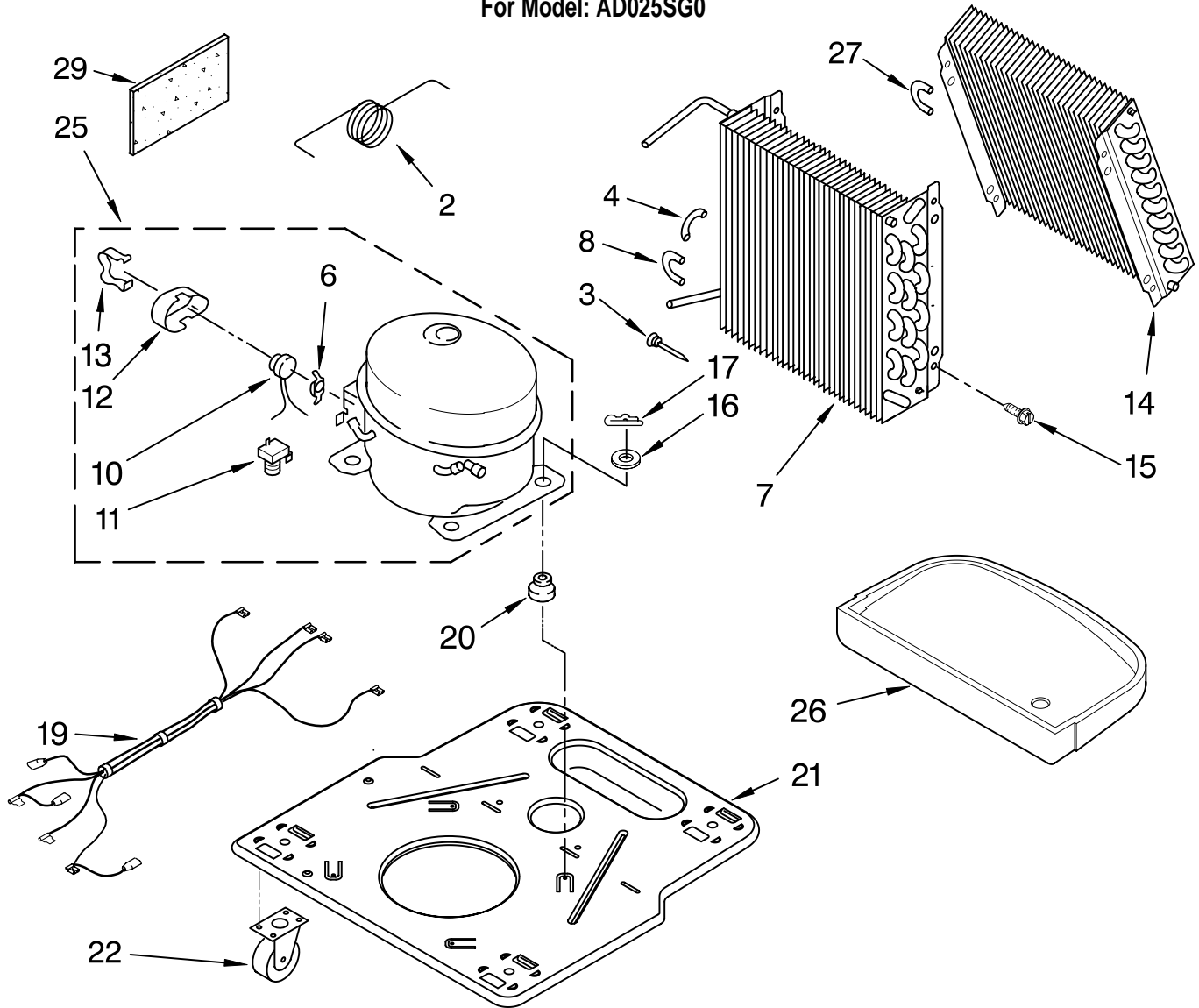

Illus. No.	Part No.	DESCRIPTION
2	1172076	Tube, Restrictor (Length 36.00")
3	1162526	Strainer
4	1169762	Bend, Return (2)
6	950061	Spring, Overload
7	1181854	Condenser
8	708531	Bend, Return (12)
10	1172077	Overload, Protector
11	950058	Relay, Start

Illus. No.	Part No.	DESCRIPTION
12	950055	Cover, Terminal
13	950056	Retainer, Cover
14	1168726	Evaporator
15	488480	Screw, 8 x 1/2 (4)
16	680975	Washer
17	24364001	Clip, Compressor
19	1168810	Harness, Wire
20	1168722	Grommet (4)
21	1168654	Base
22	1164241	Caster (4)

Illus. No.	Part No.	DESCRIPTION
25	1164773	Compressor, (Complete Assembly)
26	1168761	Pan, Drain
27	854624	Bend, Return (9)
29	1162650	Insulation (Restrictor Tube)

## REFRIGERANT CHARGE

6.75 oz.

**Production Compressor Requires Production Electrical Components.**

**Service Compressor Requires Service Electrical Components.**

**For Further Information, Refer to Filmcard 19.1.**

FOR ORDERING INFORMATION REFER TO PARTS PRICE LIST

# CABINET PARTS

For Model: AD025SG0

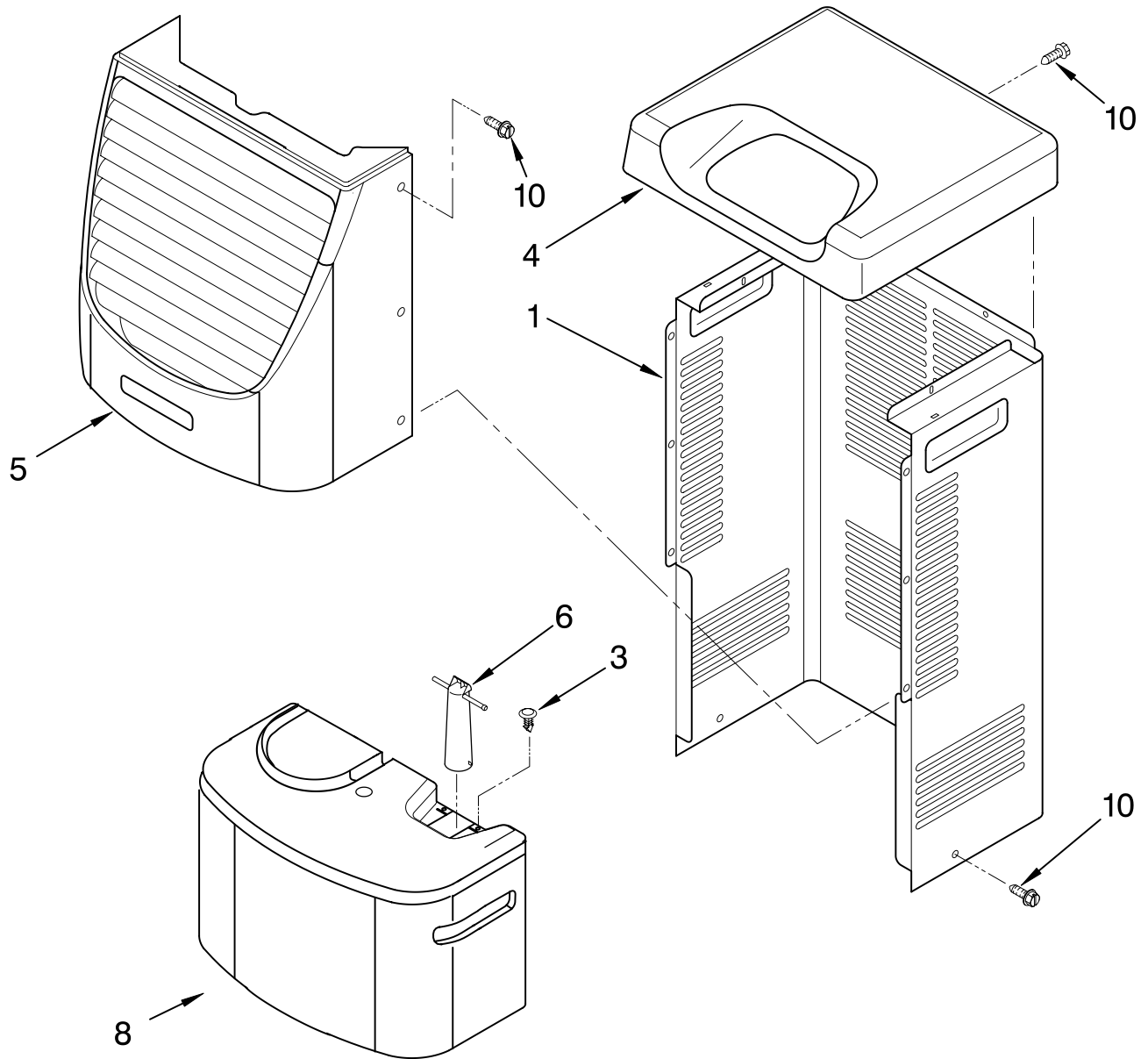

Illus. No.	Part No.	DESCRIPTION
1	1168667	Cabinet
3	1168762	Clip, Float
4	1168652	Cover, Top
5	1182061	Cover, Front
6	1172075	Float
8	1172079	Bucket, Condensate
10	1168744	Screw

Illus. No.	Part No.	DESCRIPTION
Following Parts Not Illustrated and Optional Parts Not Included		
	484310	Epoxy, Tube (Aluminum Repair)
	505168	Tape, No Drip Valve, Access
	978025	1/4" Tube O.D.
	978026	5/16" Tube O.D.
	978027	3/8" Tube O.D.

Illus. No.	Part No.	DESCRIPTION
	978028	1/2" Tube O.D.
	978029	5/8" Tube O.D.
	978030	3/4" Tube O.D.
	978865	Seal, Ring Access Valve (20 Pack)
	LIT1168823	Wiring Diagram
	LIT1182182	Use and Care Guide

FOR ORDERING INFORMATION REFER TO PARTS PRICE LIST