

Honeywell

READ AND SAVE THESE INSTRUCTIONS

HE420A Steam Power Humidifier

OWNER'S GUIDE



69-1112-2

WELCOME...

to the comfortable world of humidified air. With your Honeywell humidifier you will notice a decrease in dry skin, scratchy throats and irritated nasal passages that aggravate allergies and asthma. You've also taken the first step to stopping the "zapping" created by walking on your carpet and touching your TV, computer, metal door knob or your pet. You can even put away your glue bottle because your furniture and woodwork will stop drying out. Congratulations! You have just made a great investment in your home comfort.

TABLE OF CONTENTS

Operating Your Humidifier	3
How Your Humidifier Works	4
Maintaining Your Humidifier	4
Cleaning Your Humidifier	5
Checking Your Humidifier Operation	7
Troubleshooting	7
Warranty	8

OPERATING YOUR HUMIDIFIER

The HE420A Honeywell Humidifier is controlled by an Automatic Humidity Control. The Automatic Humidity Control is mounted in the return air duct where it can be exposed to the air stream of the return air and is designed to automatically adjust the humidity level based on indoor temperature and humidity, inferred or measured outdoor temperature, and the dial setting. The control allows for variations in furnace size, window insulation and average daily climate temperature.

The Automatic Humidity Control requires an initial adjustment period. Set the frost factor dial on 5 and use the following table to adjust the frost factor—only one setting at a time—increasing the dial setting if you feel you need more humidity, or reducing the setting if you see moisture on the inside of your windows. For more precise humidity adjustment, set the frost factor between dial settings. Allow two days for the humidity level to subside before making further adjustments. Once you have tuned in the proper setting, you should never have to adjust it again. The control takes over and makes any future adjustments caused by varying outdoor temperatures, thus reducing moisture buildup on windows while maintaining the optimal humidity level.

Humidity Level	Recommended Adjustment
Insufficient humidity	Increase the frost factor dial by one setting.
Condensation on windows	Decrease the frost factor dial by one setting.

The Automatic Humidity Control can also be set for manual operation. Once the control is installed in the cold air return and internally set to MANUAL, turn the dial to the expected outdoor temperature. The corresponding optimal humidity level has been calibrated for you. For example, by setting the dial to an anticipated 20°F, the control automatically maintains the indoor relative humidity in the safe, comfortable 35% range (see table below).

Outside Temperature	Recommended RH
+40°F	45%
+30°F	40%
+20°F	35%
+10°F	30%
0°F	25%
-10°F	20%
-20°F	15%

HOW YOUR HUMIDIFIER WORKS

Your Honeywell humidifier uses the principle that hot water creates moist air and as the moist air circulates, the relative humidity rises. Your humidity control monitors the relative humidity and activates the humidifier accordingly.

When the humidity control calls for humidity, the humidifier underwater heater starts heating the water in the humidifier reservoir. When the water is warm enough, the humidifier activates a relay that turns on the furnace fan. The warm dry air from the furnace picks up the moist air and circulates it through the home. The fan continues to circulate the air until the water cools down and then turns off the fan.

Humidified air feels warmer and more comfortable so you may be able to lower your thermostat heating setpoint and save money on your heating fuel bills. The end result is that your humidifier gives you a comfortable environment that is also energy efficient.

MAINTAINING YOUR HUMIDIFIER

A regular maintenance program prolongs the life of your humidifier and provides a more comfortable home. Frequency of cleaning depends on the condition of your water. You can use either hard or soft water in your humidifier, but hard water mineral deposits are more difficult to clean than soft water deposits.

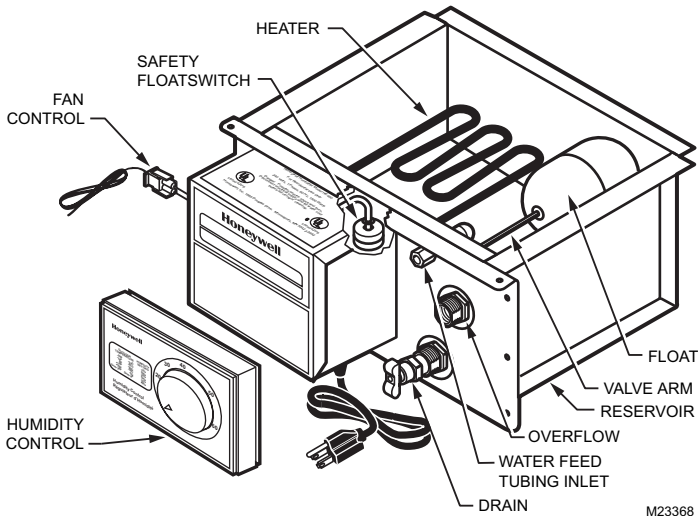

CLEANING YOUR HUMIDIFIER

WARNING

Voltage Hazard.

Can cause electrical shock and equipment damage.

Disconnect power and shut off water supply before installing or servicing.

IMPORTANT

Never oil any part of the humidifier.

Every 1 to 4 Months (Depending on Water Quality)

Use the following procedure to clean your Honeywell humidifier:

1. Unplug the humidifier and fan control.
2. Disconnect the wires from the humidity control external screw terminals.
3. Turn off the water supply.
4. Disconnect the water feed tubing at the float valve.
5. Disconnect the overflow at the humidifier.

IMPORTANT

Allow water to cool before continuing.

6. Press and release the MANUAL button on the Automatic Flushing Timer.
 - Wait 10-30 seconds* until the flushing noise stops, indicating that the flushing cycle is complete.
 - *The number of seconds will vary depending upon how the unit is programmed. (See "Reprogramming Instructions" in the Auto Flushing Timer Installation Instructions)*
 - Repeat Steps A and B until the humidifier is drained.
7. Remove the humidifier from the mounting.
8. Use running tap water to flush loose minerals from the reservoir.
9. Carefully rub minerals off of the float, heater, reservoir walls and safety float switch.

NOTE: Steel wool or other scouring pads can be used on the reservoir walls and other parts.

10. Inspect the valve arm and float for mineral buildup and deterioration.

NOTE: If deterioration is noted, replacement will be necessary.

11. Reset the water level.



CAUTION

Flooding Hazard.

Inadequate support of the float arm can lead to valve seat damage resulting in water leakage.

Support the float arm during adjustment.

- a. Set the humidifier reservoir on a level surface.
- b. Attach the water feed line and allow the unit to fill until the float valve shuts off the incoming flow of water. The water level should be between 2-1/4 in. (57 mm) and 2-1/2 in. (64 mm) deep. If water level is correct, skip to step 12.
- c. Adjust the water level in small increments. Raise the water level by pushing down on the center of the float arm. Lower the water level by pressing the float down with one hand and pulling up on the center of the float arm with the other hand.

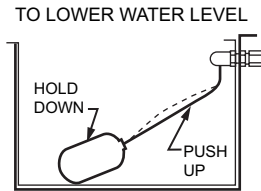
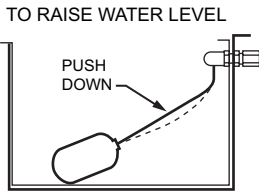

M10581A

- d. Verify the water level by removing enough water to allow the float valve to automatically fill and shut off the water.
12. Remount the humidifier.
 13. Reconnect all plumbing connections.
 14. Reconnect all electrical connections.
 15. Verify the humidifier operation by following the steps in the Checking Your Humidifier Operation section on page 7.

End of Humidification Season

Clean and shut off the humidifier at the end of the heating season. See the Cleaning Your Humidifier section, steps 1 through 10 and step 12, to shut down for the season.

IMPORTANT

Be sure the humidifier power is off and there is no water in the humidifier when you are done.

Vacation

When you leave on vacation, turn off the humidifier water supply and your humidity control. Turn on the humidifier water supply and reset your humidity control when you return.

CHECKING YOUR HUMIDIFIER OPERATION

After winter startup or maintenance, use the following steps to check the humidifier operation:

1. Turn on the humidifier water supply.
2. Be sure the humidifier has power, and plug in the humidifier.
3. Turn the Automatic Humidity Control to the Test setting. The underwater heater starts to heat the reservoir water.

NOTE: If relative humidity is above 45% in the home, or the outdoor temperature is above 50°F, a jumper may need to be placed across the humidistat's OUT terminals to perform this checkout.

4. Check that the furnace blower turns on to circulate the moist air. The blower may take as long as fifteen minutes before it turns on.
5. Reset the Automatic Humidity Control to the desired dial setting.

TROUBLESHOOTING

Problem	What To Look For	What To Do
Low humidity	Humidifier heater is not operating.	<ul style="list-style-type: none"> • Confirm that humidifier is plugged in. • Set the humidistat higher. • Check for low water level. • Reset circuit breaker or check for blown fuse. • Check that the furnace power is on. • Check all external wiring connections. • Check the humidity control setting. • Call a professional heating contractor.
	Rapid air changes. Drafts (cold air is dry and is an added load for the humidifier).	<ul style="list-style-type: none"> • Keep doors and windows closed. • Close fireplace damper when not in use. • Keep exhaust fan running time to a minimum. • Seal around doors and windows.
High humidity	Condensation on walls.	<ul style="list-style-type: none"> • Turn off the humidity control and water until condensation is completely evaporated.
	Heavy condensation on windows.	<ul style="list-style-type: none"> • Turn humidity control down low enough to eliminate condensation caused by moisture from bathing, mopping, cooking, etc. If moisture persists, more ventilation is needed.

WARRANTY

Honeywell warrants this product to be free from defects in the workmanship or materials, under normal use and service, for a period of five (5) years from the date of purchase by the consumer. If, at any time during the warranty period, the product is defective or malfunctions, Honeywell shall repair or replace it (at Honeywell's option) within a reasonable period of time.

If the product is defective,

- (i) return it, with a bill of sale or other dated proof of purchase, to the retailer from which you purchased it, or
- (ii) package it carefully, along with proof of purchase (including date of purchase) and a short description of the malfunction, and mail it, postage prepaid, to the following address:

Honeywell Return Goods
Dock 4 MN10-3860
1885 Douglas Drive
Golden Valley, MN 55422

This warranty does not cover removal or reinstallation costs. This warranty shall not apply if it is shown by Honeywell that the defect or malfunction was caused by damage which occurred while the product was in the possession of a consumer.

Honeywell's sole responsibility shall be to repair or replace the product within the terms stated above. HONEYWELL SHALL NOT BE LIABLE FOR ANY LOSS OR DAMAGE OF ANY KIND, INCLUDING ANY INCIDENTAL OR CONSEQUENTIAL DAMAGES RESULTING, DIRECTLY OR INDIRECTLY, FROM ANY BREACH OF ANY WARRANTY, EXPRESS OR IMPLIED, OR ANY OTHER FAILURE OF THIS PRODUCT. Some states do not allow the exclusion or limitation of incidental or consequential damages, so this limitation may not apply to you.

THIS WARRANTY IS THE ONLY EXPRESS WARRANTY HONEYWELL MAKES ON THIS PRODUCT. THE DURATION OF ANY IMPLIED WARRANTIES, INCLUDING THE WARRANTIES OF MERCHANTABILITY AND FITNESS FOR A PARTICULAR PURPOSE, IS HEREBY LIMITED TO THE FIVE YEAR DURATION OF THIS WARRANTY. Some states do not allow limitations on how long an implied warranty lasts, so the above limitation may not apply to you.

This warranty gives you specific legal rights, and you may have other rights which vary from state to state.

If you have any questions concerning this warranty, please write to Home and Building Control Customer Relations, Honeywell, 1985 Douglas Drive North, Minneapolis, MN 55422. In Canada, write Retail Products ON15-02H, Honeywell Limited/Honeywell Limitée, 35 Dynamic Drive, Scarborough, Ontario M1V 4Z9.

Automation and Control Solutions

Honeywell International Inc. Honeywell Limited-Honeywell Limitée
1885 Douglas Drive North 35 Dynamic Drive
Golden Valley, MN 55422 Scarborough, Ontario M1V 4Z9
yourhome.honeywell.com



Printed in U.S.A. on recycled paper containing at least 10% post-consumer paper fibers.

Honeywell