

This Owner's Manual is provided and hosted by [Appliance Factory Parts](#).



HERRMIDIFIER Trim TX - Black Unit Owner's Manual

[Shop genuine replacement parts for HERRMIDIFIER
Trim TX - Black Unit](#)



[Find Your HERRMIDIFIER Air Cleaner Parts - Select From 27 Models](#)

----- Manual continues below -----

Duct Mount Electronic Air Cleaner

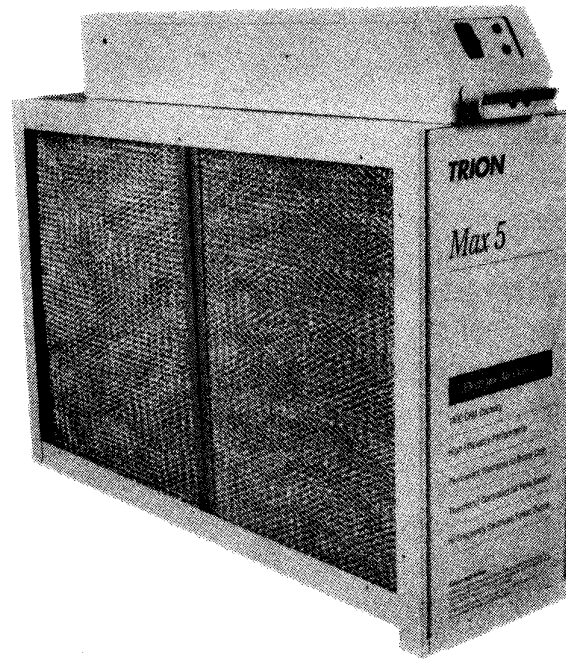

Manual for:

Installation • Operation • Maintenance

Max 5 2000, Max 5 1400, 1400 20 x 20, and Trim TX Models

Units available in 120 or 240 Volt

CAUTION: Read installation instructions and rules carefully for safe operation.
Exercise the usual precautions when working with high voltage.

TRION[®]

This manual provides information for location, installation, operation and service. Before installation and use of the air cleaner, carefully read these instructions to insure maximum benefits from the unit and to avoid needless service costs that can result from improper installation.

I. INTRODUCTION

This electronic air cleaner is technically known as a two-stage electrostatic precipitator. The air cleaner is designed to remove airborne particulates - dust, dirt, smoke, pollen, virus, spores, bacteria, mold - from indoor air

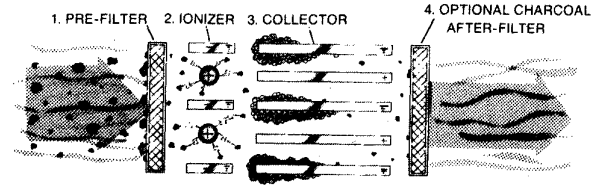

Air movement through the unit is provided by the heating, air conditioning or ventilating system blower. As dirty air enters the air cleaner, the air passes through a metal mesh pre-filter. The pre-filter prevents lint, pet hair and other large particulates from entering the air cleaner by impingement. It is important that these filters be in place to prevent excessive dirt loading of the air cleaner collector cells. These filters extend the time between maintenance of the air cleaner collector cells. This allows the collector cells to provide clean air for a longer period between washing.

The pre-filtered air then passes through a two-stage electronic air cleaner. In the first stage, all airborne particulate, even submicron size, are electrically charged (positive) as they pass through the ionizer. The ionizer field is set up by a corona discharge emanating from the fine, tightly strung wires suspended between two adjacent flat plates. In the second stage, the charged particulate passes into an intense electrical field established between alternately charged and grounded parallel plates. Here the positively charged particulate is attracted to the ground plates and is precipitated out of the air stream.

II. SPECIFICATIONS (Specifications subject to change without notice.)

MODEL	MAX 5 2000 (20 x 25)	MAX 5 1400 (16 x 25)
Electrical Input	120 V, 60 HZ, 1PH* (240 V, 50/60 HZ, 1PH)*	120 V, 60 HZ, 1PH* (240 V, 50/60 HZ, 1PH)*
Max. Rated Capacity	2000 CFM (3400 m ³ /hr.)	1400 CFM (2380 m ³ /hr.)
Max. Pressure Drop	.14 in. w.g. @ 2000 CFM	.11 in. w.g. @ 1400 CFM
Cell Weight	(2) 12lbs. each (5.5 Kg.)	(2) 10lbs. each (4.5 Kg.)
Unit Weight	46 lbs. (20.9 Kg.)	41 lbs. (18.6 Kg.)
Power Consumption	48 watts maximum	40 watts maximum
Electrical Output	3.2 MA @ 6200 VDC	2.5 MA @ 6200 VDC

*Specify 120 or 240 volt when ordering

AIR CLEANER CONSTRUCTION

The air cleaner is easy to install, operate and maintain. Its basic components are the:

CABINET - mounts to existing ductwork; houses the collecting cells and pre-filters

COLLECTING CELLS - collect the dust, dirt and other particulate in the air. They contain the ionizing and collecting sections as described above. The cells must be installed with ionizing wires on the air intake side. A spring contact is located on the top of each cell and must be in position to make contact with the contact board assemblies on the bottom of the Power Supply (Fig 1).

PRE-FILTERS - trap large particulate before it enters the collector cells.

POWER SUPPLY ASSEMBLY - contains the indicating lights, the solid state power supply, electronic air flow sensor, contact boards and electrical controls including On/Off switch and safety interlock switch. It also includes a wiring compartment located at the rear of the power supply assembly.

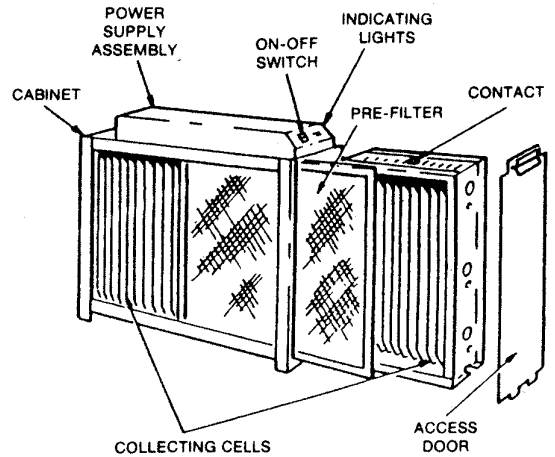

Figure 1

MAX 5 1400 SQ (20 x 20)	TRIM TX (16 x 25)
120 V, 60 HZ, 1PH* (240 V, 50/60 HZ, 1PH)*	120 V, 60 HZ, 1PH* (240 V, 50/60 HZ, 1PH)*
1400 CFM (2380 m ³ /hr.) .07 in. w.g. @ 1400 CFM (2) 9lbs. each (4.1 Kg.) 40 lbs. (18.1 Kg.) 40 watts maximum 2.5 MA @ 6800 VDC	1200 CFM (2040 m ³ /hr.) .07 in. w.g. @ 1200 CFM (2) 6lbs. each (2.7 Kg.) 32 lbs. (14.5 Kg.) 40 watts maximum 2.5 MA @ 6200 VDC

III. PLANNING THE INSTALLATION

*Application

The air cleaners are used in forced air heating cooling and ventilating systems. Because of a built-in electronic air flow sensor the air cleaner operates automatically with the system blower. The air cleaner should be installed in the system so that all the system air is circulated through the air cleaner. The air cleaner will only remove the airborne contaminants delivered to it. Maximum performance is obtained when the system blower is set for continuous operation.

*Installation Requirements

The best location for the air cleaner is in the return air next to the blower compartment. In this location the blower motor and cooling coils will be kept clean.

DO NOT INSTALL THE AIR CLEANER IN THE DISCHARGE AIR DUCT.

Before installing the air cleaner consider the application (See Fig. 7 to 12). If a transition is required refer to section entitled "**Transitions**". The unit must be readily accessible for periodic inspection and cleaning of the pre-filters and electronic cells to maintain maximum efficiency and trouble-free operation.

*Air Conditioning

The air cleaner should be installed upstream of the cooling coil. This will keep the coil clean and reduce air conditioning coil maintenance. Improved cooling efficiency is the result which directly affects energy costs. A clean coil will reduce utility costs. If the air cleaner

is downstream of the cooling coil, condensation will form on the cooled collector plates when the air conditioner cycles. This will allow water droplets to form on the collector plates and cause nuisance arcing. Arcing will reduce air cleaner efficiency and reduce the life of the high voltage power supply.

*Humidifiers

An evaporative humidifier can be mounted upstream of the air cleaner. It is best to install an atomizing humidifier downstream of the air cleaner because hard water salt deposits and water droplets may damage the air cleaner. If an atomizing humidifier must be mounted upstream of the air cleaner:

1. Mount it as far upstream as possible. (Recommend at least 6 feet.)
2. Install a standard disposable furnace filter between the humidifier and the air cleaner to trap water droplets and hard water salts.
3. Clean the air cleaner more frequently to prevent a hard water salt buildup.

*Outdoor Air

When outdoor air is added to the return air duct, sufficient heat should be added to maintain the return air temperature at 40°F(4°C) minimum. Lower temperatures can cause ionizer wire failure.

*Sheet Metal Installation

The electronic air cleaner is adaptable to all new or existing residential forced air furnace and cooling systems.

*Transitions

If the air duct does not fit the air cleaner cabinet opening, gradual transitions are recommended to reduce air turbulence through the air cleaner and maximize efficiency. Not more than 20° (about 4" per running foot) of expansion should be used on each side of the transition fitting (See Fig. 2).

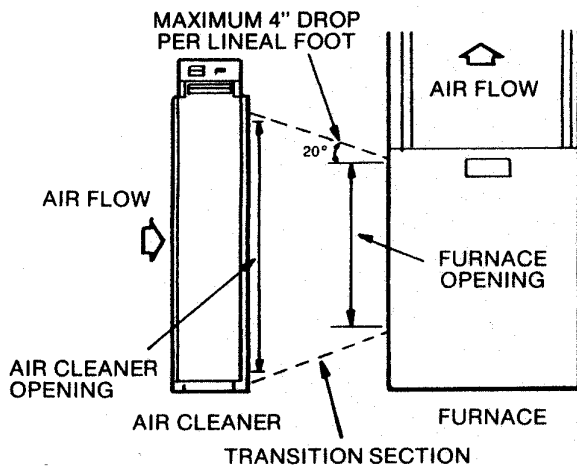

Figure 2

*Turning Vanes

If the air cleaner is installed adjacent to a 90° duct elbow, add turning vanes inside the duct to improve the air distribution across the face of the air cleaner (See Fig. 3).

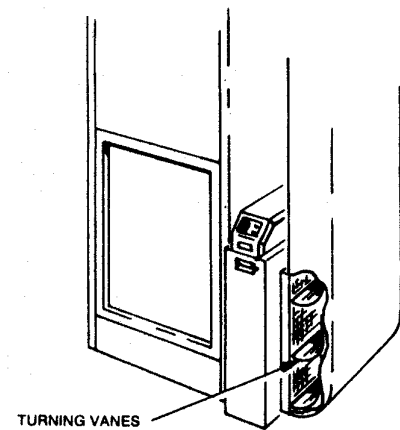
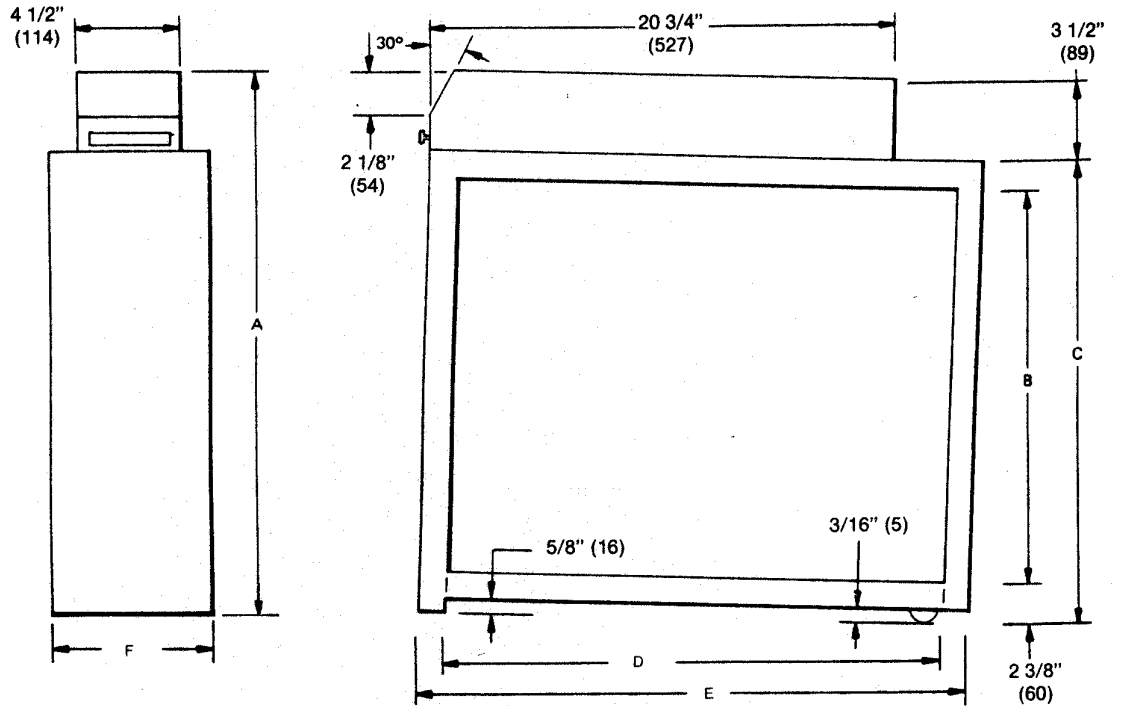

Figure 3

DIMENSIONS



NOTE: All dimensions in parentheses are in mm.

DIMENSIONS

MODEL	"A"		"B"		"C"		"D"		"E"		"F"	
	in./mm	in./mm	in./mm	in./mm	in./mm	in./mm	in./mm	in./mm	in./mm	in./mm	in./mm	
MAX 5 1400	20-1/2	521	13-7/8	352	16-1/4	413	22-1/2	572	25	635	7-1/4	184
MAX 5 1400 SQ 20 x 20	24-1/2	622	17-7/8	454	20-1/4	514	19	483	21-3/8	543	7-1/4	184
MAX 5 2000	24-1/2	622	17-7/8	454	20-1/4	514	22-1/2	572	25	635	7-1/4	184
TRIM TX	20-1/2	521	13-7/8	352	16-1/4	413	22-1/2	572	25	635	5-1/4	133

Figure 4

SELECT LOCATION

Remember to select a location that is readily accessible for periodic inspection and cleaning. Allow a minimum of 18" clearance in front of the access panel (26" for Trim TX) and 12" clearance above the power pack cover plate for component removal and service space. For complete dimensions required refer to Figure 4.

DIRECTION OF AIR FLOW THROUGH THE AIR CLEANER

NOTE: The air cleaner is set up for left to right air flow when facing the access door. For right to left air flow remove the pre-filter(s) and cells from the cabinet. A plastic positioning spacer is located inside the bottom of the cabinet secured to the cabinet using a #6-32 round head Phillips drive thread cutting screw (See Fig 5) to index installation of the cells in the proper position with respect to air flow. Remove the screw and reposition

the spacer in the alternate hole at the bottom of the cabinet. Replace the screw to insure the plastic spacer is not accidentally knocked out of place during normal maintenance. It must be installed in the hole provided closest to the air leaving side of the cabinet. Seal the unused hole with duct tape. Turn cells around, replace in cabinet and replace pre-filters on the air entering side. The directional arrows on the cell end plates must point in the direction of air flow.

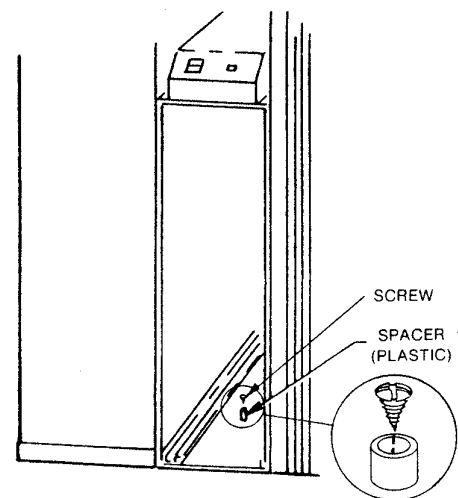

Figure 5

CAUTION: Only a trained, experienced serviceman should install this electronic air cleaner. The power supply should be removed before installation. To remove the power supply, remove the two (2) screws (See Figure 6) in the top front of the cabinet. Remember to keep this hardware for reinstallation of the power supply when the air cleaner installation is complete. A thorough checkout of the unit installation should be completed before unit operation.

HELP LINE

If you have any questions on installation, call:

1-800-33-TRION

IV. INSTALLATION

MECHANICAL

The air cleaner can be in any position, except with the access door facing down. Figures 7-12 show proper air cleaner mounting with a variety of furnace installations.

Prior to installing this product . . .

1. Read rules and instructions carefully for safe operation. Failure to follow them could damage the product or cause a hazardous condition.
2. Check the ratings given on the product to make sure it is suitable for your application.

SELECT LOCATION

3. Remove the old furnace filter and discard.
4. The air cleaner cannot remove existing dirt from the blower and ducts. Clean the area thoroughly before you begin.
5. Remove unit access panel, and slide the pre-filters and ionizing-collecting cells out of the cabinet. Place them safely aside with the warranty registration card.

NOTE: The following is a typical installation of the air cleaner on a highboy furnace (Fig. 9). You may have to alter the installation to fit your application.

6. Locate the cabinet in the cold air return duct so that all of the return air flows through the unit (Fig. 6). If the furnace and air cleaner openings are different,

use a transition (Fig. 2).

7. Mounting holes are provided for duct work attachment (Fig. 6). The .140" holes are sized for #8 sheet metal screws, or 1/8" rivets. If the adjoining ductwork is flanged, install the screws so that the screw heads are inside the cabinet. This will prevent damage to pre-filters and optional charcoal after-filter during removal and installation after cleaning.

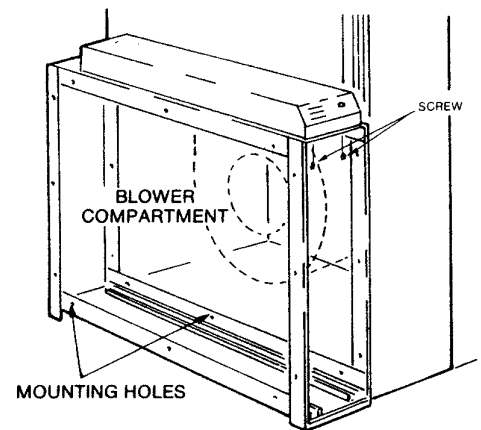

Figure 6

8. After the unit has been secured, seal seams air tight with duct tape or caulking.

ATTENTION: Be extremely careful not to cover the air flow sensor orifice when sealing the air cleaner and duct work. This hole is located on the right hand side (when facing the unit) of the power pack assembly. The hole is 3/16" diameter and is located approximately 3" from the front and 1" from the bottom of the power pack assembly.

The air flow sensor is described further in the service booklet. In applications with minimum air flow, it is helpful to seal any openings on the power pack assembly or cabinet.

NOTE: The only opening required for actuation of the air flow sensor is the 3/16" diameter hole previously described.

9. Refer to Direction of Air Flow on Page 6.
10. Install pre-filters and ionizer-collector cells.
11. Reinstall power supply on top of cabinet.
12. Reinstall cabinet front panel door assembly.

TYPICAL MOUNTING POSITIONS

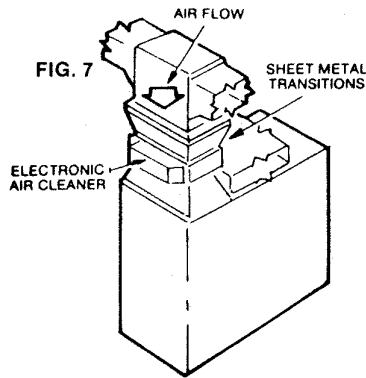

BASEMENT FURNACE (LOWBOY)
Mounted horizontally in return plenum - just above the furnace.

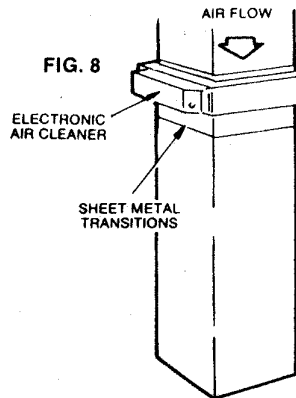

COUNTERFLOW FURNACE
Mounted horizontally in return duct or plenum, just above furnace.

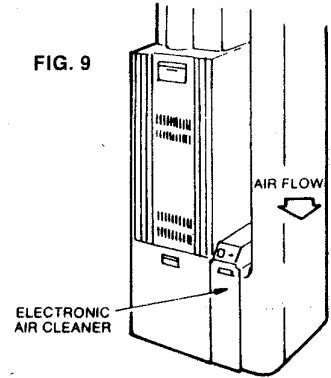

SPACE SAVER FURNACE (HIGHBOY)
Side installation. Cleaner is mounted vertically, where return air enters side inlet of furnace.

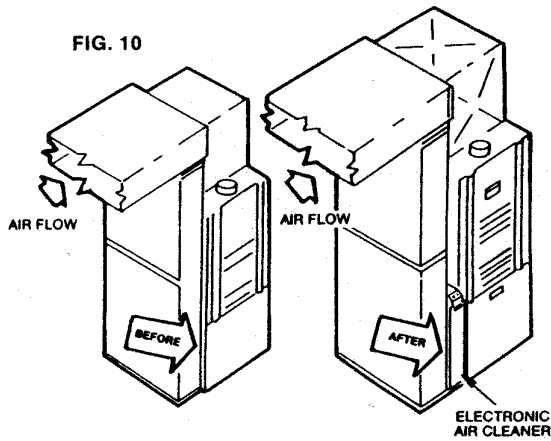

OFFSET INSTALLATION
If there is less than 7-in. for mounting the air cleaner between the duct and the furnace, move the return air drop.

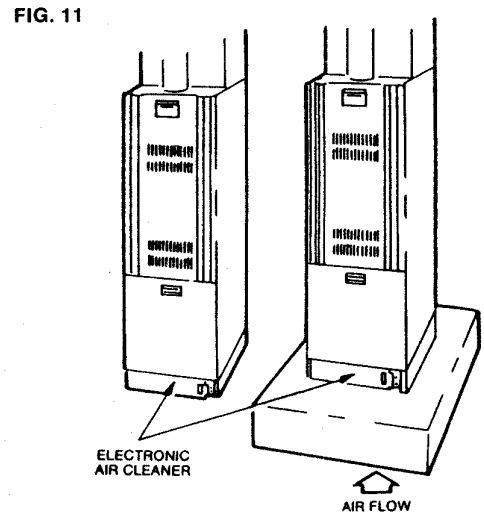

SPACE SAVER (HIGHBOY)
Installation beneath furnace. Cleaner mounts horizontally, where return air enters from below. Raise furnace by installing a suitable wood structure and install air cleaner.

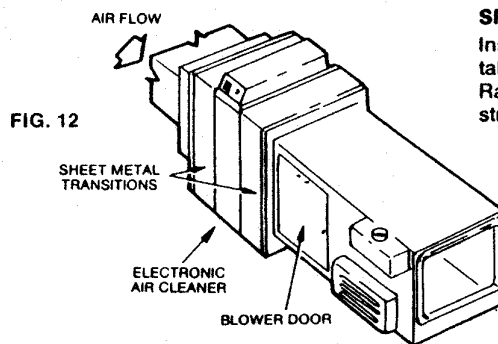

HORIZONTAL FURNACE
Mounted vertically in the return duct as close to furnace as possible.

ELECTRICAL INSTALLATION

Electronic Air Cleaners are simple to wire. The air cleaner is rated at either 120V or 240 VAC and power can be picked up from any convenient source. **It is not necessary to install relays or sail switches to insure air cleaner operation with the blower system.**

This electronic air cleaner has a **BUILT-IN AUTOMATIC AIR FLOW SENSOR**. The location of the air flow sensor is shown in Fig.13.

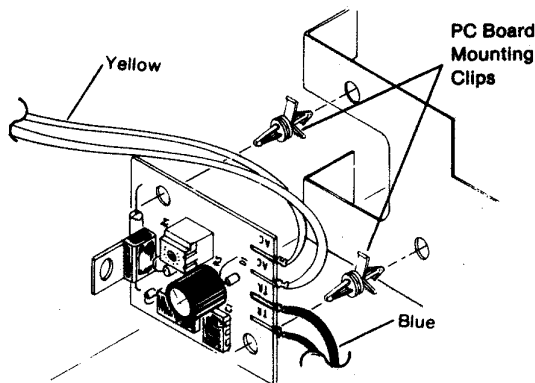

Figure 13

PROCEDURE

1. Remove power pack cover plate.
2. Wire unit to 120 volt, 60 Hertz, 1phase (or 240 volt, 50/60 Hertz, 1phase) supply. A field wiring compartment (with knock out holes) is located at the rear of the power pack assembly (Fig. 14). The electronic air flow sensor will automatically cycle your Electronic Air Cleaner with the blower system. The sensor is activated when the fan is on and air flow is present in the duct. It is pre-set at the factory and needs no adjustment (Fig. 13). Adjustment of the air flow sensor voids the warranty.

CAUTION: Do not wire directly to multiple speed blower motor. Wiring to multiple speed blower motor will damage power supply and void warranty.

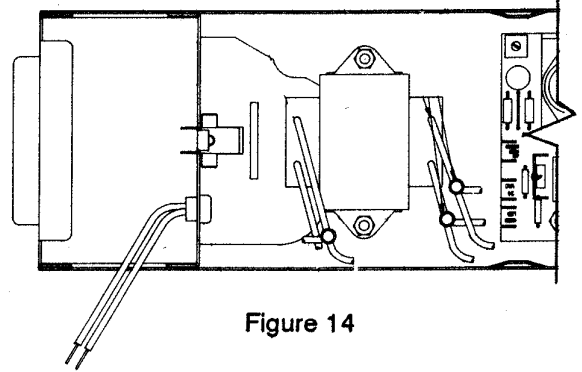

Figure 14

V. SYSTEM CHECKOUT

BE SURE THE SYSTEM BLOWER IS "OFF". After installing the unit, switch the On/Off rocker switch to the "ON" position. **A bright red segment of the rocker switch should be visible.**

1. Both the input indicating light (green) and output voltage light (red) should now be on.
2. Both lights should go out in approximately 30 to 60 seconds. This is the normal time for the electronic air flow sensor to complete its stabilization period.
3. Turn the system blower to the "ON" position. Both lights should illuminate.
4. Check to assure that both lights go out when the cell access panel is removed, when the rocker switch is switched to the "OFF" position, and when the system blower is not running.

NOTE: The air flow sensor must go through its normal stabilization period when power is disconnected from the input to the air cleaner. This includes opening the access door on the cabinet, switching the On/Off rocker switch to the "Off" position and any interruption of input power from the main power source. (Circuit breaker trips, fuse opens, electrical power is interrupted)

CAUTION:
The following instructions are for use by qualified personnel only.

WARNING:
The following procedures will expose hazardous live parts. Disconnect power between checks and proceed carefully

To eliminate the air flow sensor and operate the air cleaner from terminals provided in the furnace/air conditioning system follow these instructions carefully:

1. Turn the air cleaner off using the ON/OFF Rocker switch on the front panel.
2. Disconnect the input power to the air cleaner at the circuit breaker panel controlling the air cleaner.
3. Remove the door from the front of the unit to gain access to the two (2) screws holding the power supply assembly to the top of the air cleaner (See Figure 6).
4. Remove the screws to gain access to the inside of the power supply assembly.

5. Place screws in a safe place for re-installation after modification is complete.

6. Remove the two (2) blue wires from the air flow sensor by carefully sliding the connectors from the board (See Figure 13).

7. Cut the terminals from the end of both blue wires.

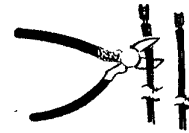

8. Strip the wires 1/2".



9. Using a wire nut or pigtail connector suitable for connecting two (2) each 18 gauge wires, connect the ends of the wires together.



10. After connection of the wires in the wire nut or pigtail connector, pull on the wires to insure a good electrical connection.

11. Remove the two (2) yellow wires from the air flow sensor (See Fig. 13).

12. Cut the terminals from the ends of the yellow wires.

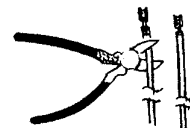

13. Double back the end of one (1) wire onto itself approximately 2" and tape with electrical tape.

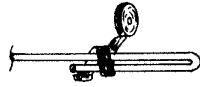

14. Repeat the procedure for the second yellow wire.
15. Replace the power supply assembly cover and secure with screws removed in Step 4.
16. Replace the unit door to the front of the air cleaner.
17. Your air cleaner will now operate when the door is in place the ON/OFF Rocker switch in the "ON" position and proper input voltage is present in the junction box.

VI. MAINTENANCE

CAUTION: Sharp Edges.
Handle the cells carefully to avoid cuts from the sharp metal edges.

WASHING CELLS AND PRE-FILTERS

Regular washing is necessary to insure proper performance. A thorough washing once every two months will be adequate for most installations. More frequent washing (once a month) may be necessary on some installations (new homes for example) where there is new

carpeting, plaster dust, or there is above normal cigarette smoke (See Fig. 15).

1. To remove cell(s) and pre-filter

- A. Push air cleaner switch to "OFF". Wait 15 seconds. Open access door.
- B. Carefully remove cells and pre-filter and set aside.
- C. Avoid damage to cell plates and ionizing wires.

2. To wash in a tub

- A. Place enough hot water in a utility tub to cover the cell. Dissolve 2 to 4 oz. of automatic dishwasher detergent (not laundry detergent) in the water.
- B. Allow the cell to soak for 30 minutes. Agitate it up and down in the solution until it appears clean, then remove.
- C. Repeat with second cell.
- D. Agitate the pre-filters up and down in the solution until they appear clean.
- E. With a hose, rinse the cells and pre-filters. The hose should be held about 10" from the cell plates and at a slight angle for better cleaning results. The cell frame should be thoroughly rinsed along the edges to dislodge any trapped lint or dirt. Carefully wipe a damp cloth or sandpaper (not emery cloth) along the ionizing wires.
- F. Stand cells and pre-filters up to drain. Let dry two hours.

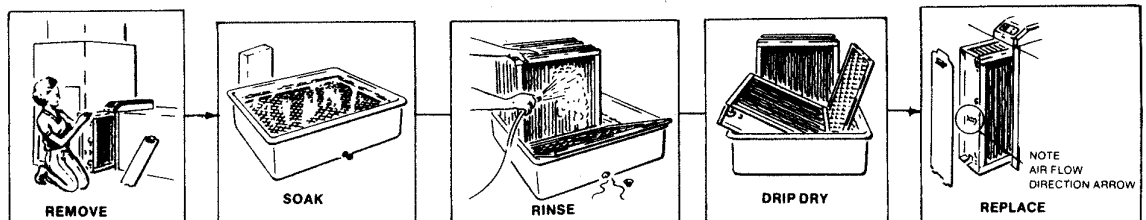

Figure 15

3. To replace a cell

- A. Replace pre-filter and cells in cabinet. Check that arrow on cells points in same direction as air flows through the duct. (If you have to force it past the positioning screw on bottom, it is probably in a wrong position.)
- B. Reposition access door (engage tips on lower edge of door into slots in cabinet). Carefully close door.
- C. Turn air cleaner switch to "ON".
- D. Remember, air flow sensor must go through stabilization period. See Note in Section V-System Checkout.

VII. TROUBLESHOOTING

The following instructions are for use by qualified personnel only:

WARNING:
The following procedures will expose hazardous live parts. Disconnect power between checks and proceed carefully

Recommended Service Tools

- Screwdriver, 8" common with insulated handle (plastic).
- Screwdrivers Phillips #1 and 2 with plastic insulated handles.
- Needle nose pliers.
- Fluke #8021B multimeter or equivalent.
- Fluke #80K-40 high voltage probe or equivalent.

Indication of Electrical Trouble

The air cleaner is equipped with an input power L.E.D light (green) and an output voltage L.E.D light (red) for indicating proper unit operation.

When the unit is in normal operation, system fan running, access door in place, control switch in the "ON" position, and the indicating lights go out, there is an electrical problem.

If the green light goes out there is a problem in the primary circuit. If the red light goes out the problem is a shorted secondary. Although failure of the indicating lights should not be overlooked, this condition is unusual and rather remote.

Electrical Troubles & Their Conditions

CAUTION:

- Exercise the usual precautions when working with high voltage.
- When the circuit has been de-energized, always discharge any residual current in the secondary with an insulated handle screwdriver
- Always ground power supply and ionizing-collecting cell when bench testing

1. PRIMARY CIRCUIT

If there is supply line voltage at the service connections and no input voltage to the power supply (green light out), the outage can be located by checking operation of the safety switch and the interconnecting wiring with a multimeter. Refer to Circuit Diagram, Figure 16 to check operation of the switches. Follow these steps:

1. Assure that the circuit breaker controlling the air cleaners is in the "ON" position. Main fuse not open.
2. Set the multimeter for reading AC voltage at a 200 volt full scale for 120 volt

units, or 750 volt full scale for 240 volt units.

3. Remove the two (2) blue leads from the air flow sensor. Refer to Figure 13. Connect the ends of the wires together to bypass the air flow sensor during the next service check.
4. Connect one lead of the multimeter to the load side of the interlock switch. Connect the other lead to the common (white) lead at a convenient place in the power supply assembly. Depress the switch and measure the voltage. If there is no voltage reading, the switch is defective and should be replaced.
5. With the white lead still connected as in step 4, connect the multimeter test lead to the loadside of the On/Off switch. On/Off switch shall be in the "On" position. Actuate the interlock switch and measure the voltage. If there is no

voltage reading, the On/Off switch is defective and should be replaced.

2. SECONDARY CIRCUIT

IONIZING-COLLECTING CELL

The cell is electrically energized through a contact terminal located at the top center of the cell. The ionizing wires and every other collector plate are electrically charged while each interleaving plate is grounded.

If the space between the charged and grounded plates is bridged with conductive or semi-conductive material, a short circuit develops. The bridging or short may be caused by damaged plates or foreign material lodged between or on the components.

Since the cell is periodically removed from the unit to wash away collected dirt,

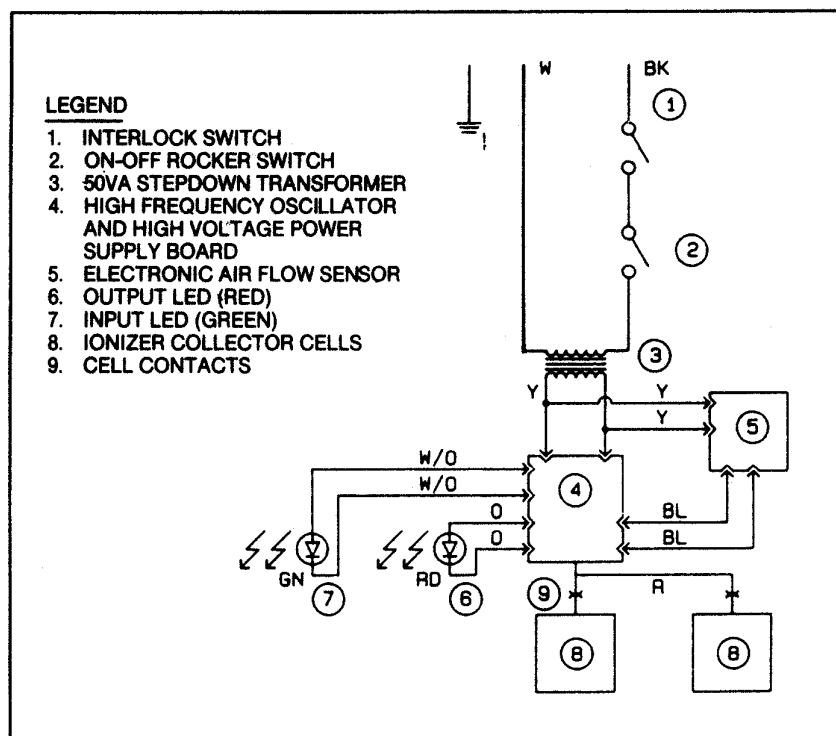

Figure 16

it is susceptible to physical damage. Also, the cell contains the ionizing wires which, due to their function, have to be designed with minimal structural support and are susceptible to breakage. However, trouble related to a shorted collector cell is readily shown by the output indicating light and can be quickly isolated by a simple procedure.

To determine if a short exists in one or both of the collector cells, turn the electronic air cleaner "OFF" and remove both electronic cells from the cabinet. Shut the door and re-power the unit. If the red performance light comes on, an electrical short exists in one or both of the

electronic cells. Replace the cells in the unit, one at a time, to determine which cell is shorted.

Most troubles in the cell can be visually detected and corrected (Table 17).

NOTE: The ionizer collector cells are not designed for field repair. Ionizing wires and insulators can be field replaced. It is not recommended to attempt to replace other cell components, i.e. collector plates, end plates, ionizer supports.

CELL CHECKOUT PROCEDURES

CAUSES	CORRECTIONS
Loose ionizing wire(s)	Replace loose wire(s)
Excessively dirty cell	Clean as outlined in Section VI
Damaged (bent) plates	Straighten or replace collector cell.
Improper ground This is a spring located on the cabinet assembly. Refer to Item 21 in Parts List.	Check ground. Replace Item 21 if it is bent or deformed.
Large pieces of foreign matter lodged between plates.	Remove
Very dirty insulators	Clean
Broken ionizing wires. Refer to Item 13 Parts List.	Remove all pieces of broken wires. Replace broken wire(s).
Excessively bent or misaligned components due to mishandling	Straighten bent plates or replace collector cells
Externally broken or cracked insulators	Replace insulator Ref. Item 22 in Parts List

Table 17

IONIZING WIRE REPLACEMENT

Ionizing wire breakage is minimal because of the constant tension design and fixed location of the ionizing wire supports, if necessary to replace a broken wire follow these instructions.

Wires are supplied in a coiled spring configuration, with a clinch nut on each end of the wire.

Wire replacement requires a pair of needle nose pliers. Exercise caution in removing any broken wires in the collector cell. This will prevent accidental shorting of the cell and reduce the need for further maintenance.

Use the following procedure when replacing an ionizing wire.

NOTICE: Handle with care as parts are sharp.

1. Carefully remove all remains of the broken wire.
2. Grip the new wire at each end of the wire with your thumb and index finger. While stretching the wire to approximately 6" allow one end of the wire to uncoil between your thumb and index finger.
3. Place one end of the wire in the slot in the stainless steel support on the collector cell from the front of the cell. This support is partially covered by the cell brace in front of the support.
4. Grip the other end of the ionizing wire with needle nose pliers and insert the terminated end of the wire into the slot on the support bar of the

opposite end of the collector cell.

5. The wire should be tight enough to be self supporting and remain suspended between the two support slots in the support bar.

3. POWER SUPPLY

If the output light remains out with the cells removed, the trouble is in the power supply. Specific problems in the power pack assembly can be isolated by using a multimeter and high voltage probe to check for proper output voltages.

To properly check the power supply, follow these steps:

1. Remove power pack access cover.
2. Make sure the control switch is on and input voltage is 120 volts, 60 Hz (or 240 volts, 50/60 Hertz).
3. Set the multimeter to read AC voltage. Use the 200 volt full scale setting. With test leads attached to the multimeter, touch the two transformer output lead junctions to the printed circuit board and read the meter.
4. **If there is no output voltage from 24 volt transformer, replace 24 volt transformer and power supply board.**
5. If there is proper output voltage from 24 volt transformer, replace power supply board.

4. AIR FLOW SWITCH

The air cleaner is designed for easy wiring and installation; attaching two leads to the nearest 120/240 volt power source

will put the MAX 5 into operation. The MAX 5 cannot be wired into the motor leads. On multiple speed blower taps, we have seen voltages exceed 190 VAC (120 volt motors). This voltage can double with 240 volt input. This kind of input voltage will damage both the power supply and air flow switch and void the warranty.

The air flow switch uses a thermistor and is designed for years of trouble free service when handled properly. Whenever servicing the air flow switch, power must be disconnected and the unit must be turned off. If the thermistor touches the bracket or the power pack cover when it is energized, it will short the sensor. The sensor must then be replaced. Also, ensure that the blue and yellow leads are connected properly when replacing an air flow switch; blue leads to terminals labeled TR, yellow leads to terminals labeled AC. Ensure the edge connectors when installed are making contact with the printed circuit pads on the back side of the sensor board.

If the air cleaner is installed in crawl spaces or attics that are extremely dusty and dirty, the sensor on the air flow switch over a period of time can be covered with dirt and become inoperative because air flow over the thermistor is unable to cool it. The result is the air cleaner will not energize. In these applications, periodically cleaning the sensor through the side of the power pack with a cotton swab dipped in rubbing alcohol will restore it to full operational use.

On continuous blower applications, after servicing the air cleaner, cleaning the cells or power outages by the utility company, the air flow switch must be reset. This reset requires that the air

handler in the furnace/air conditioner be stopped a minimum of 2 minutes to allow the airflow switch to reset. To stop the air handler, turn the fan switch on the thermostat to the off position. Reset the thermostat to heating/cooling as required.

VIII. ADDITIONAL CHECKOUT PROCEDURES

The following instructions are for use by qualified personnel only:

WARNING: The following procedures will expose hazardous live parts. Disconnect power between checks and proceed carefully.

The secondary circuit can also be checked for proper output voltages using a multimeter and high voltage probe. To check for proper operation, follow these steps:

1. Remove power pack access cover.
2. Make sure the control switch is on and input voltage is as specified.
3. Short the air flow sensor switch by connecting the two blue leads to each other as outlined in the Power Supply section.
4. Make connections from the high voltage probe to the multimeter in accordance with the operator's manual. The meter should be set for reading DC voltage on the 20 volt full scale. Need a check of the contact board assembly prior to checking cells for damage or carbon path. See NOTE.

NOTE: The cell contacts should be visually checked for corrosion, excessive dirt build up, and electrical arc tracking (carbon path from stainless steel spring to grounded metal).

5. Remove the cell access door. Attach the high voltage ground lead from the high voltage probe to the cabinet. While depressing the safety switch lever, touch the ionizer wire support bar with the end of the high voltage probe (Fig 18). The meter should read 6.2 kVDC \pm .2 kVDC. (6.8 kVDC \pm .2 kVDC for 1400 SQ)

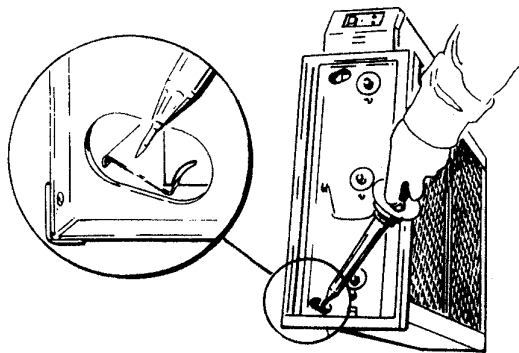

Figure 18

6. If no voltage is measured, remove the cell and check the second cell. The meter should read 6.2 kVDC \pm .2 kVDC. (6.8 kVDC \pm .2 kVDC for 1400 SQ)

7. If proper voltage is measured, the first cell is shorted Refer to Table 17.

8. If no voltage is present, remove the second cell. Install cell number one and measure voltage as described above. If voltage is present, the second cell, which is now out of the cabinet, is shorted Refer to Table 17 for Cell Checkout procedure.

9. If no voltage is present, remove both cells and measure the power supply

output. While depressing the safety switch, touch the end of the high voltage probe to either the front or rear contact board assembly (Figure 19). The meter should read 6.2 kVDC or higher.

10. If no voltage is measured, check the power supply as outlined in the Power Supply section.

11. Set the multimeter for reading AC voltage at a 200 volt full scale. With test leads attached to the multimeter, touch the two transformer output lead junctions to the printed circuit board and read the meter.

12. **If there is no output voltage from 24 volt transformer, replace 24 volt transformer and power supply.**

13. If there is proper output voltage from 24 volt transformer, replace power supply.

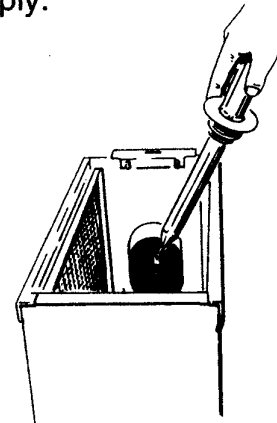

Figure 19

IX. OTHER FACTS YOU SHOULD KNOW

White Dust

Occasionally a "white dust" might be noticed in bedrooms or newly furnished rooms. This is mainly composed of lint

which, because of its weight, settles before it reaches your unit. This dust is not mixed with airborne dirt, therefore, it is clean and has no staining or soiling properties. It will lessen as the excess lint works out of the fabrics.

Ozone

Under normal operating conditions all electrostatic air cleaners produce minute quantities of ozone as an incidental by-product, as do televisions and other electrical appliances. The design of the unit has been tested and is far below the published permissible limits. The level of detection (when it is noticed) varies from individual to individual, some being more sensitive to ozone.

Usually a new unit will produce more ozone than one that has been in operation for several weeks. This is due to the normal amount of sharp corners or manufacturing burrs on the ionizing - collecting cell. The voltage working on these areas, however, tends to round them off and the problem is self-correcting.

An ionizing-collecting cell that has been damaged, where the designed spacing between electrically charged and ground components has been decreased, may also produce an abnormal amount of ozone.

High Altitude Operation

Because the air is less dense at higher altitudes, there is a possibility of nuisance arcing. To reduce this annoyance, refer to the following note. Cutting of red jumper wire will reduce voltage and eliminate arcing. The red

jumper wire must be cut in installations of over 5,000 feet elevations; see Figure 20.

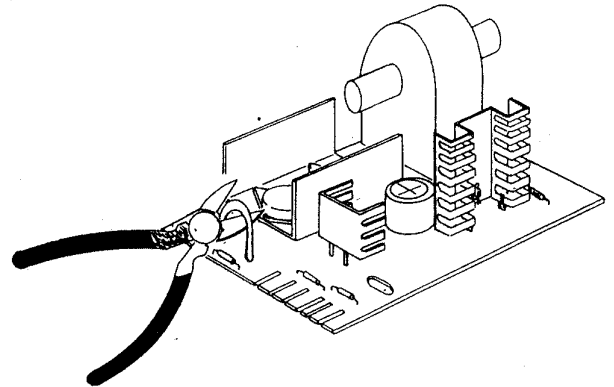

Figure 20

NOTE: There is a red jumper wire on the power supply printed circuit board, cutting this jumper will slightly reduce the output voltage and reduce the ozone level.

If there appears to be excess ozone, check for:

- **Damaged (bent) plates**
Straighten or replace collector cell
- **Loose ionizing wires**
Replace
- **Dirty cell**
Clean
- **Loose high voltage connections**
Repair or replace
- **Radio &/or Television Interference**
This trouble is not common, but when it occurs it is usually due to either a continuous high voltage "leak or

discharge", or due to the absence of a good common electrical ground. Refer to conditions listed under "Crackling and Snapping" in the Flow Chart.

TROUBLE SHOOTING THE DUCT MOUNT ELECTRONIC AIR CLEANER

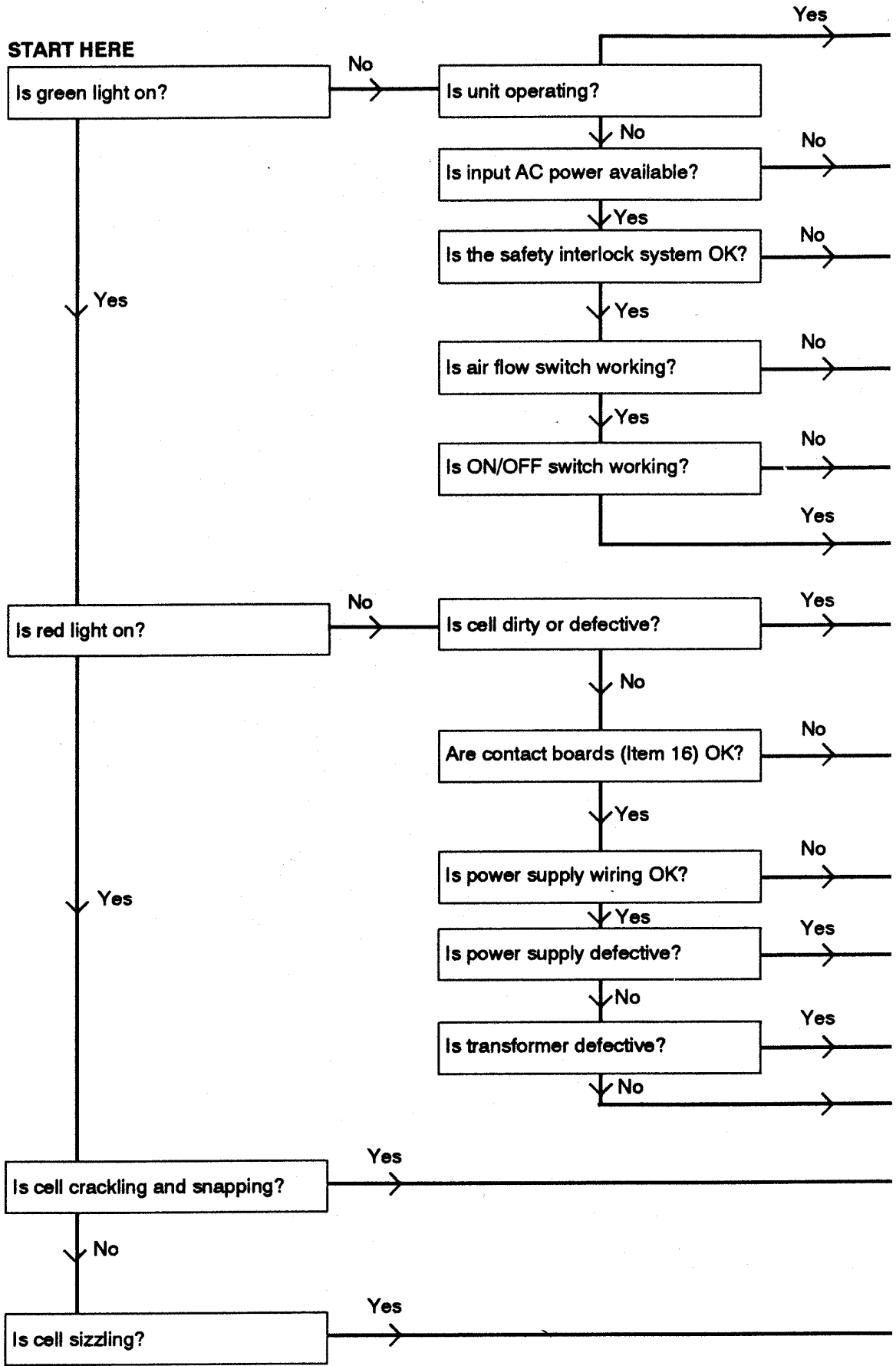

WARNING: The following steps will expose hazardous live parts. Disconnect power between checks and proceed carefully.

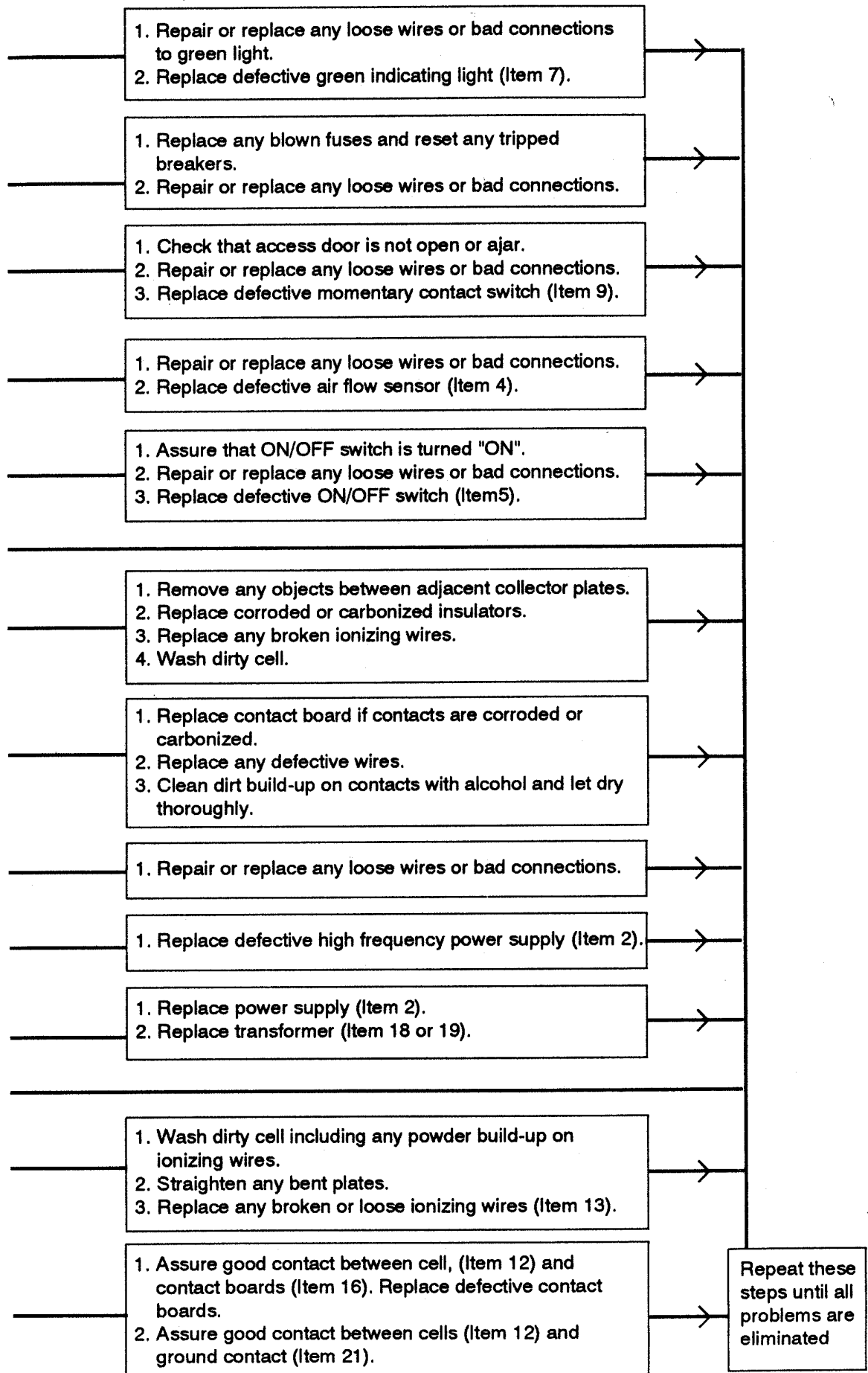

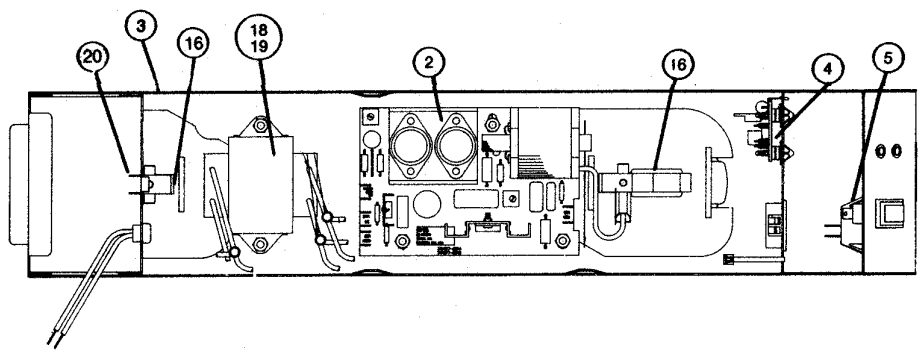
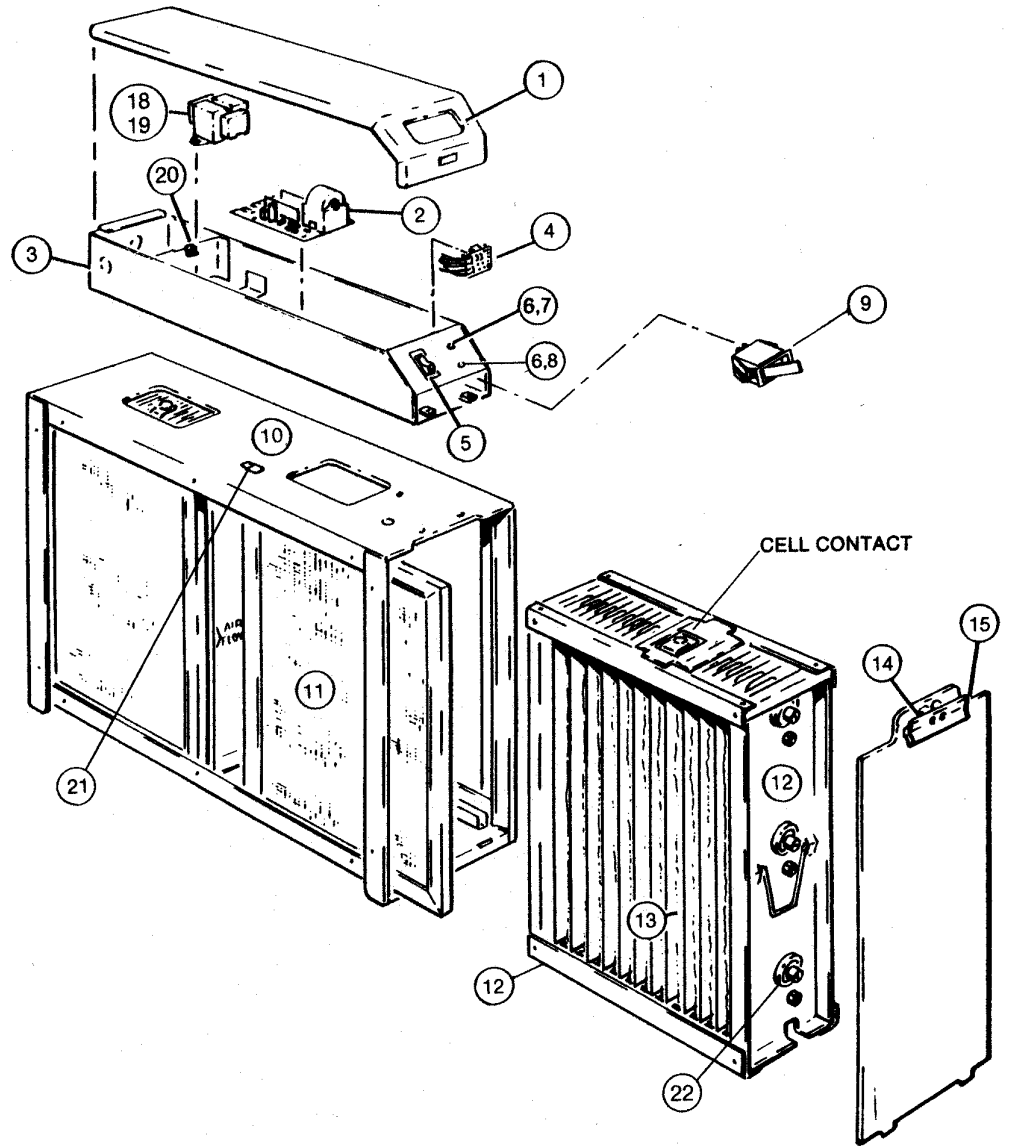

PARTS LIST FOR BLACK UNIT

Ref. No.	Description	MAX 5 1400 441501-001	MAX 5 2000 441500-001	MAX 5 1400 SQ 20 x 20 441890-001	TRIM TX 441502-001
1	Power Pack Cover	334370-005	334370-005	334370-005	334370-005
2	High Frequency Power Supply	341677-601B	341677-601A	341677-601A	341677-601B
3	Power Pack Assembly, 120 Volt	441891-002	441891-001	441891-020	441891-002
3A	Power Pack Assembly, 240 Volt	441891-014	441891-013	441891-024	441891-014
4	Electronic Air Flow Sensor	244500-001	244500-001	244500-001	244500-001
5	On/Off Switch	138586-001	138586-001	138586-001	138586-001
6	LED Mounting Clip	133548-001	133548-001	133548-001	133548-001
7	Input Voltage LED Assembly (Green)	134516-007	134516-007	134516-007	134516-007
8	Output Voltage LED Assembly (Red)	134516-006	134516-006	134516-006	134516-006
9	Contact Switch	244833-001	244833-001	244833-001	244833-001
10	Cabinet Assembly	338892-002	338892-001	339517-001	338751-002
11	Pre-filter	123324-005	123324-004	123324-007	123324-008
12	Cell, Ionizing-Collecting	441730-101	441729-101	441729-102	441731-101
13	Ionizing Wire Assembly (1 Wire)	220110-020	220110-029	220110-029	220110-015
14	Handle	241831-001	241831-001	241831-001	241831-001
15	Front Panel Door Assembly, 120 Volt	341892-002	341892-005	341892-003	341892-004
15A	Front Panel Door Assembly, 240 Volt	341892-006	341892-005	341892-007	341892-008
16	Contact Board Assembly (2 Req'd)	345109-001	345109-001	345109-001	345109-001
17	Charcoal Filter (optional-not shown)	227833-003	227833-004	227833-006	227833-003
18	Step Down Transformer 120 to 24 Volts AC	239071-001	239071-001	239071-001	239071-001
19	Step Down Transformer 240 to 24 Volts AC	239071-002	239071-002	239071-002	239071-002
20	Ground Clip	138885-001	138885-001	138885-001	138885-001
21	Ground Contact	142153-001	142153-001	142153-001	142153-001
22	Insulator	246287-001	246287-001	246533-001	246287-001
23	Plastic Positioning Spacer (not shown-See Fig 5)	143839-001	143839-001	143839-001	143839-001

All units also available in 240 volt

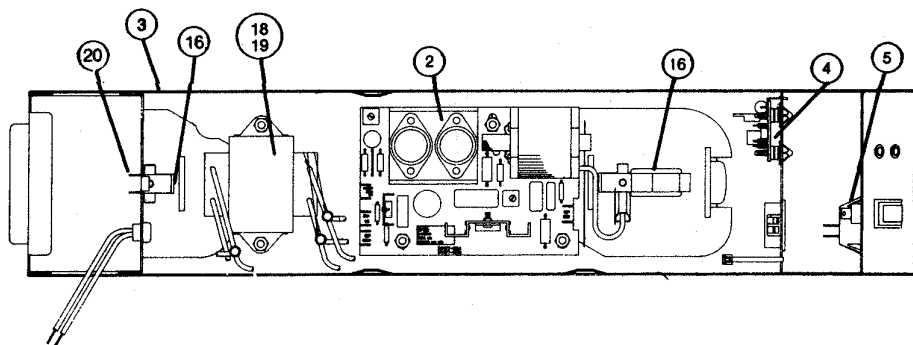
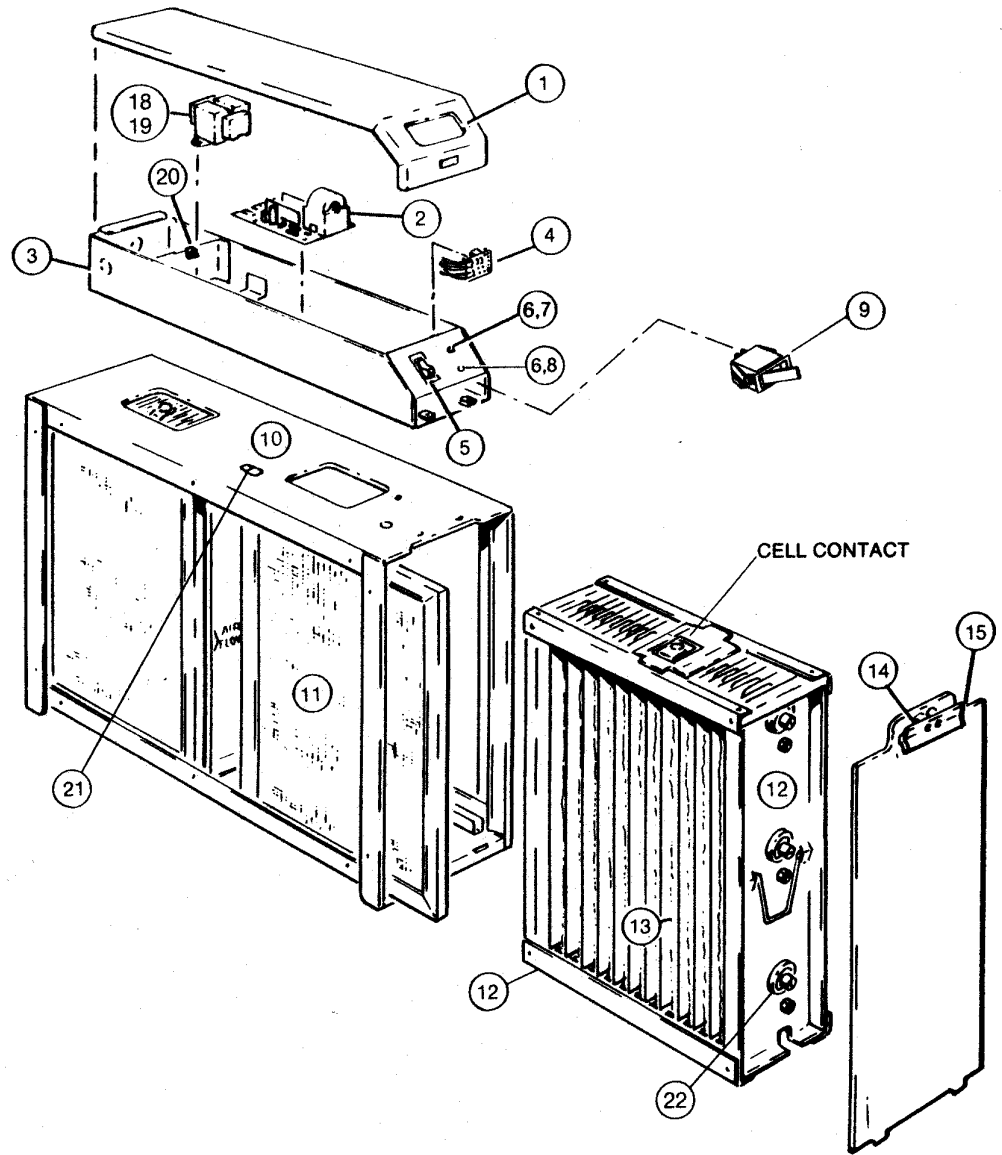

PARTS LIST FOR LIGHT NEUTRAL UNIT

Ref. No.	Description	MAX 5 1400 441501-019	MAX 5 2000 441500-019	MAX 5 1400 SQ 20 x 20 441890-014	TRIM TX 441502-010
1	Power Pack Cover	334370-014	334370-014	334370-014	334370-014
2	High Frequency Power Supply	341677-601B	341677-601A	341677-601A	341677-601B
3	Power Pack Assembly, 120 Volt	441891-042	441891-041	441891-045	441891-042
3A	Power Pack Assembly, 240 Volt	441891-044	441891-043	441891-046	441891-044
4	Electronic Air Flow Sensor	244500-001	244500-001	244500-001	244500-001
5	On/Off Switch	138586-001	138586-001	138586-001	138586-001
6	LED Mounting Clip	133548-001	133548-001	133548-001	133548-001
7	Input Voltage LED Assembly (Green)	134516-007	134516-007	134516-007	134516-007
8	Output Voltage LED Assembly (Red)	134516-006	134516-006	134516-006	134516-006
9	Contact Switch	244833-001	244833-001	244833-001	244833-001
10	Cabinet Assembly	338892-025	338892-024	339517-008	338751-007
11	Pre-filter	123324-005	123324-004	123324-007	123324-008
12	Cell, Ionizing-Collecting	441730-101	441729-101	441729-102	441731-101
13	Ionizing Wire Assembly (1 Wire)	220110-020	220110-029	220110-029	220110-015
14	Handle	241831-005	241831-005	241831-005	241831-005
15	Front Panel Door Assembly, 120 Volt	341892-013	341892-016	341892-014	341892-015
15A	Front Panel Door Assembly, 240 Volt	341892-017	341892-016	341892-018	341892-019
16	Contact Board Assembly (2 Req'd)	345109-001	345109-001	345109-001	345109-001
17	Charcoal Filter (optional-not shown)	227833-003	227833-004	227833-006	227833-003
18	Step Down Transformer 120 to 24 Volts AC	239071-001	239071-001	239071-001	239071-001
19	Step Down Transformer 240 to 24 Volts AC	239071-002	239071-002	239071-002	239071-002
20	Ground Clip	138885-001	138885-001	138885-001	138885-001
21	Ground Contact	142153-001	142153-001	142153-001	142153-001
22	Insulator	246287-001	246287-001	246533-001	246287-001
23	Plastic Positioning Spacer (not shown-See Fig 5)	143839-001	143839-001	143839-001	143839-001

All units also available in 240 volt

ELECTRONIC AIR CLEANER LIMITED TWO-YEAR WARRANTY

This limited warranty covers Trion Residential Type Electronic Air Cleaners, excluding duct work, wiring and installation.

Trion, Inc. warrants that all new Trion Electronic Residential Air Cleaners are free from defects in material and workmanship under normal, noncommercial use and service. Trion will remedy any such defects if they appear within 24 months from the date of original installation as evidenced by receipt of the warranty registration card, subject to the terms and conditions of this Limited Two-Year Warranty stated below:

1. THIS LIMITED TWO-YEAR WARRANTY IS GRANTED BY TRION; INC., McNEILL ROAD, P.O. BOX 760, SANFORD, NORTH CAROLINA 27330.
2. This warranty shall extend only to any noncommercial owner who has purchased the residential electronic air cleaner other than for purposes of resale.
3. The completion and return of the Warranty Registration Card is a condition precedent to warranty coverage and performance. This warranty is not valid unless this card is completed and mailed to the factory within fifteen (15) days of equipment installation.
4. All components are covered by this limited warranty except expendable items, such as charcoal filters and disposable dirt holding pads.
5. If within the warranty period any Trion residential electronic air cleaner unit or component requires service it must be performed by a competent heating and/or air conditioning contractor (preferably the installing contractor). Trion, Inc. will not pay shipping charges, or labor charges to remove or replace such defective parts or components. If the part or component is found by inspection to contain such defective material and workmanship it will be either repaired or exchanged free of charge at Trion's option, and returned freight collect.
6. In order to obtain the benefits of this limited two-year warranty, the owner must notify the dealer or distributor in writing of any defect within 30 days of its discovery. If after reasonable time you have not received an adequate response from the dealer or distributor, notify in writing Trion, Inc., McNeill Road, P.O. Box 760, Sanford, North Carolina 27330. Console or portable models of the electronic air cleaner may be returned intact freight prepaid, but electronic air cleaners which have **been installed** or become part of real estate cannot be returned. Trion will receive, freight prepaid, only removable parts or components of such defective electronic air cleaners.
7. This limited warranty does not apply to any part or component that is: damaged in transit or when handling, has been subject to misuse, neglect or accident; has not been installed, operated and serviced according to Trion's instruction; has been operated beyond the factory rated capacity; or altered in any such way that its performance is affected. There is no warranty due to neglect, alteration or ordinary wear and tear. Trion's liability is limited to replacement of defective parts or components and does not include the payment of the cost of labor charges to remove or replace such defective components or parts.
8. Trion will not be responsible for loss of use of any product; loss of time, inconvenience, or any other indirect, incidental or consequential damages with respect to person or property, whether as a result of breach of warranty, neglect or otherwise. **SOME STATES DO NOT ALLOW THE EXCLUSION OR LIMITATION OF INCIDENTAL OR CONSEQUENTIAL DAMAGES, SO THE LIMITATION OR EXCLUSION IN THE PRECEDING SENTENCE MAY NOT APPLY TO YOU.**
9. **THIS WARRANTY GIVES YOU SPECIFIC RIGHTS, AND YOU MAY ALSO HAVE OTHER RIGHTS WHICH VARY FROM STATE TO STATE.**
10. Any warranty work will be performed within a reasonable time, usually within 120 days after notice of defect and delivery to the Trion factory, subject to delays beyond Trion's control.
11. Any warranty be Trion of merchantability, fitness for use or any other warranty (express, implied or statutory), representation or guarantee other than those set forth herein, shall expire at the expiration date of this express limited warranty. **SOME STATES DO NOT ALLOW LIMITATIONS ON HOW LONG AN IMPLIED WARRANTY LASTS, SO THE LIMITATION IN THE PRECEDING SENTENCE MAY NOT APPLY TO YOU.**
12. Trion reserves the right to make changes in the design and material of its products without incurring any obligation to incorporate such changes in units completed on the effective date of such change.

FOR OWNER'S INFORMATION

PRODUCT MODEL

INSTALLATION DATE

UNIT SERIAL NO.

INSTALLED BY (DEALER)

OWNER RESPONSIBILITIES

The completion and return of the Warranty Registration Card is a condition precedent to warranty coverage and performance. This warranty is not valid unless the warranty card is completed and mailed to the factory within fifteen (15) days of equipment installation.

TRION Inc.

P.O Box 760 • 101 McNeill Road
Sanford, North Carolina 27331-0760
Phone: (919) 775-2201 • Fax: (919) 774-8771