

This Owner's Manual is provided and hosted by [Appliance Factory Parts](#).

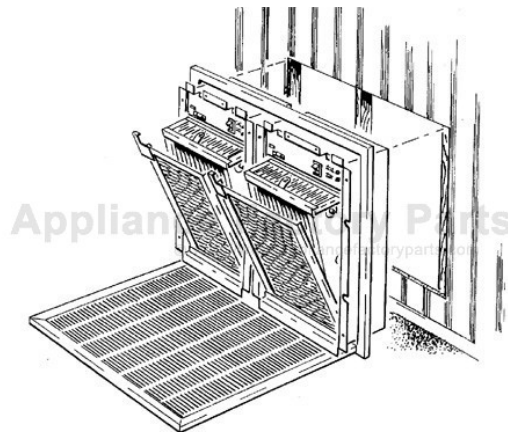

# HERRMIDIFIER TGM2 2000 Owner's Manual

[Shop genuine replacement parts for HERRMIDIFIER  
TGM2 2000](#)



[Find Your HERRMIDIFIER Air Cleaner Parts - Select From 27 Models](#)

----- Manual continues below -----

# **TRION**

## **TGM 2** **GRILL MOUNT** **ELECTRONIC AIR CLEANER**

### **MANUAL FOR**

- **INSTALLATION**
- **OPERATION**
- **SERVICE**

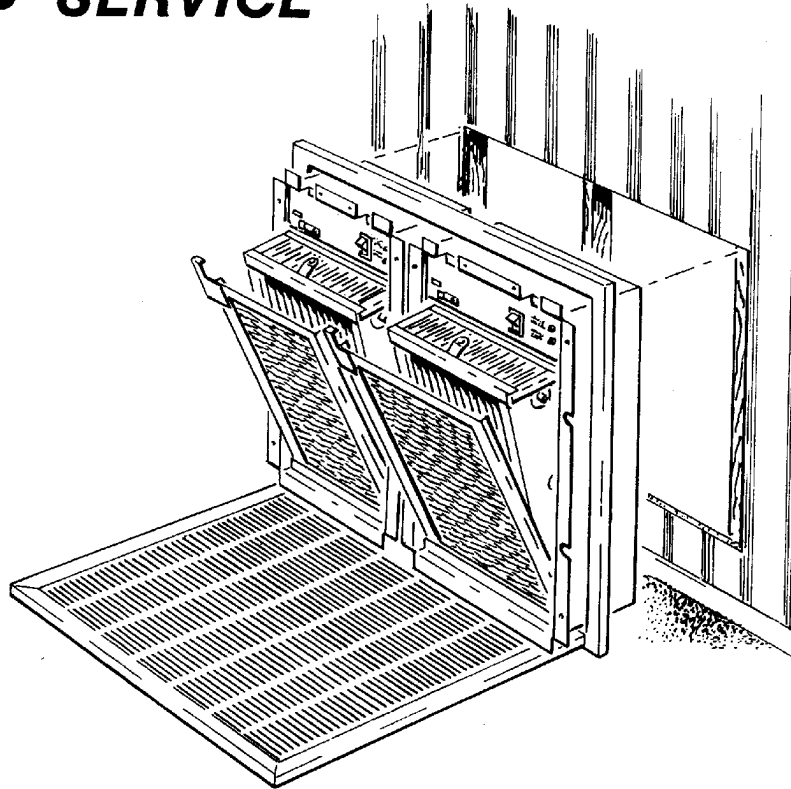

**CAUTION:**

**Read rules and instructions carefully for safe operation.  
Exercise the usual precautions when working with high voltage.**

## II. PLANNING THE INSTALLATION LOCATION

These air cleaners are designed for efficient and economical air cleaning in areas with central return air grills. They may be installed in ceilings, side walls or

closets, saving room space and making installation easier.

Consideration should be given for user removal of pre-filter and collecting cell. (See Figure 1).

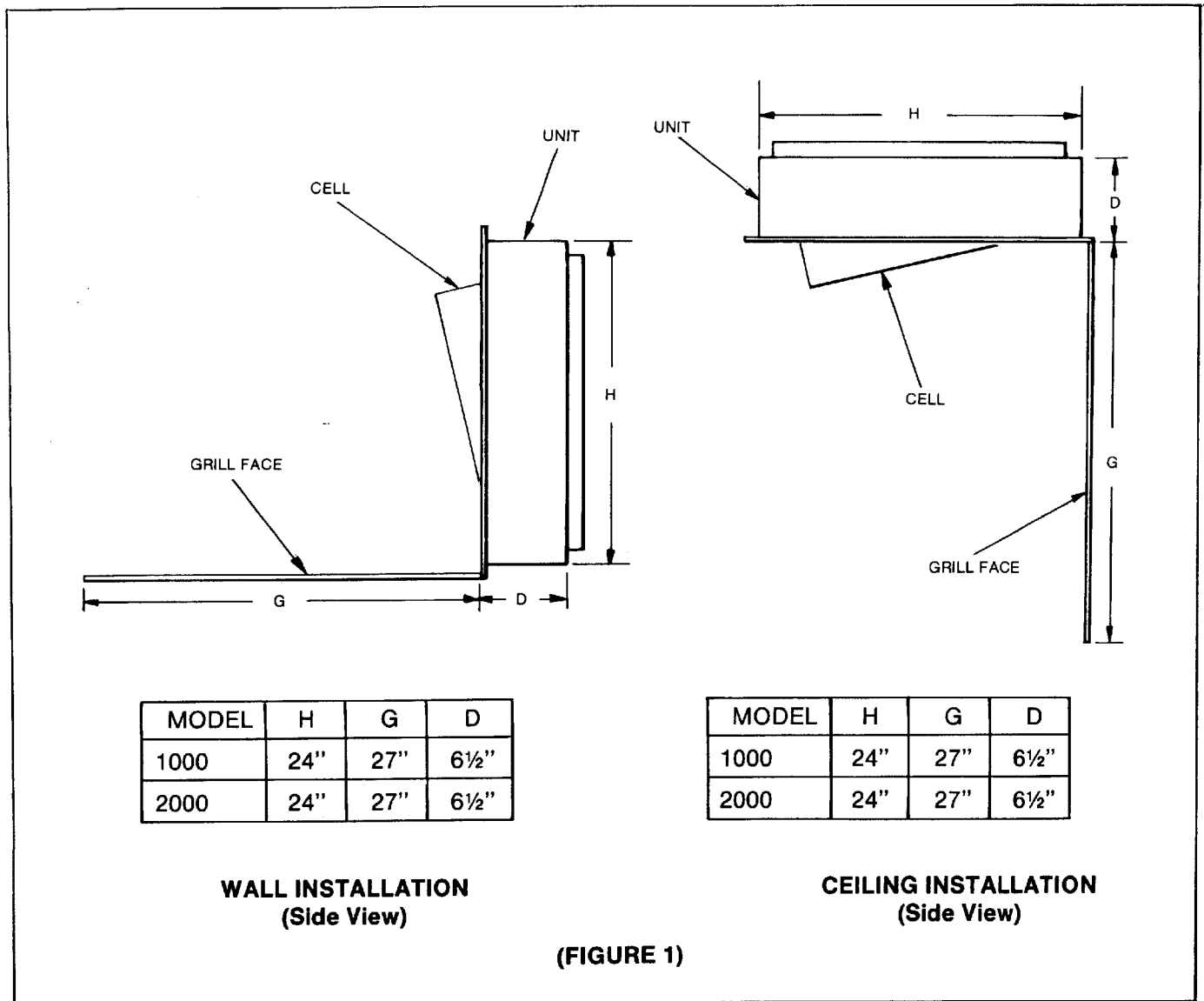

## III. FRAMING

Frame unit in desired location. See Rough In Dimension, Figure 3.

Installed unit will extend approximately 7½" into the air space behind finished wall or ceiling surface. An additional 8" - 12" of free air space behind the unit assures uniform airflow.

## IV. DUCT WORK

Duct work may be attached directly to the rear of the air cleaner. A ½" flange is provided as are mounting holes for No. 8 sheet metal screws. Recessed mounting holes are located in the sides of the air cleaner for use in ceiling installations.

If the air duct does not fit the air cleaner cabinet opening; (1) gradual transitions are recommended to reduce air turbulence through the air cleaner to maximize efficiency, (2) not more than 20° (about 4" per running foot) of expansion should be used on each side of the transition fitting.

## V. INSTALLATION

### A. Installation without stud or ceiling joist.

#### CENTER BRACES REQUIRED (Model 2000 only)

1. Cut opening.
2. Remove grill frame from box and insert into hole opening (no screws required at this point). (See Figure 4).
3. Release pre-filter latch and remove pre-filter and collection cell.
4. Slide air cleaner module into grill frame.
5. Unit now ready to install into rough-in opening.

For wood opening, secure unit to rough framing with six # 10 x 1½" panhead wo screws. (Screws not included).

### B. Installation in wall or ceiling with center stud joist.

#### CENTER BRACES NOT REQUIRED (Model 2000 on

— When using 2 x 4 stud or ceiling joist as center support, bracing brackets attached with each unit are not required. Remove factory installed bracing brackets.

1. Cut drywall as shown leaving center stud or joist intact. (See Figure 4).

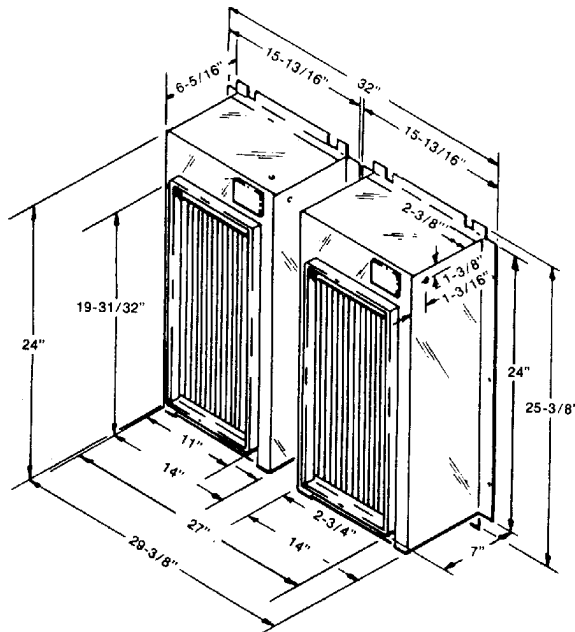

MODEL 2000

UNIT DIMENSIONS  
(FIGURE 2)

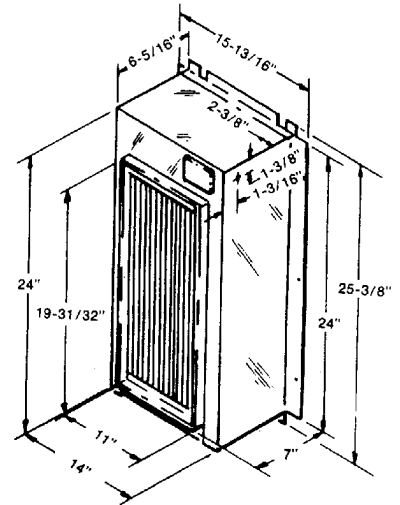

MODEL 1000

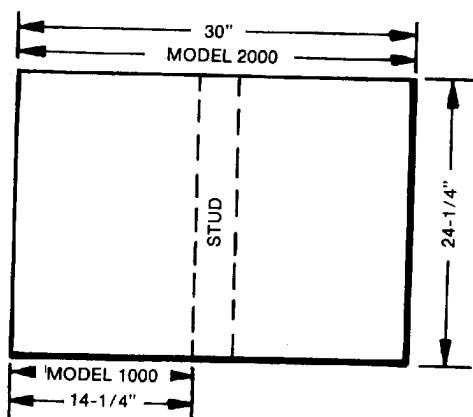

MODEL 2000

ROUGH-IN DIMENSIONS  
(FIGURE 3)

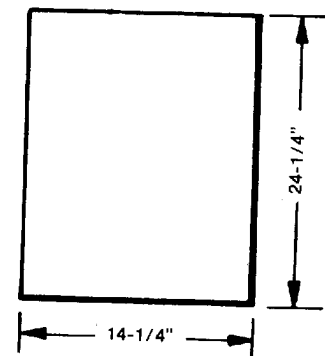

MODEL 1000

2. Remove grill frame from box and insert into hole opening (no screws required at this point). (See Figure 4).
3. Release pre-filter latch and remove pre-filter and collection cell.
4. Slide air cleaner module into grill frame.

#### 5. Installing Cabinet Housing Assembly

Secure the assembly by matching screw holes in grill frame to those on modular flanges. Use # 10 x 1½" panhead wood screws to secure unit to the stud. (Screws not included). Six (6) screws are required per module.

For second assembly, repeat above procedure.

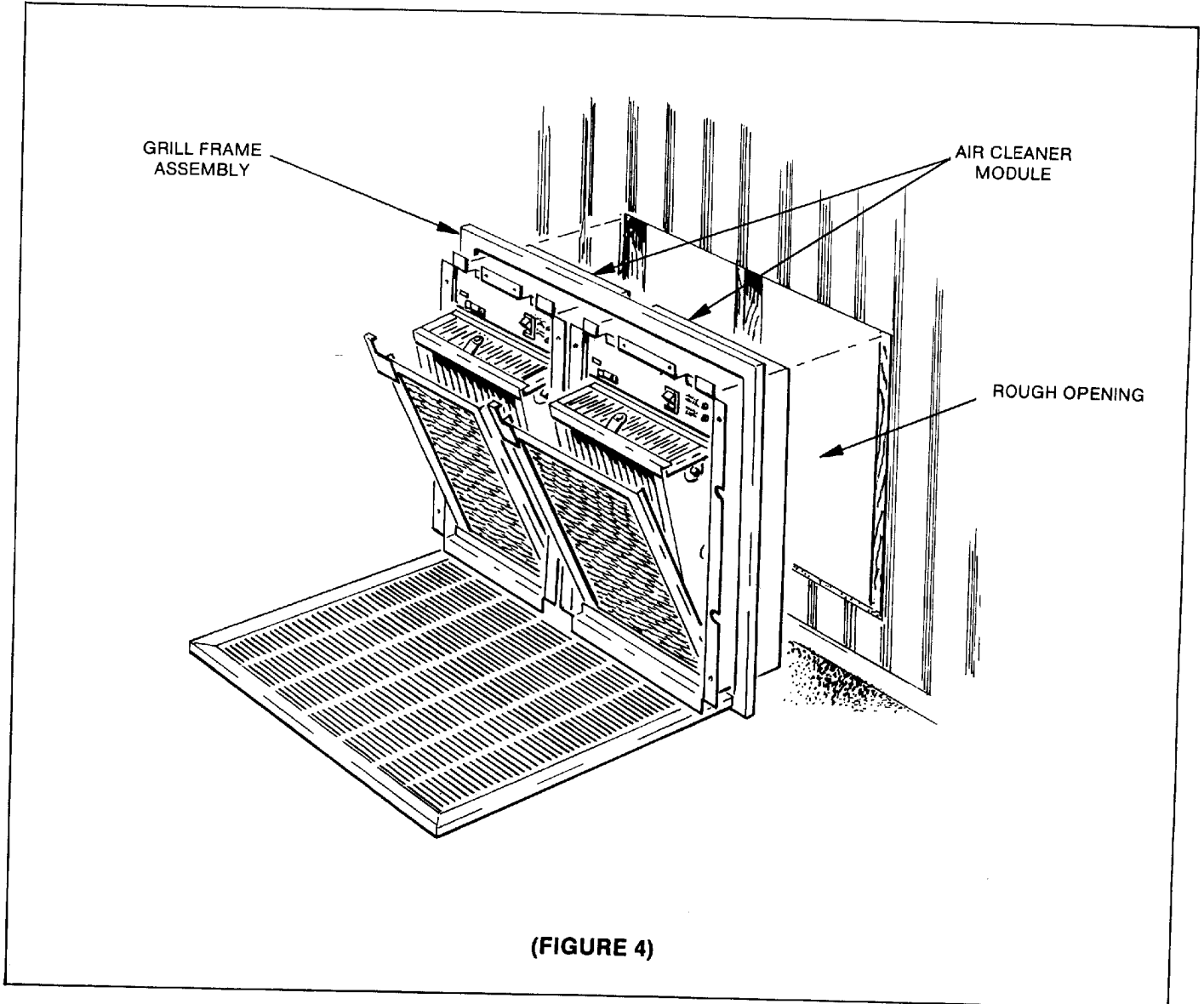

\*When using 2 x 4 stud or ceiling joist as center support, bracing brackets provided with each Model 2000 are not required. Remove factory installed bracing brackets.

## VI. ELECTRICAL WIRING

Electrical access panel is located on the back of the air cleaner cabinet assembly.  $\frac{7}{8}$ " knockouts are provided on the top and side of the air cleaner module. Wire the unit to a 120 volt, 60 HZ, 1 phase power supply so that the air cleaner is energized only in conjunction with the system blower. The air cleaner can only remove the airborne contaminants delivered to it by the system blower. To obtain maximum efficiency, adjust the system blower controls for continuous or as near continuous operation as practical. Sail switches, relays or other devices may also be used to energize the air cleaner when air is moving through the system.

Field wiring requires connecting black and white leads to corresponding house current input. Connect incoming ground (green) wire to corresponding green ground wire from air cleaner junction box. (See Figure 5).

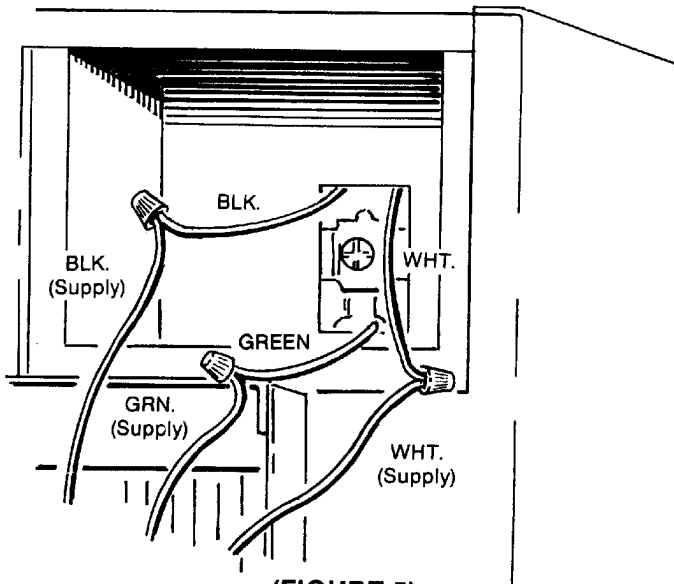

(FIGURE 5)

### NOTE:

The Model TGM 2000 has two power supplies. Connect these power supplies in parallel to operate with the system blower.

## VII. SYSTEM CHECKOUT

After assembling and installing the unit, move the power switch to the "ON" position. (Be sure system blower is "ON").

A. Both the input voltage light (green) and the output voltage light (red) should now be on.

1. Input voltage light shows unit has line voltage (120 volts).

2. Output voltage light (red) shows high voltage output to collecting cells.

B. Safety interlock checkout.

Release pre-filter latch and slide out to stop. Input voltage light (green) and output voltage light (red) should both go out.

C. If either light does not function as described above, see Service Section (Page 13).

## VIII. TROUBLE SHOOTING

### Tools Required

- (2) screw drivers, 8" blade type with insulated handle
- Needle nose pliers
- Volt/ohm meter (If Available)
- High voltage meter to 10,000 volts DC plus (If Available)

There are two areas in which the majority of service problems originate:

1. The ionizing-collecting cell
2. The power supply

### A. Electrical Trouble

### CAUTION

- EXERCISE USUAL PRECAUTIONS WHEN WORKING WITH HIGH VOLTAGE.
- WHEN THE CIRCUIT HAS BEEN DE-ENERGIZED ALWAYS DISCHARGE ANY RESIDUAL CURRENT IN THE SECONDARY WITH AN INSULATED HANDLE SCREW DRIVER.
- ALWAYS GROUND POWER SUPPLY AND IONIZING-COLLECTING CELL WHEN BENCH TESTING

#### 1. Ionizing-Collecting Cell

The cell is electrically energized through a contact terminal located at the top center of the cell. The ionizing wires and every other collector plate are electrically charged while each interleaving plate is ground. Most problems in the cell can be detected visually.

# WARNING

IMPROPER FIELD WIRING WILL VOID ALL WARRANTIES ON THIS PRODUCT.

**NOTE:** DIRECT WIRING TO A MULTI-SPEED BLOWER MOTOR WILL CAUSE FAILURE OF THE POWER SUPPLY IN THIS UNIT.

PLEASE REFER TO THE FOLLOWING TYPICAL WIRING DIAGRAMS FOR PROPER INSTALLATION. THESE DIAGRAMS DO NOT REFLECT ANY PARTICULAR FURNACE BLOWER SYSTEM.

PLEASE CONSULT THE WIRING DIAGRAM OF THE FURNACE FOR FURTHER INFORMATION.

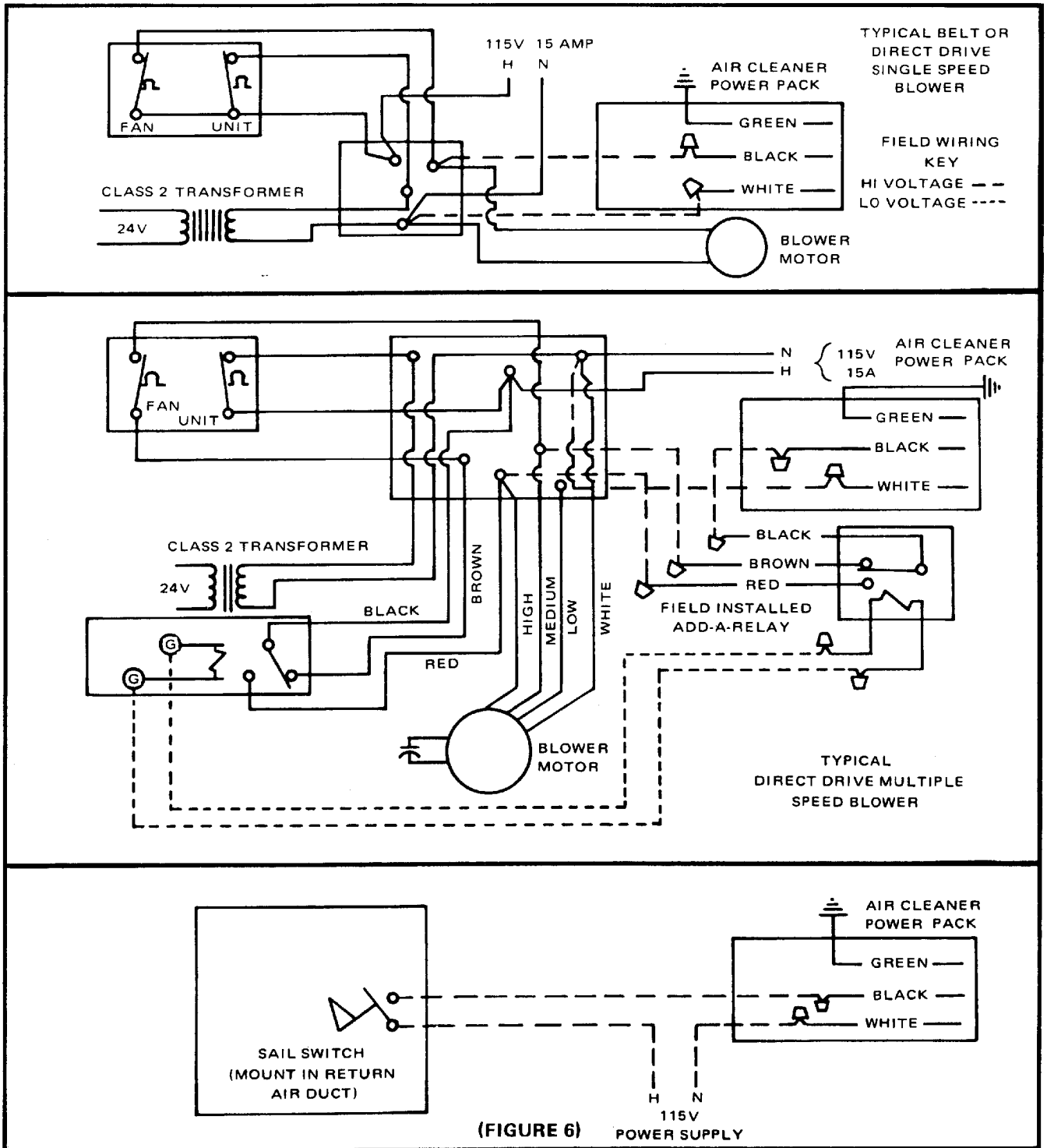

**Problem Areas**

**Corrections**

- |  |   |
|--|---|
| ● Excessive dirt build-up                                      | ● Wash  |
| ● Large pieces of foreign matter lodged between plates         | ● Remove  |
| ● Very dirty insulators  | ● Clean   |
| ● Broken ionizing wires  | ● Remove all pieces of broken wires and replace |
| ● Excessively bent or misaligned components due to mishandling | ● Straighten or replace                         |
| ● Externally broken or cracked insulators                      | ● Replace                                       |

**System Check**

A simple system check can be made by drawing an arc as follows:

- Remove pre-filter.
- Use screw driver to energize safety switch.

If high volt meter not available, proceed as follows:

- Use an insulated screw driver to draw an arc between extended ground plate and ionizing

wire. A sharp electrical arc of approximately 1/4" should be observed. This indicates proper cell operation. If weak arc or no arc is observed follow cell and power supply checkout.

**2. Power Supply (without high volt meter)**

If there is primary power to the power supply and the secondary output voltage is absent or very low the power supply is defective. A simple check can be made by drawing an arc, with an insulated handle screwdriver between common ground and high voltage output terminal (C). A good power supply will produce a pronounced arc whereas a defective one will produce no arc at all or a very weak one.

**3. Power Supply Check (with DC high volt meter)**

Take reading with the high voltage meter at contact point. Should range 8.5 + 10% KV higher (without cell connected).

If voltage is above 8.5 + 10% KV, the problem is in the cell (see cell checkout procedure).

If voltage is below 8.5 + 10% KV (without cell connected), the problem is in the power supply.

Proceed as follows:

- Remove power pack from the unit.

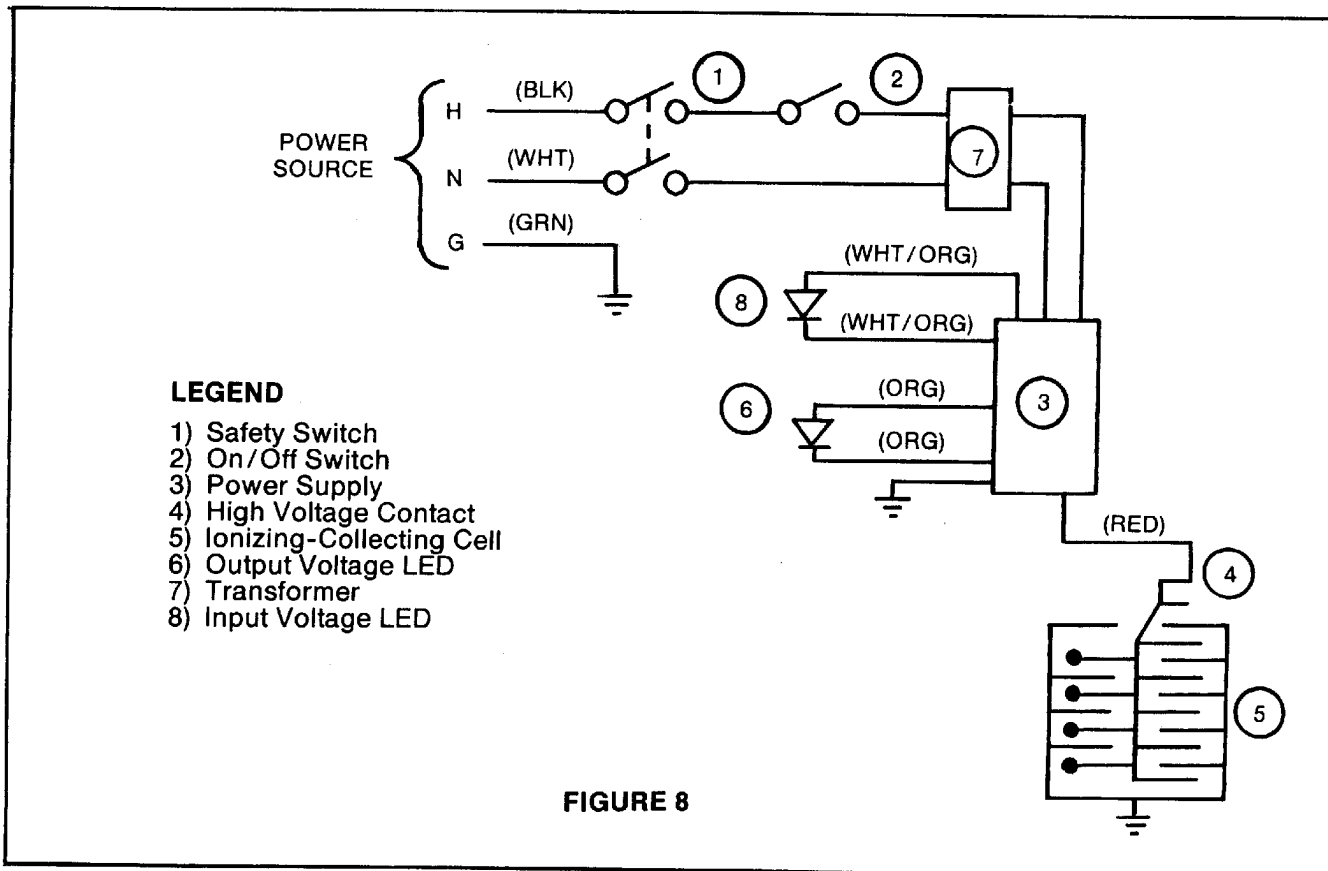

**FIGURE 8**

- b. Check for loose wires; if loose wire found, reconnect.
- c. If defective power supply is indicated, replace.

INPUT: The electronic air cleaner should be wired to operate only when the system blower is on. The circuit of the power pack is 120 volts, 60 cycle single phase.

OUTPUT: This is a high frequency solid state circuit designed for electronic air cleaners with high performance reliability.

- $6.8 \pm .3$  KVDC (with cell connected)
- $8.5 \pm .8$  KVDC (without cell connected)

**B. Other Troubles — Their Symptoms and Corrections**

**1. Arcing Noise**

When an arcing noise is noted, it is usually located in the DC high voltage circuit. The ionizing-collecting cell is part of this circuit and normally the trouble will be found to be in the cell. The noise is caused by high voltage arcing to ground.

An occasional arcing noise is normal and inherent in all precipitators. These occasional arcs are caused by large particles of dirt in the air such as a cigarette ash, insect, etc. Constant or repeated intermittent arcing should be checked.

Check For:

- a. Loose ionizing wire(s) - repair or replace
- b. Excessively dirty cell components - clean
- c. Damaged (bent) plates of ionizer - straighten or replace
- d. Defective or loose high voltage lead or contact assembly - repair, replace
- e. Cracked insulator - replace
- f. Improper ground - check ground and correct if necessary

**2. Hissing Noise**

A hissing noise (or frying sound) usually stems from a loose high voltage connection or from an improper ground. The reduction in the designed spacing usually is caused by bends or deformities in the cell from mishandling.

Check For:

- a. Damaged (bent) plates or ionizer - straighten or replace.

- b. Loose ionizing wires - repair or replace.
- c. Dirty cell or large piece of foreign material between plates - clean.
- d. Defective high voltage contact assembly - repair or replace.
- e. Poor connection between cell and contact assembly - repair.
- f. Loose high voltage wiring - repair.
- g. Improper ground - check ground and correct if necessary.

**3. Humming Noise**

The ionizing wires have a normal tendency to vibrate when charged. On some occasions, when atmospheric conditions are just right and the humidity is exceptionally low, the vibration is aggravated to the point where an audible hum can be noted. It is usually noted more in the northern sections of the country during the winter months. This condition can be further aggravated if the ionizing-collecting cell is very dirty. The condition is self-correcting when the relative humidity is increased or can be alleviated by washing the cell.

**4. Radio and/or Television Interference**

This trouble is not common but when occurring is usually due to either a continuous high voltage "leak or discharge", or from the absence of a good common electrical ground. Refer to checks listed under 1. Arcing Noise and 2. Hissing Noise.

**5. White Dust**

One of the most difficult service calls to handle is the complaint of the presence of white dust. The majority of these complaints are from residential users. In many instances, the statement is made, "We have more dust now than we ever had." These service calls are difficult because the limitations of the installation must be explained.

White dust actually can be described as "clean dirt". Where it is noticed, an examination will show the user that it is largely lint. It is most noticeable on dark furniture, and is usually found in homes containing new furnishings such as carpeting, drapes, etc., which give off more lint than such items that have been used and cleaned for some time. The amount of lint generated is increased by activity in the area; especially by children, pets and heavy house traffic.

Visible lint particles, like cigarette ashes, are heavy as compared to the extremely small, individual dirt particles which make up cigarette smoke. Their weight causes the lint particles to "fall out" on furniture, floors, etc., just as cigarette ashes fall to the floor while cigarette smoke particles remain suspended in the air. Dirt particles, such as heavy pieces of lint or ash, which do not remain airborne, never reach the electronic air cleaner and the unit cannot remove these air particles which never reach the collecting elements.

Fortunately, the black, greasy dirt particles with the damaging staining power are light in weight, remain in the airstream, and do reach the electronic air cleaner. It is their removal from the air that keeps the lint clean, and therefore, more visible.

There is no question that the electronic air cleaner is capable of collecting lint in addition to other atmospheric contaminants. This is easily confirmed by examining the air entering side of the ionizing-collecting cell before it is washed. You will note that along with the black, greasy dirt collected, there are lint particles that did stay airborne long enough to reach the electronic air cleaner.

Lint from new furnishings will decrease with wear. The length of time depends on the amount and type of fabric in the furnishings and the air circulation. In some areas, a bedroom for example, a lint condition will always remain.

Normally, continuous fan operation (24 hours a day) will minimize this problem. If this cannot be accomplished, the controls should be set as near continuous fan operation as possible. In some instances the use of a two speed fan motor is advantageous.

Cold air returns should not be restricted in any manner, particularly from rooms in which lint is prevalent. If the returns in these rooms are blocked, the return air will seek another, longer path. In traveling a greater distance, lint fallout is increased.

Actually, the presence of large, clean lint particles are further proof that the air cleaner is doing its superior air cleaning job. Electronic air cleaners are dependent on the movement of air currents to bring the dirt particles to the unit for their removal. Weighty, non-airborne particles such as cigarette ashes weigh too much to remain in the air currents while other particles, such as cigarette smoke, remain suspended and are carried to the electronic air cleaner for removal.

## 6. Ozone

Under normal operating conditions all electrostatic air cleaners produce minute quantities of ozone as an incidental by-product, as do televisions and other electrical appliances. The design of the unit has been tested and is far below the published permissible limits. The level of detection (when noticed) varies from individual to individual, so being more susceptible than others.

Usually a new unit will produce more ozone than one that has been in operation for several weeks. This is due to the normal amount of sharp corners or manufacturing burrs on the ionizing-collecting cell. The voltage working on these areas however tends to round them off, thereby they are self-correcting.

An ionizing-collecting cell that has been damaged where the designed spacing between electrical charged and ground components has been increased, may also produce an abnormal amount of ozone.

Check For:

- a. Damaged (bent) plates - straighten or replace
- b. Loose ionizing wires - repair or replace
- c. Dirty cell - clean
- d. Loose high voltage connections - repair or replace
- e. Unit "ON" when system fan is not running - set fan for continuous operation or wire so unit will operate only when system fan is running.

## IX. MAINTENANCE AND WASHING

### STEPS FOR WASHING (Ceiling Installation - See Figure 9)

1. Remove grill face by backing out screws on grill assembly. Grill assembly can also be removed completely by slipping it off at the hinge pins.
2. Turn on/off switch to "OFF".
3. Remove pre-filter by turning tab with left hand while right hand lifts on pre-filter.
4. To remove cell, move left hand cell tab into locked position. Put left hand on cell to support its weight while pushing right hand cell tab to the right (open position). **Be prepared to accept the weight of the cell (11 pounds). After cell clears right hand tab, remove cell.**

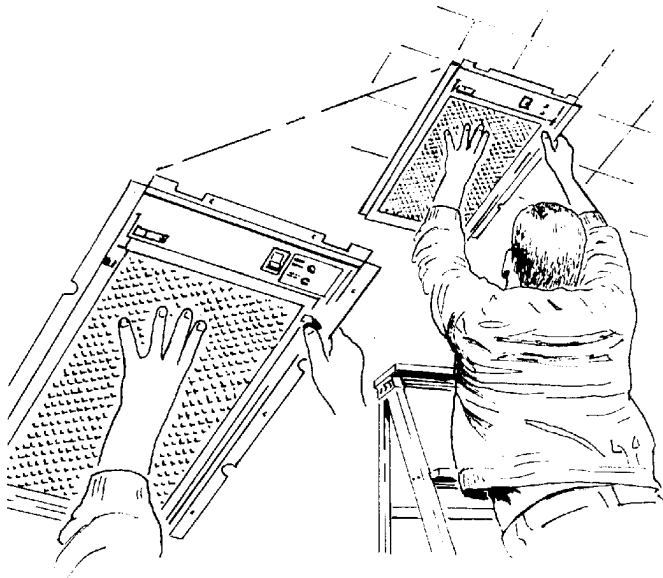

**Figure 9**

### 5. Washing Cell and Pre-Filter

Regular washing is necessary to insure proper performance. A thorough washing once every two months will be adequate for most installations. More frequent washings (once a month) may be necessary on some installations (new homes for example) where there is new carpeting, plaster dust, or there is above normal cigarette smoke, etc.

#### a. To wash in a tub

1. Place enough hot water in a utility tub to cover the cell.
2. Dissolve 2 to 4 oz. of automatic dishwasher detergent (not laundry detergent) in the water.

#### b. Soaking

1. Lay cell on its side in the container and allow to soak for 30 minutes. Repeat with second cell.
2. Then "slosh" cell up and down in the solution until it appears clean. Remove cell from the container.
3. Next "slosh" the pre-filter up and down in the solution until it appears clean. Drain out dirty water.

#### c. Rinsing

1. Hold cell upright in container.
2. With a hose, rinse with warm water.
3. Hose should be held about 10-in. from cell plates and at a slight angle for better cleaning results. Rinse both sides until water runs clear.

4. Thoroughly rinse the cell frame along the edges to dislodge any trapped dirt or lint. Carefully wipe a damp cloth along the ionizing wires.

5. Stand cells and pre-filter up to drain. Wait about two hours to dry.

#### d. To wash in dishwasher

1. Cells and pre-filter may be washed together or one at a time in an automatic dishwasher if they can fit without damaging the ionizing wires on the cells.
2. Use normal amount of automatic dishwasher detergent (powder form).
3. Repeat washing if necessary.

**NOTE:** It is possible that the contaminants on the cell plates could temporarily stain the inside of your dishwasher. If the tub of your dishwasher has a plastic lining you should consider washing the cells in a sink or a wash tub.

6. Replace collection cell. Cells are keyed to insure high voltage contacts on top, and ionizing wires on front.
7. Replace pre-filter.
8. Turn on/off switch to "ON".
9. Replace grill.

### STEPS FOR WASHING (Wall Installation)

1. Remove grill face by backing out screws on grill assembly. Grill assembly can also be removed completely by slipping it off at the hinge pins.
2. Turn on/off switch to "OFF".
3. Remove pre-filter by turning tab, and lifting pre-filter out of the rack.
4. To remove cell, move left hand cell tab into lock position, and lift cell while holding right hand cell tab to the right. After cell clears right hand tab, remove cell.

#### 5. Washing Cell and Pre-Filter

Regular washing is necessary to insure proper performance. A thorough washing once every two months will be adequate for most installations. More frequent washings (once a month) may be necessary on some installations (new homes for example) where there is new carpeting, plater dust, or there is above normal cigarette smoke, etc.

**a. To wash in a tub**

1. Place enough hot water in a utility tub to cover the cell.
2. Dissolve 2 to 4 oz. of automatic dishwasher detergent (not laundry detergent) in the water.

**b. Soaking**

1. Lay cell on its side in the container and allow to soak for 30 minutes. Repeat with second cell.
2. Then "slosh" cell up and down in the solution until it appears clean. Remove cell from the container.
3. Next "slosh" the pre-filter up and down in the solution until it appears clean. Drain out dirty water.

**c. Rinsing**

1. Hold cell upright in container.
2. With a hose, rinse with warm water.
3. Hose should be held about 10-in. from cell plates and at a slight angle for better cleaning results. Rinse both sides until water runs clear.
4. Thoroughly rinse the cell frame along the edges to dislodge any trapped dirt or lint.

Carefully wipe a damp cloth along the ionizing wires.

5. Stand cells and pre-filter up to drain. Wait about two hours to dry.

**d. To wash in dishwasher**

1. Cells and pre-filter may be washed together or one at a time in an automatic dishwasher if they can fit without damaging the ionizing wires on the cells.
2. Use normal amount of automatic dishwasher detergent (powder form).
3. Repeat washing if necessary.

**NOTE:** It is possible that the contaminants on the cell plates could temporarily stain the inside of your dishwasher. If the tub of your dishwasher has a plastic lining you should consider washing the cells in a sink or a wash tub.

6. Replace collection cell. Cells are keyed to insure high voltage contacts on top, and ionizing wires on front.

7. Replace pre-filter.

8. Turn on/off switch to "ON".

9. Replace grill.

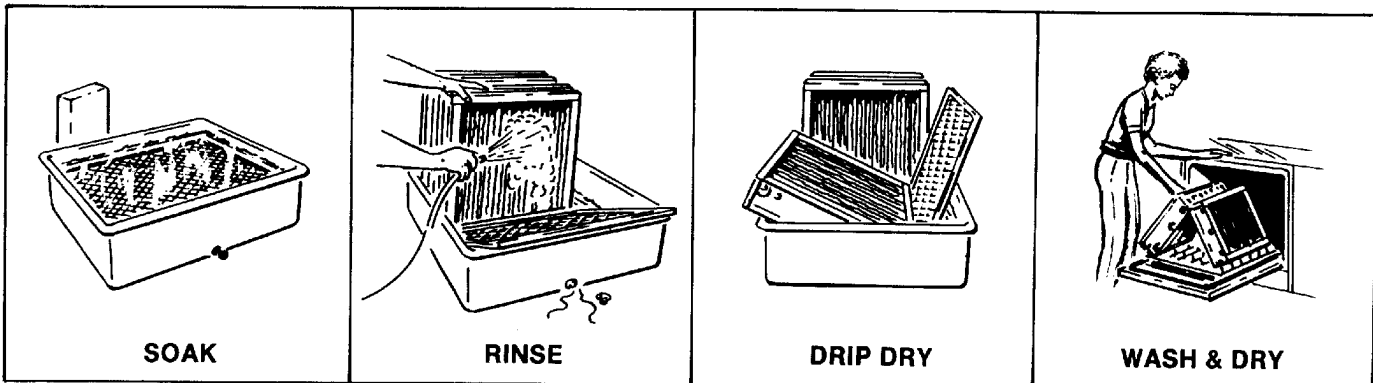

**X. ORDERING PARTS**

When ordering replacement or spare parts, state the Unit Model No. and Serial Number. These numbers are shown on the data plate located on the cabinet housing.

Complete parts list are available upon request. Orders will be filled in accordance with the terms and conditions of current price sheets.

A return material request form must accompany all return parts.

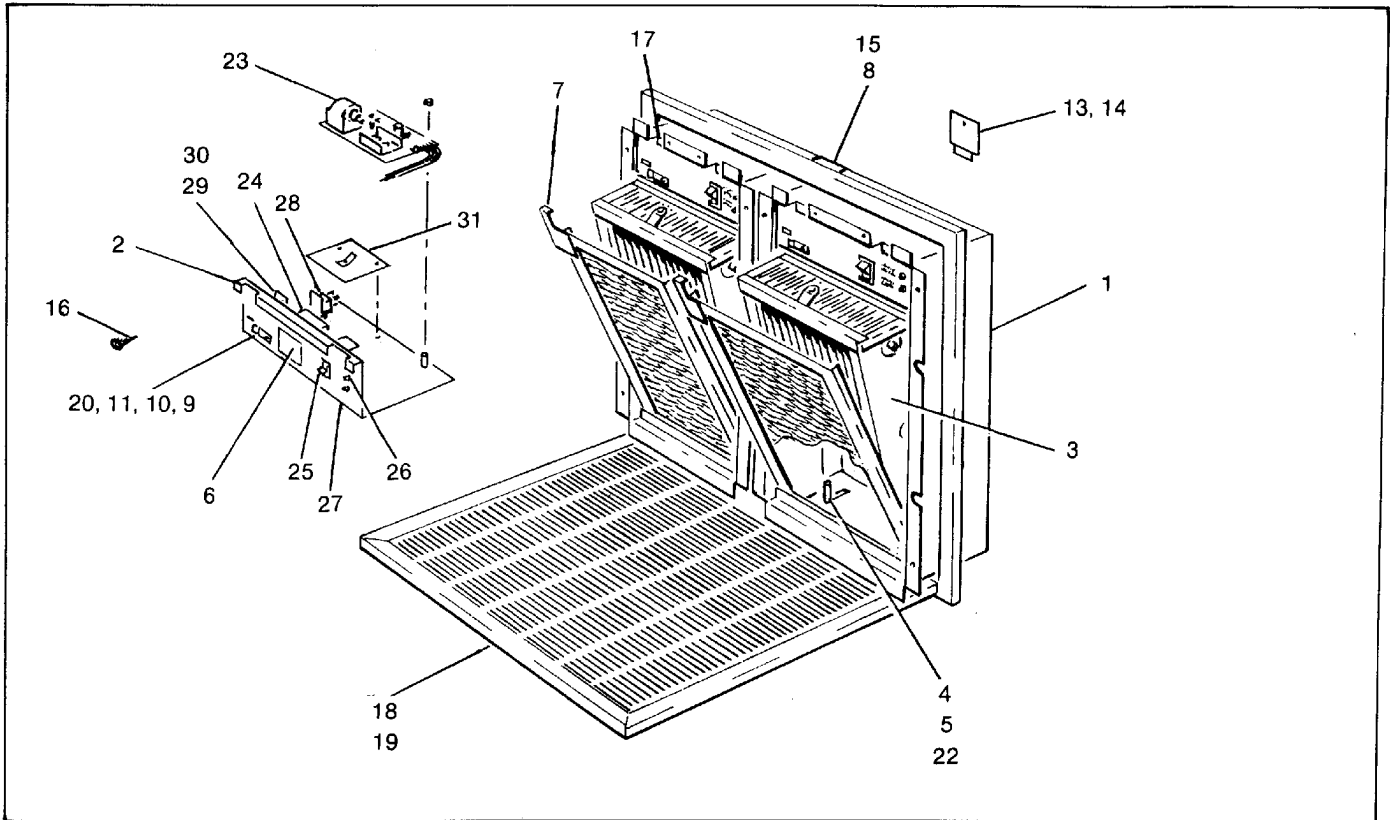

**XI. PARTS LIST**

220111-029

ITEM	PART NO.	DESCRIPTION	ITEM	PART NO.	DESCRIPTION
1	440656-001	Air Cleaner Module	16	122841-204	Sheet Metal Screw
2	440663-001	Power Supply Ass'y.	17	220831-007	Self-Retaining Fastener
3	422086-501	Ionizer-Collector Cell	18	433620-001	Grill Ass'y. (For TGM 1000)
4	126452-011	Spacer	19	433620-002	Grill Ass'y. (For TGM 2000)
5	137060-213	Machine Screw	20	120031-009	Washer
6	140665-001	Data & Warning Label	21	140841-001	Cell Latch Cover (Not Shown)
7	240728-001	Filter Frame Ass'y. (Pre-filter)	22	140840-001	Speed Nut Latching Type
8	240664-001	Divided Support	23	338749-401B	Circuit Board Power Supply
9	140639-001	Pre-filter Latch	24	240669-001	Transformer 24/120
10	137060-406	Machine Screw	25	138586-001	On/Off Switch
11	123149-008	Elastic Stop Nut	26	134516-009	Input Power LED
12	140643-001	Plug Connector (Not Shown) Wiring Compartment	27	134516-008	Output Power LED
13	240852-001	Wiring Access Cover	28	140960-001	Plug Connector
14	135738-301	Sheet Metal Screw	29	132311-001	Safety Interlock Switch
15	135738-302	Sheet Metal Screw (For 2000 Insert)	30	132122-001	Push Button Cap
			31	240646-001	Contact Board Ass'y.