

ER150C and ER200C Perfect Window™ Fresh Air Ventilation Systems

OWNER'S MANUAL

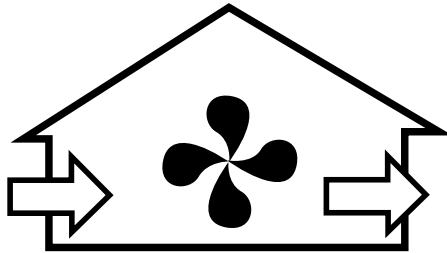

M11706



TABLE OF CONTENTS

Introduction3

Feeling right at home3

The Perfect Window™ Fresh Air Ventilation System consists of3

Operating your Fresh Air Ventilation System4

Getting the most from your Fresh Air Ventilation System6

Maintenance Instructions for your Fresh Air Ventilation System6

Perfect Climate® Control9

Troubleshooting10

Warranty11

Introduction

We take it for granted that our homes will protect us from the elements, but because of tighter, better quality home construction, our indoor environment may be exposing us to unacceptable levels of the very things we are trying to escape. Excessive heat, dryness, humidity, toxic gases and dust contaminants can be sealed in securely by weatherproofing.

So what's the forecast for indoors?

Today's indoor forecast is stormy weather for many homeowners. But rapid clearing and fresh breezes are just around the corner!

Feeling right at home

Unlike what the outdoors brings us, you can have control of indoor conditions. Temperature, humidity levels and air quality can all affect physical health, mental attitude, general comfort and energy savings. With today's technological advances, you can achieve a "Perfect Climate" indoors.

After all, people look to their homes as a place to escape the stress of work, a busy lifestyle and an increasingly polluted outdoor environment. Creating a perfect indoor climate is becoming critical to feeling right at home.

The Honeywell Perfect Window™ Fresh Air Ventilation System removes stale, unhealthy air and replaces it with a stream of fresh air. Its powerful centrifugal blowers bring fresh air into your home and at the same time, exhaust stale air in an equal amount. Both incoming and outgoing airstreams pass through a energy transfer core where both the heat and the moisture from the exhaust air are efficiently transferred to the incoming fresh air. An air duct system supplies the fresh air brought in by the Perfect Window™ ventilator and distributes it throughout your home. Another duct draws the existing stale, air back to the Perfect Window™ ventilator and then exhausts it outdoors.

It's really very simple...and remarkably effective!

The Perfect Window™ Fresh Air Ventilation System consists of...

1. Air Circulation FAN and Motor

Inside the casing are two fans, one for exhaust and one for fresh air supply. The electric motor that operates the fan is 1/15 hp to 1/20 hp (depending on the ventilator model) and uses the same amount of power as a 100 watt lightbulb.

2. Air Filters

There are two permanent washable air filters in your ventilator. The filters lower the amount of dust and outside particulates entering the ventilator core and your fresh air supply.

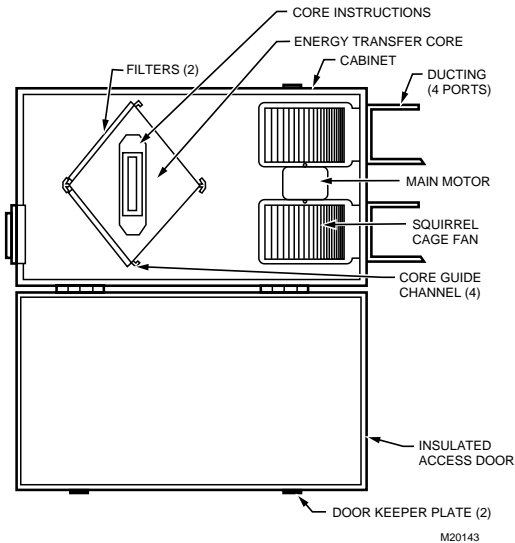

3. Energy Transfer Core

As the exhaust and fresh air pass through opposite sides of the Energy Transfer Core heat is transferred from the warm side to the cold side. This heat transfer reduces the cost of conditioning the fresh outside air that is brought into your home. In addition, moisture is transferred from the wet side to the dryer side. This moisture transfer reduces the drying of the air inside your home that occurs during the winter months and reduces the amount of moisture that is brought into your home during the summer months. The core removes easily for cleaning.

4. Controls - Speed Control

Easy operation, simply rotate the Perfect Window™ ventilator fan speed control to your desired setting.

Operating your Fresh Air Ventilation System

Changing Fan Speed

The control fan speed is conveniently located on the ventilator. The rotary fan speed control knob can be manually set from the off (standby) position through speeds 1 to 4. Note the fifth speed (high) is accessible only by a remote control.

Off/standby mode may be used if intermittent ventilation is desired. In the off/standby position, the ventilator will not function until energized by a remote control, see information below.

It is up to the individual homeowner to set their system to a speed which they find comfortable. If you feel your house is stuffy or there is an above average occupancy rate, you may need to increase your ventilation. In most applications a low to medium speed setting is comfortable.

Connecting a Remote Device

Your ventilator comes equipped with a low voltage terminal strip for connection to several optional control devices.

PERFECT CLIMATE COMFORT CENTER™ CONTROL

The Honeywell Perfect Climate Comfort Center™ unit controls your ventilator automatically by using the programmed times or manually by pressing the Ventilate key. See the Perfect Climate Comfort Center™ Owner's Guide (form 69-0891) for complete instructions.

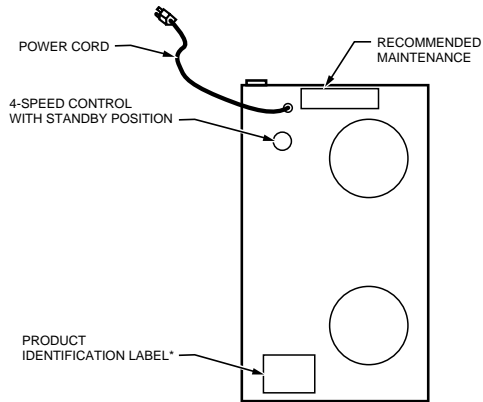

*NOTE: THIS INFORMATION IS VERY IMPORTANT WHEN MAKING INQUIRIES ABOUT YOUR ERV. M11704A

TIMER

For your convenience, Honeywell provides an optional timer control that can fit a wide variety of needs, for example, exhaust humid air from the bathroom or kitchen (see the timer instructions for selection and part numbers).

WALL SWITCH

A wall switch can also be used to switch your ventilator fan speed to high. The fan will run at high speed until the wall switch is turned off.

When any remote device is activated the ventilator will run at high speed. All remote devices must be in the off position to return the fan to the speed manually selected on the rotary fan speed control knob.

Getting the most from your Fresh Air Ventilation System

HOW MUCH VENTILATION DO I NEED?

During the seasons that your windows and doors are closed (winter and summer if you have air conditioning), the ventilator should operate continuously when the home is occupied, and either continuously or intermittently when not occupied.

For most installations, the ventilator will normally be set to operate continuously on low speed with the option of going to high speed as the need arises. For example, if you are entertaining and there is a large number of people present (some may be smoking), the ventilator should be switched to high speed.

YOUR VENTILATOR MAY BE SET TO HIGH SPEED BY:

1. selecting the highest speed on the ventilator or
2. if the system includes an optional remote control, switch it to the ON position.

Maintenance Instructions for your Fresh Air Ventilation System

WARNING

Electrical Shock Hazard.

Can cause personal injury or equipment damage.

Disconnect power supply before performing maintenance.

The Perfect Window™ Fresh Air Ventilation System must be maintained on a regular basis for best efficiency. Honeywell recommends that the ventilator be cleaned and checked at least twice a year, preferably at the beginning of each heating and cooling season.

Check and Clean

EXTERIOR HOODS

Exterior hoods should be inspected at least once a month. Be sure exhaust and fresh air supply hoods are not blocked up or restricted by leaves, grass or snow. In winter, it is especially important to make sure snow is not blocking the hoods or that frost has not built up on the wire mesh (bird screen).

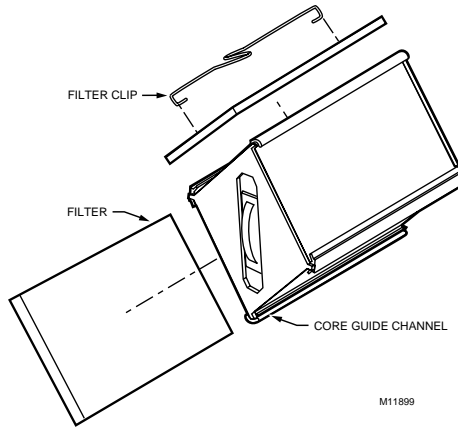

⚠ WARNING

Carbon Monoxide Hazard.

Can cause personal injury or equipment damage.

Hood blockage can cause a change of pressure in building which can lead to possible spillage from combustible appliances.

AIR FILTERS

Air filters should be cleaned twice a year. The standard filters supplied with your ventilator are removable and washable.

1. Open access door and slide out core. Refer to Core Maintenance section for cleaning instructions.
2. Remove filter clip.
3. Remove filters from the core and rinse with water or a combination of soap and water. Do not clean in a dishwasher.
4. After cleaning, place filters (wet or dry) back in their position and reattach the retaining clip.

CORE

IMPORTANT

Do not wash the core with water or other fluids.

Clean the core twice each year using only a vacuum cleaner.

1. Open the access door and carefully grip the ends of the core and pull evenly outward. The core can be snug, but it will slide out of the cabinet.

NOTE: Do not handle the fins because damage can occur.

2. Once out of the cabinet, remove the filters (refer to Air Filter Maintenance section).
3. When the core is dry, clean it with only a vacuum cleaner. Vacuum the filter sides of the core by pulling any dirt back out of the core, not by pulling dirt all the way through the core.
4. Reinstall the clean filters.
5. Reinstall the clean core.

TO INSTALL THE CLEAN CORE:

1. First mount the bottom core guide into the bottom Core Guide Channel.
2. Mount either side core guide, followed by the other side.
3. Mount the top core guide into the top Core Guide Channel.
4. With all four corners in place and the core straight and even, push on the core center until the core slides to the back of the cabinet.

NOTE: The core is designed to appear to protrude from the cabinet approximately 1/8 in. (3mm) so the access door fits tightly against the core.

GENERAL MAINTENANCE

Twice a year, wipe the inside of the cabinet with a damp cloth to remove dirt, bugs and debris that can be present.

FANS

If the fans accumulate dirt, it could cause an imbalance and excessive vibration of the ventilator. A reduction in air flow can also occur. In a newly constructed house, this often happens within the first year due to heavy dust residue in the entire system. It can also occur periodically depending on the outdoor conditions. If you suspect that service is required, please contact the ventilator installer or your local HVAC contractor.

Perfect Climate® Control

Describing Perfection

The most convenient, most energy efficient, cleanest, healthiest and most comfortable indoor environment, possible today! Perfect climate is achieved when the six core components of your homes climate system work together:

- optimal efficiency of heating and cooling equipment
- precise, programmable temperature control
- effective indoor air quality control
- controlled humidity
- proper ventilation and air distribution
- zone control for personalized room-to-room temperature control.

Products for a Perfect Climate® Home

HEATING AND COOLING SYSTEM

This is the workhorse of your indoor climate system. Have your local heating/cooling contractor tune up your system annually for comfort, safety and most economical operation. If your heating equipment is old, think about replacing it with a modern and improved unit. Recent advances in product technology have substantially increased efficiency of equipment. Improved performance often pays back much of the cost of installation within a few short years.

- Honeywell Perfect Window™ Fresh Air Ventilation System
- Honeywell Perfect Climate Comfort Center™ control or Chronotherm® IV programmable thermostat.
- Honeywell F35 media air cleaner or F50 electronic air cleaner.
- Honeywell humidistat and humidifier.
- Honeywell digital fan timer.

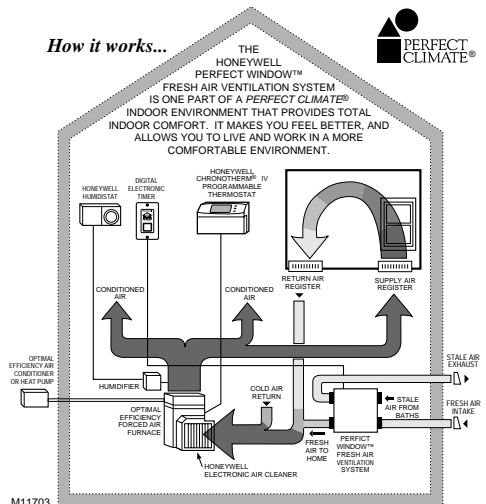

Troubleshooting

Lack of power to the ventilator:

- power failure of electrical box.
- loose or unplugged power cord.
- faulty breaker or fuse in home's electrical panel.
- call your installation contractor.

Power to the ventilator, but no fan operation:

- ventilator is in standby mode and optional remote dehumidistat is set to OFF or the humidity setting is higher than room humidity.
- door is not closed properly, the safety interlock switch will keep the ventilator off. Check that the access door is firmly closed and latched.
- refer to operating instructions.
- call your installation contractor for service.

Lack of Speed Control:

- let the remote device continue its time setting or manually adjust it to gain speed control.
- test the speed control on the ventilator by turning the variable speed control knob to its highest setting.
- call your installation contractor for service.

Limited Warranty

Honeywell warrants this product, to be free from defects in the workmanship or materials, under normal use and service, for a period of one (1) year from the date of purchase by the consumer. If, at any time during the warranty period, the product is defective or malfunctions, Honeywell shall repair or replace it (at Honeywell's option) within a reasonable period of time.

If the product is defective

- (i) return it, with a bill of sale or other dated proof of purchase, to the retailer from which you purchased it, or
- (ii) package it carefully, along with proof of purchase (including date of purchase) and a short description of the malfunction, and mail it, postage prepaid, to the following address:
Honeywell Return Goods
Dock 4, MN10-3860
1885 Douglas Drive North
Golden Valley, MN 55422

This warranty does not cover removal or reinstallation costs. This warranty shall not apply if it is shown by Honeywell that the defect or malfunction was caused by damage which occurred while the product was in the possession of a consumer.

Honeywell's sole responsibility shall be to repair or replace the product within the terms stated above. HONEYWELL SHALL NOT BE LIABLE FOR ANY LOSS OR DAMAGE OF ANY KIND, INCLUDING ANY INCIDENTAL OR CONSEQUENTIAL DAMAGES RESULTING, DIRECTLY OR INDIRECTLY, FROM ANY BREACH OF ANY WARRANTY, EXPRESS OR IMPLIED, OR ANY OTHER FAILURE OF THIS PRODUCT. Some states do not allow the exclusion or limitation of incidental or consequential damages, so this limitation may not apply to you.

THIS WARRANTY IS THE ONLY EXPRESS WARRANTY HONEYWELL MAKES ON THIS PRODUCT. THE DURATION OF ANY IMPLIED WARRANTIES, INCLUDING THE WARRANTIES OF MERCHANTABILITY AND FITNESS FOR A PARTICULAR PURPOSE, IS HEREBY LIMITED TO THE ONE YEAR DURATION OF THIS WARRANTY. Some states do not allow limitations on how long an implied warranty lasts, so the above limitation may not apply to you.

This warranty gives you specific legal rights, and you may have other rights which vary from state to state.

If you have any questions concerning this warranty, please write Honeywell Customer Relations, 1885 Douglas Drive North, MN10-1461, Golden Valley, MN 55422. In Canada, write Honeywell Limited/Honeywell Limitée, 35 Dynamic Drive, ON15, Scarborough, Ontario M1V 4Z9.

Honeywell

Automation and Control Solutions

Honeywell
1985 Douglas Drive North
Golden Valley, MN 55422

Honeywell Limited-Honeywell Limitée
35 Dynamic Drive
Scarborough, Ontario
M1V 4Z9

59-1563-1 G.H. Rev. 01-02



Printed in U.S.A. on recycled
paper containing at least 10%
post-consumer paper fibers.

www.honeywell.com/yourhome