

This Owner's Manual is provided and hosted by [Appliance Factory Parts](#).



# WINDCHASER WDH928 Owner's Manual

[Shop genuine replacement parts for WINDCHASER  
WDH928](#)



[Find Your WINDCHASER Dehumidifier Parts - Select From 11 Models](#)

----- Manual continues below -----



---

# INSTRUCTION MANUAL

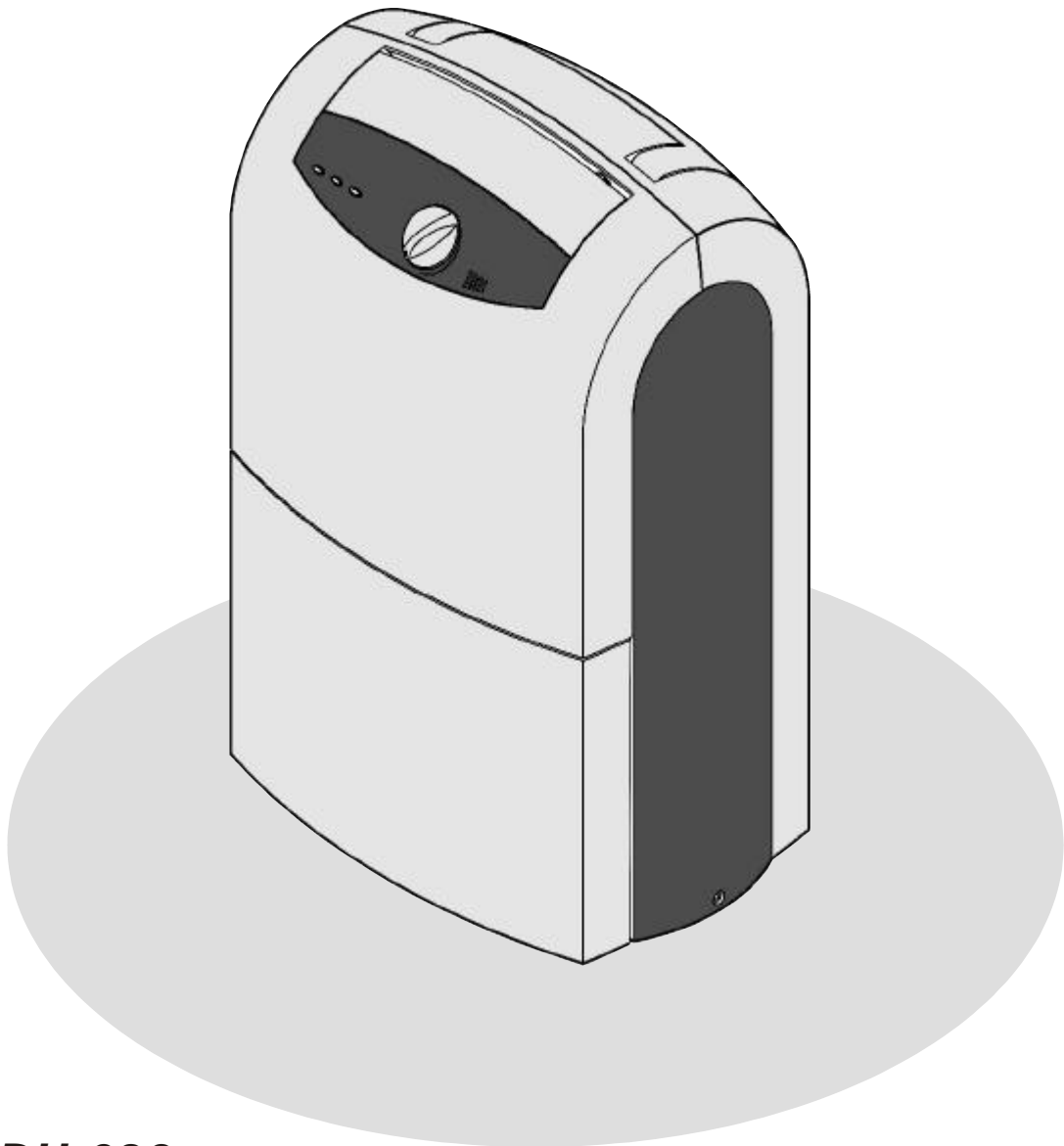

***Model: WDH-928***

Please read this manual before use.

Caution: Operate only with 115V, 60Hz current

## BEFORE INITIAL USE

Attach your purchase receipt here

For your reference:

Serial No. \_\_\_\_\_ Date of Purchase \_\_\_\_\_

Name and Address  
of Dealer

---

---

---

---

## UNPACKING INSTRUCTIONS

1. Place the unit in an upright position before unpacking.
2. Carefully lift the unit out of the box.
3. Save ALL packaging for off season storage.
4. The unit must always be used in an upright position because it contains a cooling agent.
5. After unpacking, place the unit upright to allow the cooling agent to stabilize, and wait 3 hours before use.

# SAFETY INSTRUCTIONS

## READ AND SAVE THESE INSTRUCTIONS

When using electrical appliances basic precautions should always be followed including the following:

- Do not damage the power cord.
- Never lay down the unit while it is working.
- Always keep unit in an upright position to avoid any damage to the cooling system.
- Operate this unit in an ambient temperature of 90° or lower.
- Be sure that the air inlets and outlets are not blocked or covered up.
- Never place anything on top of the unit and do not cover it with any kind of cloth while it is plugged in or in-use.
- This unit is designed for use only in a house, office and similar conditions and it should not be used for any other purpose.
- Never connect the unit to a defective socket.
- This unit needs at least 5 Amps of electricity to start its compressor.
- Check your breaker box to determine which circuit the socket is on.
- Make sure that the unit is correctly connected before turning on the unit's power.
- Never unplug the unit while it is working. This could damage the electronic circuits.
- To avoid tripping the circuit, **DO NOT USE AN EXTENSION CORD FOR THIS UNIT.**
- To turn on your unit, always use the switch on the control panel.
- It is dangerous to modify or to change the characteristics of the unit.
- Prevent children from climbing on the unit.
- Do not place the unit near curtains (minimum distance 1.5 ft.).
- Do not place the power cord under a carpet.
- Never install the unit in direct sunshine or in the rain.
- When used for the first time, and every time it is turned on, it takes the unit up to 3 minutes to be operational.
- This appliance has a polarized plug (one blade is wider than the other). To reduce the risk of electric shock, this plug is intended to fit in a polarized outlet only one way. If the plug does not fit fully in the outlet, reverse the plug. If it still does not fit, contact a qualified electrician. Do not attempt to defeat this safety feature.
- Keep the area around the warm air outlet sufficiently clean and make sure that it is not congested.
- For any repairs, refer directly to our customer service department. Repairs carried out by unqualified people may cause damage or may even be dangerous and void the warranty.

**Any damage resulting from failure to comply with these instructions is excluded from the Warranty.**

# Component

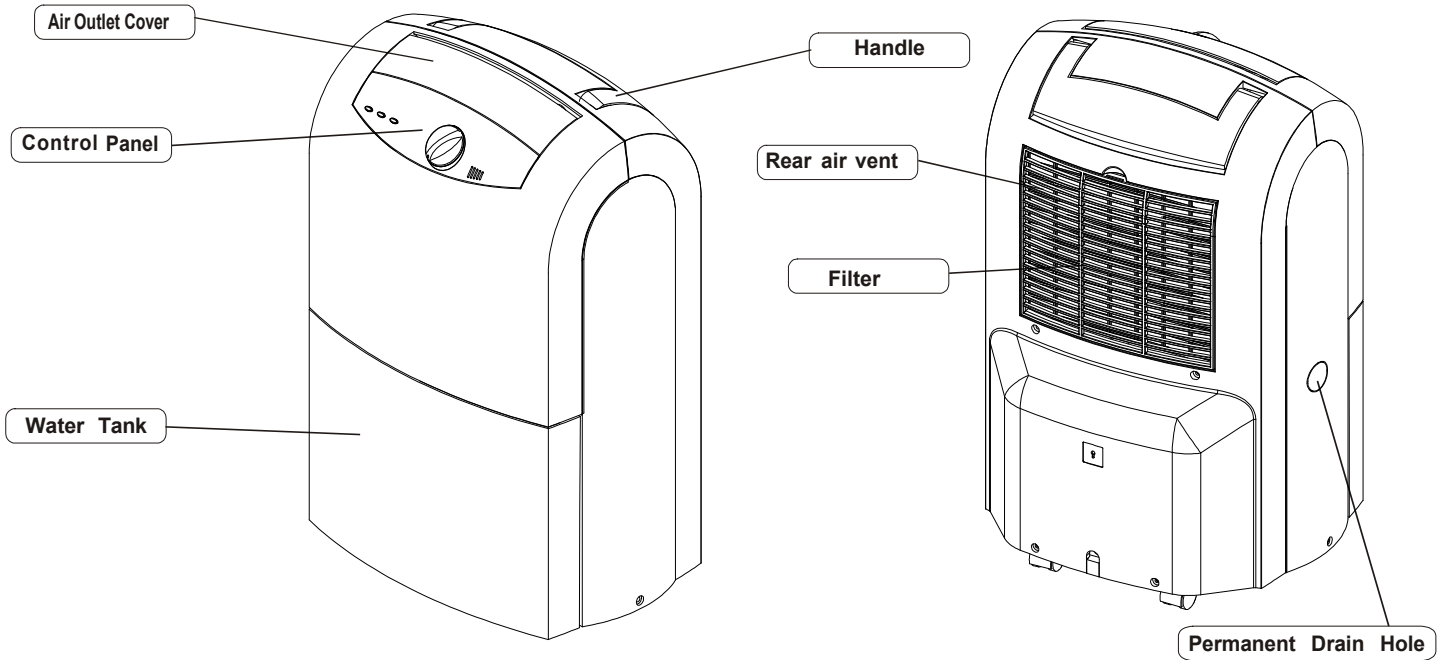

# Operating guide

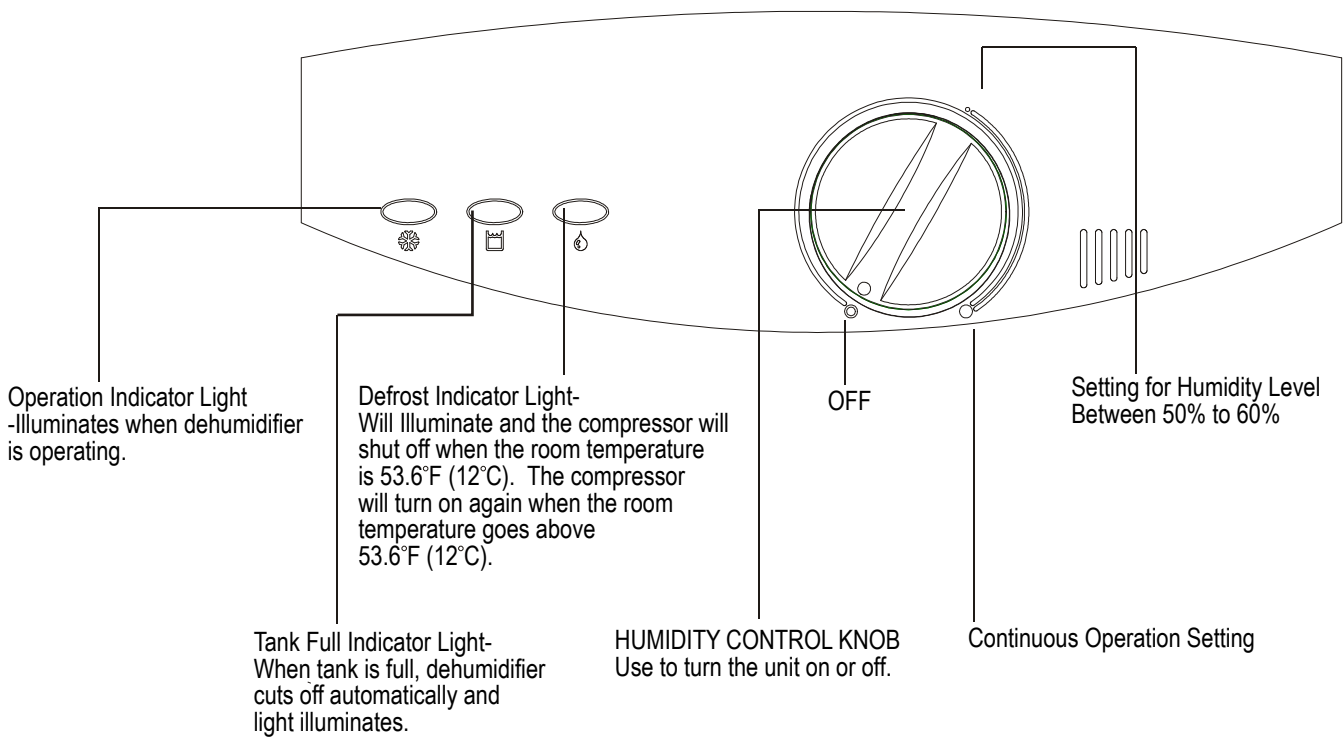

## Operation

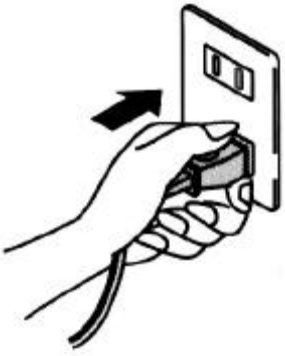

- Insert the power plug securely.

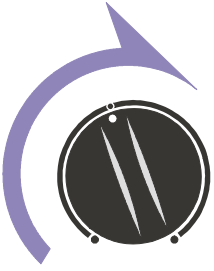

- Rotate the humidity dial to the desired setting, and the dehumidifier will automatically come on if the humidity level inside the room exceeds the selected setting.
- Upon reaching the desired humidity level, the dehumidifier will automatically stop.
- The dehumidifier will automatically turn back on once the humidity level exceeds the selected setting.

## Emptying the Water Tank

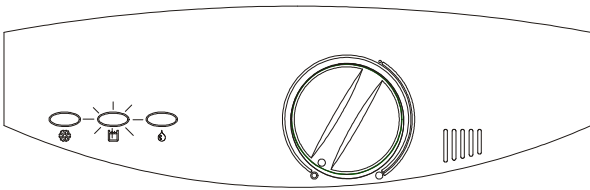

- When the water tank is full, the indicator light will illuminate and the dehumidifier will automatically shut off.

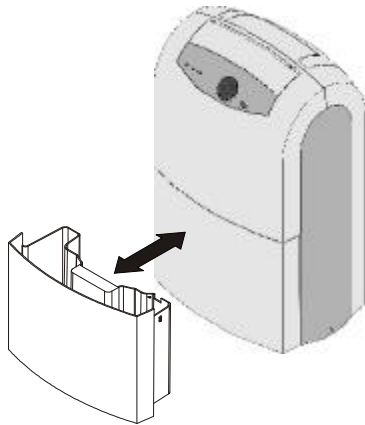

- Remove the water tank, empty water, place tank back in unit and unit will return to operation mode.

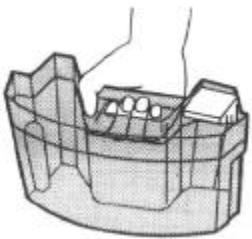

- Hold the water tank by the handle as shown.



- Hold the tank by the sides with both hands to empty the water.

# Hooking up a Continuous Drain Hose:

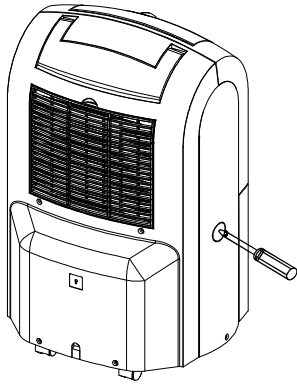

- For continuous drainage via gravity, use a flexible PVC tube approx. 0.5 inches (1.3cm) in diameter, commonly found at home furnishing stores, cut to the required length.
- Lightly tap open the drain hole on the left of the housing.

- Insert the flexible PVC tube into the drain hole on the unit.

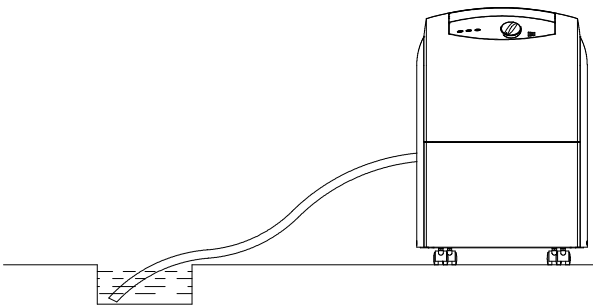

- When using the continuous drain feature, make sure the drain tube is laid flat horizontally and fastened in place; avoid overlapping or depressing, and make sure it lays lower than the drain hole.

## Safety precaution:



Never handle any power cord with wet hands.

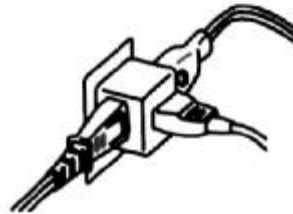

Refrain from using multiple power outlets to avoid electrical sparks.

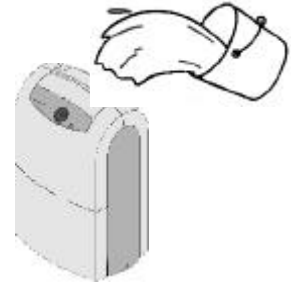

Keep the unit and control panel free of contact with moisture.



Never pull from the power cord to avoid electrical shorts.

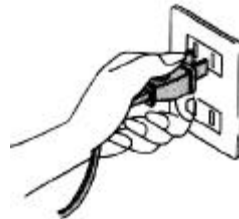

For optimal safety, remove the power cord and turn off the unit whenever cleaning or servicing is required.



Refrain from disassembling or servicing the unit, unless by a trained service technician.

## Warning:

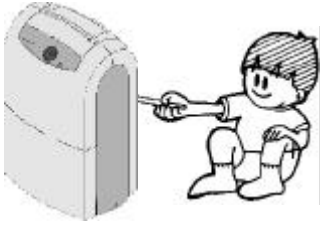

Never insert any foreign objects into the unit to avoid hazards.



Keep all combustibles, such as gasoline, away from the unit.



Keep the electrical plug clean at all times.



Never drape clothing over the dehumidifier for drying.



Never spray insecticide or apply grease paint near the unit to avoid damage to the plastic parts and to avoid fire hazards.

## Operating precaution:

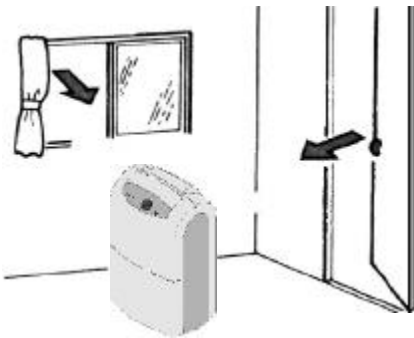

Refrain from leaving the door or windows open to maximize dehumidifying efficiency.

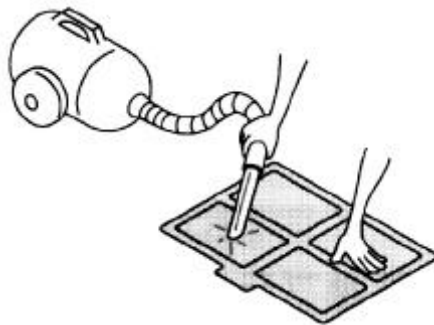

Clean the filter regularly to ensure maximum air intake and dehumidifying efficiency.

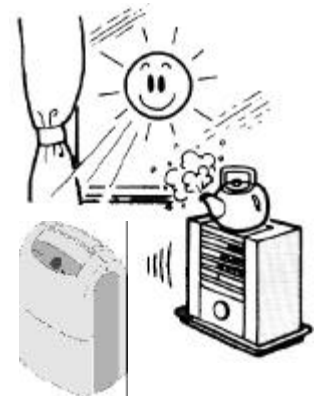

Keep the unit away from all heat sources to prevent the plastic parts from damage, which may lead to hazards.

## Operating precaution:



Refrain from operating the dehumidifier near the sink.

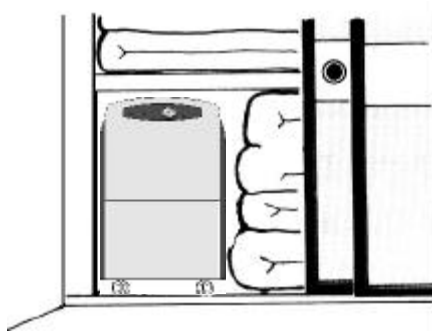

Refrain from operating the dehumidifier in a confined closet.

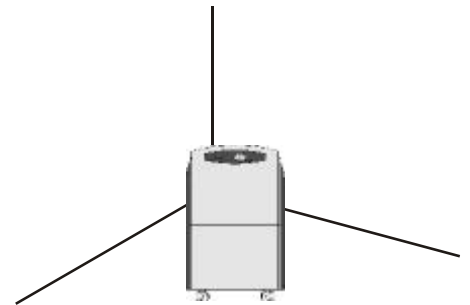

Allow adequate clearance around all sides of the dehumidifier.

## Maintenance tips:

Always make sure the power plug has been removed prior to maintenance or repair.

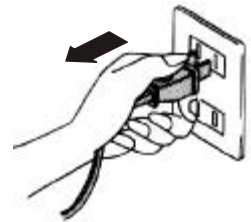

### 1) Caring for housing:

- A. Use a soft, clean rag to wipe the surface of the dehumidifier.
- B. For dust buildup, a mild cleansing agent may be used to gently wipe clean the surface. Wipe off the agent with tap water.
- C. Never rinse the unit with water.

### 2) Cleaning the air filter:

The air filter serves to filter out the dust or odor in the air. Under normal operating conditions, clean the filter on a biweekly basis by removing the filter and vacuuming the dust.

## Emergency Handling:

In the event the dehumidifier should malfunction or emit strange odors, please remove the plug immediately, and contact WindChaser Customer Service (see Warranty); do not attempt to disassemble the unit to avoid electrical hazards.

## Electrical specifications

<b>Model</b>	<b>WDH-928</b>
<b>Current feed</b>	<b>115V, 60Hz</b>
<b>Dehumidifying Capacity</b>	<b>30 PINTS 80.6° F 60%RH (27° C 60%RH)</b>
<b>Power rating</b>	<b>570 watts</b>
<b>Dimensions (WxHxD)</b>	<b>15.35 in x 24.09 in x 12.36 in (39.0 cm x 61.2 cm x 31.4 cm)</b>
<b>Gross weight</b>	<b>46.29 lbs. (21 kgs)</b>
<b>Applicable operating range</b>	<b>41°F - 95°F (5°C - 35°C)</b>

**If the power supply cord is damaged, please contact WindChaser Customer Service.**

# PRODUCT LIMITED WARRANTY

This warranty applies to new product only and excludes optional accessories and attachments. Extended compressor warranty applies only to product with manufacturing dates beginning January 1, 1998.

During the first year from the date of original purchase, this product is warranted to be free from defects in materials or workmanship under normal use, service and maintenance. During the 2nd through 5th years from the date of original purchase, the compressor (part only) is warranted against defects in material or workmanship under normal use, service and maintenance.

This warranty applies to the original purchaser subject to the following terms and conditions:

**WHAT IS COVERED:** The product's components as originally installed by the manufacturer that are defective in materials or workmanship under normal use, service and maintenance.

**WHAT IS NOT COVERED BY THIS WARRANTY:** This warranty does not extend to or cover:

- (1) Any defect due to the negligence of others; failure to install, operate or maintain unit or accessories and attachments in accordance with installation instructions (instruction manual is furnished with each new unit); unreasonable use; accidents; alteration, use of unauthorized or non-standardized parts, accessories and attachments; acts of God; theft; vandalism; blown fuses; electrical malfunction. (i.e., as resulting from power surges, shorted or overloaded circuits outlets of wiring utility power quality, etc.), incorrect installation; use of any power source other than that specified on the Product's specification label; or repair by anyone other than a service facility specified by an authorized **WINDCHASER** representative.
- (2) Diagnostic, troubleshooting and travel costs.
- (3) Operation and usage orientation costs.
- (4) Performance or operation certification and testing costs.
- (5) Normal wear and tear of parts including but not limited to, hoses, cables, accessories and attachments.
- (6) Shipping, handling, packaging and delivery costs of the product, parts or accessories.
- (7) Shipping, handling and freight damages.
- (8) Diagnosing, repairing, removing, installing, shipping, servicing and/ or handling costs of either defective parts or replacement parts as relating to Extended 4 Year Compressor Warranty.

**WHO IS COVERED** The original purchaser from a retailer or licenced air conditioning contractor.

**WHAT WE WILL DO:** During the first year, **WINDCHASER** will either repair or replace, at its option, all defective product components free of charge that are covered by this Limited Warranty on a carry-in basis to the authorized **WINDCHASER** repair facility. During the second through fifth years, **WINDCHASER** at its option, will provide a new or remanufactured compressor (part only) free of charge as covered by this Limited Warranty on a carry-in basis to the authorized **WINDCHASER** repair facility.

**WHAT YOU MUST DO FOR WARRANTY SERVICE:** You must return the defective Product to your authorized **WINDCHASER** repair facility along with a copy of the bill of sale or credit card charge receipt or other document evidencing the date of original purchase and the product's model number.

Before returning this product, call for troubleshooting assistance. If you purchased the unit from a retailer, contact **WindChaser** Products customer service at 1-800-405-2943 for assistance. If you purchased this unit from an air conditioning wholesaler or contractor, please contact them first for assistance; if they are unable to assist you, contact **WINDCHASER**.

Do not return the unit, components or parts to **WINDCHASER** without prior written approval and return authorization from **WINDCHASER**.

You are responsible for prepaying all shipping, handling, packaging and delivery costs to and from the warranty repair center. **WINDCHASER**, its dealers, distributors and representatives are not responsible for damage resulting from improper packing and or mishandling by a shipper.

THE FOREGOING EXPRESSES ALL OF **WINDCHASER'S** OBLIGATIONS AND LIABILITIES WITH RESPECT TO THE QUALITY OF PRODUCT, ITS COMPONENTS, ACCESSORIES AND ATTACHMENTS FURNISHED. ALL OTHER WARRANTIES, EXPRESS OR IMPLIED, INCLUDING THE WARRANTIES OF MERCHANTABILITY OR FITNESS FOR A PARTICULAR PURPOSE ARE DISCLAIMED. **WINDCHASER** SHALL NOT BE LIABLE FOR THE LOSS OF USE OF THE PRODUCT, ITS COMPONENTS, ACCESSORIES AND ATTACHMENTS, INCONVENIENCE, LOSS OR ANY OTHER DAMAGES, DIRECT OR CONSEQUENTIAL ARISING OUT OF THE USE OF, OR INABILITY TO USE THE PRODUCT, ITS COMPONENTS AND ACCESSORIES OR DAMAGES RESULTING FROM OR ATTRIBUTABLE TO DEFECTS IN THE PRODUCT, ITS COMPONENTS AND ACCESSORIES.

NO ONE OTHER THAN **WINDCHASER** HAS AUTHORITY TO EXTEND OR MODIFY THE TERMS OF THIS LIMITED WARRANTY IN ANY MANNER WHATSOEVER.

Some states do not allow the exclusion or limitation of incidental or consequential damages or limitations on how long an implied warranty lasts, so these limitations or exclusions may not apply to you. This limited warranty gives you certain legal rights and you may also have other rights specific to your country, state or province.

**This warranty is valid only in the United States and Canada.**



WindChaser Products, Inc.  
4130 Del Rey Avenue, Marina Del Rey, CA 90292  
(800) 405-2943, 310-827-8615  
Fax: 310-827-8566  
E-Mail: [customerservice@windchaserproducts.com](mailto:customerservice@windchaserproducts.com)