

Dehumidifier

SERVICE MANUAL

**MODELS: DH300E/DH304
LD40/DH400M/GD40E
DH404E/DH400E/LD40E
DH504EL/LD50EL
LD65EL**

CAUTION

- BEFORE SERVICING THE UNIT,
READ THE SAFETY PRECAUTIONS IN THIS MANUAL.
- ONLY FOR AUTHORIZED SERVICE.

CONTENTS

1. PREFACE

1.1 SAFETY PRECAUTIONS	3
1.2 FEATURES AND DIMENSIONS	3
1.2.1 FEATURES.....	3
1.2.2 DIMENSIONS	3
1.3 MODEL NAMES	4
1.4 SPECIFICATIONS	4
1.5 CONTROL TYPE	5
1.5.1 MECHANICAL TYPE	5
1.5.2 ELECTRONIC TYPE	5
1.6 HOW TO OPERATE DEHUMIDIFIER	6
1.6.1 HOW DOES THE DEHUMIDIFIER WORK?	6
1.6.2 LOCATION FOR THE DEHUMIDIFIER.....	6
1.6.3 MICRO SWITCH.....	6
1.6.4 AUTO DEFROST.....	6
1.6.5 HUMIDITY CONTROLLER.....	7
1.6.6 DRYER	7

2. CIRCUIT DIAGRAM

8

3. DISASSEMBLY INSTRUCTIONS

3.1 MECHANICAL PARTS	13
3.1.1 BUCKET AND AIR FILTER	13
3.1.2 FRONT CASE AND TOP COVER.....	13
3.1.3 CABINET AND CONTROL BOX	13
3.2 CONTROL PARTS	14
3.2.1 POWER CORD ASSEMBLY	14
3.2.2 SENSOR ASSEMBLY	14
3.2.3 PWB(PCB) ASSEMBLY, MAIN	14
3.2.4 CAPACITOR.....	14
3.2.5 MICRO SWITCH ASSEMBLY	14
3.2.6 COIL ASSEMBLY, SOLENOID	15
3.2.7 CONTROL PANEL	15
3.2.8 FAN AND MOTOR.....	16
3.2.9 DRAIN PAN	16
3.3 REFRIGERATING CYCLE	17
3.3.1 CONDENSER, EVAPORATOR AND CAPILLARY TUBE	17
3.3.2 PTC OR OVERLOAD PROTECTOR (OLP) FOR RECIPROCATING COMPRESSOR	17
3.3.3 ROTARY COMPRESSOR	17
3.4 HOW TO REPLACE REFRIGERATION SYSTEM.....	18

4. TROUBLESHOOTING GUIDE

20

5. EXPLODED VIEWS

22

6. REPLACEMENT PARTS LIST

28

1. PREFACE

This Service Manual provides various service information, including the mechanical and electrical parts. This dehumidifier was manufactured and assembled under the strict quality control procedures. The refrigerant is charged at the factory. Be sure to read the safety precaution prior to servicing the unit.

1.1 SAFETY PRECAUTIONS

- Disconnect the power supply before servicing or replacing any component.
- Do not cut off the grounding prong or alter the plug in any manner.

1.2 FEATURES AND DIMENSIONS

1.2.1 FEATURES

- Quiet operation
- High efficiency
- Adjustable humidistat
- Automatic defrost
- Automatic shut-off
- Bucket-full indicator light
- Easy roll casters
- Removable & large capacity bucket.
- Washable air filter
- Two-speed fan
- Drain hose connection.
- Low temperature operation (DH504EL/LD50EL/LD65EL)

1.2.2 DIMENSIONS (mm/in)

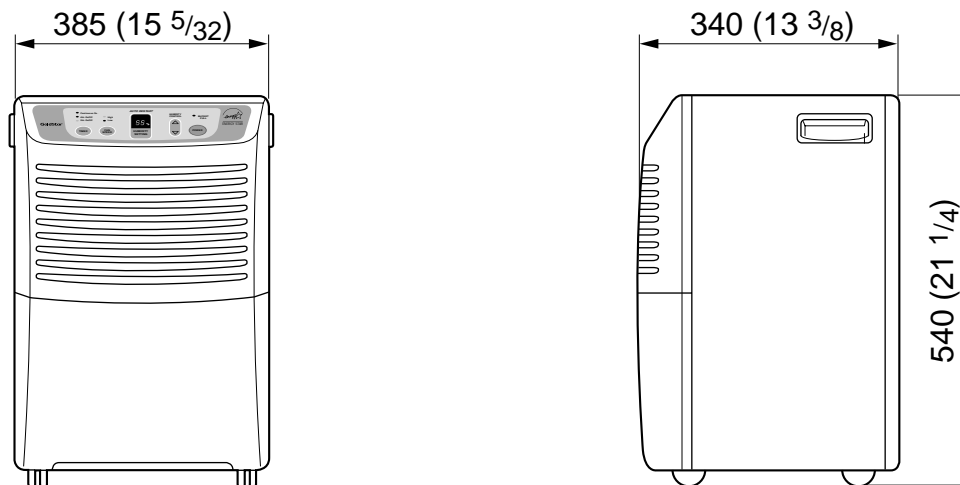

Figure 1

1.3 MODEL NAMES

		MODEL NAME			
CAPACITY (Pints/24hrs)		30	40	50	65
CONTROL PANEL	MECHANICAL TYPE	DH304, DH300M	DH400M,LD40	-	-
	ELECTRONIC TYPE	DH300E	GD40E,DH404E DH400E,LD40E	DH504EL LD50EL	LD65EL

1.4 SPECIFICATIONS

ITEMS		MODELS	DH304, DH300M DH300E	DH400M, LD40 GD40E, DH404E DH400E, LD40E	DH504EL* LD50EL*	LD65EL*
POWER SUPPLY(Phase,V,Hz)		1Ø, 115V,60Hz				
INPUT(W)		480	580	630	830	
RUNNING CURRENT(A)		5.9	5.7	5.7	8.4	
ENERGY FACTOR(L/kw.h)		1.23	1.36	1.56	1.54	
REFRIGERANT		R134a		R22		
REFRIGERANT CHARGE, oz(g)		5.29(150)	4.94(140)	7.23(205)	8.82(250)	
THERMISTOR	OPEN	33.8°F(1±0.5°C)				
	CLOSE	50°F(10±0.5°C)				
SOLENOID VALVE*		-		Using Temp/Humid.:-4~122°F(-20~50°C)/95%RH ↓ Rating:7W/90mA		
COMPRESSOR MODEL No.		LX86HAQG	QS075CBA	QA084CBC	QA114CBD	
P.T.C ASSEMBLY	TYPE		P6R8MC			
	TIME		WORKING TIME:0.3~1.3sec RETURN TIME:65sec			
	MAXIMUM	AMPERE	10A			
		VOLTAGE	200V			
PROTECTOR		OVERLOAD PROTECTOR FOR COMPRESSOR INTERNAL PROTECTOR(FUSE)FOR MOTOR				
CAPACITOR		-	40µF, 270VAC	35µF, 270VAC	35µF, 270VAC	
MOTOR ASSEMBLY,SINGLE		Shaded pole motor, 72W/1.4A, Thermal cutoff:266°F/130°C				Shaded pole motor, 91W/1.8A, Thermal cutoff:266°F/130°C
SWITCH ASSEMBLY,MICRO		15A/250VAC				
OUTSIDED MENSIONS WxHxD,mm(in)		385X540X340(15 5/32 x 21 1/4 x 13 3/8)				
NET WEIGHT,kg(lbs)		23.1(51)	17.7(39)	20.4(45)	22.2(49)	

※ *NOTE:Specifications are subject to minor change without notice for further improvement.

1.5 CONTROL TYPE

1.5.1 Mechanical type

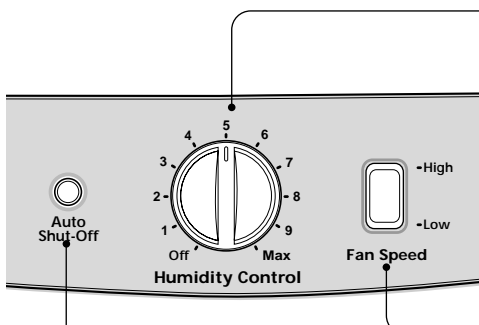

Figure 2

Auto Shut-Off

- This light glows when the bucket is full, or when the bucket is removed or not placed in the proper position. In these cases the Water Level Control Switch shuts off the dehumidifier.
- When the light glows, check the bucket condition.

Humidity Control

- When you first use the dehumidifier, turn the humidity control to 5 or 6. If you still have moisture, turn the humidity control to a higher setting. **MAX** is the highest setting.
- When excess moisture and dampness odors are gone, adjust the control to a lower setting. Use the dehumidifier as long as excess moisture is present.

Fan Speed

- The fan control adjusts the fan speed. Set the fan control to **HIGH** for maximum moisture removal. When the humidity has been reduced and quiet operation is preferred, set the fan control to **LOW**.

1.5.2 Electronic type

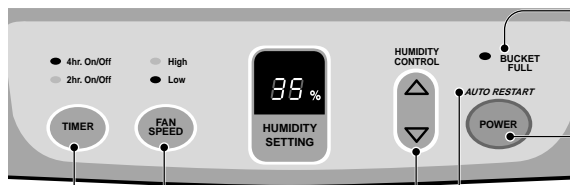

Figure 3

Fan Speed

- This controls the speed of the airflow.
- High: Fan speed is set to high.
- Low: Fan speed is set to low.
- When Fan Speed button is pressed, the fan speed mode is changed.

Timer

- Press this button to select type of operation.
- Select continuous On for uninterrupted operation.
- Select either 2 or 4 hr. On/Off for cycled operation: The unit will operate for 2 or 4 hours, and then shut off completely for 2 or 4 hours. The cycle repeats until you change the setting.
- When Timer button is pressed, the Timer indicator lights shift as follow from 2hr.On/Off to 4hr.On/Off.

Bucket Full Indicator

- This light glows when the water bucket is full and needs to be emptied.

Power

- Operation starts when this button is pressed and stops when the button is pressed again.

Auto Restart

- Once power is restored after a power outage, the unit returns to its previous operation setting after a 2 minute delay. The fan runs immediately when the power is restored.

Humidity Control

- This button controls the humidity in the room.
- Press Δ button to raise the humidity setting.
- Press ∇ button to lower the humidity setting.
- The humidity setting can be set to a permanent "On" setting or to a specific humidity setting between 35% and 70% in 5% increments.
- "On" setting: Dehumidifier runs continuously regardless of humidity condition.
- 35% - 70% setting: Dehumidifier runs on and off according to surrounding humidity conditions.

1.6 HOW TO OPERATE DEHUMIDIFIER

1.6.1 HOW DOES THE DEHUMIDIFIER WORK?

Moist, humid air is drawn over a cold refrigerated dehumidifying coil. Moisture in the air condenses on this coil and drains into a bucket (or through the bucket into a hose and drain).

Dry, clean air is drawn over the condenser where it is actually heated several degrees and discharged out the rear grille into the room. (See Figure 4)

■ *It is normal for the surrounding air to become slightly warmer as the dehumidifier operates.*

This warming effect further reduces the relative humidity of the surrounding air.

1.6.2 LOCATION FOR THE DEHUMIDIFIER

Allow at least 12 inches of space on all sides of the unit for good air circulation. (See Figure 5)

■ *The dehumidifier must be operated in an enclosed area to be most effective.*

■ *Close all doors, windows and other outside openings to the room.*

Place the dehumidifier in a location that does not restrict air flow into the front grille or out the rear grille.

The operation of dehumidifier in a basement will have little or no effect in drying an adjacent enclosed storage area, such as a closet, unless there is adequate circulation of air in and out of the area.

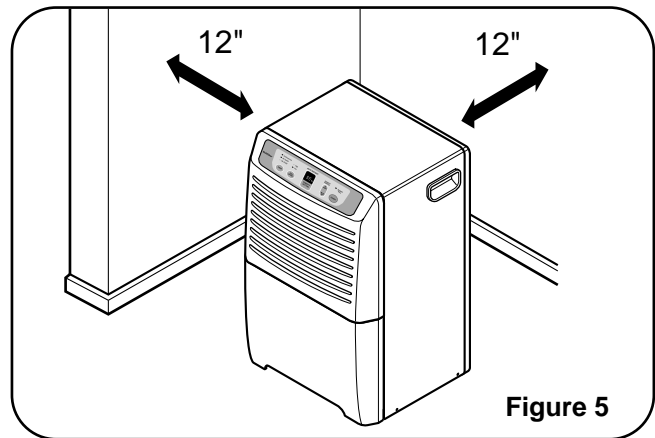
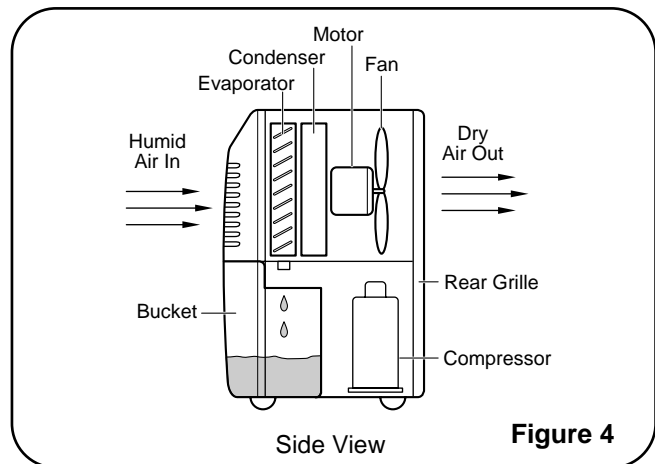

1.6.3 MICRO SWITCH

The micro switch assembly, which is located on the drain pan of inside unit, automatically shuts off the dehumidifier when the bucket is full (note, the Auto Shut Off lights, to indicate bucket must be emptied). The bucket replaces in its place, the unit again turns itself on.

1.6.4 AUTO DEFROST

When frost builds up on the cooling coils, the unit will automatically cycle off until the frost disappears. The fan continues to run.

NOTE: The unit will not operate satisfactorily if the room temperature is below 65°F(18°C). If the dehumidifier is operated in low temperature conditions frost can form in the evaporator coil and the unit will cycle ON/OFF repeatedly. In this case, please check your room temperature conditions and stop the unit.

NOTE: The low temperature operation feature in the DH504EL, DH50EL and DH65EL models will continuously cycle up to a temperature of 42°F(6°C).

1.6.5 HUMIDITY CONTROLLER

1.6.5.1 Mechanical Type

The humidity control can be set anywhere between Off and Max for normal operation.

If you need more dehumidification, turn the Humidity Control toward Max. If you need less dehumidification, turn the Humidity Control toward Off.

The relative humidity range is from 20% to 80%. (See Figure 6)

Turn the Humidity Control to Off to stop the unit manually.

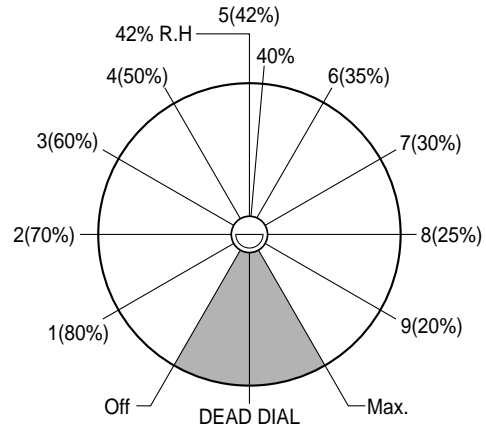

Figure 6

1.6.5.2 Electronic Type

The humidity control can be set 'on' or 35%-70% RH(Relative Humidity) for normal operation. (See Figure 7)

If you need drier air, press the ▽ Humidity Control button.

If you need moister air, press the △ Humidity Control button.

Press the Power button to stop the unit manually.

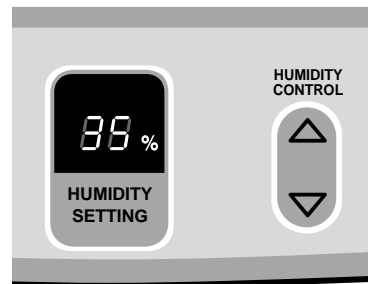

Figure 7

1.6.6 DRYER (DH304, DH300M, DH300E)

Dryer is used to prevent capillary blockage from moisture in the refrigerant system and H/E, condenser and evaporator. Also, dryer is used to remove corrosion of the components.

NOTE: When dryer is replaced, proper injection to capillary is needed. On opening the dryer, it should be welded instantly. The oxidization of dryer inside and all tubes inside after welding can be prevented.

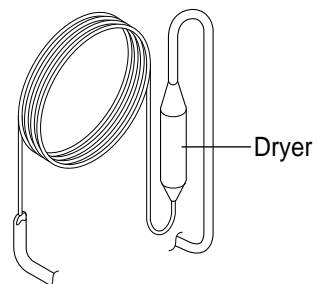
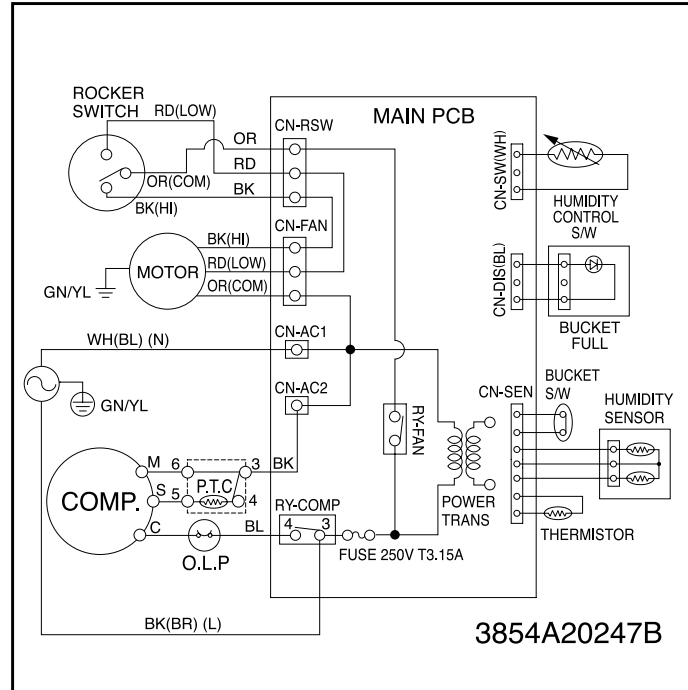

Figure 8

2. CIRCUIT DIAGRAM

• MODEL : DH304, DH300M



NO.	DESCRIPTION	PART NO.	Q'TY PER SET	RE- MARKS
		DH304, DH300M		
1	POWER CORD ASSEMBLY	6411A20001Z	1	S
2	SWITCH, ROCKER	6600FX5001G	1	S
3	MOTOR ASSEMBLY	4681A20040J	1	S
4	PTC ASSEMBLY	6748C-0003D	1	S
5	RE-COMPRESSOR, SET	2521C-A8626	1	S
6	OLP	6750C-0009E	1	S
7	PWB(PCB) ASSEMBLY, DISPLAY	6871A20289B	1	S
8	SENSOR ASSEMBLY	6877A30013L	1	S
9	SWITCH ASSEMBLY, ROTARY	6601A30001B	1	S
10	SWITCH ASSEMBLY, MICRO	6600A30003C	1	S
11	PWB(PCB) ASSEMBLY, MAIN	6871A10142A	1	S

※ S: SERVICE PARTS A: ALTERNATE PARTS N: NOT SERVICE PARTS

• MODEL : DH300E

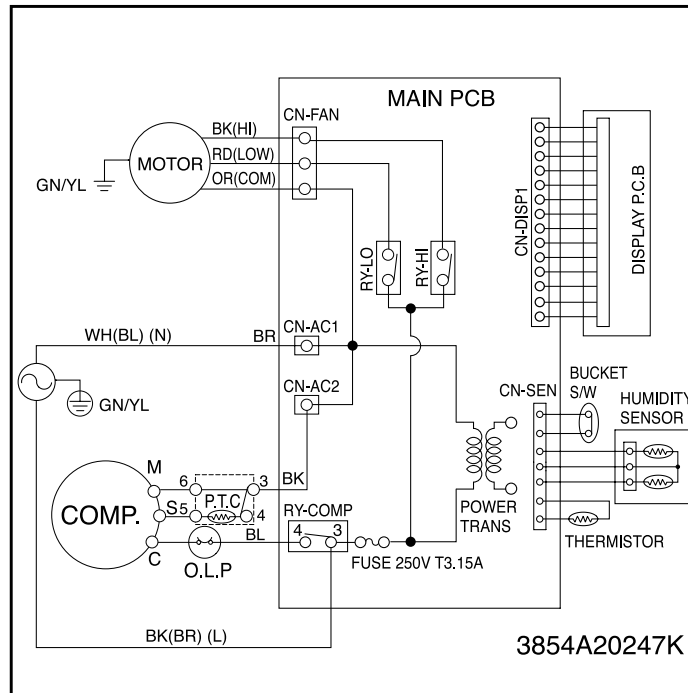

NO.	DESCRIPTION	PART NO.	Q'TY PER SET	RE- MARKS
		DH300E		
1	POWER CORD ASSEMBLY	6411A20001Z	1	S
2	MOTOR ASSEMBLY	4681A20040J	1	S
3	PTC. ASSEMBLY	6748C-0003D	1	S
4	RE-COMPRESSOR, SET	2521C-A8626	1	S
5	OLP	6750C-0009E	1	S
6	PWB(PCB) ASSEMBLY, DISPLAY	6871A20482A	1	S
7	SENSOR ASSEMBLY	6877A30013L	1	S
8	SWITCH ASSEMBLY, MICRO	6600A30003C	1	S
9	PWB(PCB) ASSEMBLY, MAIN	6871A10141A	1	S

※ S: SERVICE PARTS A: ALTERNATE PARTS N: NOT SERVICE PARTS

• **MODEL : DH400M/LD40**

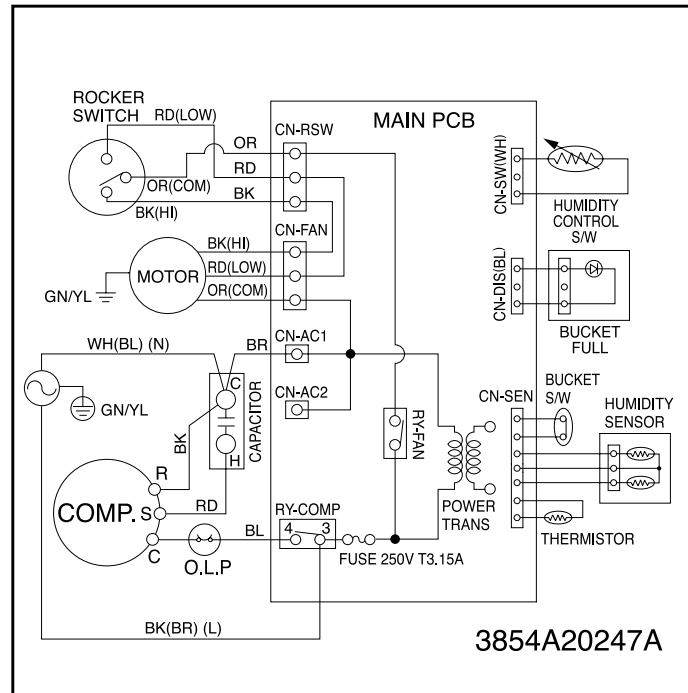

NO.	DESCRIPTION	PART NO.	Q'TY PER SET	RE- MARKS
		DH400M/LD40		
1	POWER CORD ASSEMBLY	6411A20001Z	1	S
2	SWITCH, ROCKER	6600FX5001G	1	S
3	MOTOR ASSEMBLY	4681A20040J	1	S
4	CAPACITOR	0CZZA20005N	1	S
5	COMPRESSOR (ROTARY), SET	2520UCAS003	1	S
6	OLP (ASSEMBLY)	6750U-L103A	1	S
7	PWB(PCB) ASSEMBLY, DISPLAY	6871A20289B	1	S
8	SENSOR ASSEMBLY	6877A30013M	1	S
9	SWITCH ASSEMBLY, ROTARY	6601A30001C	1	S
10	SWITCH ASSEMBLY, MICRO	6600A30003C	1	S
11	PWB(PCB) ASSEMBLY, MAIN	6871A10142A	1	S

※ S: SERVICE PARTS A: ALTERNATE PARTS N: NOT SERVICE PARTS

• **MODEL : GD40E/DH404E/DH400E/LD40E**

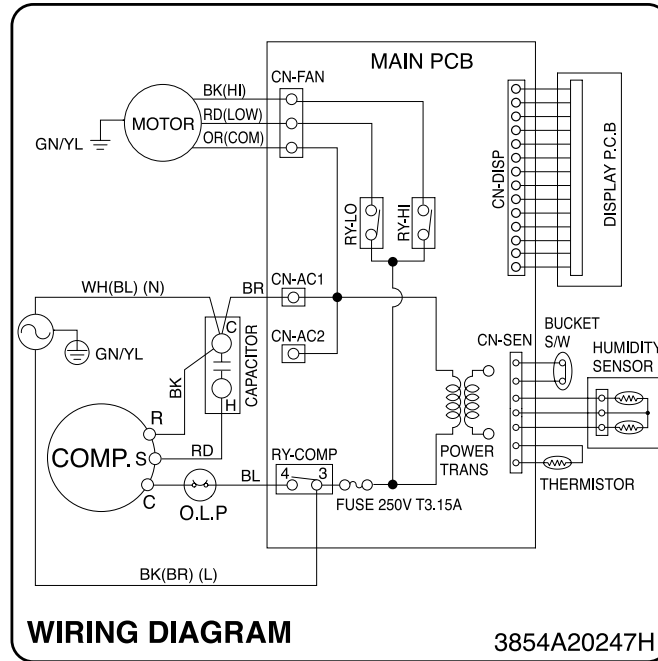

NO.	DESCRIPTION	PART NO.	Q'TY PER SET	RE- MARKS
		GD40E/DH404E/DH400E LD40E		
1	POWER CORD ASSEMBLY	6411A20001Z	1	S
2	MOTOR ASSEMBLY	4681A20040J	1	S
3	CAPACITOR	0CZZA20005N	1	S
4	COMPRESSOR,SET	2520UCAS003	1	S
5	OLP	6750U-L013A	1	S
6	PWB(PCB) ASSEMBLY,DISPLAY	6871A20482A	1	S
7	SENSOR ASSEMBLY	6877A30013M	1	S
8	SWITCH ASSEMBLY,MICRO	6600A30003C	1	S
9	PWB(PCB) ASSEMBLY,MAIN	6871A10141A	1	S

※ S: SERVICE PARTS A: ALTERNATE PARTS N: NOT SERVICE PARTS

• MODEL : DH504EL/LD50EL/LD65EL

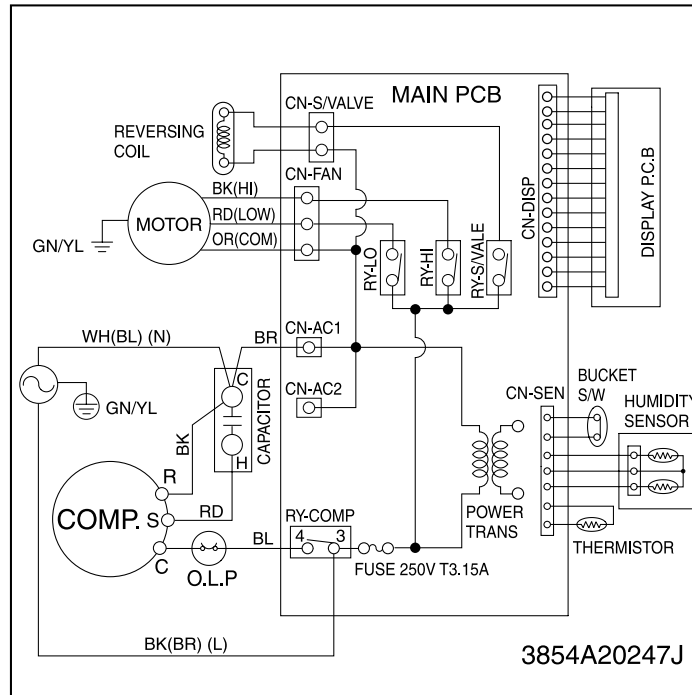

NO.	DESCRIPTION	PART NO.		Q'TY PER SET	RE-MARKS
		DH504EL/LD50EL	LD65EL		
1	POWER CORD ASSEMBLY	6411A20001Z		1	S
2	MOTOR ASSEMBLY	4681A20040J	4681A20040K	1	S
3	CAPACITOR	0CZZA20001R	0CZZA20005J	1	S
4	COMPRESSOR (ROTARY), SET	2520UCAA014	2520UCBA007	1	S
5	OLP.	6750U-L058A	6750U-L048A	1	S
6	PWB(PCB) ASSEMBLY, DISPLAY	6871A20482A		1	S
7	SENSOR ASSEMBLY	6877A30013L		1	S
8	SWITCH ASSEMBLY, MICRO	6600A30003C		1	S
9	PWB(PCB) ASSEMBLY, MAIN	6871A10141C		1	S
10	COIL ASSEMBLY, SOLENOID	6421A20003V		1	S

※ S: SERVICE PARTS A: ALTERNATE PARTS N: NOT SERVICE PARTS

3. DISASSEMBLY INSTRUCTIONS

3.1 MECHANICAL PARTS

3.1.1 BUCKET AND AIR FILTER

1. Turn the Humidity Control off(Mechanical type) or press the power button off. (Electronic type)
2. Disconnect the power supply.
3. Remove the bucket. (See Figure 9)
4. Pull out the air filter. (See Figure 10)

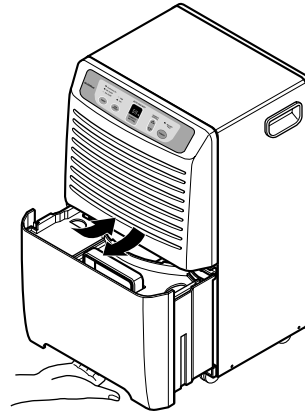

Figure 9

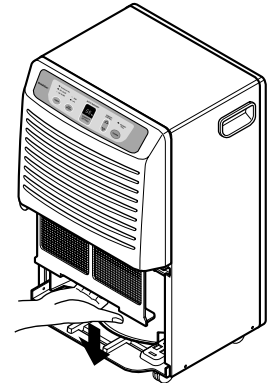

Figure 10

3.1.2 FRONT CASE AND REAR GRILLE

1. Remove 2 screws which fasten the front grille.
2. Pull the front grille forward and upward. (See Figure 11)
3. Remove 6 screws that secure the rear grille.
4. Remove the rear grille. (See Figure 12)

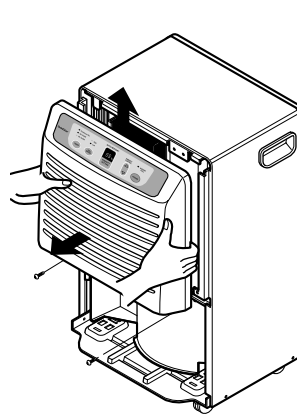

Figure 11

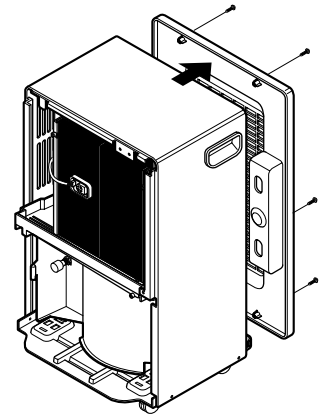

Figure 12

3.1.3. CABINET AND CONTROL BOX

1. Remove the Bucket, the Air filter and Front grille according to the procedure above.
2. Remove 1 screws that fasten Control box. (See Figure 13)
3. Remove 8 screws on all sides of the cabinet.
4. Lift the Cabinet from the base.(See Figure 13)
5. Remove a screw fasten the earth wire on the inside of control box.
6. Remove 1 screw that fasten control box and unhook control box from hook on the shroud. (See Figure 14)

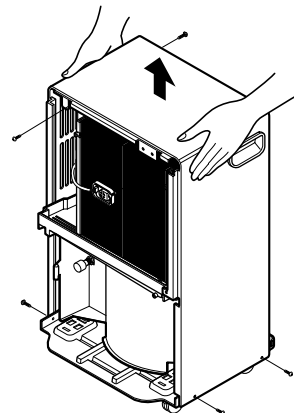

Figure 13

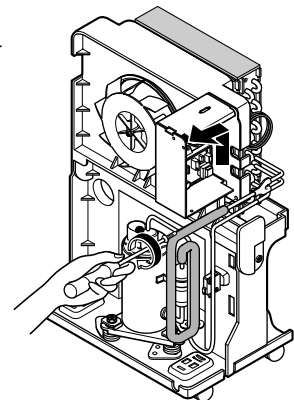

Figure 14

3.2 CONTROL PARTS

3.2.1 POWER CORD ASSEMBLY

1. After opening the control box, remove the screw that holds the ground wire. (See Figure 15)
2. Disconnect the remaining leads of the power cord from the PWB(PCB) ASSEMBLY, MAIN, then remove it from the control box.

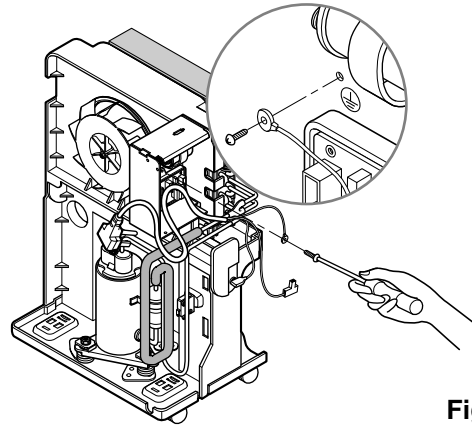

Figure 15

3.2.2 SENSOR ASSEMBLY

1. Disconnect the sensor assembly from the PWB(PCB) ASSEMBLY, MAIN.
2. Remove the screw which fastens the humidity sensor. (See Figure 16)
3. Remove the thermistor from the holder. (See Figure 16)
4. Disconnect the switch wires from the micro switch assembly. (See Figure 16)

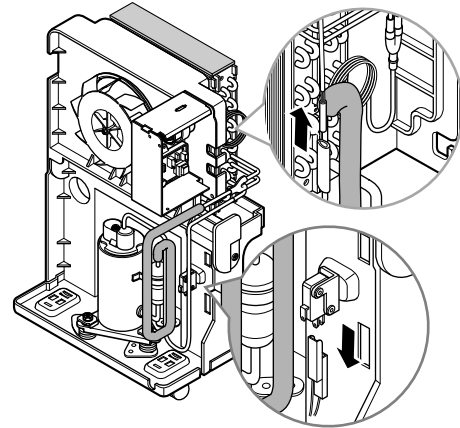

Figure 16

3.2.3 PWB(PCB) ASSEMBLY, MAIN

1. Disconnect all leads of the motor and the compressor from PWB(PCB) ASSEMBLY, MAIN.
2. Remove the screw which fastens the PWB(PCB) ASSEMBLY, MAIN and pull it out after unhooking from 2 rectangular holes of the control box (lower). (See Figure 17)

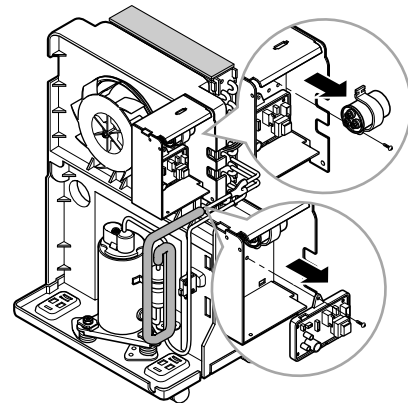

Figure 17

3.2.4 CAPACITOR (Except DH304/DH300M/DH300E)

1. Remove the screw that fastens the capacitor. (See Figure 17)
2. Disconnect all leads from the capacitor and then remove it from control box.

3.2.5 MICRO SWITCH ASSEMBLY

1. Turn the nut counterclockwise and pull out the micro switch from the drain pan. (See Figure 18)

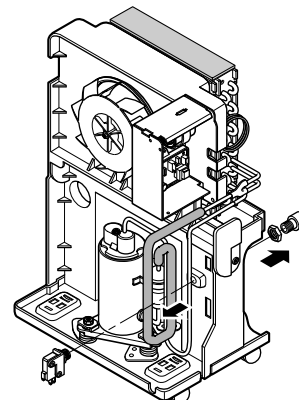

Figure 18

3.2.6 COIL ASSEMBLY, SOLENOID (DH504EL, LD50EL, LD65EL)

1. Disconnect the housing of the COIL ASSEMBLY, SOLENOID from the PCB(PWB) ASSEMBLY, MAIN.
2. Remove the screw that fastens the COIL ASSEMBLY, SOLENOID. (See Figure 19)
3. Pull it out upwards.

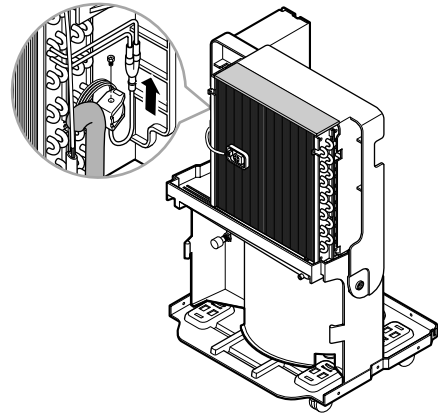

Figure 19

3.2.7 CONTROL PANEL

3.2.6.1 CONTROL PANEL - Mechanical Type (DH304/DH300M/DH400M/LD40)

1. Disconnect housing and all leads of the rocker switch, SWITCH ASSEMBLY, ROTARY and PWB(PCB) ASSEMBLY, DISPLAY from PWB(PCB) ASSEMBLY, MAIN (3.1.3)
2. Pull out the knob assembly.
3. Remove the nut which fastens the SWITCH ASSEMBLY, ROTARY.
4. Remove the knob of the rotary switch by pulling it upward.
5. Pull out the rocker switch by pushing the hooks on the both sides of rocker switch.
6. Pull out the PWB(PCB) ASSEMBLY, DISPLAY after turning over both hooks of the display cover.

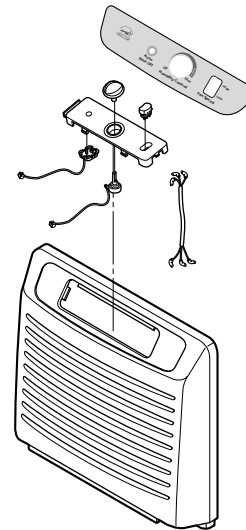

Figure 20

3.2.6.2 CONTROL PANEL - Electronic Type (DH300E/GD40E/DH404E/DH400E/LD40E/DH504EL/ LD50EL/LD65EL)

1. Disconnect the housing of the PWB(PCB) ASSEMBLY, DISPLAY from PWB(PCB) ASSEMBLY, MAIN (3.1.3).
2. Remove 6 screws that secure the PWB(PCB) ASSEMBLY, DISPLAY to the display cover.

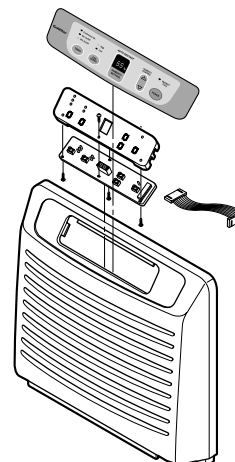

Figure 21

3.2.8 FAN AND MOTOR

1. Turn the nut left and pull out the Fan by hands carefully.
2. Remove 2 screws that fasten Heat Exchange.
3. Lift the H/E and open the H/E around 45 degree clockwise carefully. (See Figure 22)
4. Unfasten 3 screws that secure the Motor and earth wire. (See Figure 23)
5. Remove the Motor.

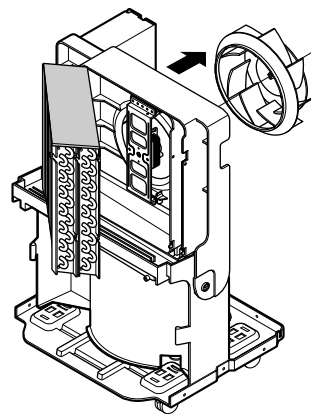

Figure 22

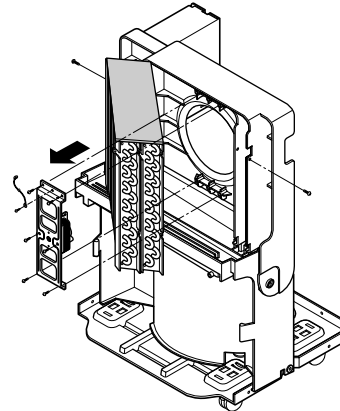

Figure 23

3.2.9 SHROUD AND DRAIN PAN

1. Discharge the refrigerant by using a refrigerant Recovery System.
2. After purging the unit completely, unbrace the Discharge and the Suction tube connected compressor carefully.
3. Remove 2 screws that fasten the H/E.
4. Unfasten 2 screws that secure the shroud on the sides and then lift shroud from the drain pan. (See Figure 24)
5. Unfasten 2 screws that secure the drain pan to base pan. (See Figure 25)
6. Pull the drain pan backward then take it up from the base. (See Figure 25)

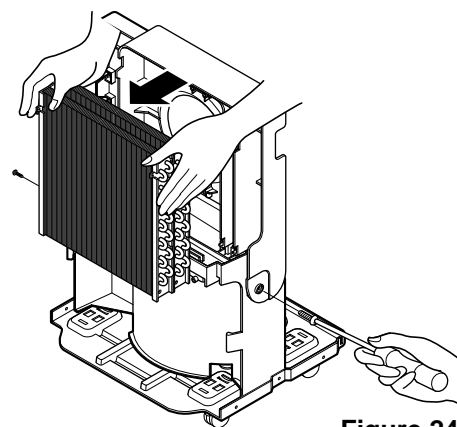

Figure 24

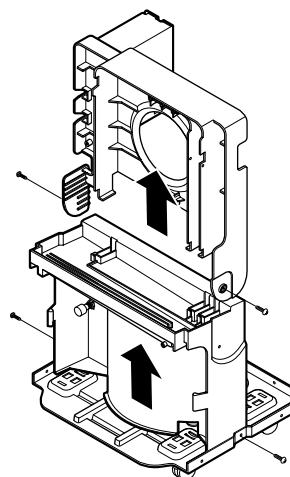

Figure 25

3.3 REFRIGERATING CYCLE

3.3.1 CONDENSER, EVAPORATOR AND CAPILLARY TUBE

1. Remove the insulation on the Heater/Evaporator (H/E) assembly
2. Pierce the pinch-off tube to discharge the refrigerant, using a refrigerant recovery system.
3. After discharging the refrigerant completely, remove 2 screws between the housing assembly and the H/E. (See Figure 26)
4. Lift the H/E and open the H/E around 45 degree counterclockwise carefully.
5. Unbraid each of interconnecting tubes of the evaporator and condenser carefully.
6. Remove the H/E assembly from the orifice. (See Figure 27)
7. Unbraid the capillary tube at the connections of the condenser and evaporator. (See Figure 28)
8. Remove 4 screws between the condenser and evaporator. (See Figure 28)

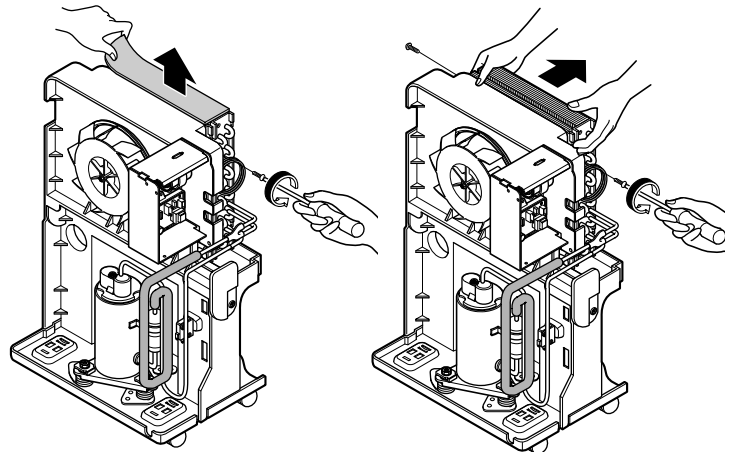

Figure 26

Figure 27

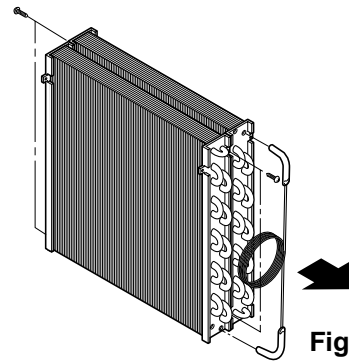
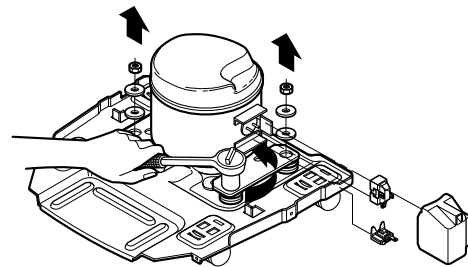

Figure 28

3.3.2 PTC OR OVERLOAD PROTECTOR (OLP) FOR RECIPROCATING COMPRESSOR (DH304/DH300M/DH300E)

1. Discharge the refrigerant by using a refrigerant Recovery System.
2. After purging the unit completely, unbraid the suction and discharge tubes at the compressor connections.
3. Remove the screw or nut which fastens the terminal cover
4. Disconnect the lead wire from the overload protector or PTC assembly.
5. Remove the overload protector(OLP) or PTC assembly. (See Figure 29)



Using Recipro Compressor model

Figure 29

3.3.3 COMPRESSOR

1. Discharge the refrigerant by using a refrigerant Recovery System.
2. After purging the unit completely, unbraid the suction and discharge tubes at the compressor connections.
3. Remove the nuts and washers which fasten the compressor. (See Figure 30)
4. Remove the compressor. (See Figure 30)

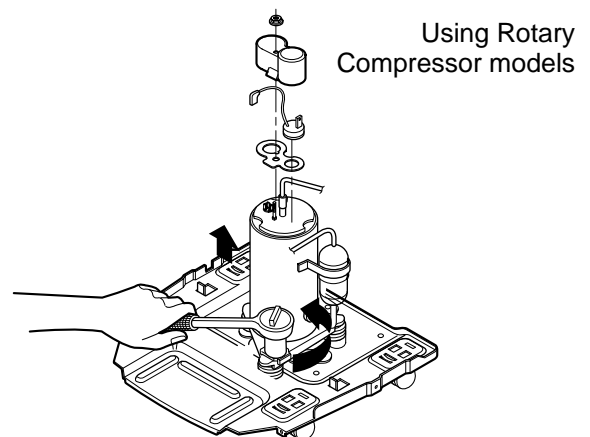

Figure 30

3.4 HOW TO REPLACE THE REFRIGERATION SYSTEM

1. When replacing a refrigeration component, be sure to discharge the refrigerant system by using a refrigerant recovery system.
2. After discharging the unit completely, remove the desired component, and unbraid the pinch-off tubes.
3. Solder service valves into the pinch-off tube ports, leaving the valves open.
4. Solder the pinch-off tubes with service valves.
5. After doing the above procedures, the valve must be closed and left in place on the system for any subsequent procedures.
6. Evacuate as follows.
 - 1) Connect the vacuum pump, as illustrated in Figure 31A.
 - 2) Start the vacuum pump, slowly open manifold valves A and B two full turns counterclockwise and leave the valves open.
The vacuum pump is now pulling through valves A and B to valve C by means of the manifold and entire system.

CAUTION

If high vacuum equipment is used, just crack valves A and B for a few minutes, then open slowly with the two full turns counterclockwise. This will keep oil from foaming and being drawn into the vacuum pump.

- 3) Operate the vacuum pump for 20 to 30 minutes, until 600 microns of vacuum are obtained. Close valves A and B, and observe vacuum gauge for a few minutes. A rise in pressure would indicate a possible leak or moisture remaining in the system. With valves A and B closed, stop the vacuum pump.
- 4) Remove the hose from the vacuum pump and place it on the charging cylinder. See Figure 31B. Open valve C.
Discharge the line at the manifold connection.
- 5) The system is now ready for final charging.

7. Recharge as follows :

- 1) Refrigeration cycle systems are charged from the High-side. If the total charge cannot be put in the High-side, the balance will be put in the suction line through the access valve which you installed as the system was opened.
- 2) Connect the charging cylinder as shown in Figure 31B.
With valve C open, discharge the hose at the manifold connection.
- 3) Open valve A and allow the proper charge to enter the system. Valve B is still closed.
- 4) If more charge is required, the high-side will not take it. Close valve A.
- 5) With the unit running, open valve B and add the balance of the charge.
 - a. Do not add the liquid refrigerant to the Low-side.
 - b. Watch the Low-side gauge; allow pressure to rise to 30 lbs.
 - c. Turn off valve B and allow pressure to drop.
 - d. Repeat steps B and C until the balance of the charge is in the system.
- 6) When satisfied the unit is operating correctly, use the pinch-off tool with the unit still running and clamp on to the pinch-off tube. Using a tube cutter, cut the pinch-off tube about 2 inches from the pinch-off tool. Use sil-fos solder and solder pinch-off tube closed. Turn off the unit, allow it to set for a while, and then test the leakage of the pinch-off connection.

NOTE: REFRIGERANT R134a IS USED IN SOME MODELS. CHECK THE SPECIFICATION LABEL ON THE CABINET.

When discharging refrigerant R134a, purging instrument should be used only for R134a, without mixing that of refrigerant R22.

When checking the leakage of refrigerant R134a, leakage test tool should be used only for R134a.

The pump for discharging should be high efficiency. Final discharging value must be managed below 0.5 Torr.

Maximum water should be less than 150mg in the cycle-all tubes and H/E assembly-system.

If water quantity is over 150mg, it causes acid or corrosion in the cycle system and the capillary tube to be clogged by water and harmful materials.

Models charged with refrigerant R134a should be used dryer to prevent water from overflowing.

Equipment needed: Vacuum pump, charging cylinder, manifold gauge, brazing equipment, pinch-off tool capable of making a vapor-proof seal, leak detector, tubing cutter, hand tools to remove components, service valve.

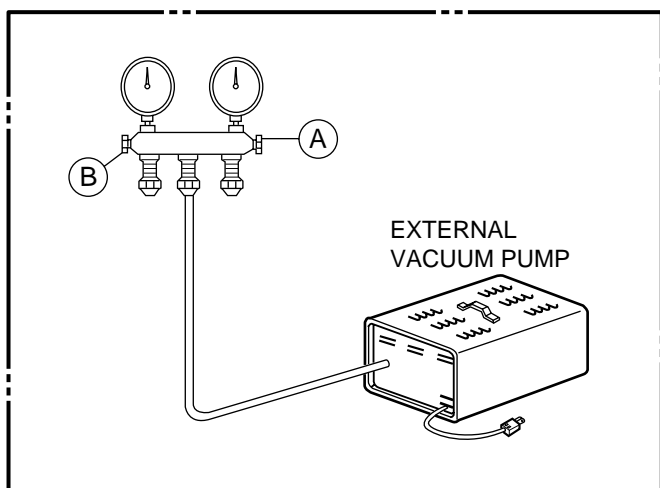
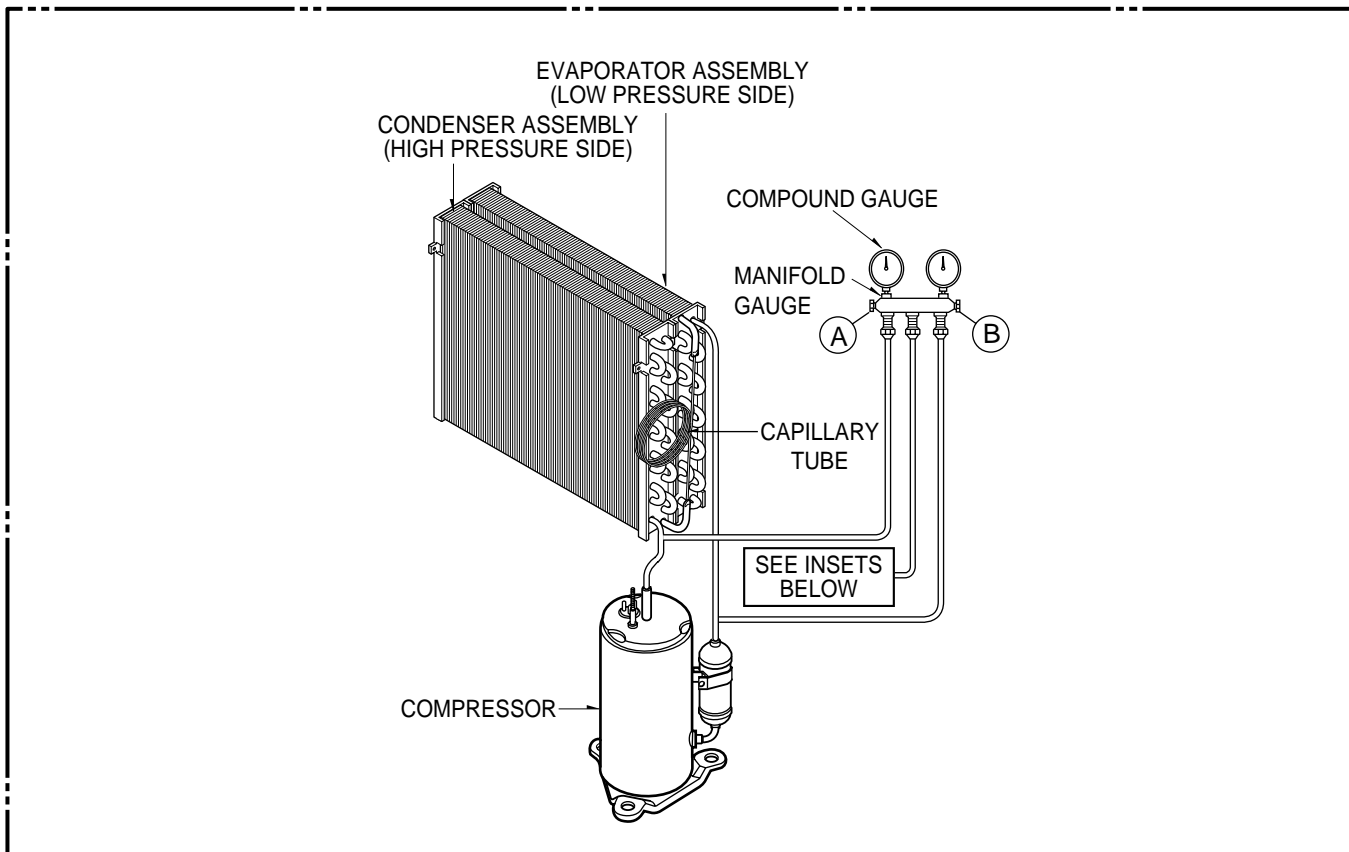

Figure 31A-Pulling Vacuum

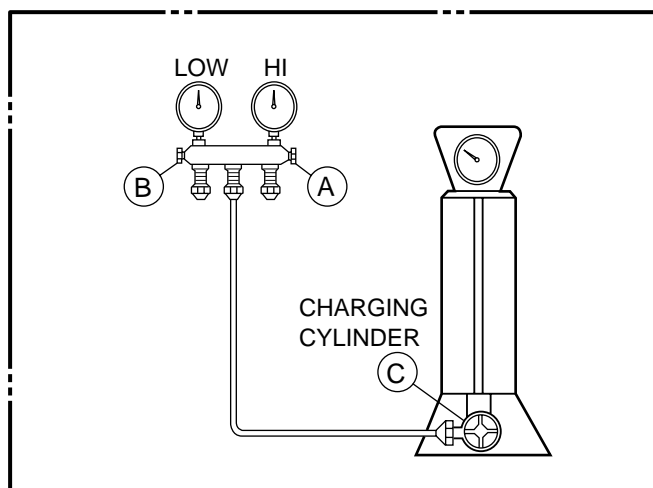

Figure 31B-Charging

4. TROUBLESHOOTING GUIDE

CONDITION	CAUSE	REMEDY
1. Dehumidifier does not start. (Both compressor and fan motor do not operate.)	No power	Check power supply at outlet. Correct if none.
	Poor plug contact at outlet.	Install plug properly or replace it.
	Bucket is full.	If Auto Shut Off lights, empty the bucket and replace properly.
	Humidity control is at Off position	Turn the humidity control switch toward Max.
	Wire disconnected or loose	Connect wire. Refer to wiring diagram for terminal identification. Repair or replace loose terminal.
	Capacitor. (Discharge capacitor before testing.)	Test capacitor. Replace if not within $\pm 10\%$ of manufacturer's rating. Replace if shorted, open, or damaged.
2. Motor runs but compressor does not run.	Voltage (115V \pm 10%)	It must be between 103.5V and 126.5V. If not within limits, call an electrician
	Wiring	Check the wire connections; If loose, repair or replace the terminal. If the wires are disconnected, refer to wiring diagram for identification, and replace the wires. Check the wire connections; If not according to the wiring diagram, correct the connections.
	Rotary switch	Check for continuity, refer to the wiring diagram for terminal identification. Replace the switch if the circuit is open.
	Defrost control	The Defrost Control senses frost build-up on the evaporator coil and automatically shuts off the compressor. The fan continues to run, drawing air across the coil, and melting the frost. When the coil is defrosted, the compressor automatically restarts, and dehumidifying resumes.
	Capacitor (Discharge capacitor before servicing.)	Check the capacitor. Replace if not within $\pm 10\%$ of manufacturer's rating. Replace if shorted, open, or damaged.
	Compressor	Check the compressor for open circuit or ground. If open or grounded, replace the compressor.
	Overload protector (OLP)	Check the compressor OLP if externally mounted. Replace if open. (If the compressor temperature is high, remove OLP, cool, and retest.)
3. Does not defrost control.	Defrost control is defective.	Check defrost control, replace it.
4. Insufficient dehumidification	Low relative humidity	Turn dehumidifier off.
	Poor air circulation	Move dehumidifier to obtain free and unobstructed air circulation.
	H/E clogged with dust and dirt	Clean evaporator and/or condenser assembly
	Air filter is dirty.	Clean it.
	Motor is not operating.	Check Motor, repair or replace it.

CONDITION	CAUSE	REMEDY
5. Noisy operating	Fan	If cracked, out of balance, or partially missing, replace it
	Loose foreign material inside the housing.	Remove it.
	Tube hits frame.	Adjust tubing routine carefully.
	Fan blade hits frame	Check Motor Mount. If loose, tighten it.
	Internal compressor noise.	Replace compressor.
	Loose set screws	Tighten them.
	Worn bearings of Motor Assembly	If knocking sounds continue when running or loose, replace the motor. If the motor hums or noise appears to be internal while running, replace motor assembly.
6. Water drips	The bucket is not installed properly.	The bucket should be properly positioned on the hangers of the drain pan.
	Connection may be loose.	Check connection and repair.
	Leak in bucket	Replace bucket.
	Water drips when bucket removed for emptying.	Before removing bucket, the unit should be turned off.
	Bucket overflows.	Check micro switch and float.
7. Compressor cycles on overload protector. (OLP)	High or low line voltage. (115V ± 10%)	Check line voltage. It must be between 103.5V and 126.5V volts. If intermittent, provide new supply.
	Poor air circulation.	Move dehumidifier for free and unobstructed air flow.
	Heat Exchange clogged with dust or dirt.	Clean dust or dirt on the Heat Exchange.
	Motor	If not running, determine the cause. Replace if required.
	Bad PTC assembly (if assembled)	Check PTC, Repair.
	Short circuit or ground in electrical circuit	Check electrical circuit. Repair.
	Unit pressures not equalized	Allow 2 or 3 minutes for pressure to equalize before starting compressor.
	Capacitor	Test the capacitor.
	Wiring	Check the terminals. If loose, repair or replace.
	Refrigeration system	Check the system for a restriction.
	Stuck compressor	Check compressor, replace compressor
	Overload protector (OLP)	Check OLP, if externally mounted. Replace if open. (If the compressor temperature is high, remove the OLP, cool, and retest.)

5. EXPLODED VIEWS

• MODEL: DH304/DH300M

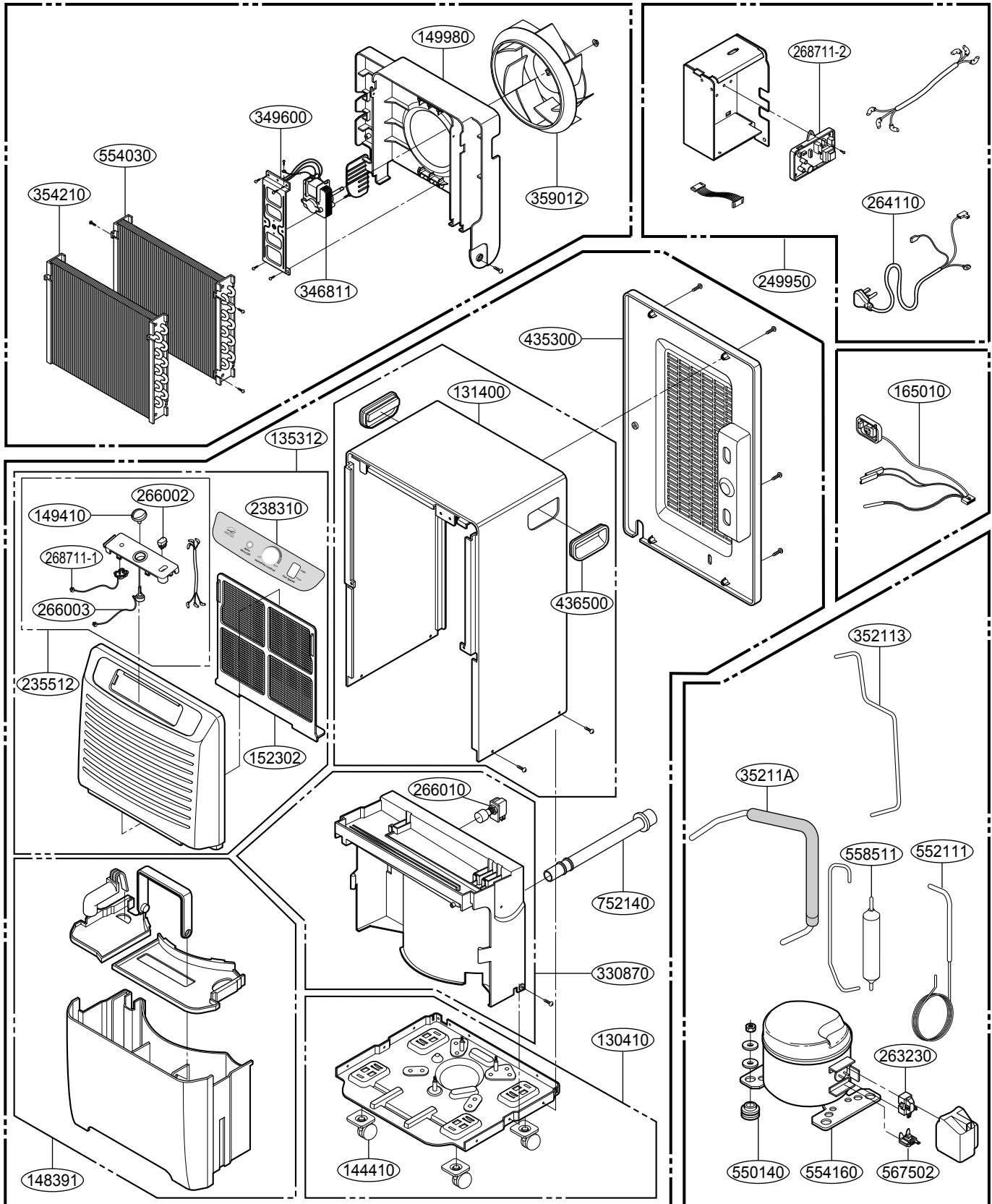

• MODEL: DH300E

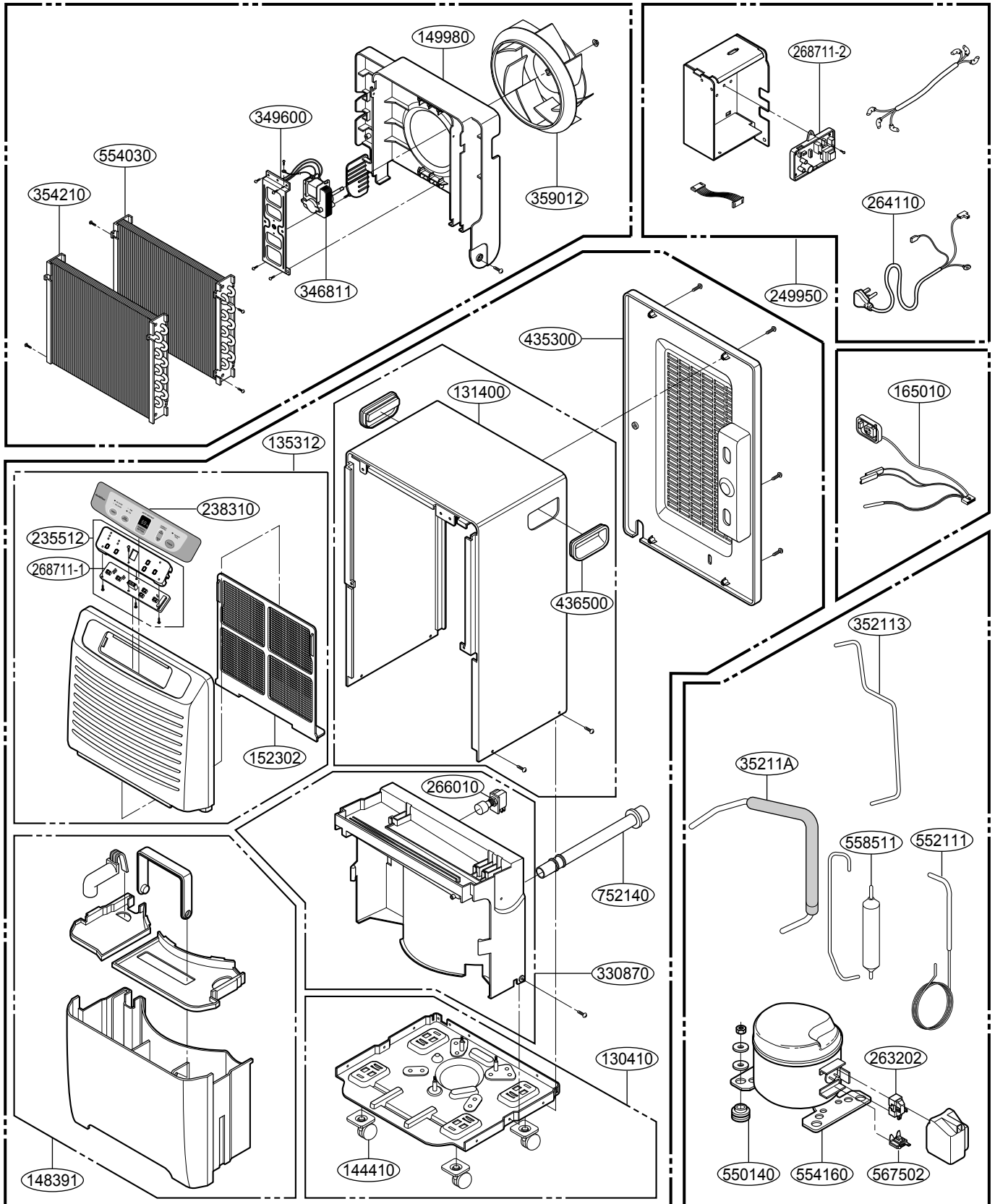

• MODEL: DH400M/LD40

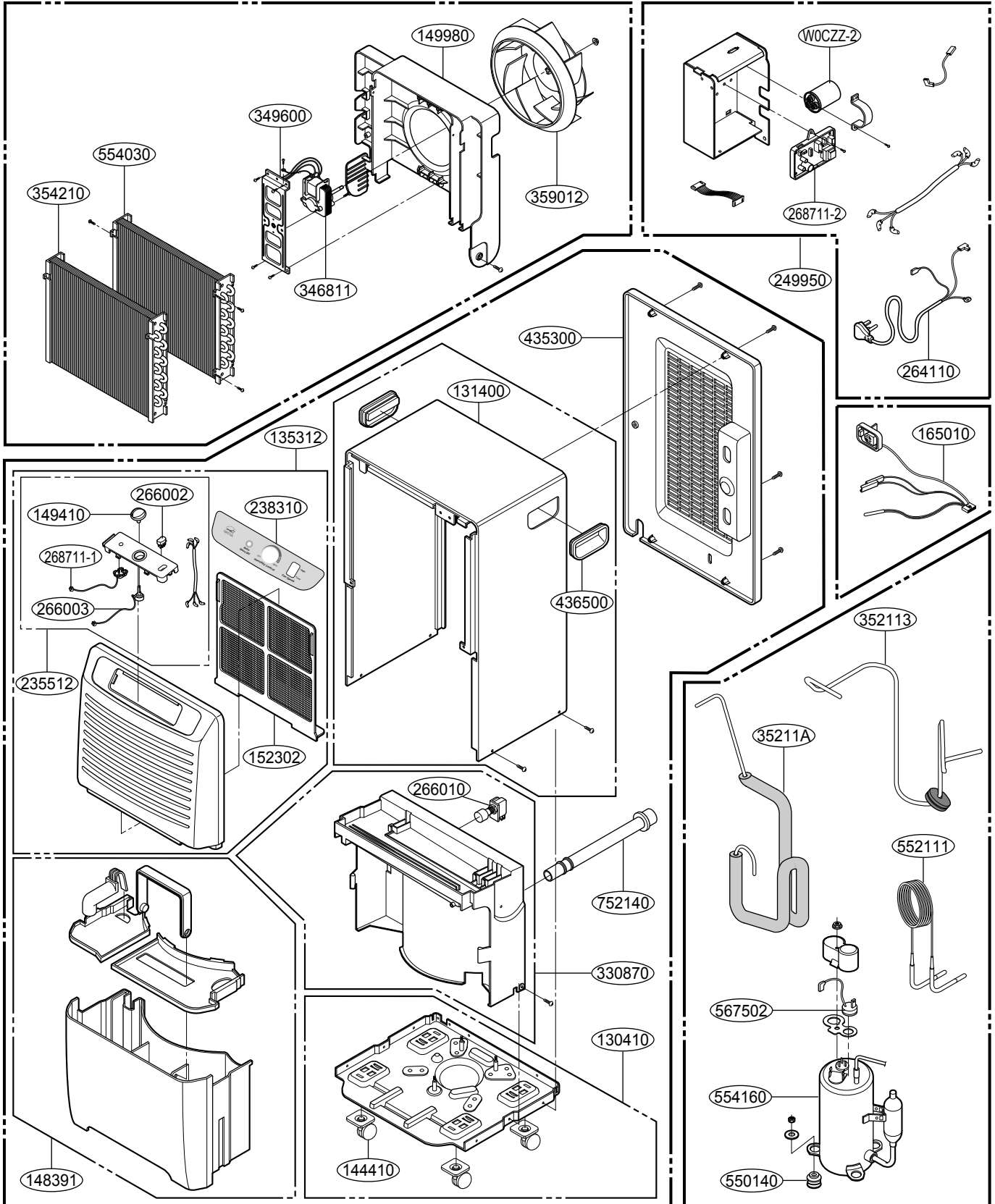

• MODEL: GD40E/DH404E/DH400E/LD40E

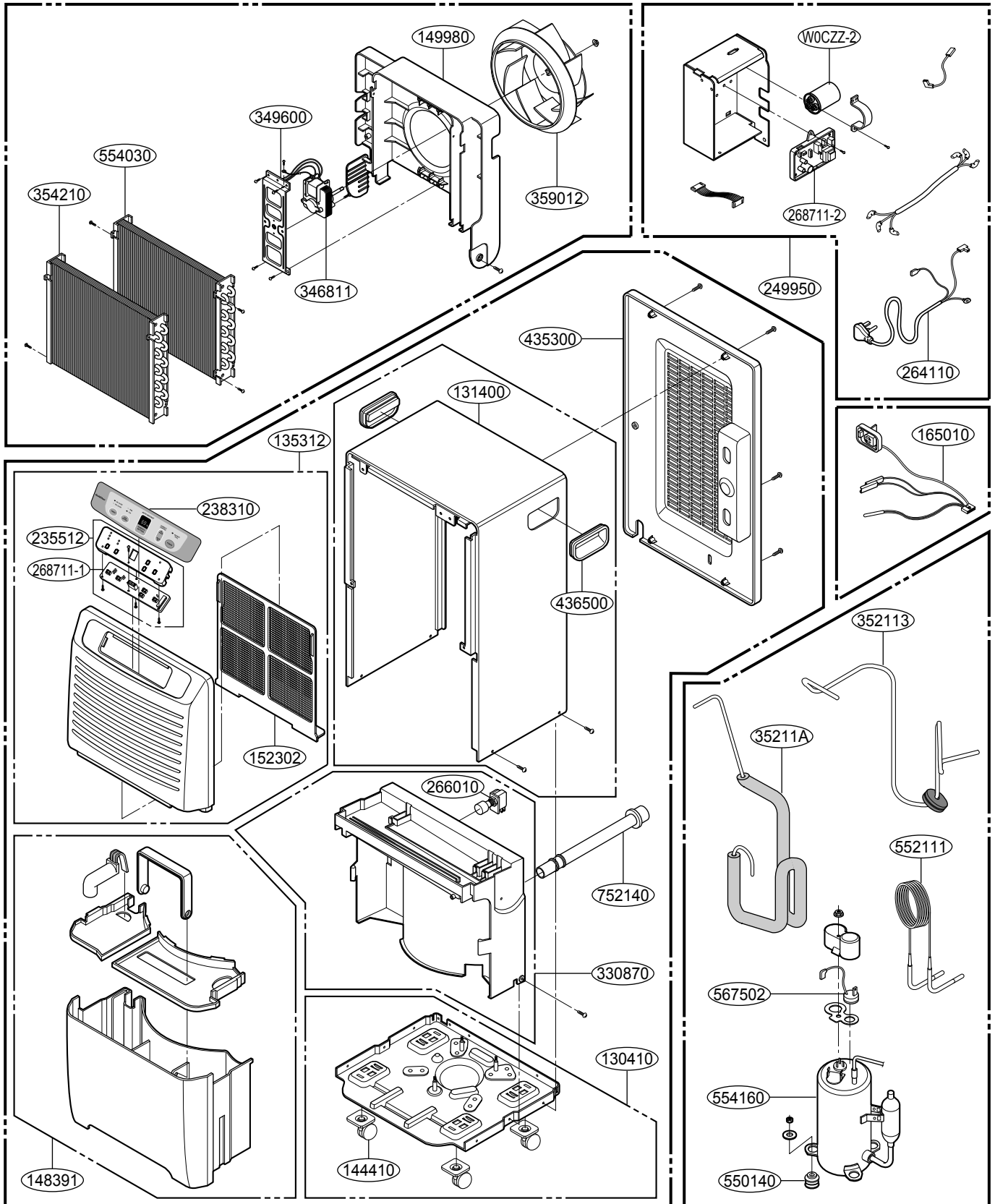

• MODEL: DH504EL/LD50EL

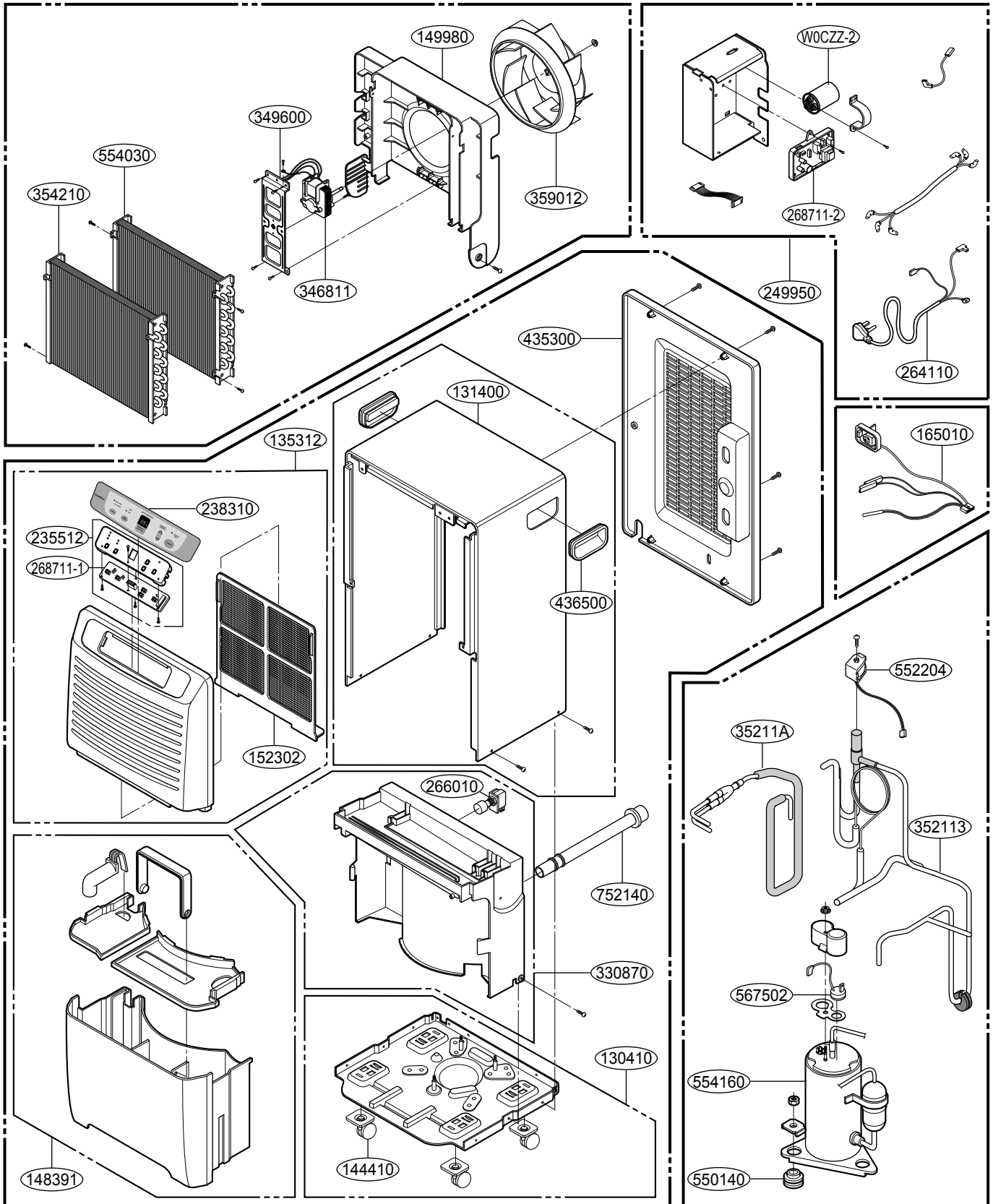

• MODEL: LD65EL

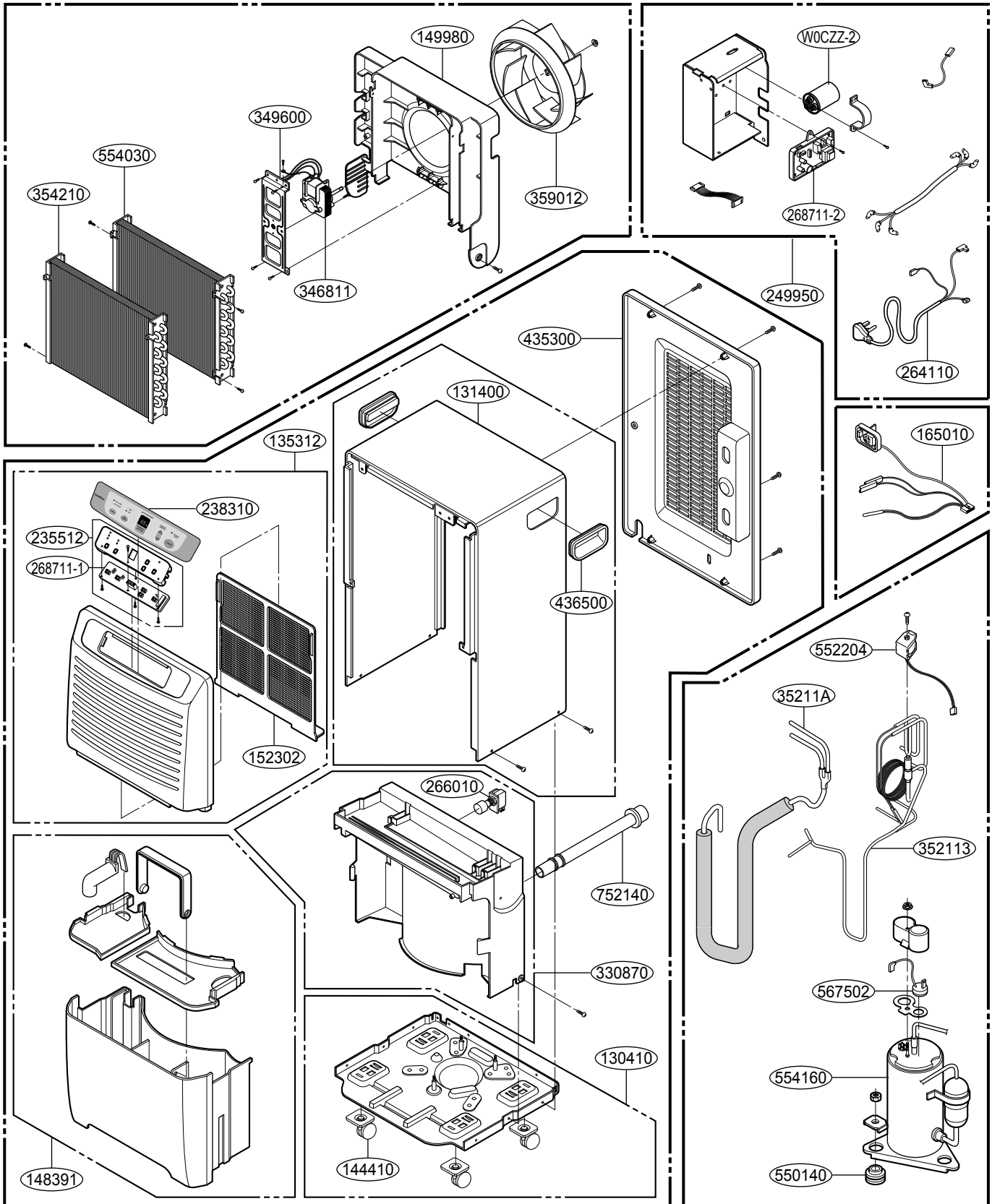

6. REPLACEMENT PARTS LIST

• MODEL: DH304/DH300M

LOCATION NO.	DESCRIPTION	PART NO.	REMARK
		DH304/DH300M	
130410	BASE ASSEMBLY	3041A10042C	
131400	CABINET	3090A10042A	
135312	FRONT GRILLE,ASSEMBLY	3531A10285C	
330870	DRAIN PAN ASSEMBLY	3087A10019B	
148391	TANK ASSEMBLY,BUCKET	4839A10002A	
149410	KNOB ASSEMBLY	4941A30019B	
152302	FILTER(MECH),AIR	5230A20040A	
165010	SENSOR ASEMBLY	6877A30013L	
249950	CONTROL BOX,ASSEMBLY	4995A20359J	
264110	POWER CORD,ASSEMBLY	6411A20001Z	
266002	SWITCH,ROCKER	6600FX5001G	
266003	SWITCH ASSEMBLY,ROTARY	6601A30001B	
266010	SWITCH ASSEMBLY,MICRO	6600A30003C	
268711-1	PWB(PCB)ASSEMBLY,DISPLAY	6871A20289B	
268711-2	PWB(PCB)ASSEMBLY,MAIN	6871A10142A	
346811	MOTOR ASSEMBLY	4681A20040J	
35211A	TUBE ASSEMBLY,SUCTION	5211A10464A	
352113	TUBE ASSEMBLY,DISCHARGE	5211A11019A	
552111	TUBE ASSEMBLY,CAPILLARY	5211A30720A	
354210	EVAPORATOR,ASSEMBLY	5421A10009P	
554030	CONDENSOR ASSEMBLY	5403A10008N	
558511	DRIER ASSEMBLY	5851A30001A	
554160	COMPRESSOR ,SET	2521C-A8626	
359012	FAN,TURBO	5900A20007A	
567502	OLP	6750C-0009E	
349600	MOUNT,MOTOR	4960A20009B	
263230	PTC ASSEMBLY	6748C-0003D	
436500	HANDLE	3650A20004A	
144410	CASTER ASSEMBLY,ROLLER	4441A30001B	
238310	ESCUTCHEON	3831A20079M	
235512	COVER ASSEMBLY,DISPLAY	3551A20122A	
752140	HOSE,CONNECTOR	5214A20027A	
550140	ISOLATOR,COMP	5040AR4195A	
149980	SHROUD	4998A10034A	
435300	REAR GRILLE	3530A10193A	

• **MODEL: DH300E**

LOCATION NO.	DESCRIPTION	PART NO.	REMARK
		DH300E	
130410	BASE ASSEMBLY	3041A10042C	
131400	CABINET	3090A10042A	
135312	FRONT GRILLE,ASSEMBLY	3531A10254F	
330870	DRAIN PAN ASSEMBLY	3087A10019B	
148391	TANK ASSEMBLY,BUCKET	4839A10002A	
152302	FILTER(MECH),AIR	5230A20040A	
165010	SENSOR ASEMBLY	6877A30013L	
249950	CONTROL BOX,ASSEMBLY	4995A20359G	
264110	POWER CORD,ASSEMBLY	6411A20001Z	
266010	SWITCH ASSEMBLY,MICRO	6600A30003C	
268711-1	PWB(PCB)ASSEMBLY,DISPLAY	6871A20482A	
268711-2	PWB(PCB)ASSEMBLY,MAIN	6871A10141A	
346811	MOTOR ASSEMBLY	4681A20040J	
35211A	TUBE ASSEMBLY,SUCTION	5211A10464A	
352113	TUBE ASSEMBLY,DISCHARGE	5211A11019A	
552111	TUBE ASSEMBLY,CAPILLARY	5211A30720A	
354210	EVAPORATOR,ASSEMBLY	5421A10009P	
554030	CONDENSOR ASSEMBLY	5403A10008N	
558511	DRIER ASSEMBLY	5851A30001A	
554160	COMPRESSOR ,SET	2521C-A8626	
359012	FAN,TURBO	5900A20007A	
567502	OLP	6750C-0009E	
349600	MOUNT,MOTOR	4960A20009B	
263230	PTC ASSEMBLY	6748C-0003D	
436500	HANDLE	3650A20004A	
144410	CASTER ASSEMBLY,ROLLER	4441A30001B	
238310	ESCUTCHEON	3831A20079L	
235512	COVER ASSEMBLY,DISPLAY	3551A20109B	
752140	HOSE,CONNECTOR	5214A20027A	
550140	ISOLATOR,COMP	5040AR4195A	
149980	SHROUD	4998A10034A	
435300	REAR GRILLE	3530A10193A	

• **MODEL: DH400M/LD40**

LOCATION NO.	DESCRIPTION	PART NO.	REMARK
		DH400M/LD40	
130410	BASE ASSEMBLY	3041A10042B	
131400	CABINET	3090A10042A	
135312	FRONT GRILLE,ASSEMBLY	3531A10285B / 3531A10254A	"B:LG/A:Goldstar"
330870	DRAIN PAN ASSEMBLY	3087A10019A	
148391	TANK ASSEMBLY,BUCKET	4839A10002A	
149410	KNOB ASSEMBLY	4941A30019B	
152302	FILTER(MECH),AIR	5230A20040A	
165010	SENSOR ASEMBLY	6877A30013M	
W0CZZ-2	CAPACITOR	0CZZA20005N	
249950	CONTROL BOX,ASSEMBLY	4995A20359H	
264110	POWER CORD,ASSEMBLY	6411A20001Z	
266002	SWITCH,ROCKER	6600FX5001G	
266003	SWITCH ASSEMBLY,ROTARY	6601A30001B	
266010	SWITCH ASSEMBLY,MICRO	6600A30003C	
268711-1	PWB(PCB)ASSEMBLY,DISPLAY	6871A20289B	
268711-2	PWB(PCB)ASSEMBLY,MAIN	6871A10142A	
346811	MOTOR ASSEMBLY	4681A20040J	
35211A	TUBE ASSEMBLY,SUCTION	5211A10460A	
352113	TUBE ASSEMBLY,DISCHARGE	5211A10463A	
552111	TUBE ASSEMBLY,CAPILLARY	5211A31003B	
354210	EVAPORATOR,ASSEMBLY	5421A10009N	
554030	CONDENSOR ASSEMBLY	5403A10008M	
554160	COMPRESSOR ,SET	2520UCAS003	
359012	FAN,TURBO	5900A20007A	
567502	OLP	6750U-L103A	
349600	MOUNT,MOTOR	4960A20009B	
436500	HANDLE	3650A20004A	
144410	CASTER ASSEMBLY,ROLLER	4441A30001B	
238310	ESCUTCHEON	3831A20079E/K	"E:Goldstar/K:LG"
235512	COVER ASSEMBLY,DISPLAY	3551A20122A	
752140	HOSE,CONNECTOR	5214A20027A	
550140	ISOLATOR,COMP	4830A30005A	
149980	SHROUD	4998A10034A	
435300	REAR GRILLE	3530A10193A	

• **MODEL: GD40E/DH404E/DH400E/LD40E**

LOCATION NO.	DESCRIPTION	PART NO.	REMARK
		GD40E/DH404E/DH400E/LD40E	
130410	BASE ASSEMBLY	3041A10042B	
131400	CABINET	3090A10042A	
135312	FRONT GRILLE,ASSEMBLY	3531A10254A/E	"A:Goldstar/E:LG"
330870	DRAIN PAN ASSEMBLY	3087A10019A	
148391	TANK ASSEMBLY,BUCKET	4839A10002A	
152302	FILTER(MECH),AIR	5230A20040A	
165010	SENSOR ASEMBLY	6877A30013M	
W0CZZ-2	CAPACITOR	0CZZA20005N	
249950	CONTROL BOX,ASSEMBLY	4995A20359F	
264110	POWER CORD,ASSEMBLY	6411A20001Z	
266010	SWITCH ASSEMBLY,MICRO	6600A30003C	
268711-1	PWB(PCB)ASSEMBLY,DISPLAY	6871A20482A	
268711-2	PWB(PCB)ASSEMBLY,MAIN	6871A10141A	
346811	MOTOR ASSEMBLY	4681A20040J	
35211A	TUBE ASSEMBLY,SUCTION	5211A10460A	
352113	TUBE ASSEMBLY,DISCHARGE	5211A10463A	
552111	TUBE ASSEMBLY,CAPILLARY	5211A31003B	
354210	EVAPORATOR,ASSEMBLY	5421A10009N	
554030	CONDENSOR ASSEMBLY	5403A10008M	
554160	COMPRESSOR ,SET	2520UCAS003	
359012	FAN,TURBO	5900A20007A	
567502	OLP	6750U-L103A	
349600	MOUNT,MOTOR	4960A20009B	
436500	HANDLE	3650A20004A	
144410	CASTER ASSEMBLY,ROLLER	4441A30001B	
238310	ESCUTCHEON	3831A20079A/J	"A:Goldstar/J:LG"
235512	COVER ASSEMBLY,DISPLAY	3551A20109B	
752140	HOSE,CONNECTOR	5214A20027A	
550140	ISOLATOR,COMP	4830A30005A	
149980	SHROUD	4998A10034Y	
435300	REAR GRILLE	3530A10193A	

• **MODEL: DH504EL/LD50EL**

LOCATION NO.	DESCRIPTION	PART NO.	REMARK
		DH504EL/LD50EL	
130410	BASE ASSEMBLY	3041A10042A	
131400	CABINET	3090A10042A	
135312	FRONT GRILLE,ASSEMBLY	3531A10254A/E	"A:Goldstar/E:LG"
330870	DRAIN PAN ASSEMBLY	3087A10019A	
148391	TANK ASSEMBLY,BUCKET	4839A10002A	
152302	FILTER(MECH),AIR	5230A20040A	
165010	SENSOR ASEMBLY	6877A30013L	
W0CZZ-2	CAPACITOR	0CZZA20001R	
249950	CONTROL BOX,ASSEMBLY	4995A20359E	
264110	POWER CORD,ASSEMBLY	6411A20001Z	
266010	SWITCH ASSEMBLY,MICRO	6600A30003C	
268711-1	PWB(PCB)ASSEMBLY,DISPLAY	6871A20482A	
268711-2	PWB(PCB)ASSEMBLY,MAIN	6871A10141C	
346811	MOTOR ASSEMBLY	4681A20040J	
35211A	TUBE ASSEMBLY,SUCTION	5211A10428A	
352113	TUBE ASSEMBLY,DISCHARGE	5211A11016A	
552204	COIL ASSEMBLY,SOLENOID	6421A20003K	
354210	EVAPORATOR,ASSEMBLY	5421A10009J	
554030	CONDENSOR ASSEMBLY	5403A10008A	
554160	COMPRESSOR ,SET	2520UCAAA014	
359012	FAN,TURBO	5900A20007A	
567502	OLP	6750U-L058A	
349600	MOUNT,MOTOR	4960A20009B	
436500	HANDLE	3650A20004A	
144410	CASTER ASSEMBLY,ROLLER	4441A30001B	
238310	ESCUTCHEON	3831A20079A/J	"A:Goldstar/J:LG"
235512	COVER ASSEMBLY,DISPLAY	3551A20109B	
752140	HOSE,CONNECTOR	5214A20027A	
550140	ISOLATOR,COMP	4830A30005A	
149980	SHROUD	4998A10034A	
435300	REAR GRILLE	3530A10193A	

• **MODEL: LD65EL**

LOCATION NO.	DESCRIPTION	PART NO.	REMARK
		LD65EL	
130410	BASE ASSEMBLY	3041A10042A	
131400	CABINET	3090A10042A	
135312	FRONT GRILLE,ASSEMBLY	3531A10254E	
330870	DRAIN PAN ASSEMBLY	3087A10019A	
148391	TANK ASSEMBLY,BUCKET	4839A10002A	
152302	FILTER(MECH),AIR	5230A20040A	
165010	SENSOR ASEMBLY	6877A30013L	
W0CZZ-2	CAPACITOR	0CZZA20005J	
249950	CONTROL BOX,ASSEMBLY	4995A20359L	
264110	POWER CORD,ASSEMBLY	6411A20001Z	
266010	SWITCH ASSEMBLY,MICRO	6600A30003C	
268711-1	PWB(PCB)ASSEMBLY,DISPLAY	6871A20482A	
268711-2	PWB(PCB)ASSEMBLY,MAIN	6871A10141C	
346811	MOTOR ASSEMBLY	4681A20040K	
35211A	TUBE ASSEMBLY,SUCTION	5211A10454A	
352113	TUBE ASSEMBLY,DISCHARGE	5211A10455A	
552204	COIL ASSEMBLY,SOLENOID	6421A20003K	
354210	EVAPORATOR,ASSEMBLY	5421A10009H	
554030	CONDENSOR ASSEMBLY	5403A10008L	
554160	COMPRESSOR ,SET	2520UCBA007	
359012	FAN,TURBO	5900A20007A	
567502	OLP	6750U-L048A	
349600	MOUNT,MOTOR	4960A20009B	
436500	HANDLE	3650A20004A	
144410	CASTER ASSEMBLY,ROLLER	4441A30001B	
238310	ESCUTCHEON	3831A20079J	
235512	COVER ASSEMBLY,DISPLAY	3551A20109B	
752140	HOSE,CONNECTOR	5214A20027A	
550140	ISOLATOR,COMP	4830A30005A	
149980	SHROUD	4998A10034A	
435300	REAR GRILLE	3530A10193A	



P/No : 3828A31001A

January, 2004
Printed in China