

This Owner's Manual is provided and hosted by [Appliance Factory Parts](#).



LG LW-B0810CL Owner's Manual

[Shop genuine replacement parts for LG LW-B0810CL](#)



[Find Your LG Air Conditioner Parts - Select From 2328 Models](#)

----- Manual continues below -----

2. DISASSEMBLY INSTRUCTIONS

- Before disassembling, turn the POWER SWITCH to OFF and disconnect the power cord.

2.1 MECHANICAL PARTS

2.1.1 FRONT GRILLE

1. Open the INLET GRILLE upward and remove the air filter.
2. Remove the screw which fastens the FRONT GRILLE.
3. Pull the FRONT GRILLE from the right side.
4. Remove the FRONT GRILLE.
5. Re-install the components by referring to the above removal procedure. (See figure 1)

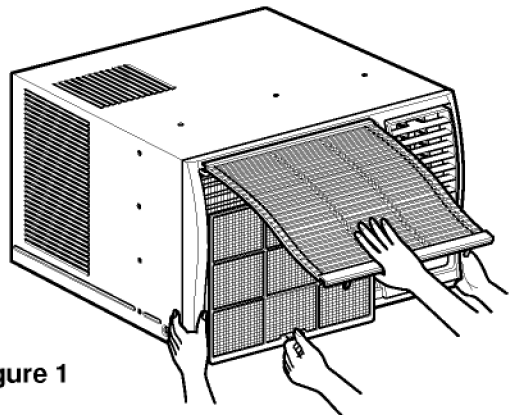

Figure 1

2.1.2 CABINET

1. After disassembling the FRONT GRILLE, remove the two screws which fasten the CABINET at both sides.
2. Remove the two screws which fasten the CABINET at back.
3. Pull the BASE PAN forward. (See figure 2)

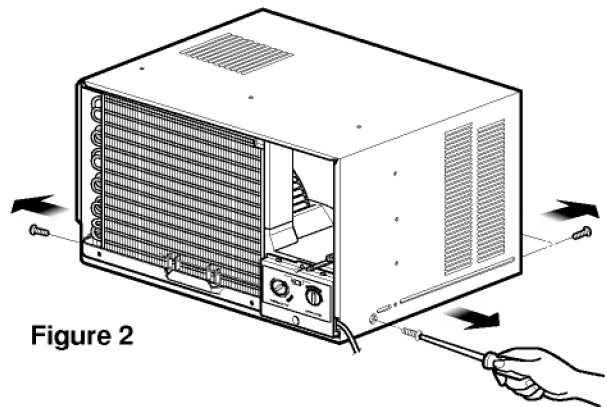

Figure 2

2.1.3 CONTROL BOX

1. Remove the front grille. (Refer to section 2.1.1)
2. Remove the 3 screws which fasten the CONTROL BOX.
3. Pull the CONTROL BOX forward about 10-15cm (1/2").
4. Discharge the CAPACITOR by placing a 20,000 ohm resistor across the capacitor terminals.
5. Remove two wire housings in the control box.
6. Pull the control box forward completely.
7. Re-install the components by referring to the above removal procedure. (See figure 3)
(Refer to the CIRCUIT DIAGRAM found on pages 26~31 in this manual and on the control box.)

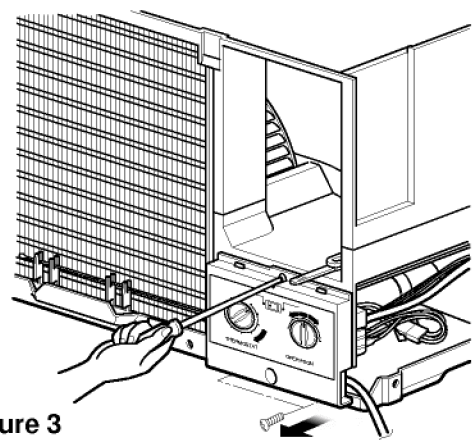

Figure 3

2.2 AIR HANDLING PARTS

2.2.1 AIR GUIDE

1. Remove the front grille. (Refer to section 2.1.1)
2. Remove the cabinet. (Refer to section 2.1.2)
3. Pull the cover E.P.S upward.
4. Remove 3 screws which fasten the UPPER AIR GUIDE.
5. Push the two hooks which fasten the UPPER AIR GUIDE and remove the UPPER AIR GUIDE.
6. Re-install the components by referring to the above removal procedure. (See figure 4 and 5)

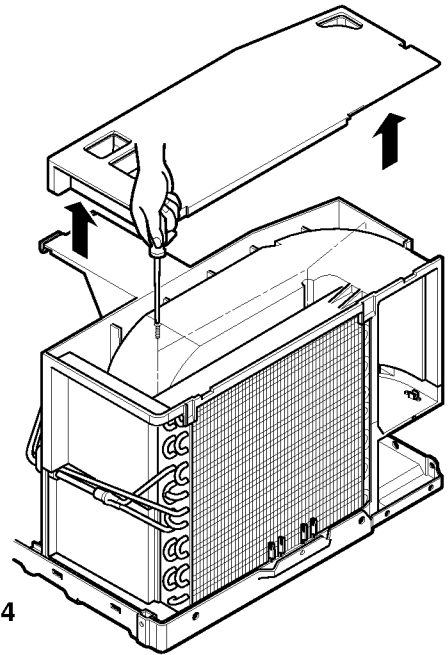

Figure 4

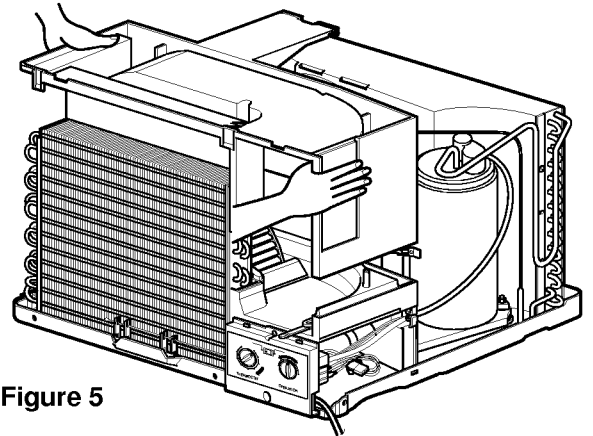

Figure 5

2.2.2 BLOWER

1. Remove the upper air guide. (Refer to section 2.2.1)
2. Move the evaporator sideways carefully.
3. Remove the clamp which secures the blower with a hand plier. (See figure 6)
4. Remove 2 screws which fasten the MOTOR MOUNT.
5. Pull the BLOWER forward by dragging the motor mount upward carefully.
6. Remove the BLOWER.
7. Re-install the components by referring to the above removal procedure. (See figure 7)

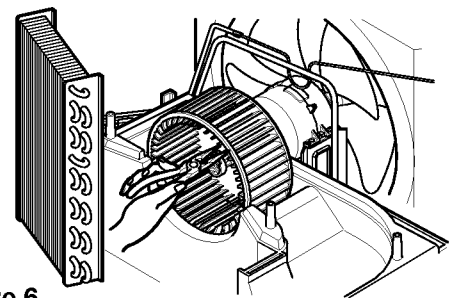

Figure 6

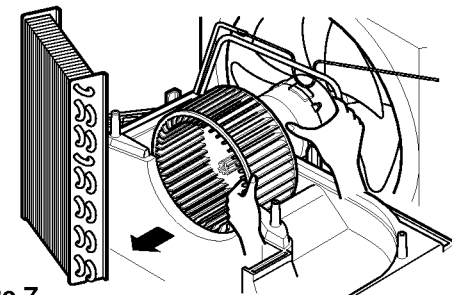

Figure 7

2.2.3 FAN, SHROUD

1. Remove the cabinet. (Refer to section 2.1.2)
2. Remove the 4 screws which fasten the condenser.
3. Move the condenser sideward carefully.
4. Remove the clamp which secures the FAN with a hand plier.
5. Remove the FAN.
6. Remove the SHROUD.
7. Re-install by referring to the above removal procedure.
(See figure 8 and 9)

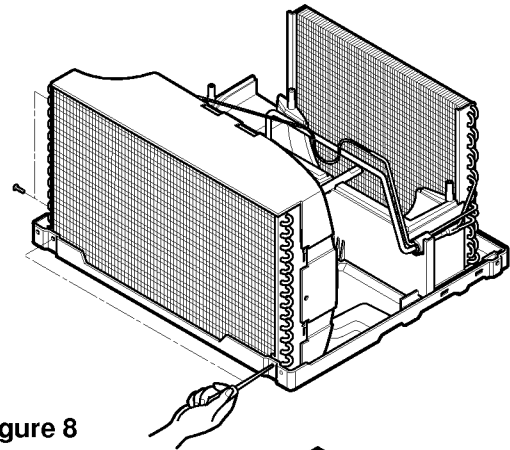

Figure 8

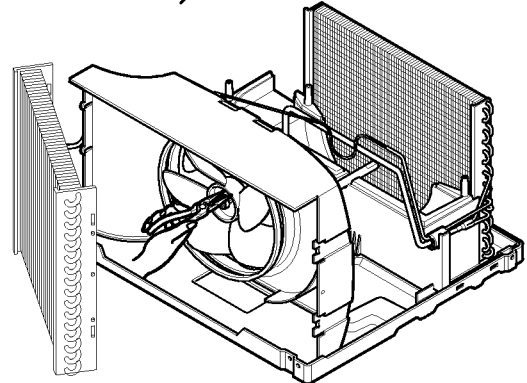

Figure 9

2.3 ELECTRICAL PARTS

2.3.1 OVERLOAD PROTECTOR

1. Remove the cabinet. (Refer to section 2.1.2)
2. Remove the nut which fastens the TERMINAL COVER.
3. Remove the terminal cover.
4. Remove all the leads from the OVERLOAD PROTECTOR.
5. Remove the overload protector.
6. Re-install the components by referring to the above removal procedure.
(See figures 10 and 11)

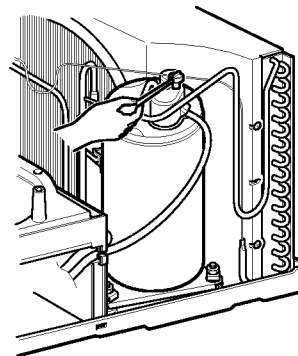

Figure 10

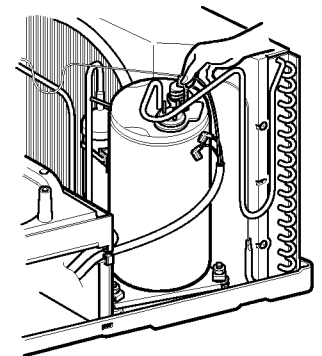

Figure 11

2.3.2 COMPRESSOR

1. Remove the cabinet. (Refer to section 2.1.2)
2. Discharge the refrigerant system using a Freon™ Recovery System.
If there is no valve to attach the recovery system, install one (such as a WATCO A-1) before venting the Freon™. Leave the valve in place after servicing the system.
3. Remove the overload protector. (Refer to section 2.3.1)
4. After purging the unit completely, detach the suction tube and the discharge tubes at the compressor connections.
5. Remove the 3 nuts and the 3 bracket washers which fasten the compressor.
6. Remove the compressor.
7. Re-install the components by referring to the above removal procedure. (See figure 12)

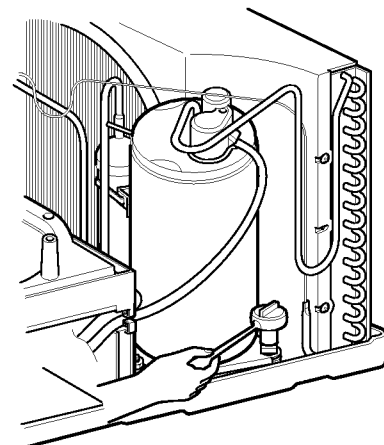

Figure 12

2.3.3 CAPACITOR

1. Remove the control box. (Refer to section 2.1.3)
2. Remove the screw and the clamp which fasten the CAPACITOR.
3. Disconnect all the leads of the capacitor terminals.
4. Re-install the components by referring to the above removal procedure. (See figure 13)

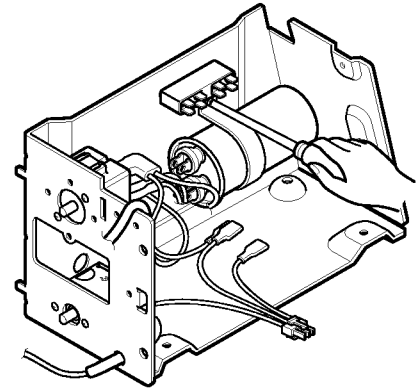

Figure 13

2.3.4 POWER CORD

1. Remove the control box. (Refer to section 2.1.3)
2. Disconnect the grounding screw from the control box. (See figure 14)
3. Disconnect the 2 receptacles.
4. Remove the screw which fastens the CLIP CORD.
5. Pull the power cord. (See figure 15)
6. Re-install the components by referring to the above removal procedure.
(Use only one ground-marked hole \oplus for ground connection.)

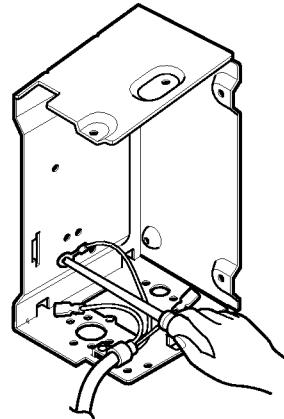

Figure 14

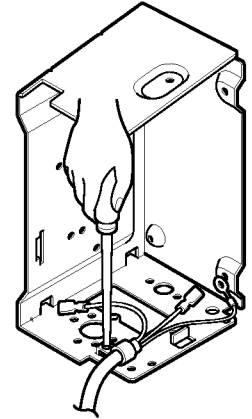

Figure 15

2.3.5 THERMOSTAT

1. Remove the control box. (Refer to section 2.1.3)
2. Remove the screw which fastens the display panel.
3. Remove the two knobs.
4. Remove the display panel.
5. Remove the 2 screws which fasten the thermostat.
6. Disconnect all the leads of thermostat terminals.
7. Remove the THERMOSTAT.
8. Re-install the components by referring to the above removal procedure. (See figure 16)

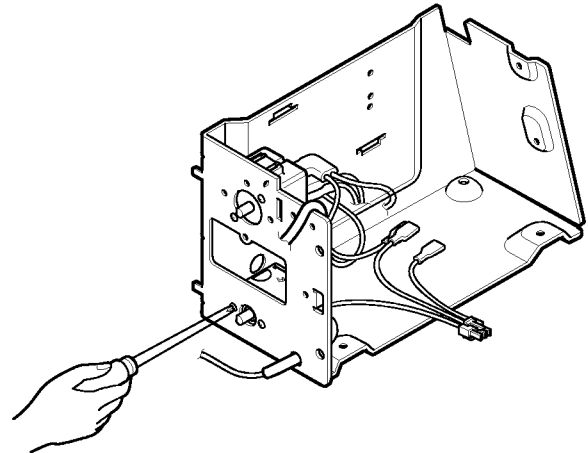

Figure 16

2.3.6 ROTARY SWITCH

1. Remove the control box. (Refer to section 2.1.3)
2. Remove the screw which fastens the display panel.
3. Remove the two knobs.
4. Remove the display panel.
5. Remove the 2 screws which fasten the rotary switch.
6. Disconnect all the leads of the rotary switch terminals.
7. Remove the rotary switch.
8. Re-install the components by referring to the above removal procedure. (See figure 17)

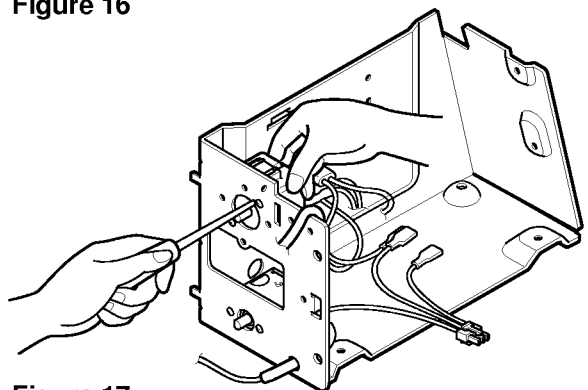

Figure 17

2.3.7 MOTOR

1. Remove the cabinet. (Refer to section 2.1.2)
2. Remove the upper air guide. (Refer to section 2.2.1)
3. Remove the blower. (Refer to section 2.2.2)
4. Remove the fan. (Refer to section 2.2.3)
5. Remove the shroud. (Refer to section 2.2.3)
6. Remove the control box. (Refer to section 2.1.3)
7. Remove the 2 screws which fasten the motor.
8. Remove the motor.
9. Re-install the components by referring to the above removal procedure. (See figure 18)

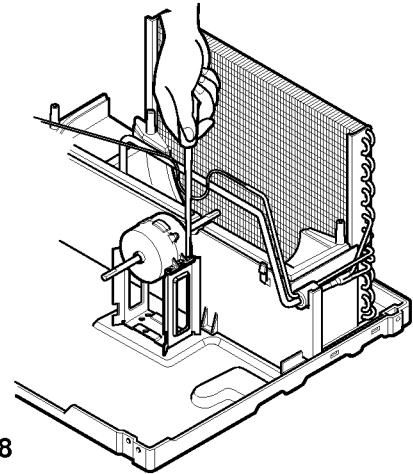

Figure 18

2.4 REFRIGERATING CYCLE

2.4.1 CONDENSER

1. Remove the cabinet. (Refer to section 2.1.2)
2. Discharge the refrigerant system using a Freon™ Recovery System.
If there is no valve to attach the recovery system, install one (such as a WATCO A-1) before venting the Freon™. Leave the valve in place after servicing the system.
3. Remove the 4 screws which fasten the condenser.
4. After discharging the refrigerant completely, detach the interconnecting tube at the condenser connections.
5. Remove the condenser.
6. Re-install the components by referring to notes. (See figure 19)

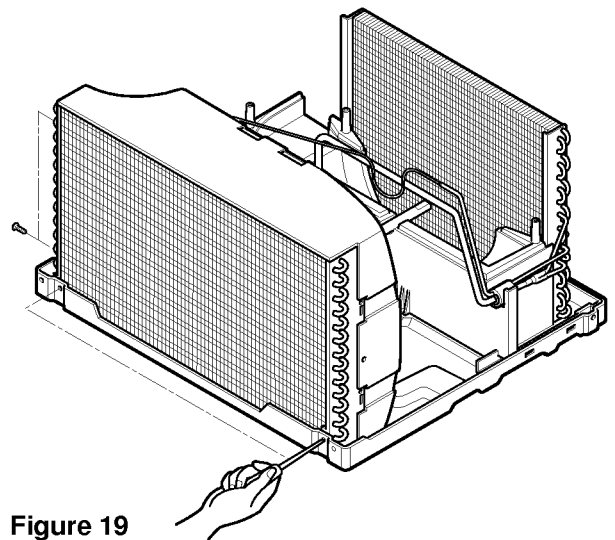

Figure 19

2.4.2 EVAPORATOR

1. Remove the cabinet. (Refer to section 2.1.2)
2. Discharge the refrigerant system using a Freon™ Recovery System.
If there is no valve to attach the recovery system, install one (such as a WATCO A-1) before venting the Freon™. Leave the valve in place after servicing the system.
3. Remove the cover E.P.S and the upper air guide. (Refer to section 2.2.1)
4. After discharging the refrigerant completely, detach the interconnecting tube at the evaporator connections.
5. Remove the evaporator.
6. Re-install the components by referring to notes. (See figure 20)

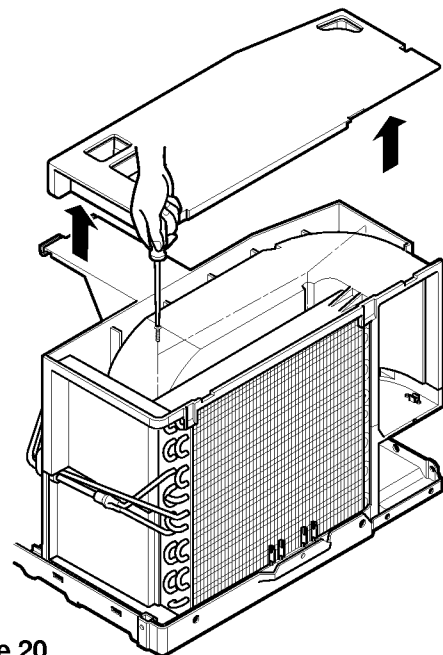

Figure 20

2.4.3 CAPILLARY TUBE

1. Remove the cabinet. (Refer to section 2.1.2)
2. Remove the upper air guide. (Refer to section 2.2.1)
3. Discharge the refrigerant system using a Freon™ Recovery System.

If there is no valve to attach the recovery system, install one (such as a WATCO A-1) before venting the Freon™. Leave the valve in place after servicing the system.

4. After discharging the refrigerant completely, detach the interconnecting tube at the CAPILLARY TUBE.
5. Remove the CAPILLARY TUBE.
6. Re-install the component by referring to notes.

NOTES

– Replacement of the refrigerating cycle.

1. When replacing the refrigerating cycle, discharge the refrigerant system using a Freon™ Recovery System.

If there is no valve to attach the recovery system, install one (such as a WATCO A-1) before venting the Freon™. Leave the valve in place after servicing the system.

2. After discharging the unit completely, remove the desired component, and detach the pinch-off tubes.
3. Solder service valves into the pinch-off tube ports, leaving the valves open.
4. Solder the pinch-off tubes with care.
5. Evacuate as follows:

- 1) Connect the vacuum pump, as illustrated Figure 21A.
- 2) Start the vacuum pump, slowly open manifold valves A and B with the two full turns counter-clockwise and leave the valves open.
The vacuum pump is now pulling through valves A and B up to valve C by means of the manifold and entire system.

CAUTION

If high vacuum equipment is used, just crack valves A and B for a few minutes, then open slowly with the two full turns counter-clockwise. This will keep oil from foaming and being drawn into the vacuum pump.

- 3) Operate the vacuum pump for 20 to 30 minutes, until 600 microns of vacuum is obtained. Close valves A and B and observe vacuum gauge for a few minutes. A rise in pressure would indicate a possible leak or moisture remaining in the system. With valves A and B closed, stop the vacuum pump.

- 4) Remove the hose from the vacuum pump and place it on the charging cylinder. See figures 21A and 21B. Open valve C.
Discharge the line at the manifold connection.
- 5) The system is now ready for final charging.

6. Recharge as follows :

- 1) Refrigerating cycle systems are charged from the High-side. If the total charge cannot be put in the High-side, the balance will be put in the suction line through the access valve which you installed as the system was opened.

- 2) Connect the charging cylinder as shown in figure 21B.

With valve C open, discharge the hose at the manifold connection.

- 3) Open valve A and allow proper charge to enter the system. Valve B is still closed.

- 4) If more charge is required, the high-side does not take it. Close valve A.

- 5) With the unit running, open valve B and add the balance of the charge.

- a. Do not add the liquid refrigerant to the Low-side.

- b. Watch the Low-side gauge; allow pressure to rise to 30 lbs.

- c. Turn off valve B and allow pressure to drop.

- d. Repeat steps b and c until the balance of the charge is in the system.

- 6) When the satisfied the unit is operating correctly, use the pinch-off tool with the unit still running and the clamp on to the pinch-off tube. Using a tube cutter, cut the pinch-off tube about 2 inches from the pinch-off tool. Use sil-fos solder and solder pinch-off tube closed. Turn off the unit, allow it to set for a while, and then test the leakage of the pinch-off connection.

Equipment needed: Vacuum pump, Freon™ Recovery System, Charging cylinder, Manifold gauge, Brazing equipment. Pinch-off tool capable of making a vapor-proof seal, Leak detector, Tubing cutter, Hand Tools to remove components, Service valve.

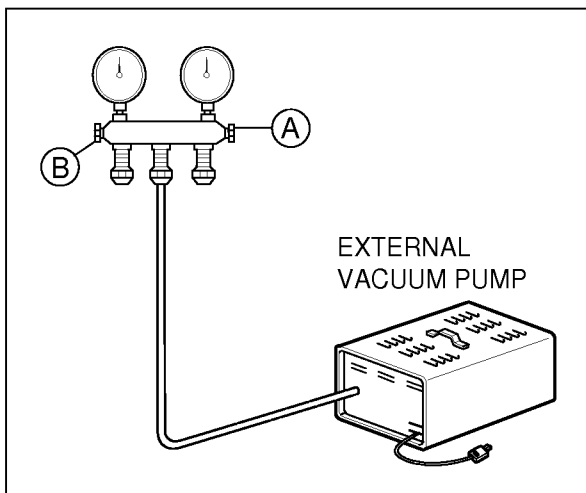
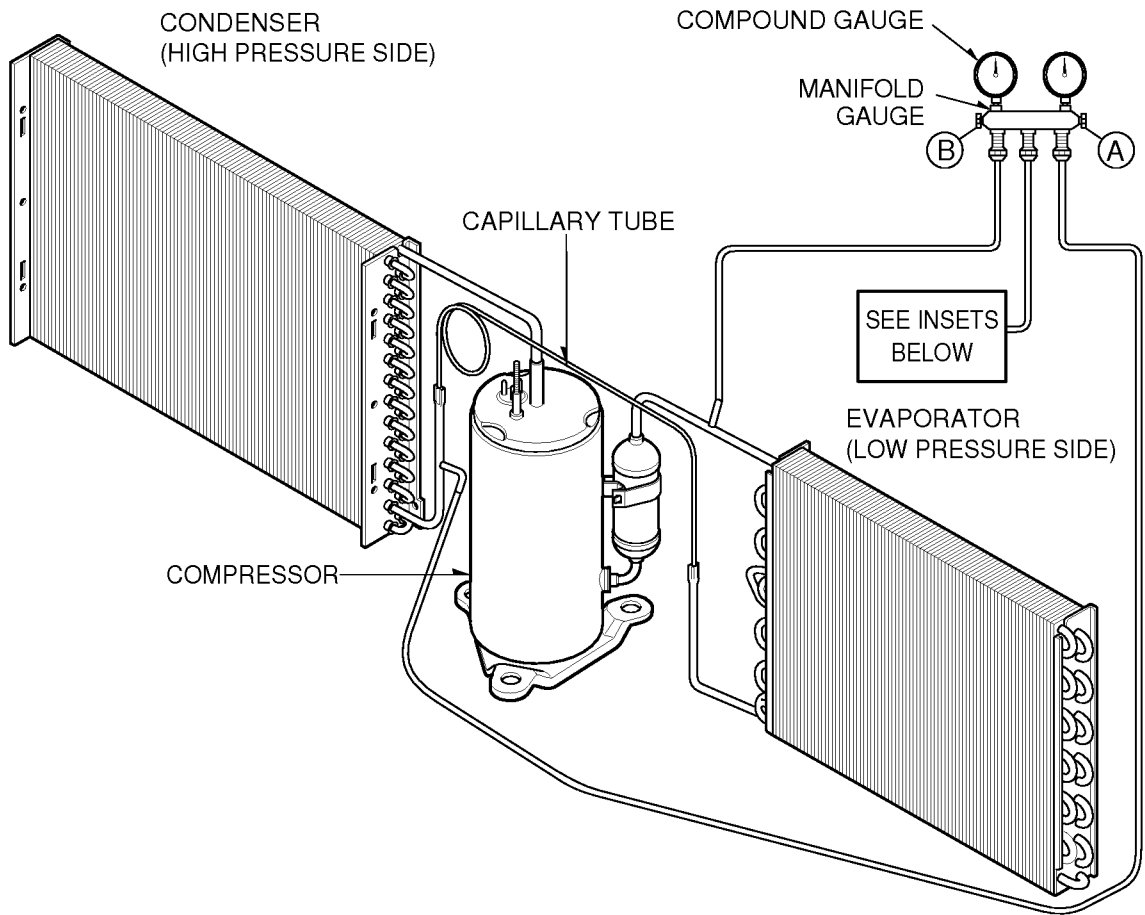

Figure 21A-Pulling Vacuum

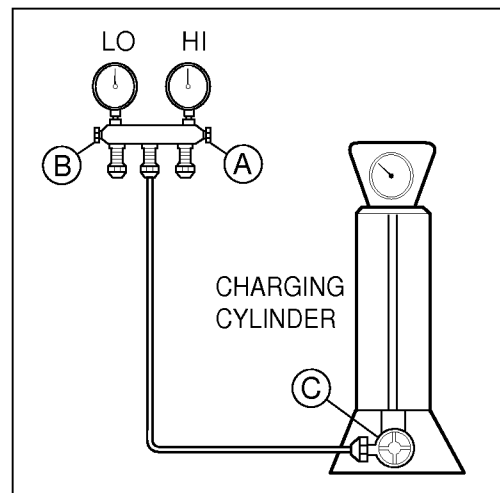
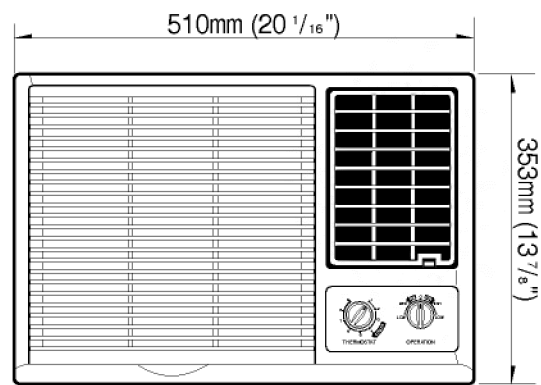
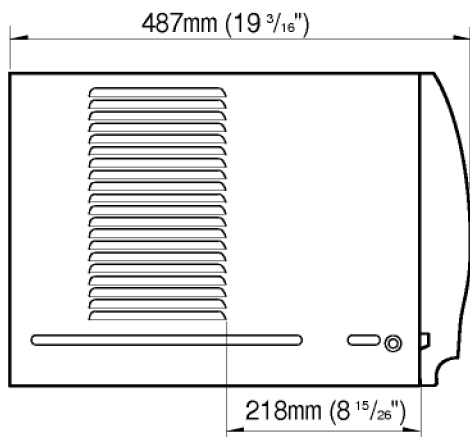
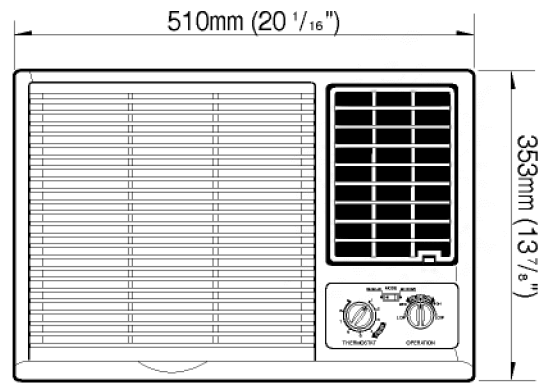
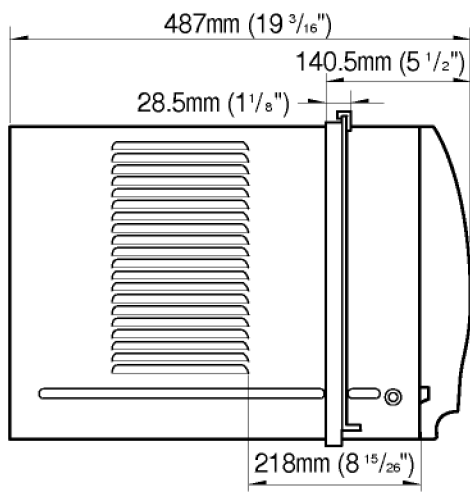

Figure 21B-Charging

4. TROUBLE SHOOTING GUIDE

4.1 OUTSIDE DIMENSIONS



4.2 PIPING SYSTEM

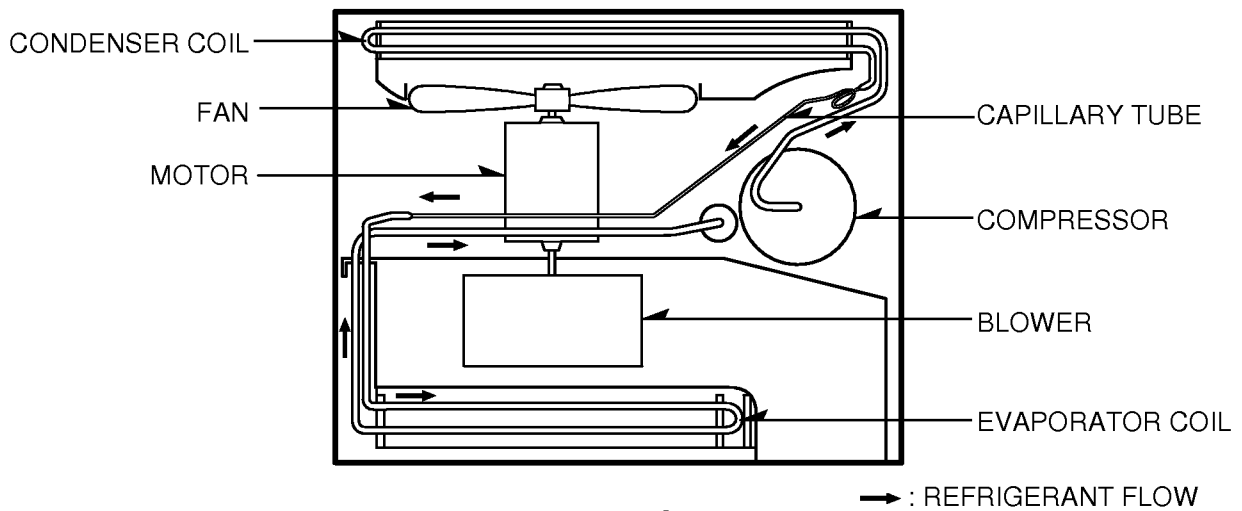

Discharge the refrigerant system using a Freon™ Recovery System. If there is no valve to attach the recovery system, install one (such as a WATCO A-1) before venting the Freon™. Leave the valve in place after servicing the system. Do not vent Freon™ into the atmosphere.

The following is a brief description of the important components and their function in what is called the refrigeration system. Reference should be made to Figure. 31 to follow the refrigerating cycle and the flow of the refrigerant in the cooling cycle.

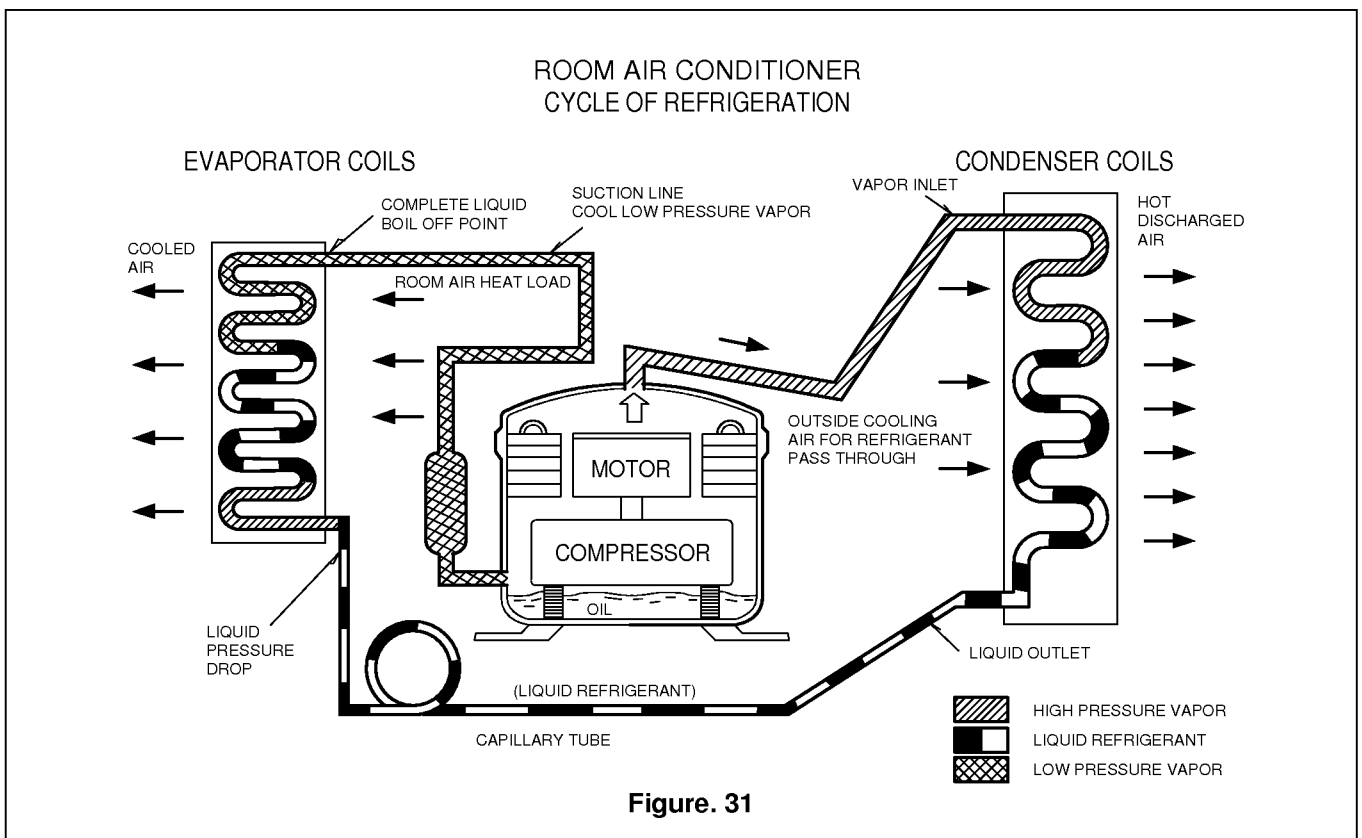

Figure. 31

4.3 TROUBLE SHOOTING GUIDE

In general, possible trouble is classified in two kinds.

The one is so called **Starting Failure** which is caused from an electrical defect. The other is **Ineffective Air Conditioning** caused by a defect in the refrigeration circuit and improper application.

Unit is running but cooling is ineffective.

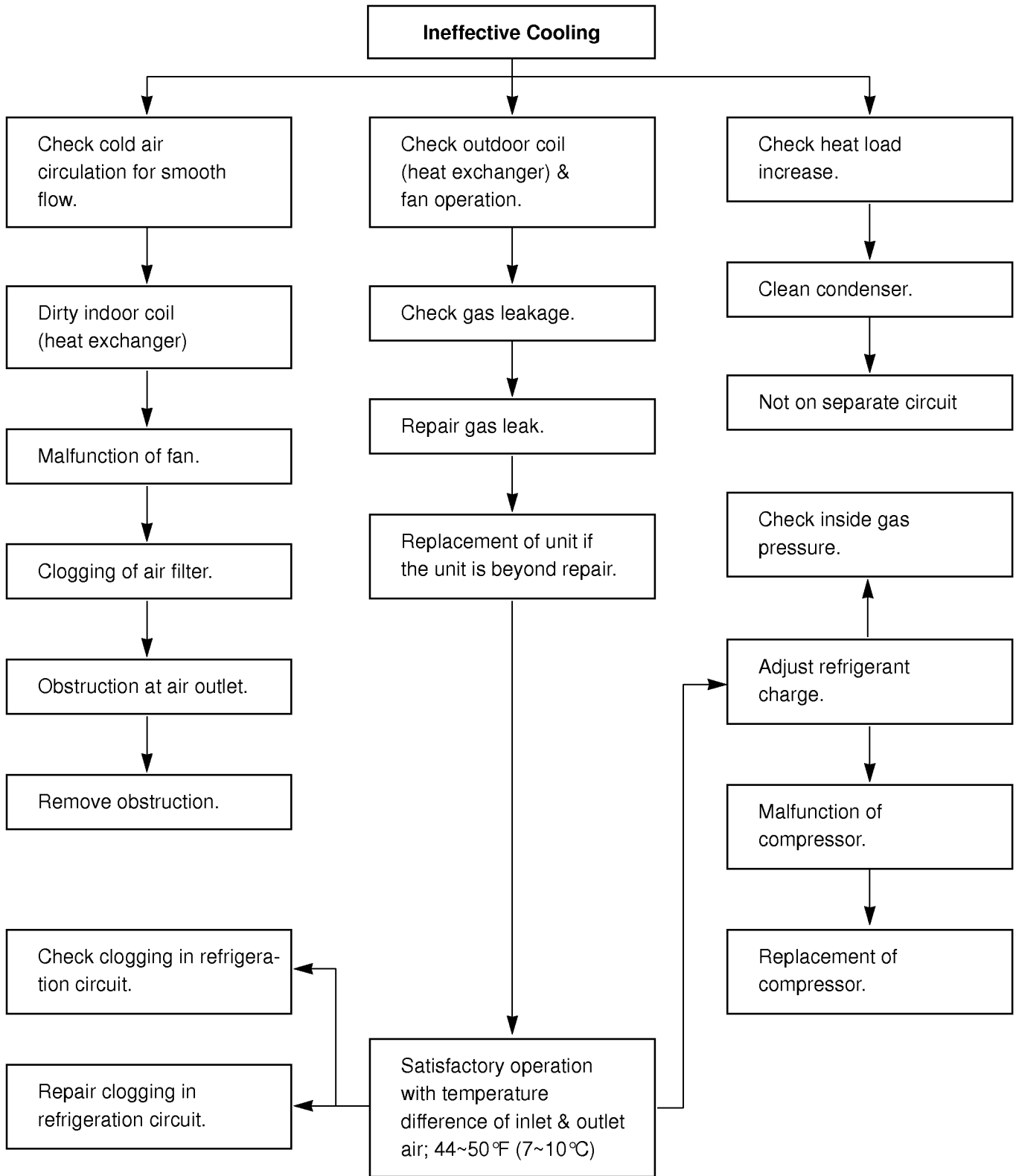

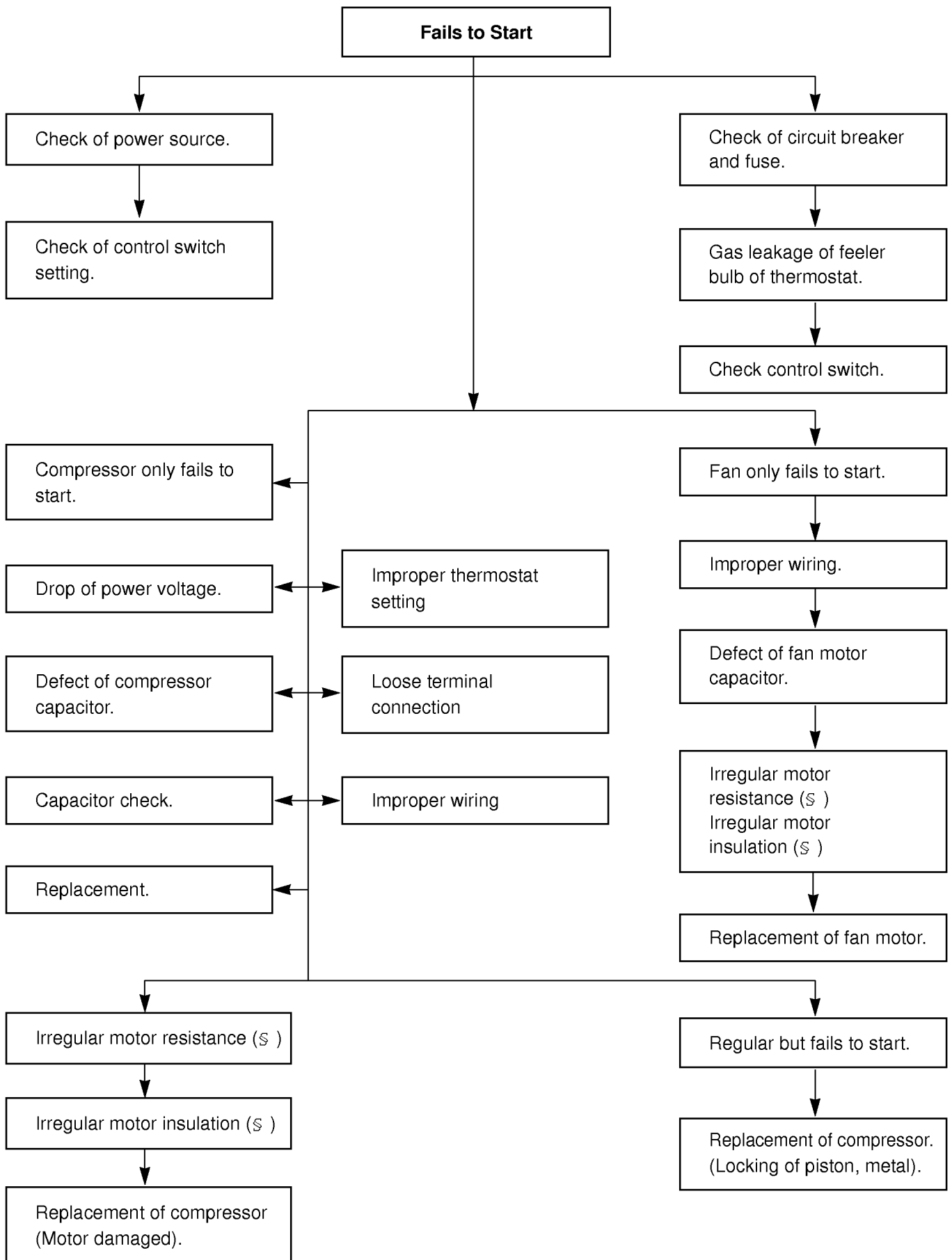

ROOM AIR CONDITIONER VOLTAGE LIMITS

NAME PLATE RATING	MINIMUM	MAXIMUM
115V	103.5V	126.5V
220V~240V	198V	264V
110V	99V	121V

COMPLAINT	CAUSE	REMEDY
Fan motor will not run.	No power	Check voltage at outlet. Correct if none.
	Power supply cord	Check voltage to rotary switch. If none, check power supply cord. Replace cord if circuit is open.
	Rotary switch	Check switch continuity. Refer to wiring diagram for terminal identification. Replace switch if none defective.
	Wire disconnected or connection loose	Connect wire. Refer to wiring diagram for terminal identification. Repair or replace loose terminal.
	Capacitor. (Discharge capacitor before testing.)	Test capacitor. Replace if not within $\pm 10\%$ of manufacturer's rating. Replace if shorted, open, or damaged.
	Will not rotate	Fan blade hitting shroud or blower wheel hitting scroll. Re-align assembly. Units using slinger ring condenser fans must have $\frac{2}{8}$ to $\frac{1}{4}$ inch clearance to the base. If it is the base, shim up the bottom of the fan motor with mounting screw(s). Check fan motor bearings; if motor shaft will not rotate, replace the motor.
Fan motor runs.	Revolves on overload.	Check voltage. See limits on this page. If not within limits, call an electrician. Test capacitor. Check bearings. Does the fan blade rotate freely? If not, replace fan motor. Pay attention to any change from high speed to low speed. If the speed does not change, replace the motor.

COMPLAINT	CAUSE	REMEDY
Fan motor noise.	Fan	If cracked, out of balance, or partially missing, replace it.
	Blower	If cracked, out of balance, or partially missing, replace it.
	Loose set screw	Tighten it.
	Worn bearings	If knocking sounds continue when running or loose, replace the motor. If the motor hums or noise appears to be internal while running, replace motor.
Compressor will not run, fan motor runs.	Voltage	Check voltage. See the limits on the preceding page. If not within limits, call an electrician.
	Wiring	Check the wire connections; if loose, repair or replace the terminal. If the wires are disconnected, refer to wiring diagram for identification, and replace the wires. Check the wire connections; If not according to the wiring diagram, correct the connections.
	Rotary Switch	Check for continuity, refer to the wiring diagram for terminal identification. Replace the switch if the circuit is open.
	Thermostat	Check the position of knob. If not at the coldest setting, advance the knob to this setting and restart the unit.
		Check the continuity of the thermostat. Replace the thermostat if the circuit is open.
	Capacitor (discharge capacitor before servicing.)	Check the capacitor. Replace if not within ; 10% of manufacturer's rating, replace if shorted, open, or damaged.
	Compressor	Check the compressor for open circuit or ground. If open or grounded, replace the compressor.
	Overload	Check the compressor overload, if externally mounted. Replace if open. (If the compressor temperature is high, remove the overload, cool and retest.)
Compressor cycles on overload.	Voltage	Check the voltage. See the limits on the preceding page. If voltage is not within these limits, call an electrician.
	Overload	Check overload, if externally mounted. Replace if open. (If the compressor temperature is high, remove the overload, cool, and retest.)

COMPLAINT	CAUSE	REMEDY
Compressor cycles on overload	Fan motor	If not running, determine the cause. Replace if required.
	Condenser air flow restriction	Remove the cabinet, inspect the interior surface of the condenser. If restricted, clean carefully with a vacuum cleaner (do not damage fins) or brush. Clean the interior base before re-assembling.
	Condenser fins (damaged)	If the condenser fins are closed over a large area on the coil surface, head pressures will increase, causing the compressor to cycle. Straighten the fins or replace the coil.
	Capacitor	Test the capacitor.
	Wiring	Check the terminals. If loose, repair or replace.
	Refrigeration system	Check the system for a restriction.
Insufficient cooling.	Air filter	If restricted, clean or replace.
	Exhaust damper door	Close if open.
	Unit undersized	Determine if the unit is properly sized for the area to be cooled.
Excessive noise.	Blower or fan	Check the set screw, or clamp. If loose or missing, correct. If the blower or fan is hitting scroll or barrier, rearrange the air handling parts.
	Copper tubing	Remove the cabinet and carefully rearrange the tubing not to contact the cabinet, compressor, shroud, and barrier.