

This Owner's Manual is provided and hosted by [Appliance Factory Parts](#).



LG LW-C1211CL Owner's Manual

[Shop genuine replacement parts for LG LW-C1211CL](#)



[Find Your LG Air Conditioner Parts - Select From 2328 Models](#)

----- Manual continues below -----

CONTENTS

1. PREFACE

1.1 SAFETY PRECAUTIONS	2
1.2 INSULATION RESISTANCE TEST	2
1.3 SPECIFICATIONS	3
1.4 FEATURES	6
1.5 CONTROL LOCATIONS	6

2. DISASSEMBLY INTRUCTIONS

2.1 MECHANICAL PARTS	7
2.1.1 FRONT GRILLE	7
2.1.2 CABINET	7
2.1.3 CONTROL BOX	7
2.2 AIR HANDLING PARTS	8
2.2.1 AIR GUIDE	8
2.2.2 BLOWER	8
2.2.3 FAN	8
2.2.4 SHROUD	9
2.3 ELECTRICAL PARTS	9
2.3.1 OVERLOAD PROTECTOR	9
2.3.2 COMPRESSOR	9
2.3.3 CAPACITOR	10
2.3.4 POWER CORD	10
2.3.5 THERMOSTAT	10
2.3.6 ROTARY SWITCH	10
2.3.7 MOTOR	11

2.4 REFRIGERATION CYCLE	11
2.4.1 CONDENSER	11
2.4.2 EVAPORATOR	11
2.4.3 CAPILLARY TUBE	12

3. INSTALLATION

3.1 SELECT THE BEST LOCATIONNN	14
3.2 WINDOW REQUIREMENTS	14
3.3 INSTALLATION KITS CONTENTS	14
3.4 SUGGESTED TOOL REQUIREMENTS	15
3.4.1 PREPARATION OF CHASSIS	15
3.4.2 CABINET INSTALLATION	15

4. TROUBLE SHOOTING GUIDE

4.1 OUTSIDE DIMENSION	17
4.2 PIPING SYSTEM	18
4.3 TROUBLE SHOOTING GUIDE	19

5. SCHEMATIC DIAGRAM

5.1 CIRCUIT DIAGRAM	24
5.2 ELECTRONIC CONTROL DEVICE	27
5.3 COMPONENTS LOCATION (OF MAIN P.C.B ASM)	28
5.4 COMPONENTS LOCATION (FOR DISPLAY P.C.B ASM)	28

6. EXPLODED VIEW

7. REPLACEMENT PARTS LIST

1. PREFACE

This **service manual** provides various service information, including the mechanical and electrical parts etc. This room air conditioner was manufactured and assembled under strict quality control system. The refrigerant is charged at the factory. Be sure to read the safety precautions prior to servicing the unit.

1.1 SAFETY PRECAUTIONS

1. When servicing the unit, set the ROTARY SWITCH or POWER SWITCH to OFF and unplug the power cord.
2. Observe the original lead dress.
If a short circuit is found, replace all parts which have been overheated or damaged by the short circuit.
3. After servicing the unit, make an insulation resistance test to protect the customer from being exposed to shock hazards.

1.2 INSULATION RESISTANCE TEST

1. Unplug the power cord and connect a jumper between 2 pins (black and white).
2. The grounding conductor (green) is to be open.
3. Measure the resistance value with an ohm meter between the jumpered lead and each exposed metallic part on the equipment at all the positions (except OFF) of the ROTARY SWITCH.
4. The value should be over 1MΩ.

1.3 SPECIFICATIONS

1.3.1 FOR LW-C1211CL/C1011CL/C1210CL/C1010CL

ITEMS		MODELS	LW-C1211CL	LW-C1011CL	LW-C1210CL	LW-C1010CL
POWER SUPPLY		1 ϕ , 115V, 60Hz				
COOLING CAPACITY	(BTU/h)	12,000	10,000	12,000	10,000	
INPUT	(W)	1,260	1,000	1,330	1,110	
RUNNING CURRENT	(A)	11.5	9.2	12	9.5	
E.E.R	(BTU/W.h)	9.5	10.0	9.0	9.0	
REFRIGERANT (R-22) CHARGE	(g)	670	610	650	550	
OPERATING TEMPERATURE	INDOOR (°C)	26.7 (DB)		19.4 (WB)		
	OUTDOOR (°C)	35 (DB)		23.9 (WB)		
EVAPORATOR		2 ROW 13 STACKS, LOUVERED-FIN TYPE				
CONDENSER		2 ROW 14 STACKS, LOUVERED-FIN TYPE				
FAN, INDOOR		BLOWER				
FAN, OUTDOOR		PROPELLER TYPE FAN WITH SLINGER-RING				
FAN SPEEDS, FAN/COOLING		2/3				
FAN MOTOR		6POLES				
OPERATION CONTROL		ROTARY SWITCH				
ROOM TEMP. CONTROL		THERMOSTAT				
AIR DIRECTION CONTROL		VERTICAL LOUVER (RIGHT & LEFT)				
		HORIZONTAL LOUVER (UP & DOWN)				
CONSTRUCTION		SLIDE IN-OUT CHASSIS				
PROTECTOR	COMPRESSOR	OVERLOAD PROTECTOR				
	FAN MOTOR	INTERNAL THERMAL PROTECTOR				
POWER CORD		1.8m (3 WIRE WITH GROUDING)				
		ATTACHMENT PLUG (CORD-CONNECTED TYPE)				
DRAIN SYSTEM		DRAIN PIPE OR SPLASHED BY FAN SLINGER				
NET WEIGHT	(lbs/kg)	95/43	90/41	95/43	90/41	
OUTSIDE DIMENSION (W ; H ; D)	(inch)	23 ⁵ / ₈ ; 14 ³¹ / ₃₂ ; 21 ²⁶ / ₃₂				
	(mm)	600 ; 380 ; 555				

1.3.2 FOR LW-C1230CL/C1030CL/C1231CL/C1031CL

ITEMS		MODELS	LW-C1230CL	LW-C1030CL	LW-C1231CL	LW-C1031CL
POWER SUPPLY		1ϕ, 208-230V, 60Hz				
COOLING CAPACITY	(BTU/h)	12,000	10,000	12,000	10,000	
INPUT	(W)	1,300	1,050	1,300	1,050	
RUNNING CURRENT	(A)	6.2	5.0	6.2	5.0	
E.E.R	(BTU/W.h)	9.2	9.5	9.2	9.5	
REFRIGERANT (R-22) CHARGE	(g)	630	650	630	650	
OPERATING TEMPERATURE	INDOOR (°C)	27 (DB)		19.5 (WB)		
	OUTDOOR (°C)	35 (DB)		24 (WB)		
EVAPORATOR		2 ROW 13 STACKS, LOUVERED-FIN TYPE				
CONDENSER		2 ROW 14 STACKS, LOUVERED-FIN TYPE				
FAN, INDOOR		BLOWER				
FAN, OUTDOOR		PROPELLER TYPE FAN WITH SLINGER-RING				
FAN SPEEDS, FAN/COOLING		2/3		2/2		
FAN MOTOR		6POLES				
OPERATION CONTROL		ROTARY SWITCH		WIRELESS REMOCON		
ROOM TEMP. CONTROL		THERMOSTAT		THERMISTOR		
AIR DIRECTION CONTROL		VERTICAL LOUVER (RIGHT & LEFT)				
		HORIZONTAL LOUVER (UP & DOWN)				
CONSTRUCTION		SLIDE IN-OUT CHASSIS				
PROTECTOR	COMPRESSOR	OVERLOAD PROTECTOR				
	FAN MOTOR	INTERNAL THERMAL PROTECTOR				
POWER CORD		1.8m (3 WIRE WITH GROUDING)				
		ATTACHMENT PLUG (CORD-CONNECTED TYPE)				
DRAIN SYSTEM		DRAIN PIPE OR SPLASHED BY FAN SLINGER				
NET WEIGHT	(lbs/kg)	95/43	90/41	95/43	90/41	
OUTSIDE DIMENSION (W i¿H i¿D)	(inch)	23 ⁵ / ₈ i¿14 ³¹ / ₃₂ i¿21 ²⁶ / ₃₂				
	(mm)	600 i¿380 i¿555				

1.3.3 FOR LW-C1260CL/C1261CL

ITEMS		MODELS	LW-C1260CL	LW-C1261CL
POWER SUPPLY			1ϕ, 220/240V, 50Hz	
COOLING CAPACITY		(BTU/h)	12,000	
INPUT		(W)	1,260	
RUNNING CURRENT		(A)	5.3	
E.E.R		(BTU/W.h)	9.5	
REFRIGERANT (R-22) CHARGE		(g)	650	
OPERATING TEMPERATURE	INDOOR	(°C)	27 (DB)	19 (WB)
	OUTDOOR	(°C)	35 (DB)	24 (WB)
EVAPORATOR			2 ROW 13 STACKS, LOUVERED-FIN TYPE	
CONDENSER			2 ROW 14 STACKS, LOUVERED-FIN TYPE	
FAN, INDOOR			BLOWER	
FAN, OUTDOOR			PROPELLER TYPE FAN WITH SLINGER-RING	
FAN SPEEDS, FAN/COOLING			2/3	2/2
FAN MOTOR			6POLES	
OPERATION CONTROL			ROTARY SWITCH	WIRELESS REMOCON
ROOM TEMP. CONTROL			THERMOSTAT	THERMISTOR
AIR DIRECTION CONTROL			VERTICAL LOUVER (RIGHT & LEFT)	
			HORIZONTAL LOUVER (UP & DOWN)	
CONSTRUCTION			SLIDE IN-OUT CHASSIS	
PROTECTOR	COMPRESSOR		OVERLOAD PROTECTOR	
	FAN MOTOR		INTERNAL THERMAL PROTECTOR	
POWER CORD			1.8m (3 WIRE WITH GROUDING)	
			ATTACHMENT PLUG (CORD-CONNECTED TYPE)	
DRAIN SYSTEM			DRAIN PIPE OR SPLASHED BY FAN SLINGER	
NET WEIGHT		(lbs/kg)	95/43	
OUTSIDE DIMENSION (W i¿H i¿D)		(inch)	23 ⁵ / ₈ i¿14 ³¹ / ₃₂ i¿21 ²⁶ / ₃₂	
		(mm)	600 i¿380 i¿555	

1.4 FEATURES

- Designed for cooling only.
- Powerful and quiet cooling.
- Slide-in, and slide-out chassis for the simple installation and service.
- Side air-intake, side cooled-air discharge.
- Built in adjustable THERMOSTAT.
- Washable one-touch filter.
- Compact size.
- Reliable and efficient rotary compressor is equipped.

1.5 CONTROL LOCATIONS

1.5.1 COOLING ONLY MODEL

• VENTILATION

The ventilation lever must be CLOSE position in order to maintain the best cooling conditions.

When a fresh air is necessary in the room, set the ventilation lever OPEN position.

The damper is opened and room air is exhausted.

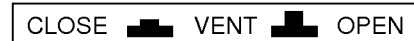
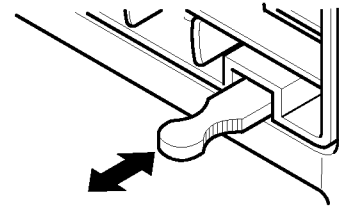

• MODE (ENERGY SAVER)

Energy saver provides more energy efficient operation of the air conditioner by cycling the fan on and off with compressor.

REGULAR : Energy saver is not operated.

ECONOMY : Energy saver is operated.

(FOR LW-C1011CL, LW-C1211CL)

• THERMOSTAT

Thermostat will automatically control the temperature of the room. Select the higher number for the lower temperature of the room. The temperature is selected by positioning the knob to the desired position.

The 5 or 6 position is a normal setting for average conditions.

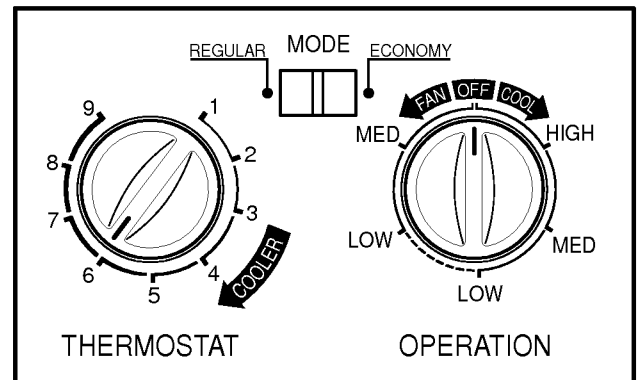

• OPERATION

OFF (○) : Turns the air conditioner off.

MED FAN (⊗) : Permits the medium fan speed operation without cooling.

LOW FAN (⊕) : Permits the low fan speed operation without cooling.

HIGH COOL (❄️) : Permits cooling with the high fan speed operation.

MED COOL (❄️) : Permits cooling with the medium fan speed operation.

LOW COOL (❄️) : Permits cooling with the low fan speed operation.

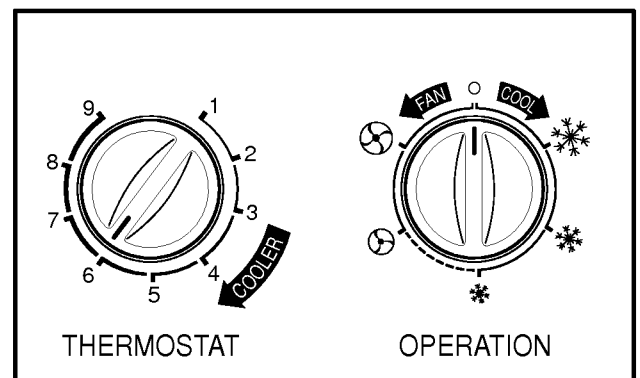

2. DISASSEMBLY INSTRUCTIONS

- Before the following disassembly, POWER SWITCH the set to OFF and disconnect the power cord.

2.1 MECHANICAL PARTS

2.1.1 FRONT GRILLE

1. Open the Inlet grille upward and remove the air filter.
2. Remove the screw which fastens the front grille.
3. Pull the front grille from the right side.
4. Remove the front grille.
5. Re-install the component by referring to the removed procedure, above. (See figure 1)

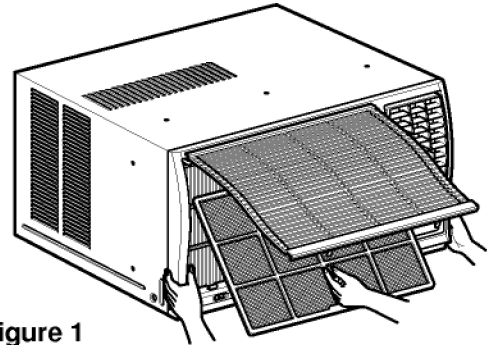

Figure 1

2.1.2 CABINET

1. After disassembling the FRONT GRILLE, remove the screws which fasten the cabinet at both sides.
2. Remove the two screws which fastens the cabinet at back.
3. Pull the base pan forward. (See figure 2)

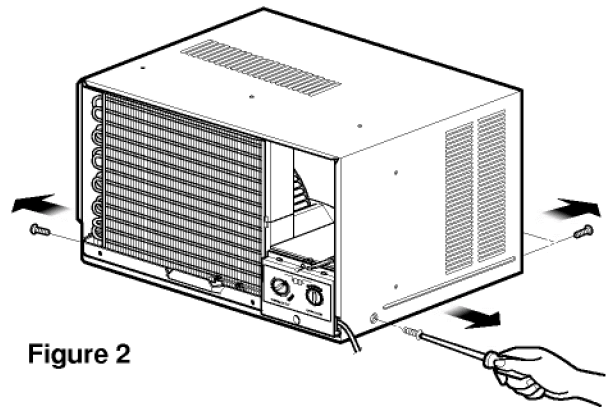

Figure 2

2.1.3 CONTROL BOX

1. Remove the front grille. (Refer to section 2.1.1)
2. Remove the 3 screws which fasten the control box.
3. Pull the control box forward about 10-15cm.
4. Discharge the capacitor by placing a 20,000 ohm resistor across the capacitor terminals.
5. Remove two wire housings in the control box.
6. Pull the control box forward completely.
7. Re-install the components by referring to the removed procedure, above. (See figure 3)
(Refer to the circuit diagram found on page 24 in this manual and on the control box.)

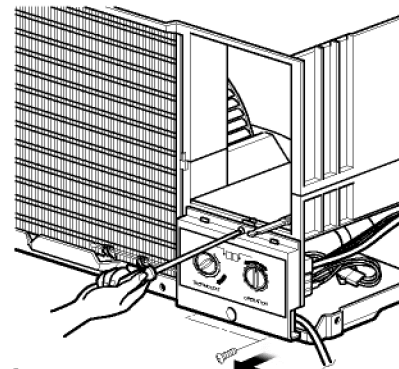

Figure 3

2.2 AIR HANDLING PARTS

2.2.1 AIR GUIDE

1. Remove the front grille. (Refer to section 2.1.1)
2. Remove the cabinet. (Refer to section 2.1.2)
3. Remove 4 screws which fasten the brace.
4. Remove the brace.
5. Remove 2 screws which fasten the air guide.
6. Lift the upper air guide. Upward.
7. Re-install the components by referring to the removed procedure, above. (See figure 4)

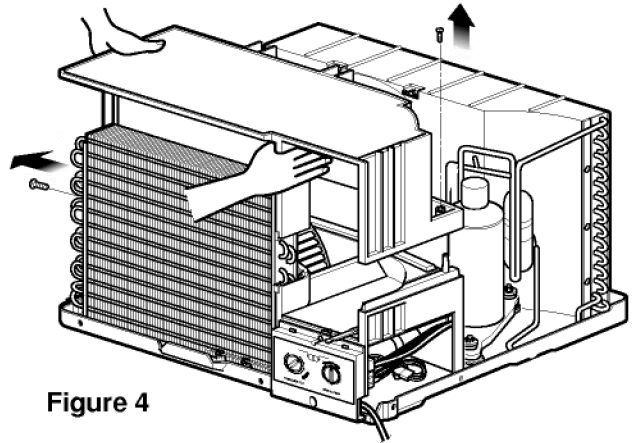

Figure 4

2.2.2 BLOWER

1. Remove the air guide. (Refer to section 2.2.1)
2. Remove the screw which fastens the evaporator.
3. Move the evaporator sideward carefully.
4. Remove the clamp with hand plier which secures the blower. (See figure 5)
5. Remove 2 screws which fasten the motor mount.
6. Pull the blower forward with dragging the motor mount upward carefully.
7. Remove the blower.
8. Re-install the components by referring to the removed procedure, above. (See figure 6)

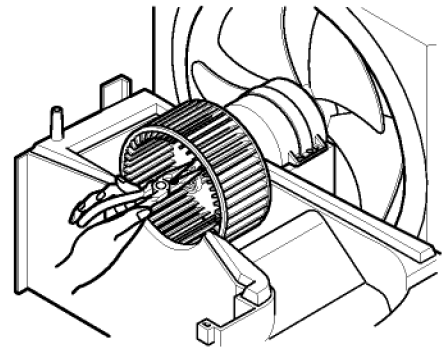

Figure 5

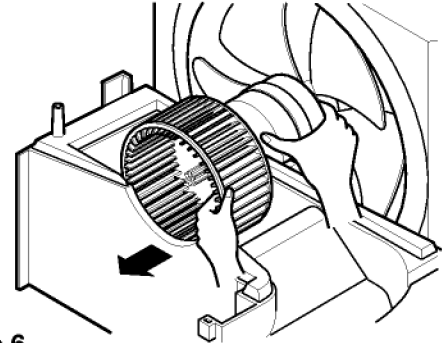

Figure 6

2.2.3 FAN

1. Remove the cabinet. (Refer to section 2.1.2)
2. Remove the brace (Refer to section 2.2.1)
3. Remove the 5 screws which fasten the condenser.
4. Remove the screw which fastens the shroud.
5. Move the condenser sideward carefully.
6. Remove the clamp which secures the fan.
7. Remove the fan.
8. Re-install by referring to the removed procedure, above. (See figure 7)

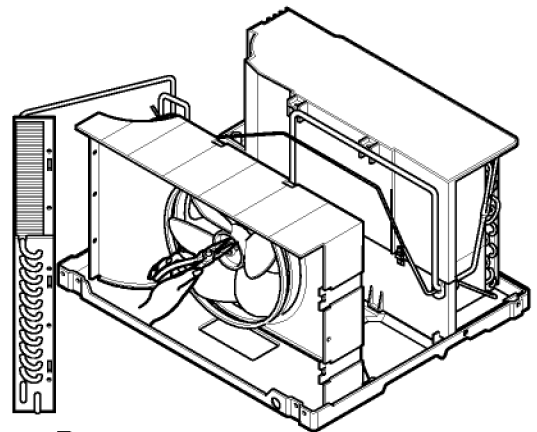

Figure 7

2.2.4 SHROUD

1. Remove the fan. (Refer to section 2.1.3)
2. Remove the screw which fastens the shroud.
3. Remove the fan. (Refer to section 2.2.3)
4. Remove the shroud. (See figure 8)
5. Re-install the component by referring to the removed procedure, above.

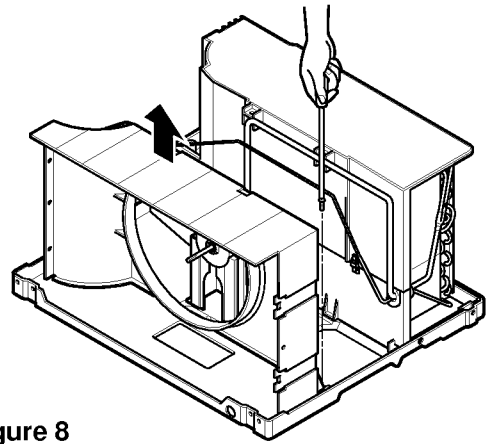

Figure 8

2.3 ELECTRICAL PARTS

2.3.1 OVERLOAD PROTECTOR

1. Remove the cabinet. (Refer to section 2.1.2)
2. Remove the nut which fastens the terminal cover.
3. Remove the terminal cover.
4. Remove all the leads from the overload protector.
5. Remove the over load protector.
6. Re-install the component by referring to the removed procedure, above. (See figure 9)

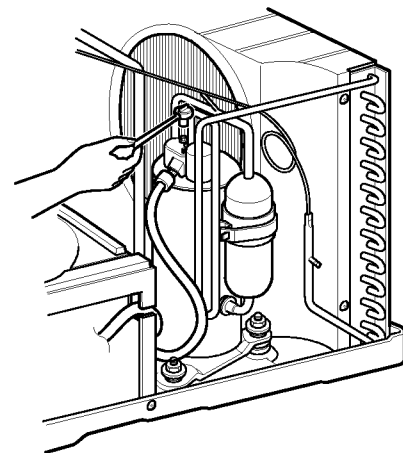

Figure 9

2.3.2 COMPRESSOR

1. Remove the cabinet. (Refer to section 2.1.2)
2. Discharge the refrigerant system using a Freon™ Recovery System.
If there is no valve to attach the recovery system, install one (such as a WATCO A-1) before venting the Freon™. Leave the valve in place after servicing the system.
3. Remove the overload protector. (Refer to section 2.3.1)
4. After purging the unit completely, unbraid the suction and discharge tube at the compressor connections.
5. Remove the 3 nuts and the 3 washers which fasten the compressor.
6. Remove the compressor.
7. Re-install the components by referring to the removed procedure, above. (See figure 10)

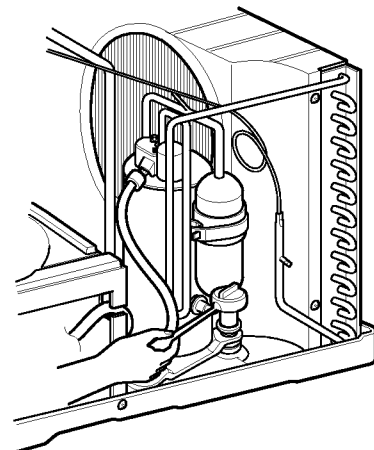

Figure 10

2.3.3 CAPACITOR

1. Remove the control box. (Refer to section 2.1.3)
2. Remove the screw and the clamp which fastens the capacitor.
3. Disconnect all the leads of capacitor terminals.
4. Re-install the components by referring to the removed procedure, above. (See figure 11)

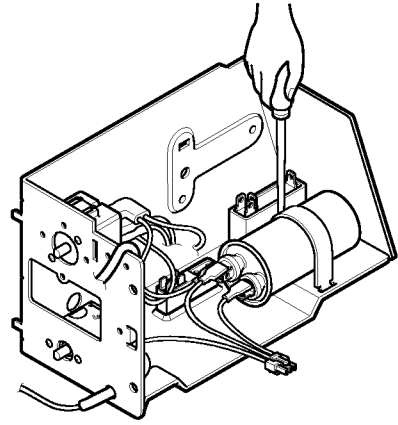

Figure 11

2.3.4 POWER CORD

1. Remove the control box. (Refer to section 2.1.3)
2. Disconnect the grounding screw from the control box.
3. Disconnect 2 receptacles.
4. Remove a screw which fastens the clip cord.
5. Pull the power cord. (See to figure 12)
6. Re-install the component by referring to the removed procedure, above.
(Use only one earth-marked \oplus hole for earthconnection.)
7. If the supply cord of this appliance is damaged, it must be replaced by the special cord. (The special cord means the cord which has the same specification marked on the supply cord fitted to the unit.)

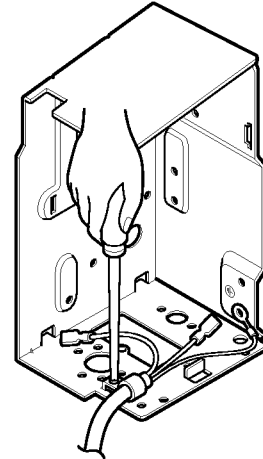

Figure 12

2.3.5 THERMOSTAT

1. Remove the control box. (Refer to section 2.1.3)
2. Remove the screw which fasten the display panel.
3. Remove the two knobs.
4. Remove the display panel.
5. Remove 2 screws which fasten the thermostat.
6. Disconnect all the leads of thermostat terminals.
7. Remove the thermostat.
8. Re-install the components by referring to the removed procedure, above. (See figure 13)

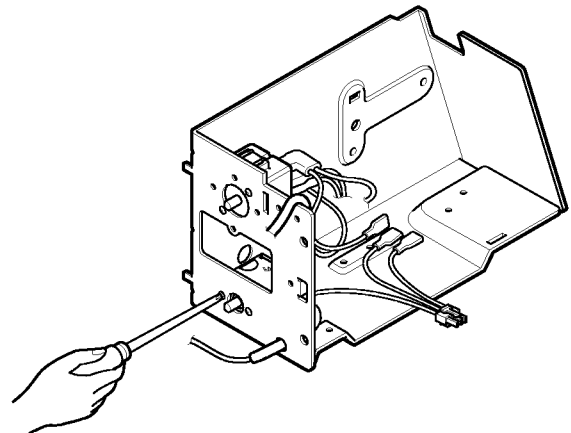

Figure 13

2.3.6 ROTARY SWITCH

1. Remove the control box. (Refer to section 2.1.3)
2. Remove the screw which fastens the display panel.
3. Remove the two knobs.
4. Remove the display panel.
5. Remove 2 screws which fasten the rotary switch.
6. Disconnect all the leads of the rotary switch terminals.
7. Remove the rotary switch.
8. Re-install the components by referring to the removed procedure, above. (See figure 14)

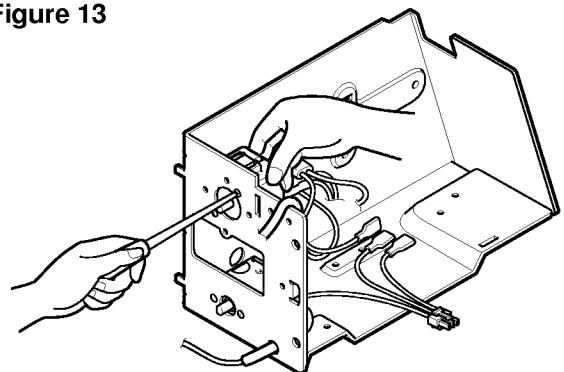

Figure 14

2.3.7 MOTOR

1. Remove the cabinet. (Refer to section 2.1.2)
2. Remove the air guide. (Refer to section 2.2.1)
3. Remove the blower. (Refer to section 2.2.2)
4. Remove the fan. (Refer to section 2.2.3)
5. Remove the shroud. (Refer to section 2.2.4)
6. Remove the control box. (Refer to section 2.1.3)
7. Remove the 2 screws which fasten the motor clamp.
8. Remove the motor.
9. Re-install the components by referring to the removed procedure, above. (See figure 15)

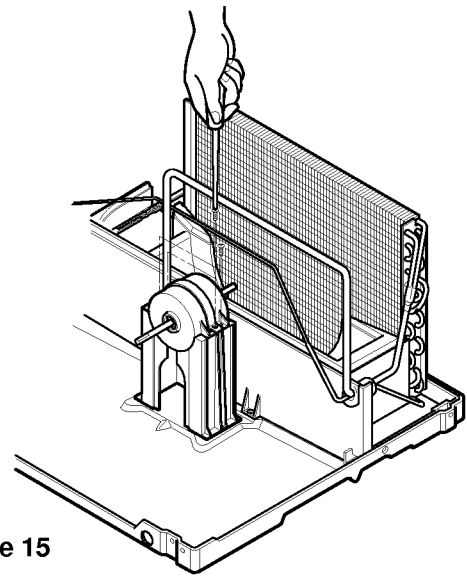

Figure 15

2.4 REFRIGERATION CYCLE

CAUTION

Discharge the refrigerant system using a Freon™ Recovery System. If there is no valve to attach the recovery system, install one (such as a WATCO A-1) before venting the Freon™. Leave the valve in place after servicing the system.

2.4.1 CONDENSER

1. Remove the cabinet. (Refer to section 2.1.2)
2. Remove the 5 screws which fasten the condenser.
3. Remove the 4 screws which fasten the brace.
4. After discharging the refrigerant completely, unbraid the interconnecting tube at the condenser connections.
5. Remove the condenser.
6. Re-install the component by referring to notes. (See figure 16)

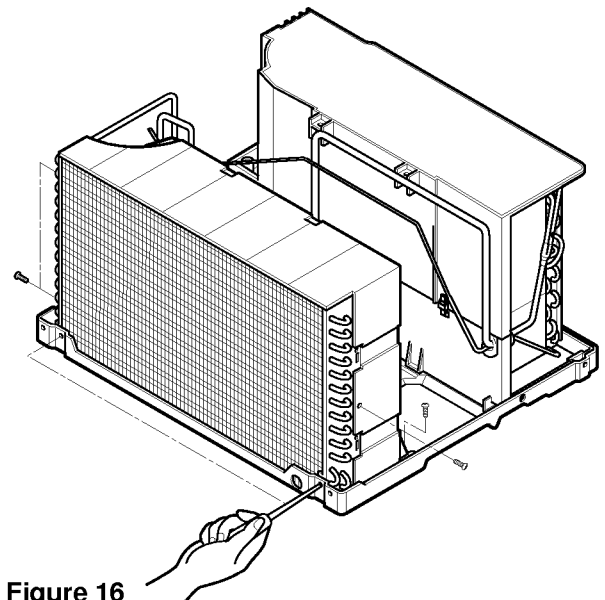

Figure 16

2.4.2 EVAPORATOR

1. Remove the cabinet. (Refer to section 2.1.2)
2. Remove the air guide. (Refer to section 2.2.1)
3. After discharging the refrigerant completely.
4. Unbraid the interconnecting tube at the evaporator connections.
5. Remove the screw which fasten the evaporator.
6. Remove the evaporator.
7. Re-install the component by referring to notes. (See figure 17)

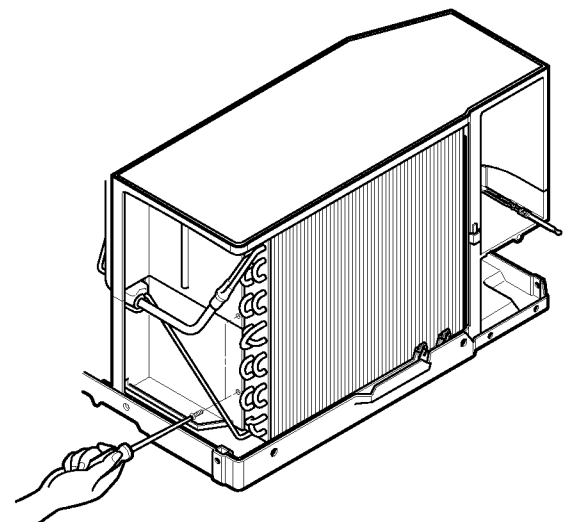

Figure 17

2.4.3 CAPILLARY TUBE

1. Remove the cabinet. (Refer to section 2.1.2)
2. Remove the air guide. (Refer to section 2.2.1)
3. After dischargingg the refrigerant completely, unbrazed the interconnecting tube at the capillary tube.
4. Remove the capillary tube.
5. Re-install the component by referring to notes.

NOTES

– Replacement of the refrigeration cycle.

1. When replacing the refrigeration cycle, be sure to Discharge the refrigerant system using a Freom™ Recovery System.
If there is no valve to attach the recovery system, install one (such as a WATCO A-1) before venting the Freon™. Leave the valve in place after servicing the system.
2. After discharge the unit completely, remove the desired component, and unbrazed the pinch-off tubes.
3. Solder service valves into the pinch-off tube ports, leaving the valves open.
4. Solder the pinch-off tubes with Service valves.
5. Evacuate as follows.
 - 1) Connect the vacuum pump, as illustrated Figure 18A.
 - 2) Start the vacuum pump, slowly open manifold valves A and B with two full turns counter-clockwise and leave the valves closed.
The vacuum pump is now pulling through valves A and B up to valve C by means of the manifold and entire system.
6. Recharge as follows :
 - 1) Refrigeration cycle systems are charged from the High-side. If the total charge cannot be put in the High-side, the balance will be put in the suction line through the access valve which you install as the system is opened.
 - 2) Connect the charging cylinder as shown in figure 18B.
With valve C open discharge the hose at the manifold connection.
 - 3) Open valve A and allow proper charge to enter the system. Valve B is still closed.
 - 4) If more charge is required, the high-side does not take it. Close valve A.
 - 5) With the unit running, open valve B and add the balance of the charge.
 - a. Do not add the liquid refrigerant to the Low-side.
 - b. Watch the Low-side gauge, allow pressure to rise to 30 lbs.
 - c. Turn off valve B and allow pressure to drop.
 - d. Repeat steps B and C until the balance of the charge is in the system.
 - 6) When the satisfactory unit is operating correctly, use the pinch-off tool with the unit still running and clamp on to the pinch-off tube. Using a tube cutter, cut the pinch-off tube about 2 inches from the pinch-off tool. Use sil-fos solder and solder pinch-off tube closed. Turn off the unit, allow it to set for a while, and then test the leakage of the pinch-off connection.

CAUTION

If high vacuum equipment is used, just crack valves A and B for a few minutes, then open slowly with the two full turns counter-clockwise. This will keep oil from foaming and being drawn into the vacuum pump.

Equipment needed: Vacuum pump, Charging cylinder, Manifold gauge, Brazing equipment. Pinch-off tool capable of making a vapor proof seal, Leak detector, Tubing cutter, Hand tools to remove components, Service valve.

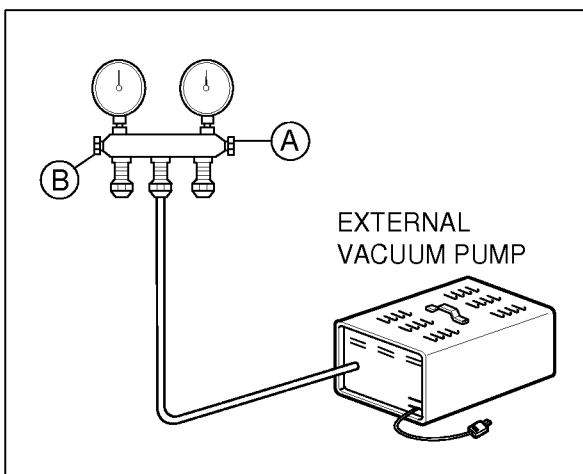
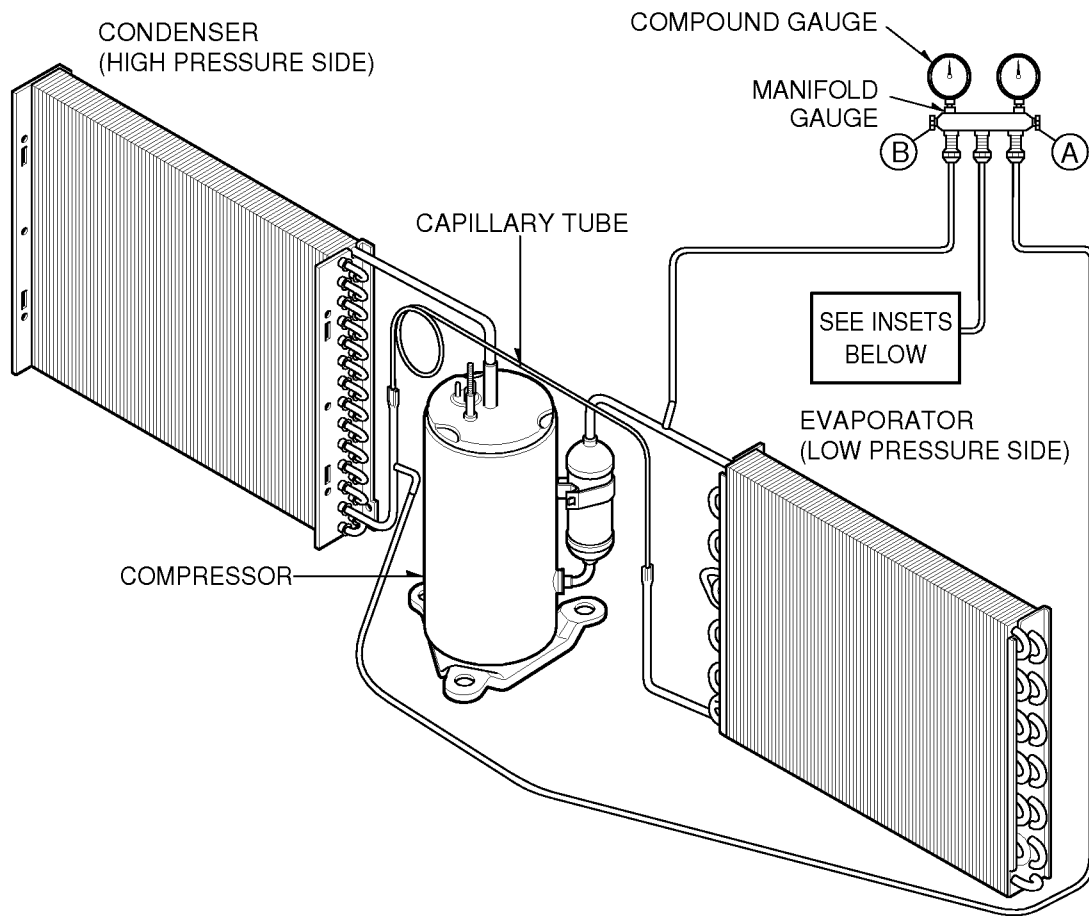

Figure 18A-Pulling Vacuum

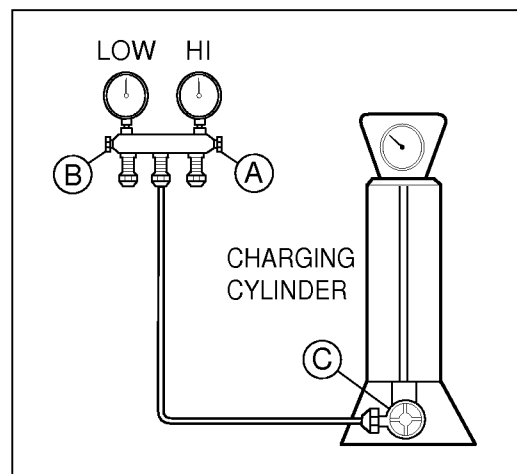

Figure 18B-Charging

3. INSTALLATION

3.1 SELECT THE BEST LOCATION

1. To prevent vibration and noise, make sure the unit is installed securely and firmly.
2. Install the unit where the sunlight does not shine directly on the unit.
3. The outside of the cabinet must extend outward for at least 10" and there should be no obstacles, such as a fence or wall, within 20" from the back of the cabinet because it will prevent heat radiation of the condenser.
Restriction of outside air will greatly reduce the cooling efficiency of the air conditioner.

CAUTION
All side louvers of the cabinet must remain exposed to the outside of the structure.

4. Install the unit a little slanted so the back is slightly lower than the front (about 1/2"). This will force condensed water to the outside.
5. Install the unit with the bottom about 30"~60" above the floor level.

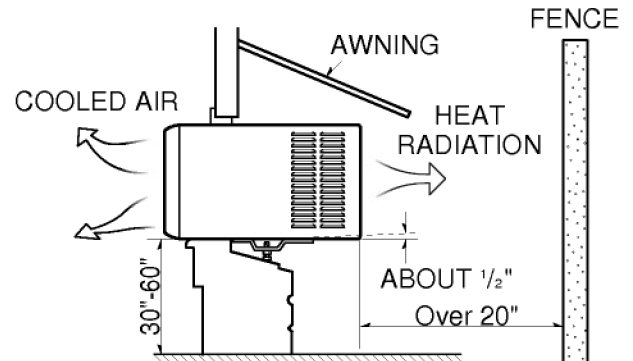

3.2 WINDOW REQUIREMENTS

1. This unit is designed for installation in standard double hung windows with actual opening widths from 24" to 32".
The top and bottom window sash must open sufficiently to allow a clear vertical opening of 16" from the bottom of the upper sash to the window stool.
The stool offset (height between the stool and sill) must be less than 1-1/2".
2. The stool offset (height between the stool and sill) must be less than 1-1/2".

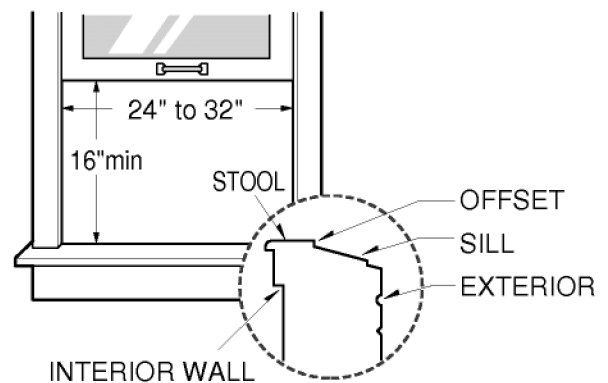

3.3 INSTALLATION KITS CONTENTS

NO.	NAME OF PARTS	Q'TY
1	GUIDE PANEL	2
2	FILLER PANEL	6
3	SILL SUPPORT	2
4	BOLT	2
5	NUT	2
6	SCREW (TYPE A)	11
7	SCREW (TYPE B)	5
8	FOAM-PU	1
9	FOAM-STRIP	1
10	UPPER GUIDE	1
11	SIDE RETAINER	2
12	DRAIN PIPE	1

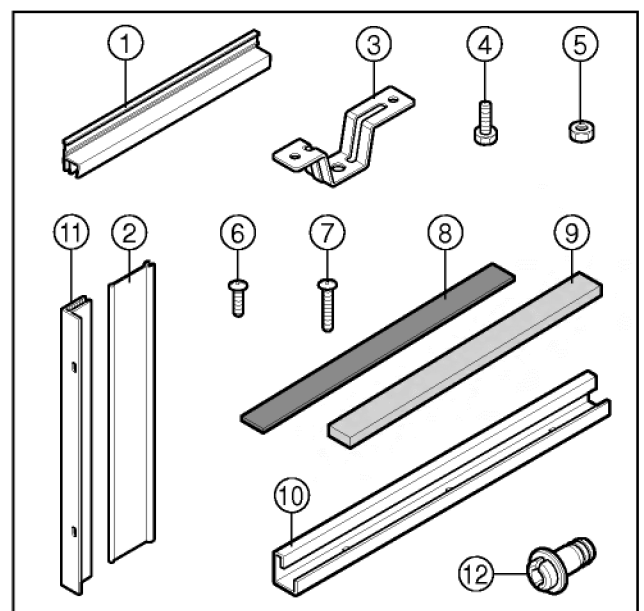

window stool (or desired air conditioner location). Carefully place the cabinet on the window stool and align the center mark on the bottom front with the center line marked in the window stool.

2. Pull the bottom window sash down behind the upper guide until they meet.

NOTES

1. Cut the foam-strip to the same length as window width and put it on the guide panel before step 2.
2. Do not pull the window sash down so tightly that the movement of guide panel is restricted.

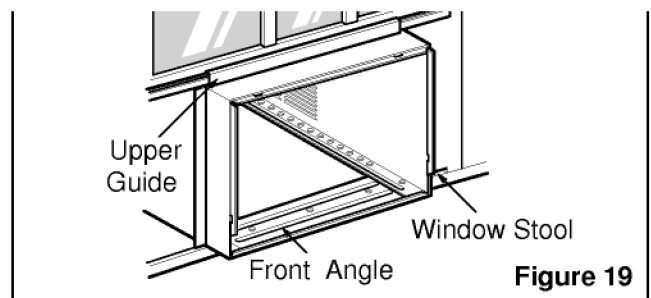

Figure 19

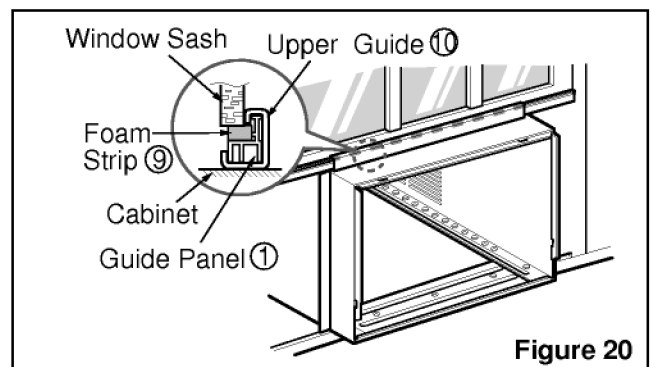

Figure 20

13. Slide the chassis into the cabinet.

(See figure 26)

CAUTION

For security purpose, reinstall screws at cabinet's sides.

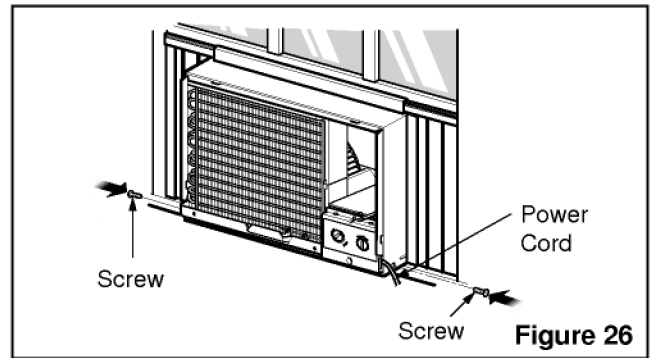

14. Cut the foam-strip to the proper length and insert between the upper window sash and the lower window sash.

(See figure 27)

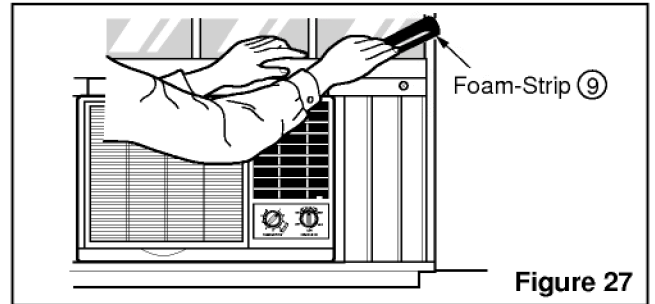

15. After installing the unit back into the cabinet, there will be an air gap between the bottom of the unit and the window sill. Use the foam-strip \times or foam-pu \times provided to fill in the opening.

16. Assemble the front grille with the cabinet.

(See figure 28)

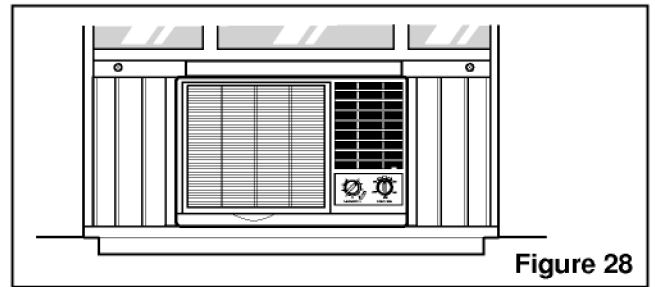

4. TROUBLE SHOOTING GUIDE

4.1 OUTSIDE DIMENSIONS (unit: mm)

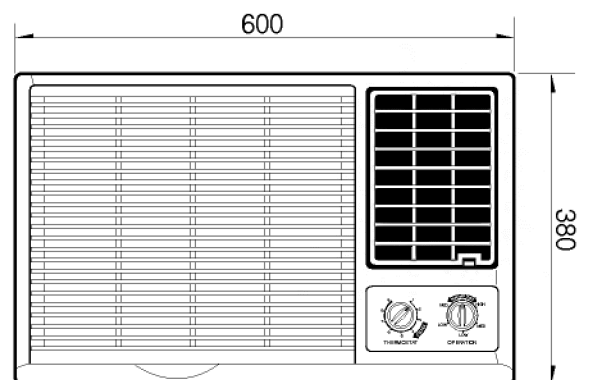
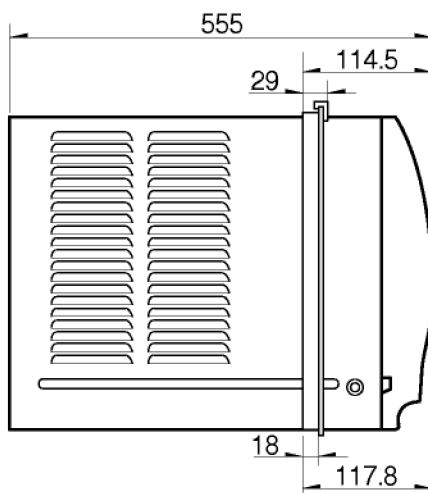

4.2 PIPING SYSTEM

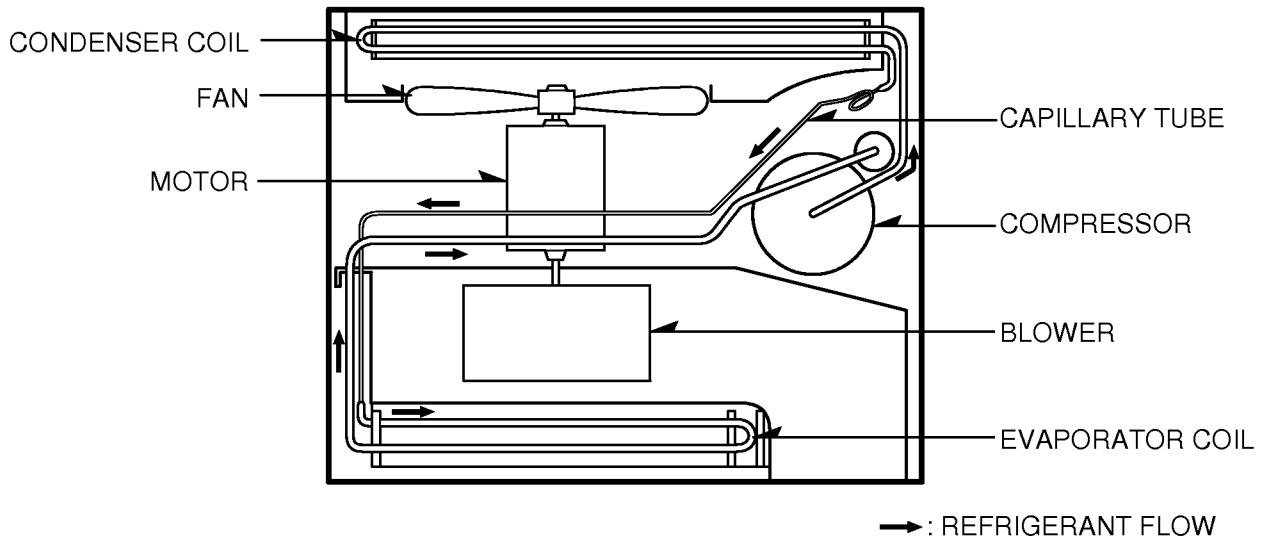

Following is a brief description of the important components and their function in what is called the refrigeration system. Reference should be made to Figure. 28 to follow the refrigeration cycle and the flow of the refrigerant in the cooling cycle.

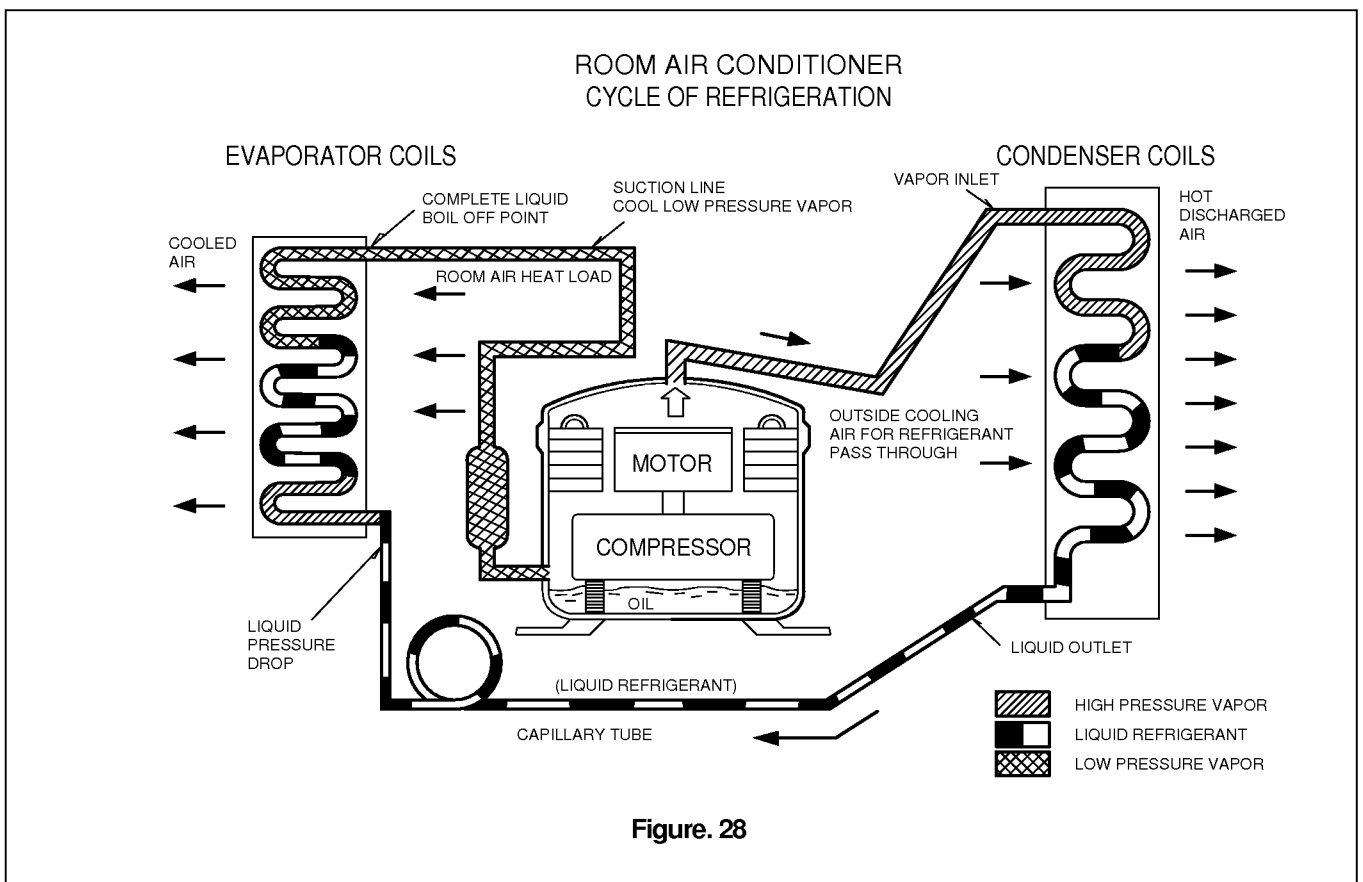

4.3 TROUBLE SHOOTING GUIDE

In general, possible trouble is classified by two causes. The one is called Starting Failure which is caused from an electrical defect, and the other is Ineffective Air Conditioning caused from a defect in the refrigeration circuit and improper application.

Unit runs but poor cooling.

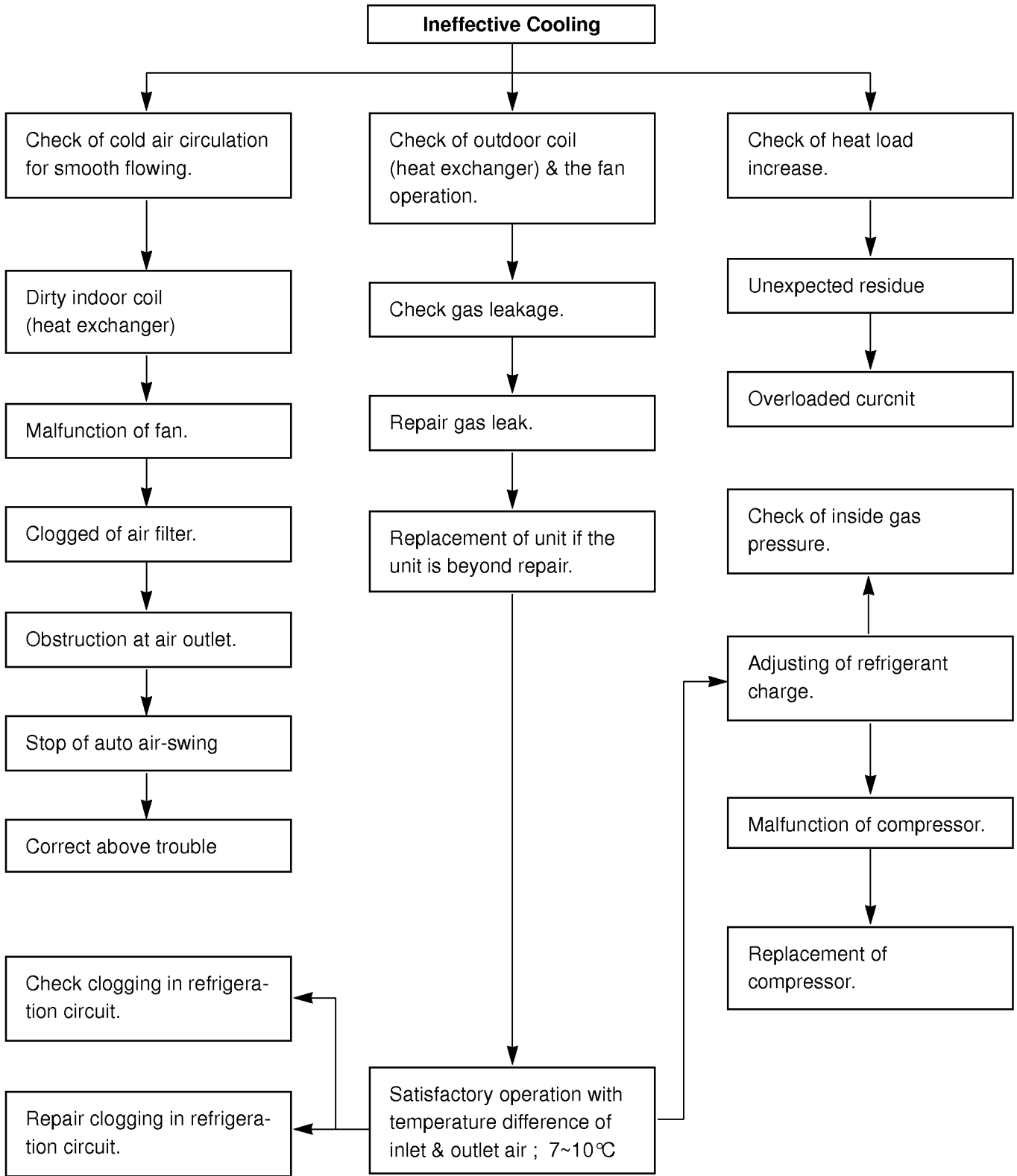

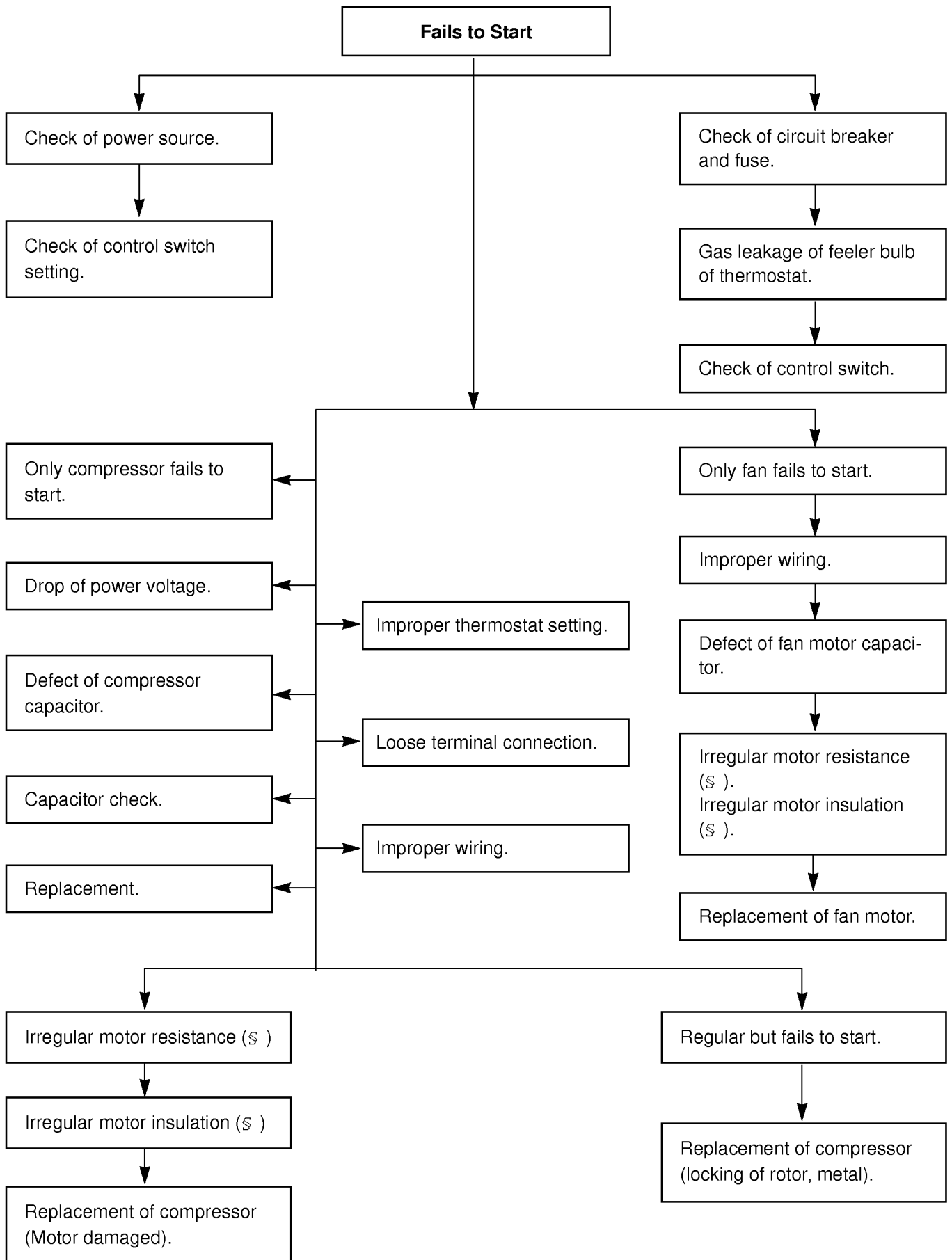

COMPLAINT	CAUSE	REMEDY
Fan motor will not run.	No power	Check voltage at outlet. Correct if none.
	Power supply cord	Check voltage to rotary switch. If none, check power supply cord. Replace cord if circuit is open.
	Rotary switch	Check switch continuity. Refer to wiring diagram for terminal identification. Replace switch if defective.
	Wire disconnected or connection loose	Connect wire. Refer to wiring diagram for terminal identification. Repair or replace loose terminal.
	Capacitor. (Discharge capacitor before testing.)	Test capacitor. Replace if not within $\pm 10\%$ of manufacturer's rating. Replace if shorted, open, or damaged.
	Will not rotate	Fan blade hitting shroud or blower wheel hitting scroll. Realign assembly. Units using slinger ring condenser fans must have $\frac{1}{4}$ to $\frac{5}{16}$ inch clearance to the base. If it is hitting the base, shim up the bottom of the fan motor with mounting screw(s). Check fan motor bearings, if motor shaft will not rotate, replace the motor.
Fan motor runs intermittently.	Revolves on overload.	Check voltage. If not within limits, call an electrician. Test capacitor. Check bearings. Does the fan blade rotate freely. If not, replace fan motor. Pay attention to any change from high speed to low speed. If the speed does not change, replace the motor.
Fan motor noise.	Grommets	Check grommets; if worn or missing, replace them.
	Fan	If cracked, out of balance, or partially missing, replace it.
	Blower	If cracked, out of balance, or partially missing, replace it.
	Loose set screw	Tighten it.
	Worn bearings	If knocking sounds continue when running or loose, replace the motor. If the motor hums or noise appears to be internal while running, replace motor.

COMPLAINT	CAUSE	REMEDY
Compressor will not run, but fan motor runs.	Voltage	Check voltage. See the limits on the preceding page. If not within limits, call an electrician.
	Wiring	Check the wire connections, if loose, repair or replace the terminal. If wires are off, refer to wiring diagram for identification, and replace. Check wire locations. If not per wiring diagram, correct.
	Rotary	Check for continuity, refer to the wiring diagram for terminal identification. Replace the switch if circuit is open.
	Thermostat	Check the position of knob. If not at the coldest setting, advance the knob to this setting and restart unit. Check continuity of the thermostat. Replace thermostat if circuit is open.
	Capacitor (Discharge capacitor before servicing.)	Check the capacitor. Replace if not within ; 10% of manufacturers rating. Replace if shorted, open or damaged.
	Compressor	Check the compressor for open circuit or ground. If open or grounded, replace the compressor.
	Overload	Check the compressor overload if externally mounted. Replace if open. (If the compressor temperature is high, remove the overload, cool it, and retest.)
Compressor cycles on overload.	Voltage	Check the voltage. See the limits on the preceding page. If not within limits, call an electrician.
	Overload	Check overload if externally mounted. Replace if open. (If the compressor temperature is high, remove the overload, cool, and retest.)
Compressor cycles on overload (Cont'd)	Fan motor	If not running, determine the cause. Replace if required.
	Condenser air flow restriction.	Remove the cabinet. Inspect the interior surface of the condenser; if restricted, clean carefully with a vacuum cleaner (do not damage fins) or brush. Clean the interior base before reassembling.
	Condenser fins (damaged).	If condenser fins are closed over a large area on the coil surface, head pressures will increase, causing the compressor to cycle. Straighten the fins or replace the coil.

COMPLAINT	CAUSE	REMEDY
	Capacitor	Test capacitor.
	Wiring	Check the terminals. If loose, repair or replace.
	Refrigerating system	Check the system for a restriction.
Insufficient cooling or heating.	Air filter	If restricted, clean or replace.
	Exhaust damper door	Close if open.
	Unit undersized	Determine if the unit is properly sized for the area to be cooled.
Excessive noise.	Blower or fan	Check the set screw, or clamp. If loose or missing, correct. If the blower or fan is hitting air guide rearrange the air handling parts.
	Copper tubing	Remove the cabinet and carefully rearrange tubing not to contact cabinet, compressor, shroud, and Barrier.
Auto air-swing fails.	Rotary switch.	Set the knob to HIGH COOL or LOW COOL while rocker switch is ON.
	Wiring	Check terminals. If loose, repair or replace.
	Synchronous motor.	Check the synchronous motor for open circuit.

5. SCHEMATIC DIAGRAM

5.1 CIRCUIT DIAGRAM

• MODEL : LW-C1211/C1011CL

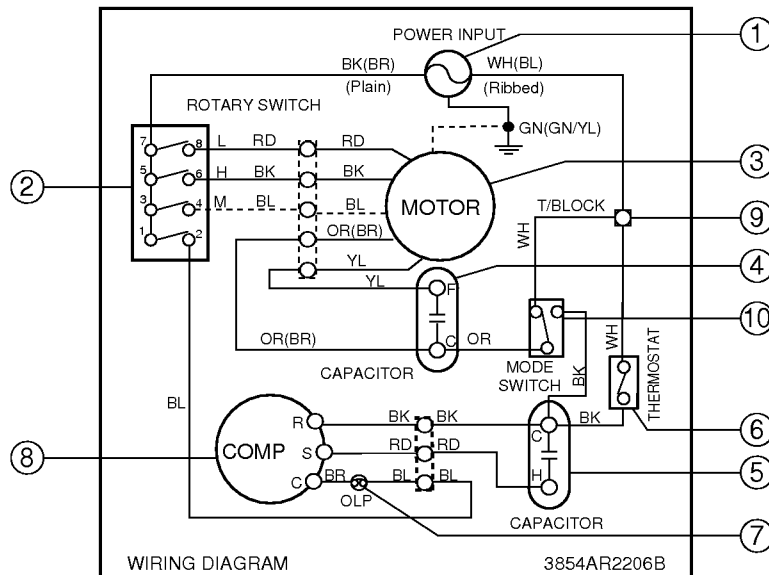

LOCATION NO.	DESCRIPTION	PART NO.		QTY PER SET	RE-MARKS
		LW-C1211CL	LW-C1011CL		
1	POWER CORD	2H01219A	2H01219B	1	
2	ROTARY SWITCH	2H00598E		1	
3	FAN MOTOR	4681AR2290A	4681AR2290B	1	
4	CAPACITOR (MOTOR)	3H00660J		1	
5	CAPACITOR (COMPRESSOR)	6120AR2194F	6120AR2194D	1	
6	THERMOSTAT	2H01109E		1	
7	OVERLOAD PROTECTOR	6750U-L029A	6750U-L031A	1	
8	COMPRESSOR	5416AR2300B	5416AR2300A	1	
9	TERMINAL BLOCK	3H00390B		1	
10	ENERGY SAVER SWITCH	2H01316A		1	

• MODEL : LW-C1010CL/C1210CL/C1030CL/C1230CL/C1260CL

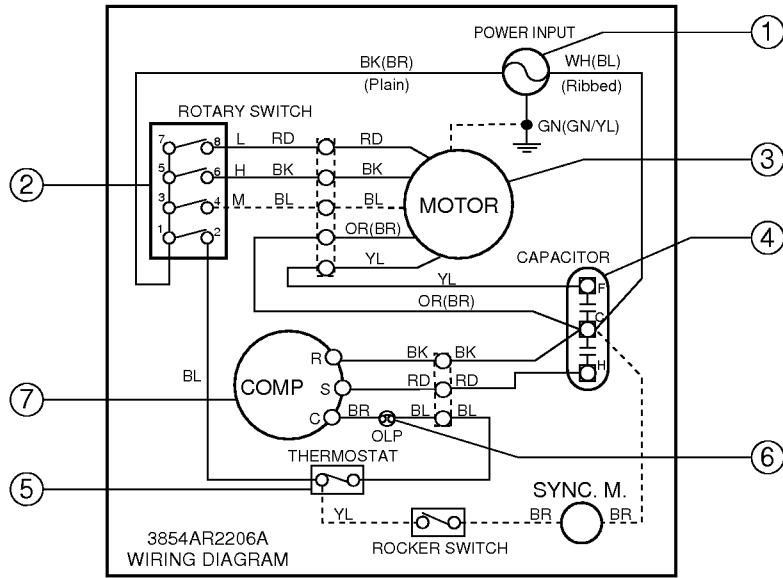

LOCATION NO.	DESCRIPTION	PART NO.					Q'TY PER SET	RE-MARKS
		LW-C1010CL	LW-C1210CL	LW-C1030CL	LW-C1230CL	LW-C1260CL		
1	POWER CORD	2H01219B	2H01219A	2H00677G	3H02255E	1		
2	ROTARY SWITCH	2H00598E					1	
3	FAN MOTOR	4681AR2290B	4681AR2290A	4681AR2290D	4681AR2290C	4681AR2290E	1	
4	CAPACITOR	6120AR2194D	6120AR2194F	6120AR2194B	6120AR2194D	1		
5	THERMOSTAT	2H01109E					1	
6	OVERLOAD PROTECTOR	6750U-L031A	6750U-L029A	6750U-L002A	6750U-L007A	6750-CL005A	1	
7	COMPRESSOR	5416AR2300A	5416AR2300B	5416AR2300D	5416AR2300C	5617AR2256C	1	

• MODEL : LW-C1031CL/C1231CL/C1261CL

LOCATION NO.	DESCRIPTION	PART NO.			QTY PER SET	RE-MARKS
		LW-C1031CL	LW-C1231CL	LW-C1261CL		
1	POWER CORD	2H00677G		3H02255E	1	
2	FAN MOTOR	4681AR2290D	4681AR2290C	4681AR2290E	1	
3	CAPACITOR	6120AR2194B		6120AR2194D	1	
4	COMPRESSOR	5416AR2300D	5416AR2300C	5417AR2256C	1	
5	OVERLOAD PPROTECTOR	6750U-L002A	6750U-L007A	6750-CL005A	1	
6	MAIN PWB ASM	6871AQ2184B			1	
7	TRANSFORMER ASM	6171AQ3075A			1	
8	DISPLAY PWB ASM	6871AQ3073B			1	
9	THERMISTOR ASM	3Q35027D			1	
10	CONNECTOR	6630AQ9069L			1	
11	FUSE	6900AQ9028A			1	

Exploded View & Replacement Parts List

Exploded View LW-C1012CM.WYCRM

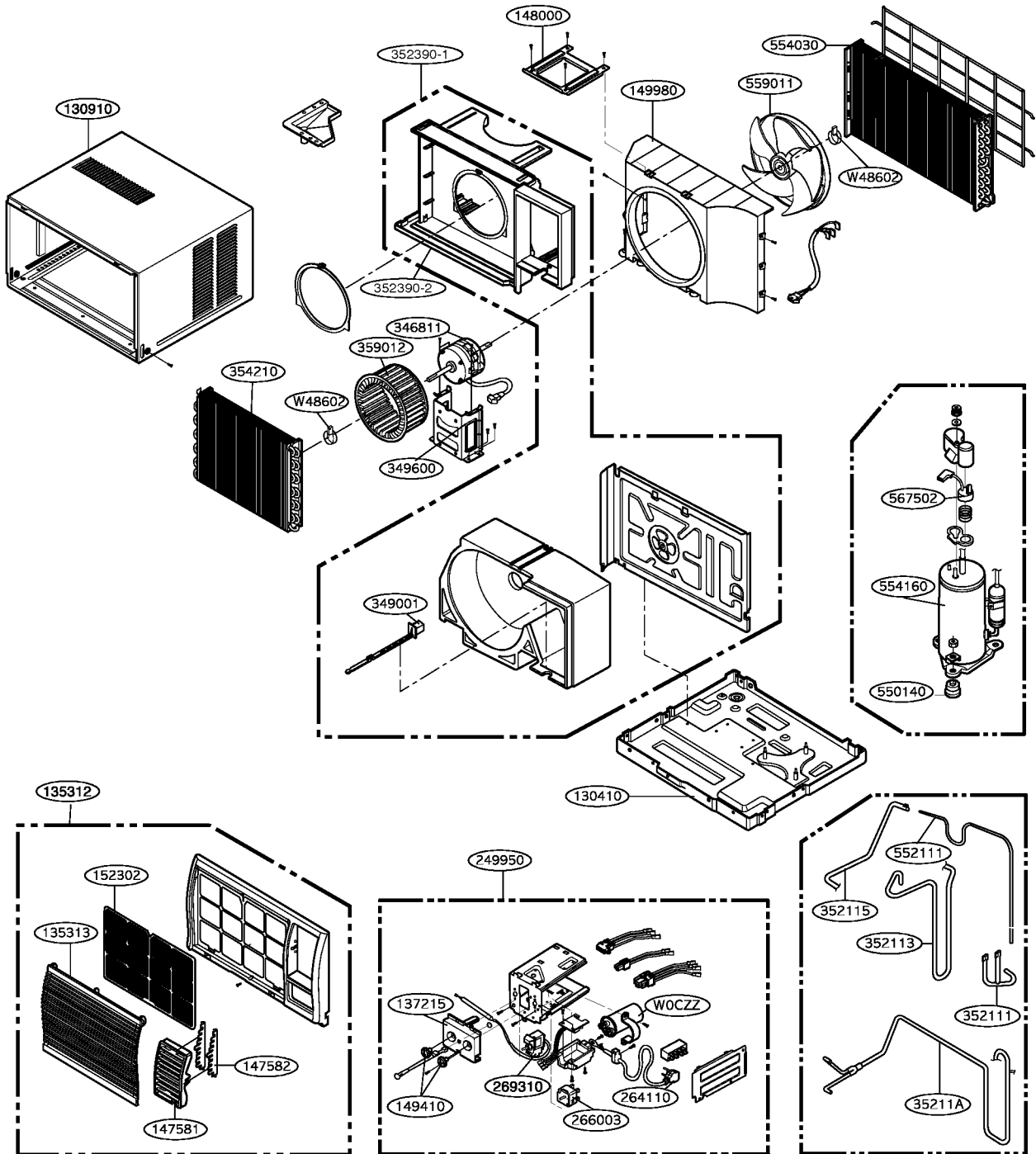

Parts List

LOCATION NO	PART NO	DESCRIPTION	REMARKS
130410	3041AR2291C	BASE ASSY,SINGLE	R
130910	3091AR2286C	CABINET ASSY,SINGLE	R
135312	3531AR2523K	GRILLE ASSY,FRONT(SINGLE)	R
135313	3530AR1156A	GRILLE,NLET	R
137215	3720AR2208A	PANEL,CONTROL	R
147581	4758AR2196A	LOUVER,HORIZONTAL	R
147582	4758AR3307A	LOUVER,VERTICAL	R
148000	4800AR3306A	BRACE	R
149410	4941AR3705A	KNOB ASSY	R
149980	4998AR1110A	SHROUD	R
152302	5231AR1152A	FILTER(MECH),A/C	R
238310	3831AR1191B	ESCUTCHEON	R
249950	4995AR2292C	CONTROL BOX ASSY,SINGLE	R
264110	2H01219B	POWER CORD ASSY	R
266003	2H00598E	SWITCH,ROTARY	R
269310	2H01109H	THERMOSTAT ASSY	R
346811	4681AR2975B	MOTOR ASSY,AC	R
349001	4900AR3706A	DAMPER,VENTILATION	R
349600	4960AR2214A	MOUNT,MOTOR	R
352111	5211AR3358A	TUBE ASSY,FORMED COND	R
352113	5210AR2258B	TUBE,DISCHARGE	R
352115	5210AR2277A	TUBE,EVAPORATOR	R
35211A	5211AR2322B	TUBE ASSY,SUCTION SINGLE	R
352390-2	5239AR2297A	AIR GUIDE ASSY	R
352390-1	5239AR3428A	AIR GUIDE ASSY	R
354210	5421AR2301A	EVAPORATOR ASSY	R
359012	5834AR1174A	FAN ASSY,BLOWER	R
550140	4H00982C	ISOLATOR,COMP	R
552111	5425AR3414A	TUBE ASSY,CAPILLARY	R
554030	5403AR2302B	CONDENSER ASSY	R
554160	5416AR2300A	COMPRESSOR	R
559011	5900AR1173A	FAN ASSY,AXIAL	R
567502	6750U-L031A	O.L.P	R
W0CZZ	6120AR2194D	CAPACITOR	R
W48602	3H02932B	CLAMP,SPRING	R