

# Service Manual

Room Air Conditioner

**CW-XC100HU**

**CW-XC120HU**

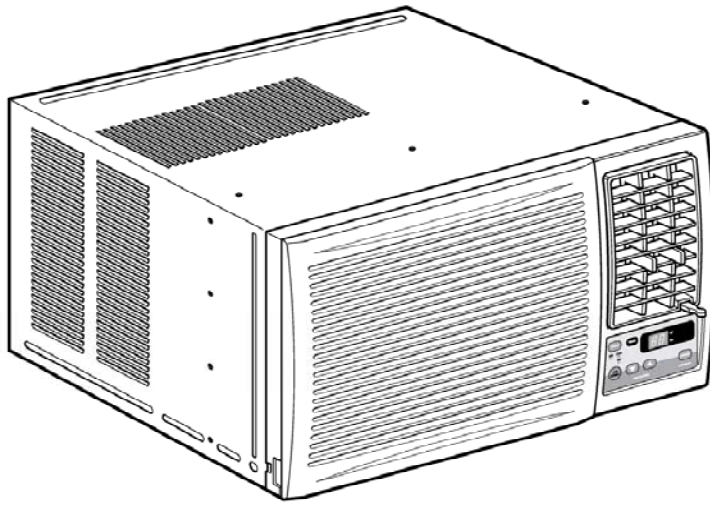

**⚠ WARNING**

This service information is designed for experienced repair technicians only and is not designed for use by the general public. It does not contain warnings or cautions to advise non-technical individuals of potential dangers in attempting to service a product. Products powered by electricity should be serviced or repaired only by experienced professional technicians. Any attempt to service or repair the product or products deal with in this service information by anyone else could result in serious injury or death.

**Panasonic<sup>®</sup>**

© 2004 Matsushita Electric Industrial co., Ltd.  
All rights reserved. Unauthorized copying and  
distribution is violation of law.

# CONTENTS

## 1. PREFACE

1.1 SAFETY PRECAUTIONS.....	2
1.2 SPECIFICATIONS.....	3
1.3 ABOUT THE CONTROLS ON THE AIR CONDITIONER.....	4

## 2. DISASSEMBLY INSTRUCTIONS

2.1 MECHANICAL PARTS .....	6
2.1.1 FRONT GRILLE .....	6
2.1.2 CABINET .....	6
2.1.3 CONTROL BOX .....	6
2.2 AIR HANDLING PARTS .....	7
2.2.1 AIR GUIDE AND BLOWER .....	7
2.2.2 FAN AND SHROUD .....	7
2.3 ELECTRICAL PARTS.....	8
2.3.1 OVERLOAD PROTECTOR .....	8
2.3.2 COMPRESSOR.....	8
2.3.3 CAPACITOR.....	8
2.3.4 POWER CORD .....	9
2.3.5 THERMISTOR.....	9
2.3.6 THERMOSTAT .....	9
2.3.7 MOTOR.....	9
2.4 REFRIGERATION CYCLE .....	10
2.4.1 CONDENSER.....	10
2.4.2 EVAPORATOR.....	10
2.4.3 CAPILLARY TUBE .....	11

## 3. INSTALLATION

3.1 SELECT THE BEST LOCATION.....	13
3.2 CHECK OF INSTALLATION.....	13
3.3 HOW TO DRAIN.....	13
3.4 HOW TO INSTALL .....	14
3.4.1 WHEN USING GASKET.....	14
3.4.2 WHEN USING INSTALLATION KITS...	14

## 4. TROUBLESHOOTING GUIDE

4.1 OUTSIDE DIMENSIONS .....	18
4.2 PIPING SYSTEM.....	18
4.3 TROUBLESHOOTING GUIDE .....	19

## 5. SCHEMATIC DIAGRAM

5.1 CIRCUIT DIAGRAM .....	27
5.2 ELECTRONIC CONTROL DEVICE.....	28
5.3 COMPONENTS LOCATION(FOR MAIN P.C.B ASM) ...	29
5.4 COMPONENTS LOCATION(FOR DISPLAY P.C.B ASM) ...	29

## 6. EXPLODED VIEW .....

## 7. REPLACEMENT PARTS LIST .....

## 1. PREFACE

This SERVICE MANUAL provides various service information, including the mechanical and electrical parts etc. This room air conditioner was manufactured and assembled under a strict quality control system. The refrigerant is charged at the factory. Be sure to read the safety precautions prior to servicing the unit.

### 1.1 SAFETY PRECAUTIONS

1. When servicing the unit, set the POWER SWITCH to OFF and unplug the power cord.
2. Observe the original lead dress.  
If a short circuit is found, replace all parts which have been overheated or damaged by the short circuit.

## 1.2 SPECIFICATIONS

ITEMS		MODELS	CW-XC100HU	CW-XC120HU
POWER SUPPLY	Ø, V, Hz		1, 115, 60	
COOLING CAPACITY	Btu/h.		9,750	11,800
POWER INPUT	W		900	1,090
RUNNING CURRENT	A		8.3	10.0
EER	Btu/h.W		10.8	10.8
OPERATING CONDITION	INDOOR	°F(°C)	DB : 80(26.7) WB : 67(19.4)	
	OUTDOOR	°F(°C)	DB : 95(35) WB : 75(23.9)	
REFREIGERANT (R-22) CHARGE			490g(17.3 oz)	500g(17.6 oz)
EVAPORATOR			2 ROW 16 STACKS,SLIT-FIN TYPE	2 ROW 13 STACKS,SLIT-FIN TYPE
CONDENSER			2 ROW 18 STACKS,LOUVERED-FIN TYPE	2 ROW 17 STACKS,LOUVERED-FIN TYPE
FAN	INDOOR		TURBO FAN	
	OUTDOOR		PROPELLER TYPE FAN WITH SLINGER-RING	
FAN SPEED	FAN/COOLING		3/3	
FAN MOTOR			6 POLES	
OPERATION CONTROL			REMOTE CONTROLLER	
ROOM TEMP. CONTROL			THERMISTOR	
AIR DIRECTION CONTROL	VERTICAL		MANUAL	
	HORIZONTAL		MANUAL	
CONSTRUCTION			SLIDE IN-OUT CHASSIS	
PROTECTOR	COMPRESSOR		OVERLOAD PROTECTOR	
	FAN MOTOR		INTERNAL THERMAL PROTECTOR	
POWER CORD			3 WIRE WITH GROUNDING	
			ATTACHMENT PLUG (CORD-CONNECTED TYPE)	
DRAIN SYSTEM			DRAIN PIPE OR SPLASHED BY FAN SLINGER	
NET WEIGHT	lbs(kg)		95(43)	100(45)
DIMENSION(W*H*D)	inch(mm)		23 5/8*14 31/32*22 5/16 (600*380*567)	

\* DB: Dry Bulb

\*\* WB: Wet Bulb

✱ The specifications will be changed without notice for further improvement.

## 1.3 ABOUT THE CONTROLS ON THE AIR CONDITIONER

### • VENTILATION

The ventilation lever must be in the CLOSE position in order to maintain the best cooling conditions. When fresh air is necessary in the room, set the ventilation lever to the OPEN position. The damper is opened and room air is drawn out.

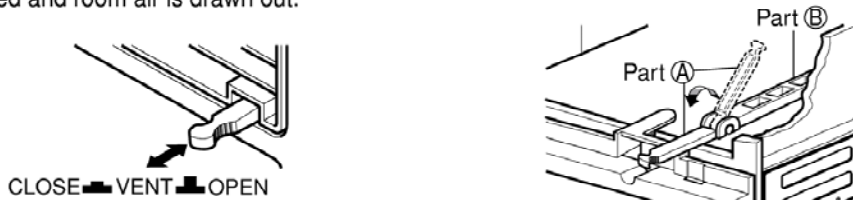

**NOTE:** Before using the ventilation feature, and prior to installing the front grille, pull down part (A) until level with part (B).

### • CONTROL LOCATIONS

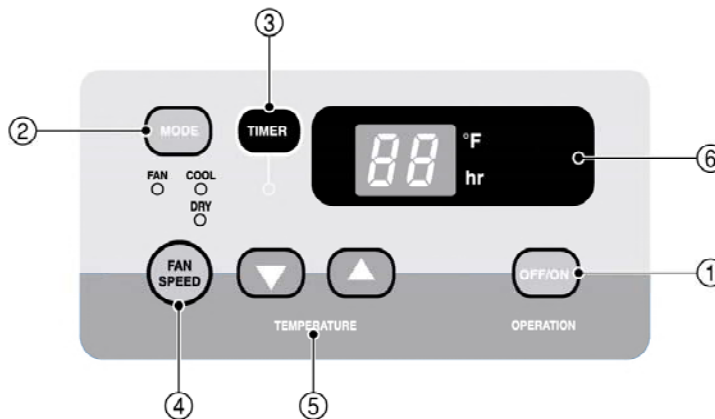

#### ① OPERATION

- To turn the air conditioner ON, push the OFF/ON button.
- To turn the air conditioner OFF, push the button again.
- This button takes priority over any other buttons.
- When you first turn it on, the air conditioner is on the High cool mode and the temp. at 72°F (22°C).

#### ② MODE

- Every time you push this button, it will toggle between COOL, FAN and DRY.

#### ③ ON/OFF TIMER

- Every time you push the TIMER button, timer is set as follows. (1Hour → 2Hours → 3Hours → 4Hours → 5Hours → 6Hours → 7Hours → 8Hours → 9Hours → 10Hours → 11Hours → 12Hours → 0)
- The Setting Temperature will be raised by 2°F (1°C) 30 min. later and by 2°F (1°C) after another 30 min.

#### ④ FAN SPEED

- Every time you push this button it is set as follows. {High(F3) → Low(F1) → Med(F2) → High(F3)...}.

#### ⑤ TEMPERATURE SETTING

- This button can automatically control the temperature of the room. The temperature can be set within a range of 60°F to 86°F by 1°F (16°C to 30°C by 1°C). Select the lower number for lower temperature of the room.

#### ⑥ REMOTE CONTROL SIGNAL RECEIVER

#### ⑦ DRY

- When this unit is in dry mode, the fan rotates in low speed. The fan stops when the compressor stops cooling. Approximately every 3 minutes the fan will turn on and the unit checks the room air temperature to set itself.

## • REMOTE CONTROL

**Precaution:** The Remote Controller will not function properly if strong light strikes the sensor window of the air conditioner or if there are obstacles between the Remote Controller and the air conditioner.

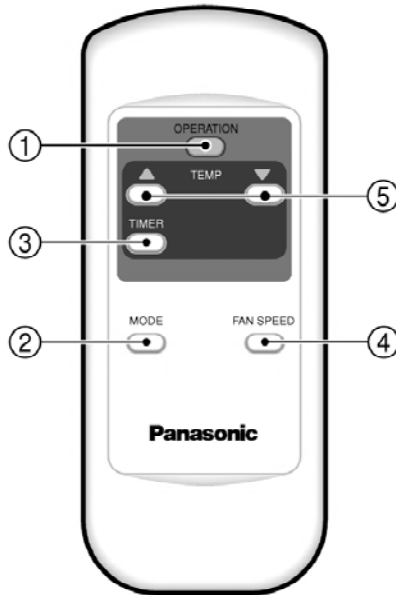

### ① OPERATION

- To turn the air conditioner ON, push the button.
- To turn the air conditioner OFF, push the button again.
- This button takes priority over any other buttons.
- When you first turn it on, the air conditioner is on the High cool mode and the temp. at 72°F(22°C).

### ② MODE

- Every time you push this button, it will toggle between COOL, FAN and DRY.

### ③ ON/OFF TIMER

- STOPPING OPERATION
- Every time you push this button, when the air conditioner is operating, timer is set as follows. (1Hour → 2Hours → 3Hours → 4Hours → 5Hours → 6Hours → 7Hours → 8Hours → 9Hours → 10Hours → 11Hours → 12Hours → 0).
- The Setting Temperature will be raised by 2°F (1°C) 30 min. later and by 2°F (1°C) after another 30 min.

### - STARTING OPERATION

- Every time you push this button, when the air conditioner is not operating, timer is set as follows. (1Hour → 2Hours → 3Hours → 4Hours → 5Hours → 6Hours → 7Hours → 8Hours → 9Hours → 10Hours → 11Hours → 12Hours → 0)

### ④ FAN SPEED

- Every time you push this button it is set as follows. {High(F3) → Low(F1) → Med(F2) → High(F3)...}.

### ⑤ TEMPERATURE SETTING

- This button can automatically control the temperature of the room.
- The temperature can be set within a range of 60°F to 86°F by 1°F(16°C to 30°C by 1°C). Select the lower number for lower temperature of the room.

## 2. DISASSEMBLY INSTRUCTIONS

— Before the following disassembly, POWER SWITCH set to OFF and disconnect the power cord.

### 2.1 MECHANICAL PARTS

#### 2.1.1 FRONT GRILLE

1. Open the Inlet grille upward .
2. Remove the screw which fastens the front grille.
3. Pull the front grille from the right side.
4. Remove the front grille.
5. Re-install the component by referring to the removal procedure, above.(See Figure 1)

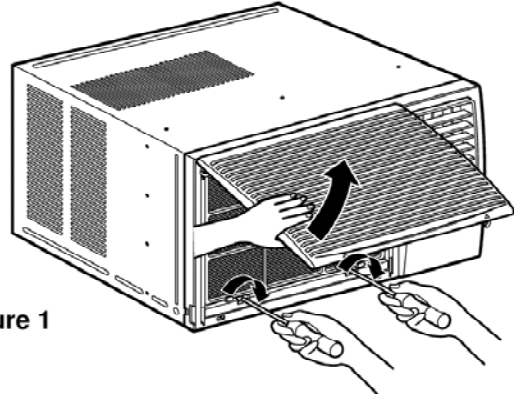

Figure 1

#### 2.1.2 CABINET

1. After disassembling the FRONT GRILLE, remove the 2 screws which fasten the cabinet at both sides.
2. Remove the 2 screws which fasten the cabinet at back.
3. Pull the base pan forward. (See Figure 2)
4. Remove the cabinet.
5. Re-install the component by referring to the removal procedure, above.

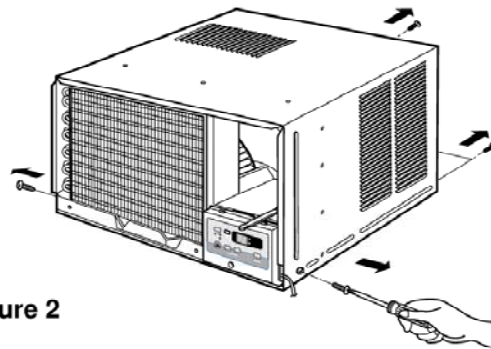

Figure 2

#### 2.1.3 CONTROL BOX

1. Remove the front grille. (Refer to section 2.1.1)
2. Remove the cabinet. (Refer to section 2.1.2)
3. Remove the 2 screws which fasten the control box cover.
4. Remove two housings which connect compressor wire and motor wire in the control box.
5. Discharge the capacitor by placing a 20,000 ohm resistor across the capacitor terminals.
6. Remove the 2 screws which fasten the control box.
7. Pull the control box forward completely.
8. Re-install the components by referring to the removal procedure, above. (See Figure 3)  
(Refer to the circuit diagram found on pages 27 in this manual and on the control box.)

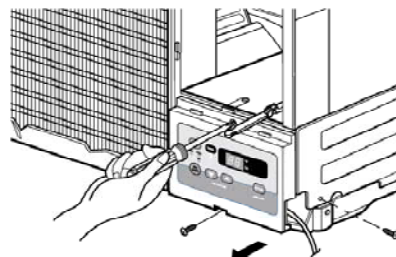

Figure 3

## 2.2 AIR HANDLING PARTS

### 2.2.1 AIR GUIDE AND BLOWER

1. Remove the front grille. (Refer to section 2.1.1)
2. Remove the cabinet. (Refer to section 2.1.2)
3. Remove the control box. (Refer to section 2.1.3)
4. Remove the 4 screws which fasten the brace.
5. Remove the brace.
6. Remove the 2 screws which fasten the evaporator.
7. Move the evaporator forward and pulling it upward slightly. (See Figure 4)
8. Move the evaporator to the left carefully.
9. Pull out the hook of orifice by pushing the tabs and remove it. (See Figure 5)
10. Remove the clamp with a hand pliers which secures the blower.
11. Remove the blower.
12. Remove the 4 screws which fasten the air guide from the barrier.
13. Move the air guide backward, pulling out from the base pan.
14. Re-install the components by referring to the removal procedure, above.

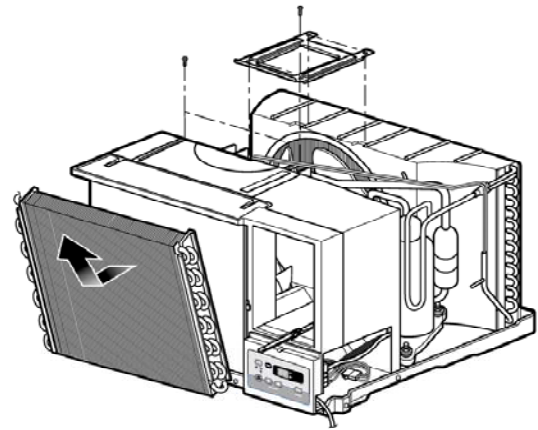

Figure 4

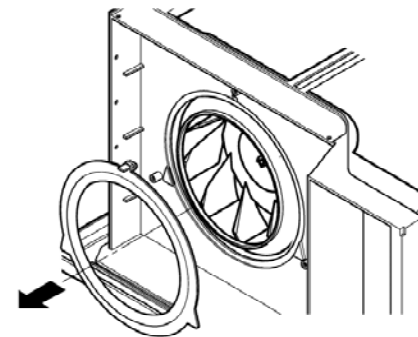

Figure 5

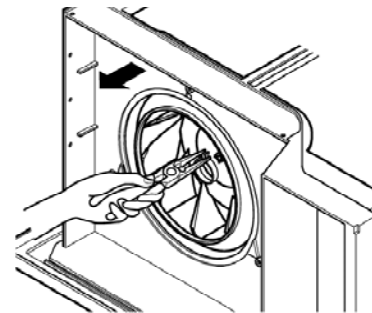

Figure 6

### 2.2.2 FAN

1. Remove the cabinet. (Refer to section 2.1.2)
2. Remove the brace (Refer to section 2.2.1)
3. Remove the 4 screws which fasten the condenser.
4. Move the condenser to the left carefully.
5. Remove the clamp which secures the fan.
6. Remove the fan. (See Figure 7)
7. Re-install by referring to the removal procedure.

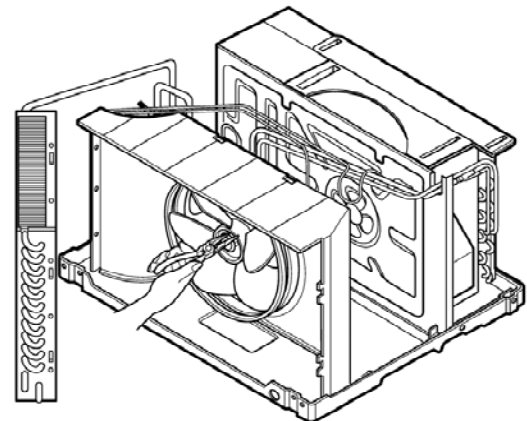

Figure 7

### 2.2.3 SHROUD

1. Remove the fan. (Refer to section 2.2.2)
2. Remove the screw which fastens the shroud.
3. Remove the shroud. (See Figure 8)
4. Re-install the component by referring to the removal procedure, above.

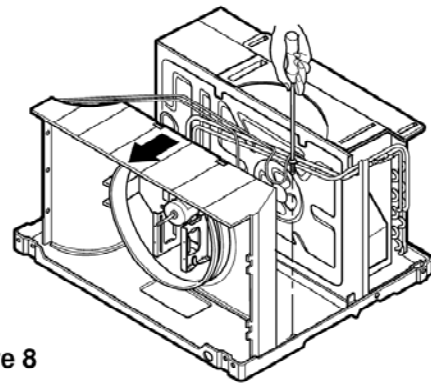

Figure 8

## 2.3 ELECTRICAL PARTS

### 2.3.1 OVERLOAD PROTECTOR

1. Remove the cabinet. (Refer to section 2.1.2)
2. Remove the nut which fastens the terminal cover.
3. Remove the terminal cover. (See Figure 9)
4. Remove all the leads from the overload protector.
5. Remove the overload protector.
6. Re-install the component by referring to the removal procedure, above.

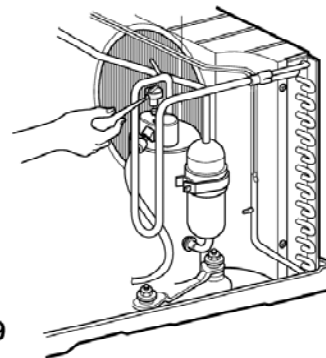

Figure 9

### 2.3.2 COMPRESSOR

1. Remove the cabinet. (Refer to section 2.1.2)
2. Discharge the refrigerant system using a Freon™ Recovery System.  
If there is no valve to attach the recovery system, install one (such as a WATCO A-1) before venting the Freon™. Leave the valve in place after servicing the system.
3. Remove the overload protector. (Refer to section 2.3.1)
4. After purging the unit completely, unbraid the suction and discharge tubes at the compressor connections.
5. Remove the 3 nuts and the 3 washers which fasten the compressor.
6. Remove the compressor. (See Figure 10)
7. Re-install the components by referring to the removal procedure, above.

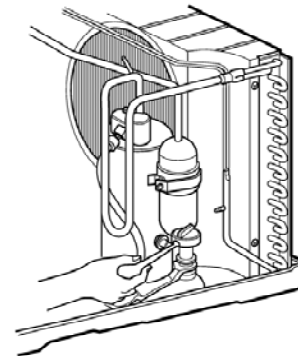

Figure 10

### 2.3.3 CAPACITOR

1. Remove the control box. (Refer to section 2.1.3)
2. Remove the screw which fasten control panel from control box.
3. Remove the screw which located in the front.
4. Open the bottom side of control box.
5. Remove the screw and the clamp which fastens the capacitor.
6. Disconnect all the leads of capacitor terminals.
7. Re-install the components by referring to the removal procedure, above. (See Figure 11)

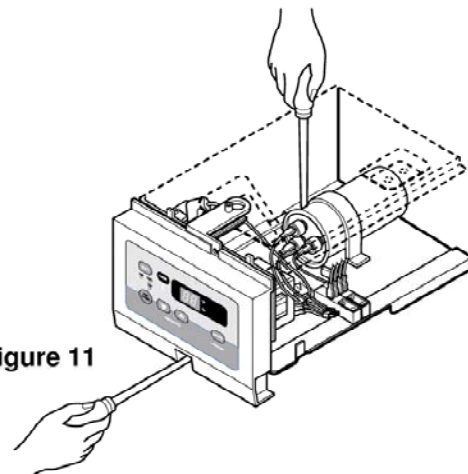

Figure 11



### 2.3.4 POWER CORD

1. Remove the control box. (Refer to section 2.1.3)
2. Open the control box. (Refer to section 2.3.3)
3. Disconnect the grounding screw from the control box.
4. Disconnect the 2 receptacles.
5. Remove a screw which fastens the clip cord.  
(See Figure 12)
6. Remove the power cord.
7. Re-install the component by referring to the above removal procedure, above.  
(Use only one ground-marked hole  $\oplus$  for ground connection.)
8. If the supply cord of this appliance is damaged, it must be replaced by the special cord. (The special cord means the cord which has the same specification marked on the supply cord attached at the unit.)

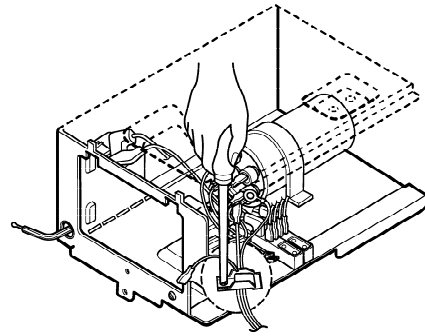

Figure 12

### 2.3.5 THERMISTOR

1. Remove the control box. (Refer to section 2.1.3)
2. Open the control box. (Refer to section 2.3.3)
3. Disconnect the thermistor terminals from main P.C.B assembly.
4. Remove the thermistor.
5. Re-install the components by referring to the above removal procedure. (See Figure 13)

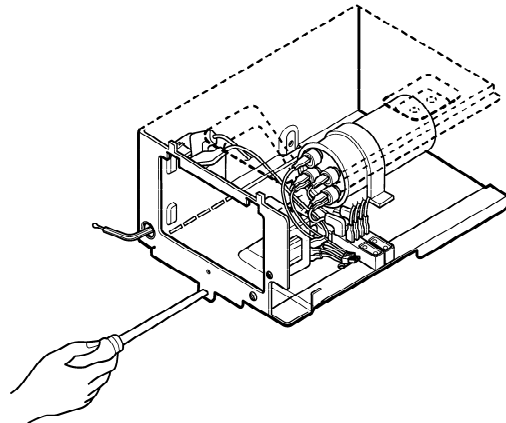

Figure 13

### 2.3.6 MOTOR

1. Remove the cabinet. (Refer to section 2.1.2)
2. Remove the evaporator. (Refer to section 2.2.1)
3. Remove the orifice. (Refer to section 2.2.1)
4. Remove the blower. (Refer to section 2.2.1)
5. Remove the fan. (Refer to section 2.2.2)
6. Remove the control box cover and disconnect 5 or 4 wires of motor housing. (Refer to section 2.1.3)
7. Remove the 2 or 4 screws which fasten the motor from the mount motor. (See Figure 13)
8. Remove the motor.
9. Re-install the components by referring to the removal procedure, above.(See Figure 13)

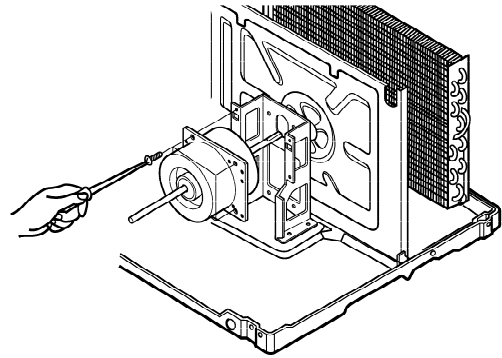

Figure 13

#### CAUTION

Discharge the refrigerant system using a Freon™ Recovery System. If there is no valve to attach the recovery system, install one (such as a WATCO A-1) before venting the Freon™. Leave the valve in place after servicing the system.

### 2.4.1 CONDENSER

1. Remove the cabinet. (Refer to section 2.1.2)
2. Remove the 4 screws which fasten the brace.(Refer to section 2.2.1)
3. Remove the 5 screws which fasten the condenser and shroud.
4. After discharging the refrigerant completely, unbrazed the interconnecting tube at the condenser connections.
5. Remove the condenser.
6. Re-install the component by referring to notes. (See Figure 14)

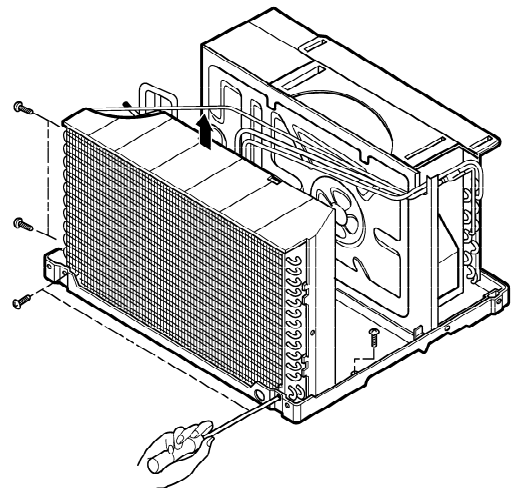

Figure 14

### 2.4.2 EVAPORATOR

1. Remove the cabinet. (Refer to section 2.1.2)
2. Remove the 2 screws which fasten the evaporator.
3. Move the evaporator sideways carefully. (Refer to section 2.2.1)
4. After discharging the refrigerant completely, unbrazed the interconnecting tube at the evaporator connections.
5. Remove the evaporator.
6. Re-install the component by referring to notes. (See Figure 15)

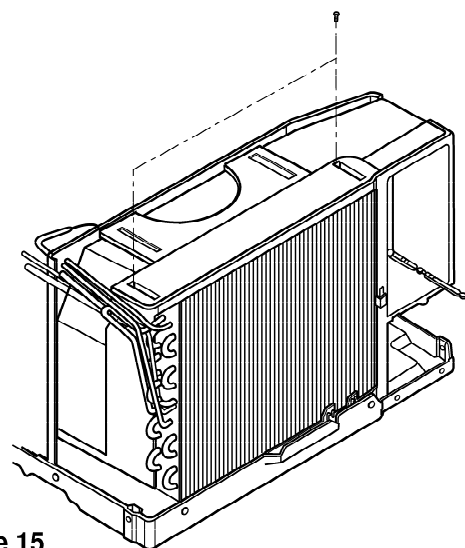

Figure 15

### 2.4.3 CAPILLARY TUBE

1. Remove the cabinet. (Refer to section 2.1.2)
2. After discharging the refrigerant completely, unbrazed the interconnecting tube at the capillary tube. (See caution above)

3. Remove the capillary tube.
4. Re-install the component by referring to notes.

#### NOTES

— Replacement of the refrigeration cycle.

1. When replacing the refrigeration cycle, be sure to discharge the refrigerant system using a Freon™ recovery System.  
If there is no valve to attach the recovery system, install one (such as a WATCO A-1) before venting the Freon™. Leave the valve in place after servicing the system.
2. After discharging the refrigerant from unit completely, remove the desired component, and unbrazed the pinch-off tubes.
3. Braze service valves into the pinch-off tube ports, leaving the valves open.
4. Braze the pinch-off tubes with Service valves.
5. Evacuate as follows.
  - 1) Connect the vacuum pump, as illustrated figure 16A.
  - 2) Start the vacuum pump, slowly open manifold valves A and B with two full turns counterclockwise and leave the valves open. The vacuum pump is now pulling through valves A and B up to valve C (figure 17B) by means of the manifold and entire system.

#### CAUTION

If high vacuum equipment is used, just slightly loosen the valves A and B for a few minutes, then open slowly with the two full turns counterclockwise. This will keep oil from foaming and being drawn into the vacuum pump.

- 3) Operate the vacuum pump for 20 to 30 minutes, until 600 microns of vacuum is obtained. Close valves A and B, and observe vacuum gauge for a few minutes. A rise in pressure would indicate a possible leak or moisture remaining in the system. With valves A and B closed, stop the vacuum pump.
- 4) Remove the hose from the vacuum pump and place it on the charging cylinder. See figure 16B.  
Open valve C.  
Discharge the line at the manifold connection.
- 5) The system is now ready for final charging.

6. Recharge as follows :

- 1) Refrigeration cycle systems are charged from the High-side. If the total charge cannot be put in the High-side, the balance will be put in the suction line through the access valve which you installed as the system was opened.
- 2) Connect the charging cylinder as shown in figure 16B.  
With valve C open, discharge the hose at the manifold connection.
- 3) Open valve A and allow the proper charge to enter the system. Valve B is still closed.
- 4) If more charge is required, the high-side will not take it. Close valve A.
- 5) With the unit running, open valve B and add the balance of the charge.
  - a. Do not add the liquid refrigerant to the Low-side.
  - b. Watch the Low-side gauge; allow pressure to rise to 30lbs (0.2MP).
  - c. Turn off valve B and allow pressure to drop.
  - d. Repeat steps b. and c. until the balance of the charge is in the system.
- 6) When satisfied the unit is operating correctly, use the pinch-off tool with the unit still running and clamp on to the pinch-off tube. Using a tube cutter, cut the pinch-off tube about 2 inches from the pinch-off tool. Use sil-fos brazing rod and braze pinch-off tube closed. Turn off the unit, allow it to set for a while, and then test the leakage of the pinch-off connection.

**Equipment needed:** Vacuum pump, Charging cylinder, Manifold gauge, Brazing equipment. Pin-off tool capable of making a vapor-proof seal, Leak detector, Tubing cutter, Hand Tools to remove components, Service valve.

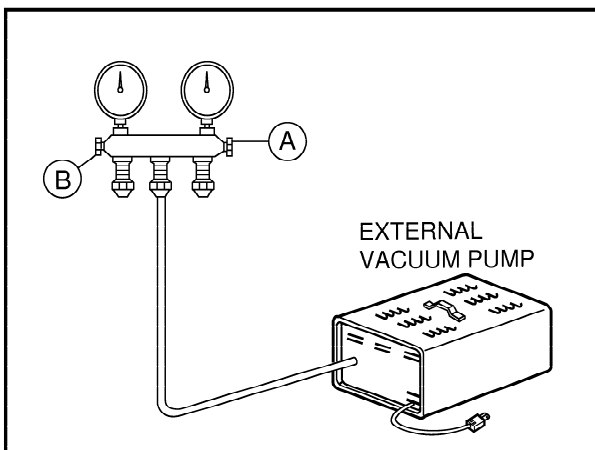
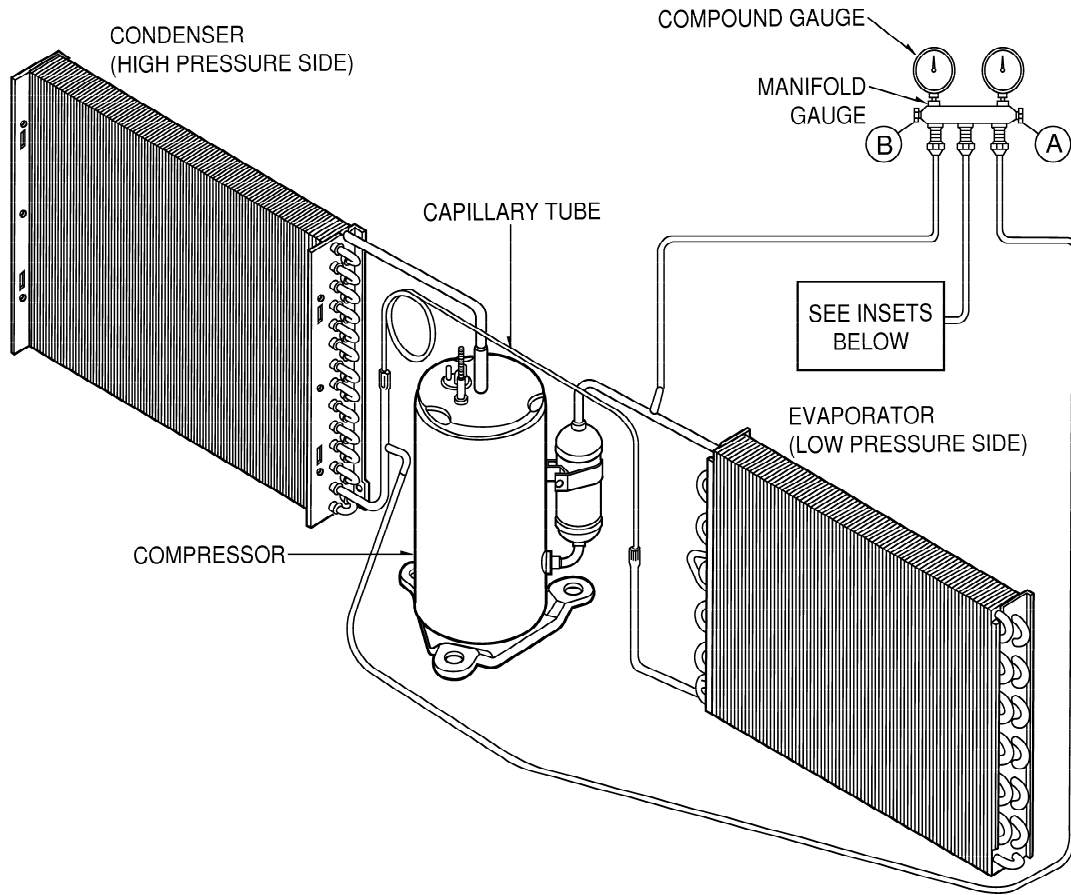

**Figure 16A-Pulling Vacuum**

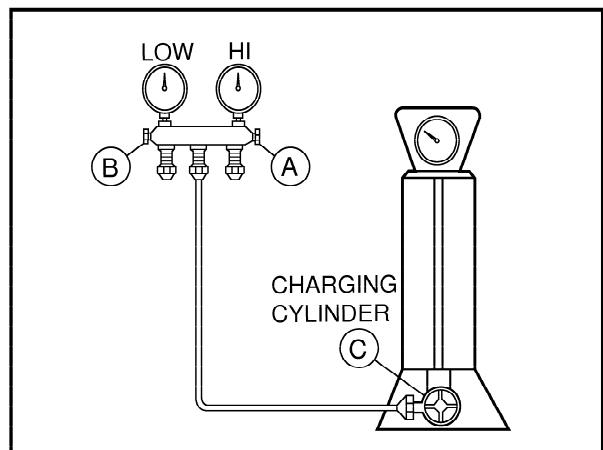

**Figure 16B-Charging**

## 3. INSTALLATION

### 3.1 SELECT THE BEST LOCATION

1. To prevent vibration and noise, make sure the unit is installed securely and firmly.
2. Install the unit where the sunlight does not shine directly on the unit.
3. The outside of the cabinet must extend outward for at least 30.48cm(12") and there should be no obstacles, such as a fence or wall, within 50.8cm(20") from the back of the cabinet because it will prevent heat radiation of the condenser. Restriction of outside air will greatly reduce the cooling efficiency of the air conditioner.

#### CAUTION

All side louvers of the cabinet must remain exposed to the outside of the structure.

4. Install the unit a little slanted so the back is slightly lower than the front (about 12.7mm(1/2")). This will help force con-densed water to the outside.
5. Install the unit from the bottom about 76.2cm(30")~152.4cm(60") above the floor level.

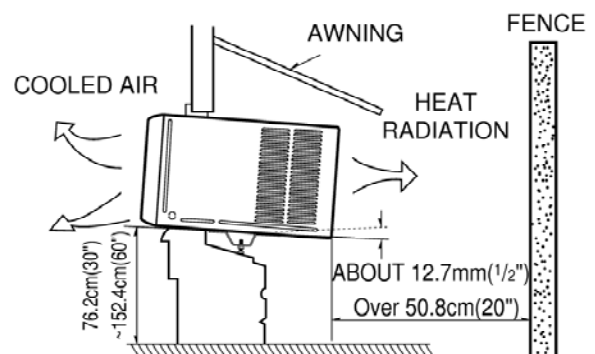

Figure 17

### 3.2 CHECK OF INSTALLATION

The setting conditions must be checked prior to initial starting.

The undermentioned items are especially important checking points when the installation is finished.

1. Grounding wire (Green or Green and Yellow) is provided in the power cord. The green wire must be grounded.
2. Connect to a single-outlet 15A circuit.
3. To avoid vibration or noise, make sure the air conditioner is installed securely.
4. Avoid placing furniture or draperies in front of the air inlet and outlet.

### 3.3. HOW TO SECURE THE DRAIN PIPE (When using drain pipe)

In humid weather, excess water may cause the BASE PAN to overflow. To drain the water, remove the DRAIN CAP and secure the DRAIN PIPE to the rear hole of the BASE PAN. Press the drain pipe into the hole by pushing down and away from the fins to avoid injury. (See Fig.1)

#### Optional (CW3H02502B)

1. Remove the rubber plug and slide the chassis out from the cabinet. (See Fig. 2)
2. Install the drain pan over the corner of the cabinet where you removed the plug with 4 (or 2) screws. (See Fig.3)
3. Connect the drain hose to the outlet located at the bottom of the drain pan. You can purchase the drain hose or tubing locally to satisfy your particular needs. (Drain hose is not supplied). (See Fig.3)
4. Select the most appropriate connection from among the figures to the right (by considering the hole of the unit) to fit drain pan to your own unit. (See Fig.3)
5. Slide the chassis back into the cabinet. Reinstall the cabinet screws. Secure the cabinet to chassis by using screws. (See Fig.4)

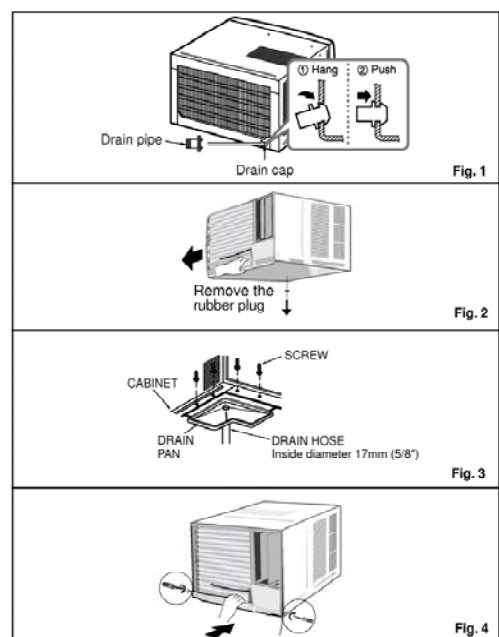

### 3.4 HOW TO INSTALL

#### 3.4.1 WHEN USING GASKET

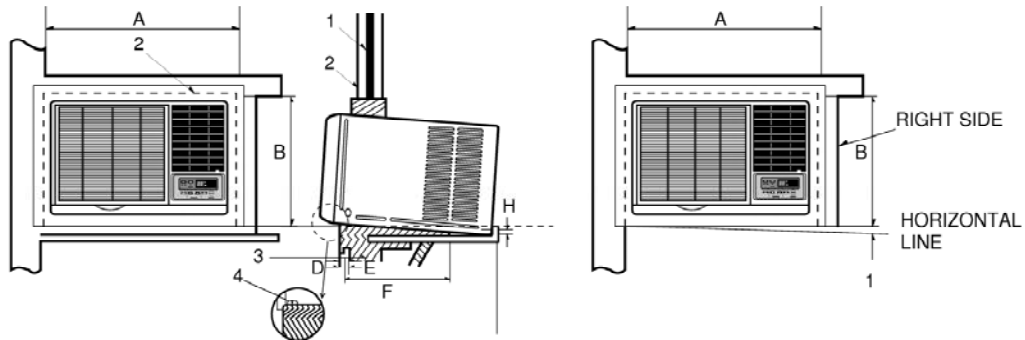

- 1. WINDOW (WIDTH-A, HEIGHT-B)
- 2. GASKET
- 3. WALL

- 4. DETAILS 5.1 x 30 ROUND HEAD WOOD SCREWS

A	B	C	D	E	F	H	I
625mm (24 <sup>5</sup> / <sub>8</sub> " )	392mm (15 <sup>7</sup> / <sub>16</sub> " )	280mm (11 <sup>1</sup> / <sub>32</sub> " )	30mm (1 <sup>1</sup> / <sub>16</sub> " )	0~25mm (0~1" )	OVER 420mm (OVER 16 <sup>17</sup> / <sub>32</sub> " )	5~10mm ( <sup>3</sup> / <sub>16</sub> "~ <sup>25</sup> / <sub>64</sub> " )	-5~5mm (- <sup>3</sup> / <sub>16</sub> "~ <sup>3</sup> / <sub>16</sub> " )

#### 3.4.2 WHEN USING INSTALLATION KITS

##### A. WINDOW REQUIREMENTS

This unit is designed for installation in standard double hung windows with actual opening widths from 68.58cm(27") to 99.09cm(39"). The top and bottom window sash must open sufficiently to allow a clear vertical opening of 40.64cm(16") from the bottom of the upper sash to the window stool.

##### B. INSTALLATION KITS CONTENTS

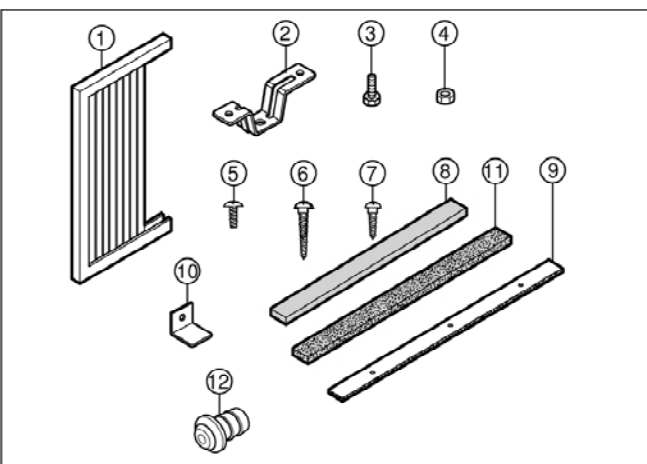
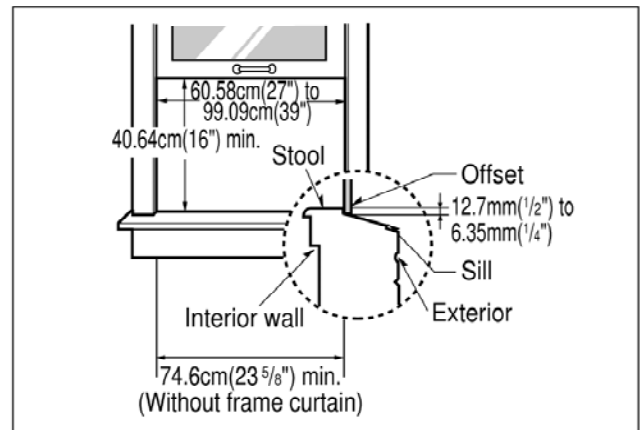

■ Top retainer bar is in the product package.

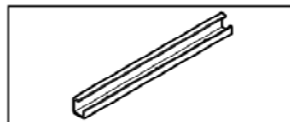

NO.	NAME OF PARTS	Q'TY
1	FRAME CURTAIN	2
2	SILL SUPPORT	2
3	BOLT	2
4	NUT	2
5	SCREW(TYPE A) [10mm( <sup>25</sup> / <sub>64</sub> " )]	16
6	SCREW(TYPE B) D5.1mm( <sup>3</sup> / <sub>16</sub> " ), 16mm( <sup>5</sup> / <sub>8</sub> " )	3
7	SCREW(TYPE C) D4.1mm( <sup>5</sup> / <sub>32</sub> " ), 16mm( <sup>5</sup> / <sub>8</sub> " )	5
8	FOAM-STRIP	1
9	FOAM-PE [600mm( <sup>23</sup> / <sub>32</sub> " ) x 25mm( <sup>1</sup> " ) x 2mm( <sup>1</sup> / <sub>16</sub> " )]	1
10	WINDOW LOCKING BRACKET	1
11	FOAM-PE [920mm( <sup>36</sup> / <sub>16</sub> " ) x 30mm( <sup>1</sup> / <sub>16</sub> " ) x 2mm( <sup>1</sup> / <sub>16</sub> " )]	1
12	DRAIN PIPE	1

## SUGGESTED TOOL REQUIREMENTS

**SCREWDRIVER(+, -), RULER, KNIFE, HAMMER, PENCIL, LEVEL**

### PREPARATION OF CHASSIS

1. Remove the screws which fasten the cabinet at both sides and at the back.
2. Slide the unit out from the cabinet by gripping the base pan handle and pulling forward while bracing the cabinet.
3. Remove EPS Material.
4. Cut the window sash seal to the proper length. Peel off the backing and attach the foam-pe ⑪ to the underside of the window sash.
5. Remove the backing from the top upper guide Foam PE ⑨ and attach it to the bottom of the upper guide.
6. Attach the upper guide onto the top of the cabinet with 3 type A screws.
7. Fasten the curtains to the unit with 4 Type A screws at the both sides.

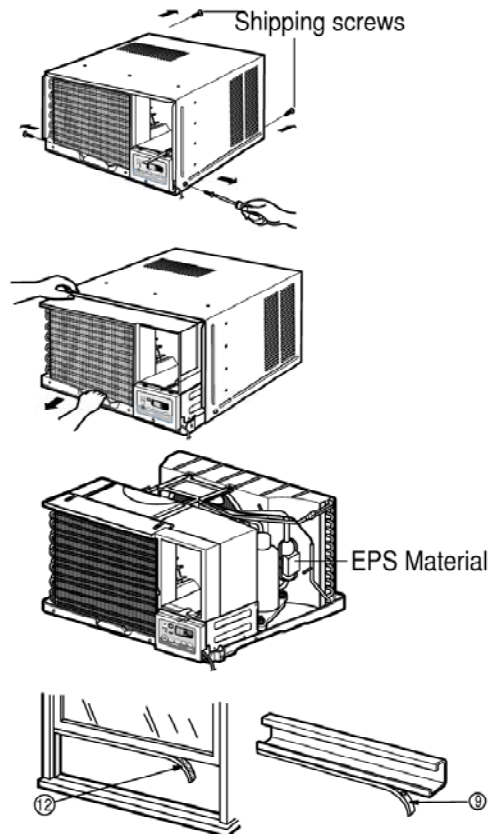

### CABINET INSTALLATION

1. Open the window. Mark a line on center of the window stool(or desired air conditioner location). Carefully place the cabinet on the window stool and align the center mark on the bottom front with the center line marked in the window stool.
2. Pull the bottom window sash down behind the upper guide until it meets.

#### NOTE:

- Do not pull the window sash down so tightly that the movement of Frame Curtain is restricted.

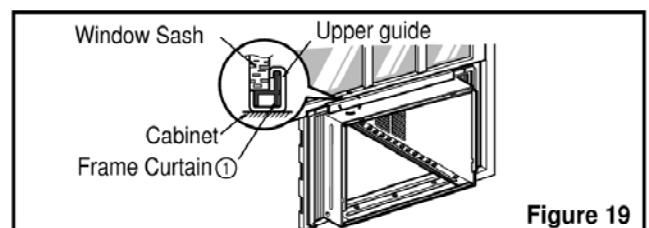
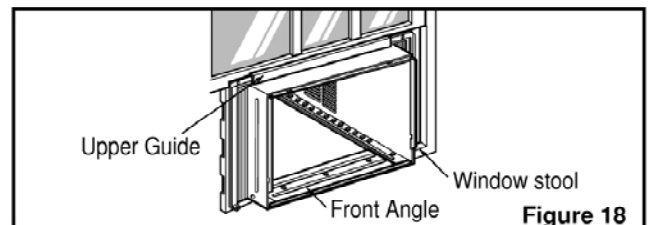
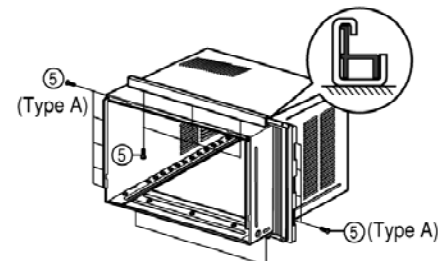

3. Loosely assemble the sill support using the parts in Figure 20.

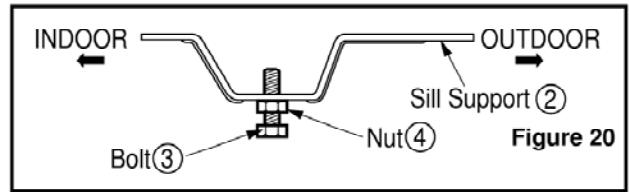

4. Select the position that will place the sill support near the outer most point on sill (See Figure 20)

5. Attach the sill support to the cabinet track hole in relation to the selected position using 2 Type A screws in each support (See Figure 21).

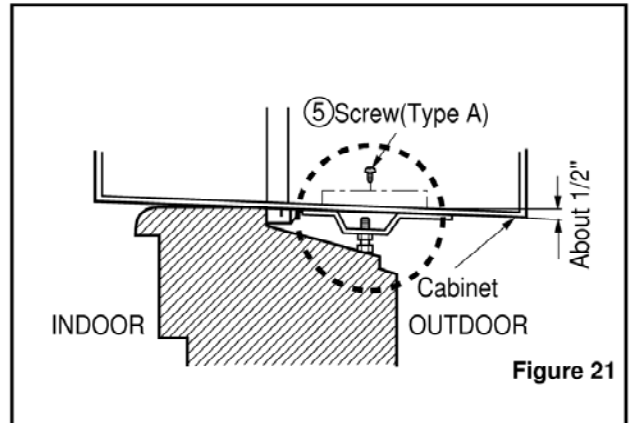

6. The cabinet should be installed with a very **slight tilt (about 12.7mm 1/2") downward** toward the outside (See Figure 22). Adjust the bolt and the nut of sill support for balancing the cabinet.

7. Attach the cabinet to the window stool by driving the screws (6)(Type B) through the front angle into window stool 16mm (5/8").

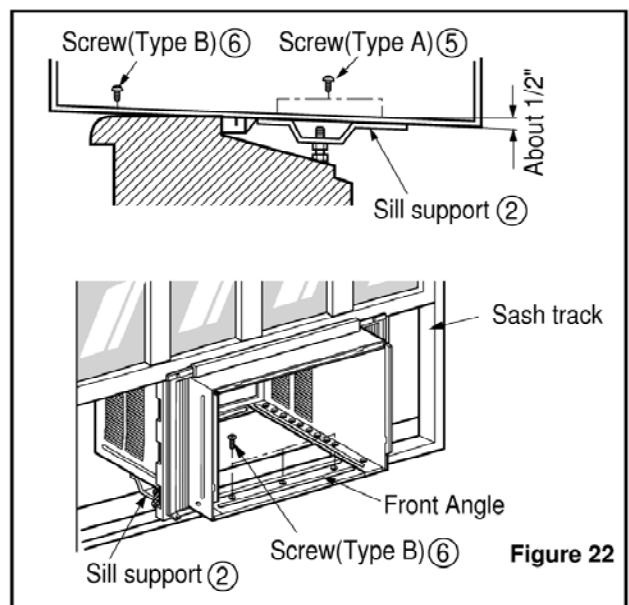

8. Pull each Frame curtain properly to each window sash track, and repeat step 2.

9. Attach each Frame curtain to the window sash by using screws (7)(Type C). (See Figure 23)

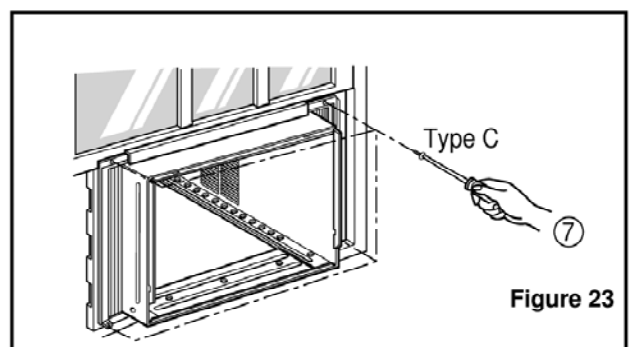



10. Slide the unit into the cabinet.(See Fig. 24)

**CAUTION:** For security purpose, reinstall screws at the cabinet's sides.

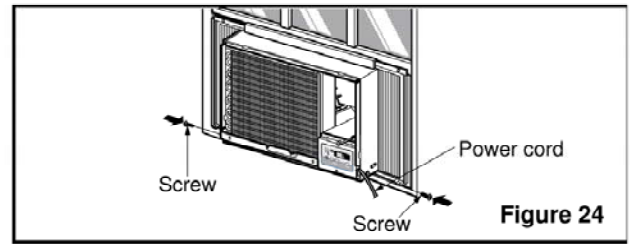

Figure 24

11. Cut the foam-strip ⑧ to the proper length and insert between the upper and lower window sash. (See Fig. 25)



Figure 25

12. Attach the window locking bracket ⑩ with a type C screw. (See Fig. 26)

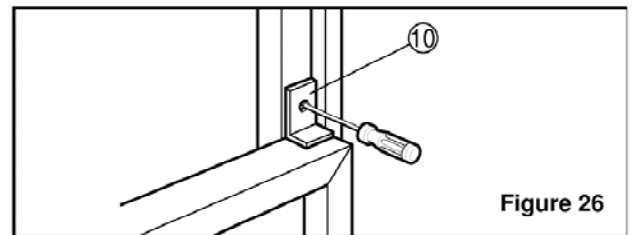
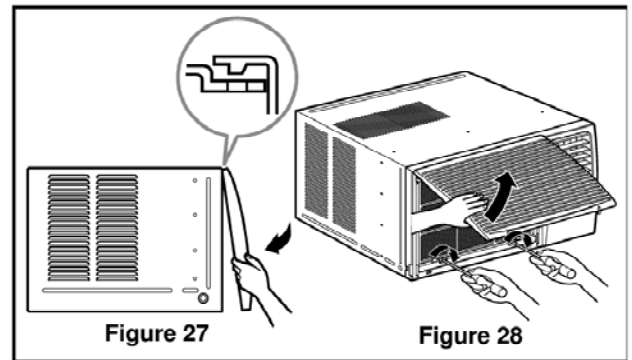

Figure 26

13. Attach the front grille to the cabinet by inserting the tabs on the grille into the tabs on the front of the cabinet. Push the grille in until it snaps into place.(See Fig. 27)



14. Lift the inlet grille and secure it with two type A screw through the front grille.(See Fig. 28)

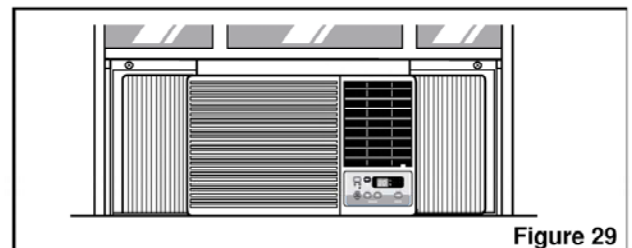
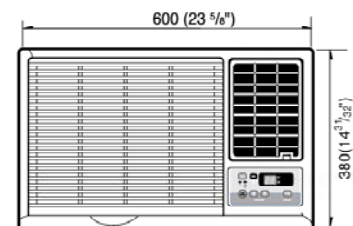
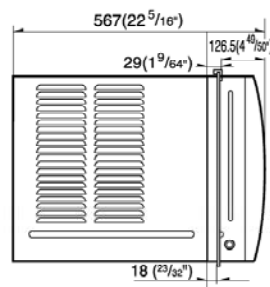

Figure 29

## 4. TROUBLESHOOTING GUIDE

### 4.1 OUTSIDE DIMENSIONS

unit: mm(inch)



### 4.2 PIPING SYSTEM

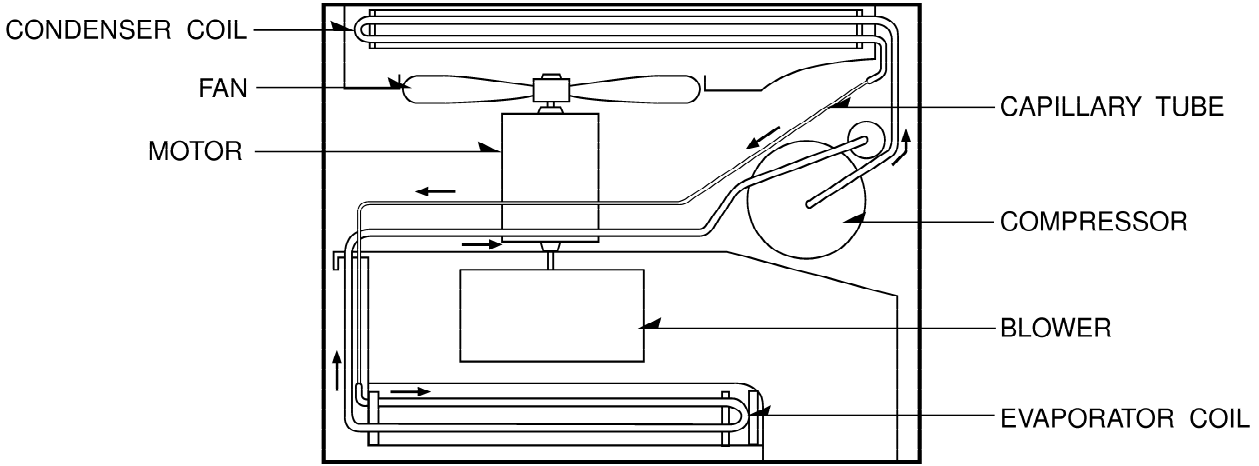
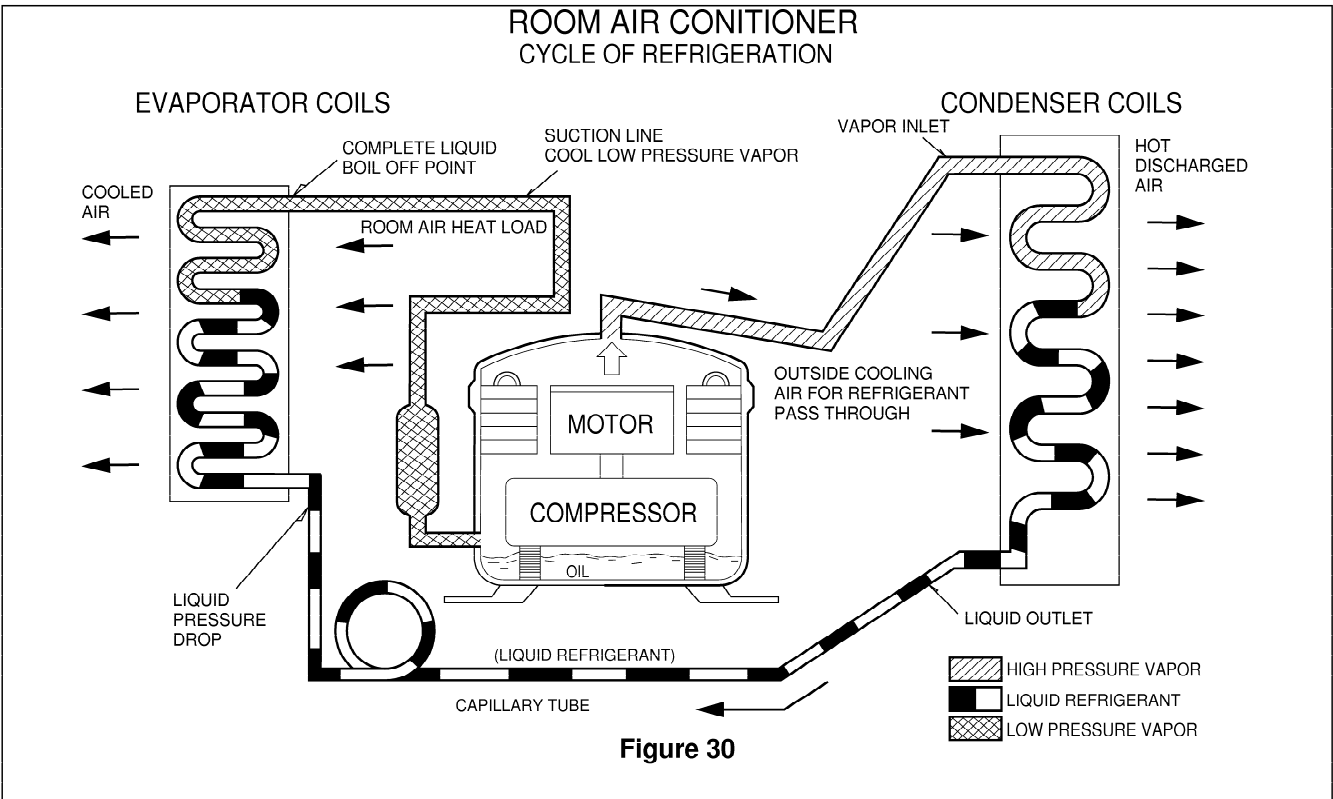

Figure 30 is a brief description of the important components and their function in what is called the refrigeration system. This will help you to understand the refrigeration cycle and the flow of the refrigerant in the cooling cycle.



### 4.3 TROUBLESHOOTING GUIDE

In general, possible trouble is classified in two kinds.

The one is called Starting Failure which is caused from an electrical defect, and the other is ineffective Air Conditioning caused by a defect in the refrigeration circuit and improper application.

**Unit runs but poor cooling.**

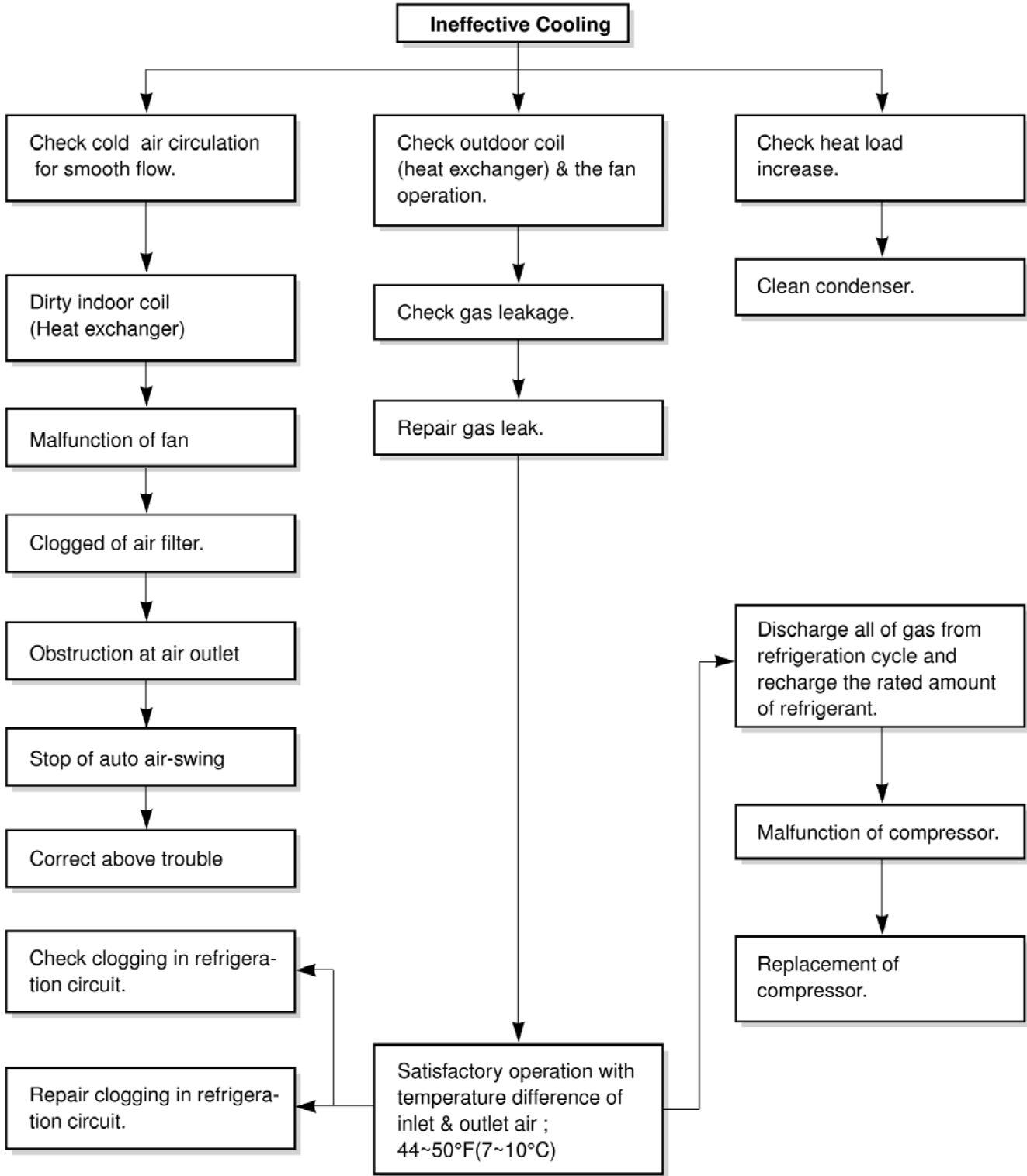

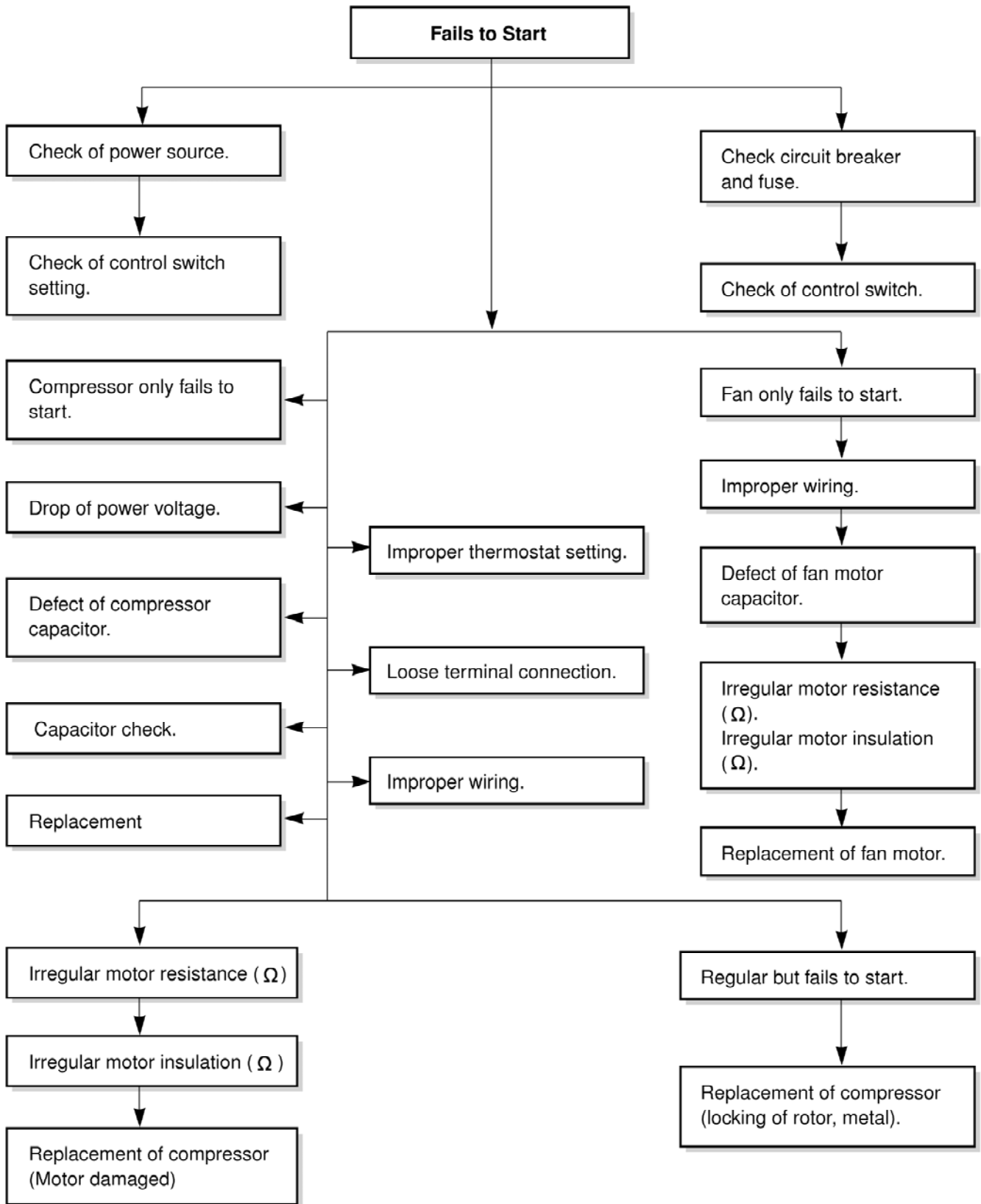

■ ELECTRICAL PARTS TROUBLESHOOTING GUIDE: CW-XC80HU

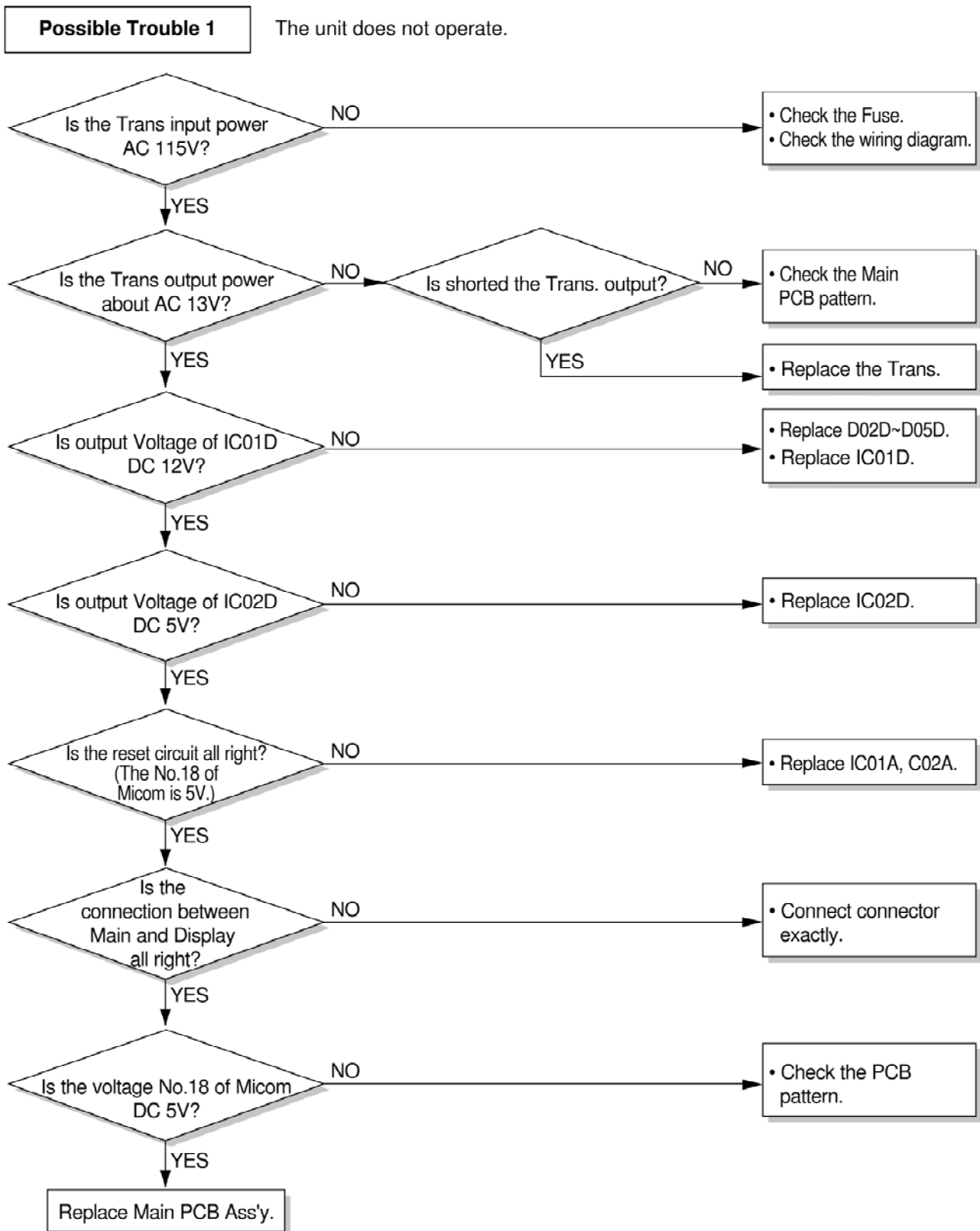

**Possible Trouble 2**

The compressor does not operate.

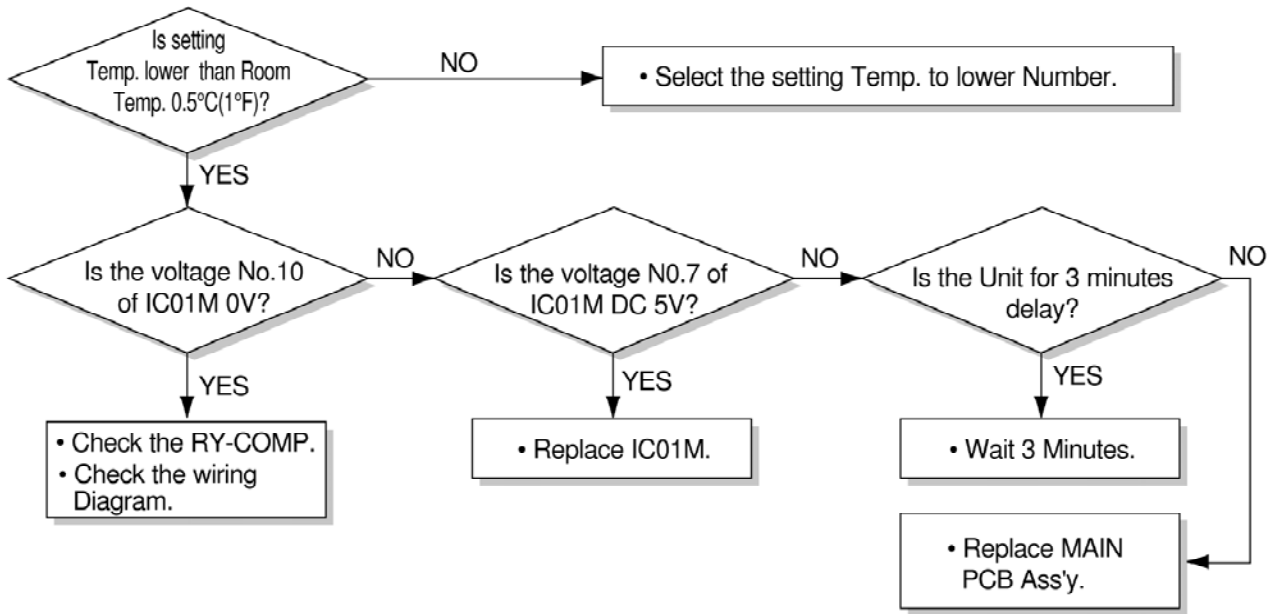

**Possible Trouble 3**

The compressor always operate.

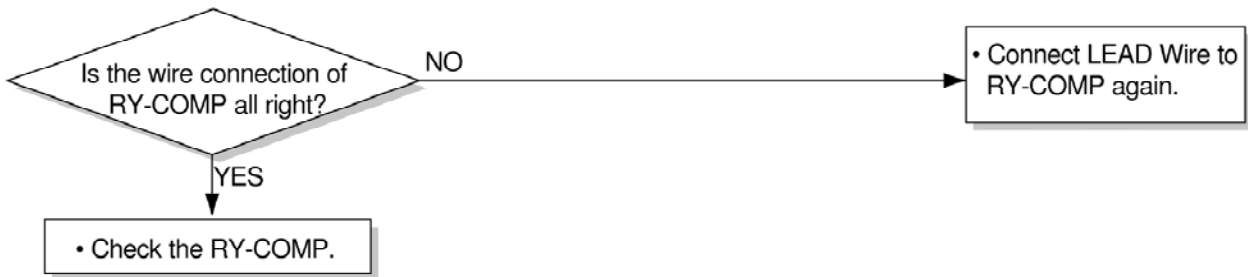

**Possible Trouble 4**

FAN does not operate.

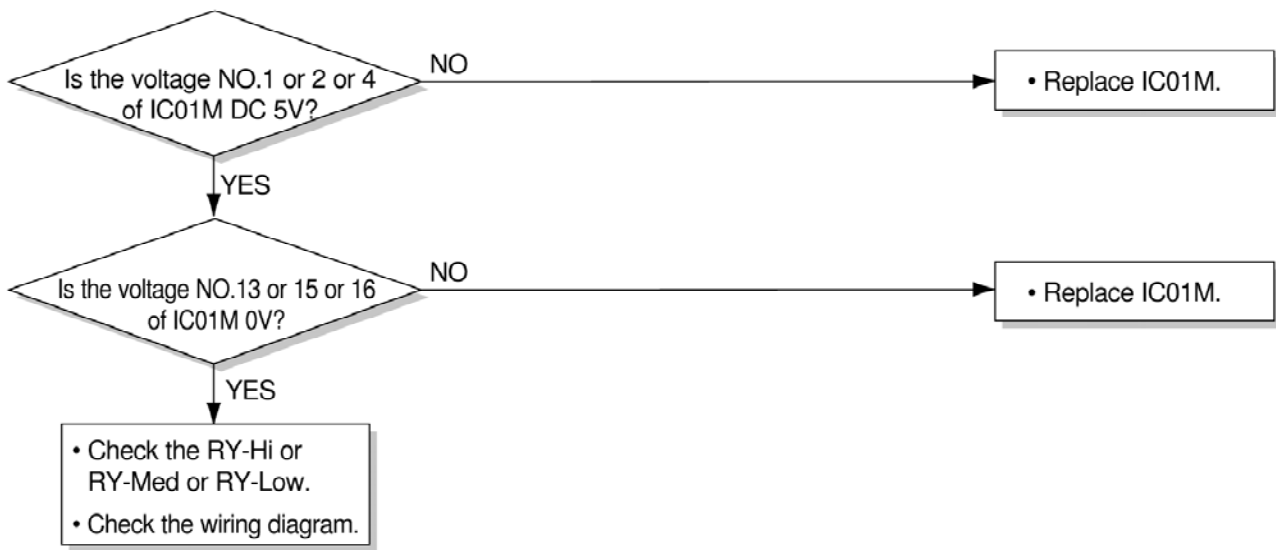

**Possible Trouble 5**

Remote controller does not operate.

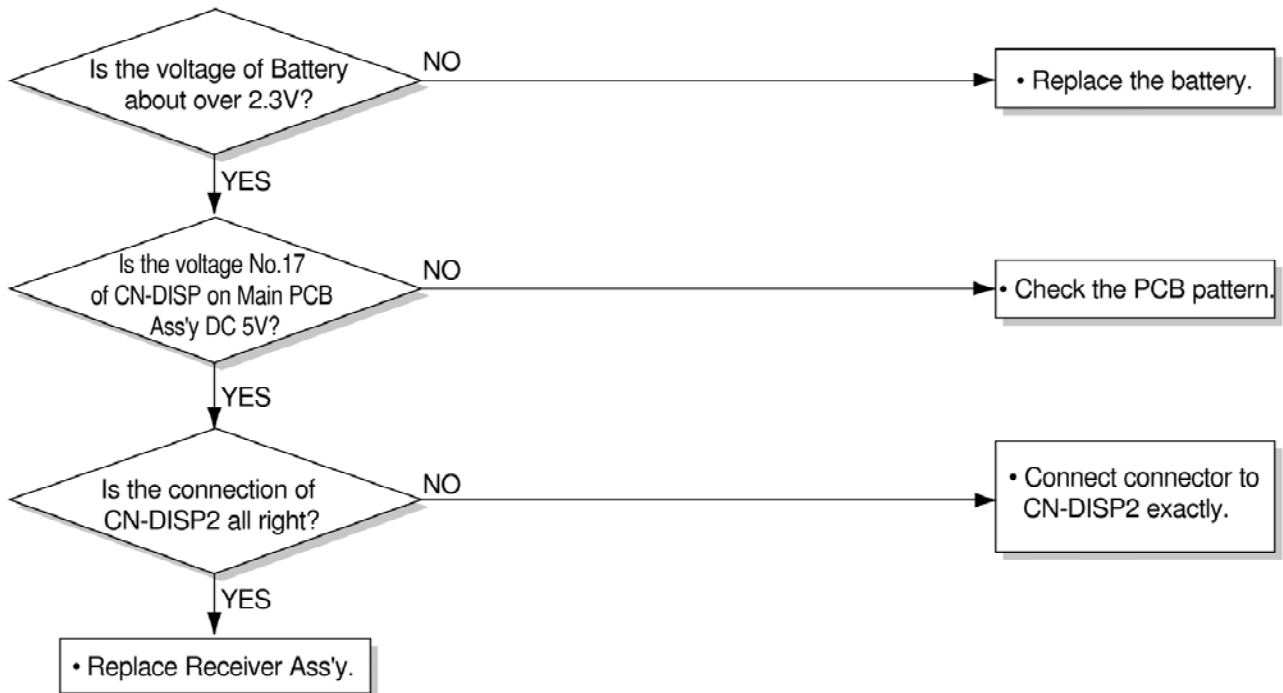
**Possible Trouble 6**

It displays abnormally on display PCB Ass'y.

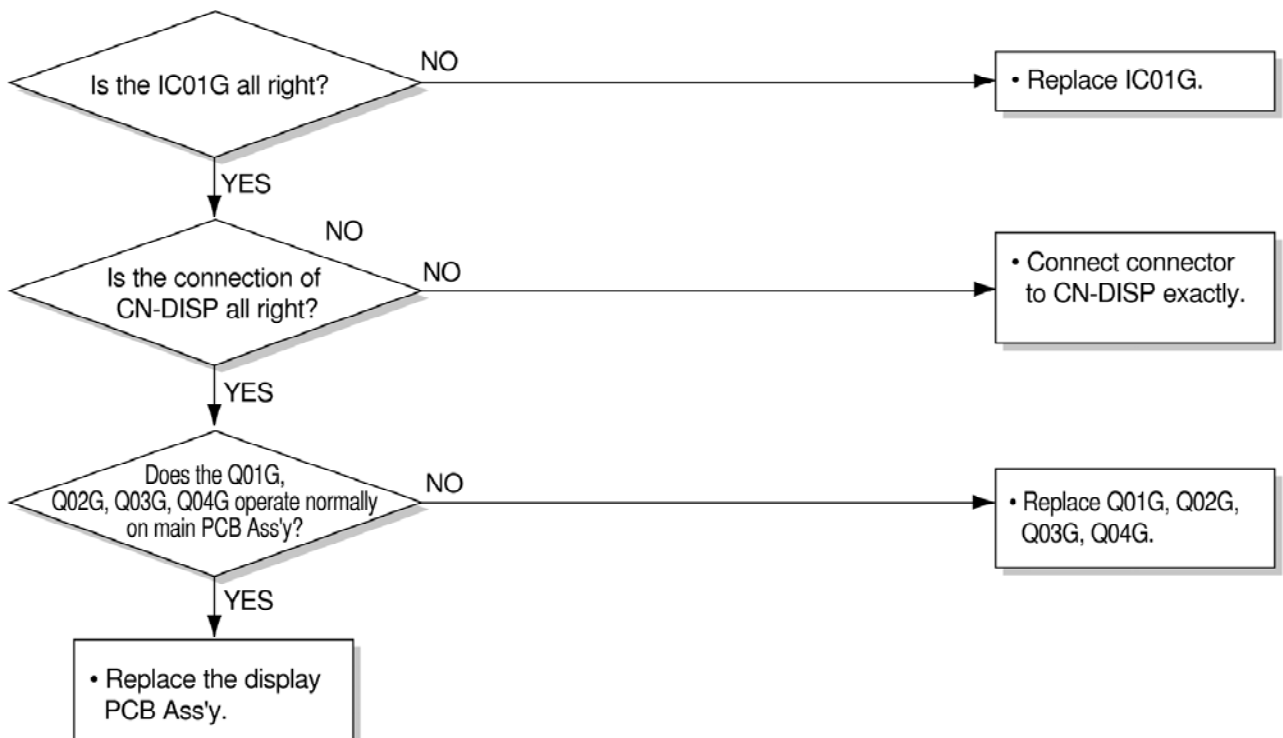



<b>COMPLAINT</b>	<b>CAUSE</b>	<b>REMEDY</b>
Fan motor will not run.	No power	Check voltage at outlet. Correct if none.
	Power supply cord	Check voltage to control box. If none, check power supply cord. Replace cord if circuit is open.
	Wire disconnected or connection loose	Connect wire. Refer to wiring diagram for terminal identification. Repair or replace loose terminal.
	Capacitor (Discharge capacitor before testing.)	Test capacitor. Replace if not within $\pm 10\%$ of manufacturer's rating. Replace if shorted, open, or damaged.
	Will not rotate	Fan blade hitting shroud or blower wheel hitting scroll. Realign assembly.  Units using slinger ring for condenser fan must have $\frac{1}{4}$ to $\frac{5}{16}$ inch clearance to the base. If it hits the base, shim up the bottom of the fan motor with mounting screw(s).  Check fan motor bearings; if motor shaft will not rotate, replace the motor.
Fan motor runs intermittently	Revolves on overload.	Check voltage. If not within limits, call an electrician.  Test capacitor. Check bearings. Does the fan blade rotate freely? If not, replace fan motor.  Pay attention to any change from high speed to low speed. If the speed does not change, replace the motor.
Fan motor noise.	Fan	If cracked, out of balance, or partially missing, replace it.
	Turbo	If cracked, out of balance, or partially missing, replace it.
	Loose clamper	Tighten it.
	Worn bearings	If knocking sounds continue when running or loose, replace the motor. If the motor hums or noise appears to be internal while running, replace motor.
Compressor will not run, but fan motor runs.	Voltage	Check voltage. If not within limits, call an electrician.
	Wiring	Check the wire connections, if loose, repair or replace the terminal. If wires are off, refer to wiring diagram for identification, and replace. Check wire locations. If not per wiring diagram, correct.
	Thermistor	Check the TEMP control. If not at the lowest number, set TEMP control to this setting and restart the unit.  Check the continuity of the thermistor. Replace the thermistor if the circuit is open.

<b>COMPLAINT</b>	<b>CAUSE</b>	<b>REMEDY</b>
Compressor will not run, but fan motor runs.	Capacitor (Discharge capacitor before servicing.)	Check the capacitor. Replace if not within $\pm 10\%$ of manufacturers rating. Replace if shorted, open, or damaged.
	Compressor	Check the compressor for open circuit or ground. If open or grounded, replace the compressor.
	Overload	Check the compressor overload, if externally mounted. Replace if open. (If the compressor temperature is high, remove the overload, cool it, and retest.)
Compressor cycles on overload.	Voltage	Check the voltage. If not within limits, call an electrician.
	Overload	Check overload, if externally mounted. Replace if open. (If the compressor temperature is high, remove the overload, cool, and retest.)
Compressor cycles on overload.	Fan motor	If not running, determine the cause. Replace if required.
	Condenser air flow restriction	Remove the cabinet. inspect the interior surface of the condenser; if restricted, clean carefully with a vacuum cleaner (do not damage fins) or brush. Clean the interior base before reassembling.
	Condenser fins (damaged)	If condenser fins are closed over a large area on the coil surface, head pressures will increase, causing the compressor to overload. Straighten the fins or replace the coil.
Compressor cycles on overload.	Capacitor	Test capacitor.
	Wiring	Check the terminals. If loose, repair or replace.
	Refrigerating system	Check the system for a restriction.
Insufficient cooling or heating	Air filter	If restricted, clean or replace.
	Exhaust damper door	Close if open.
	Unit undersized	Determine if the unit is properly sized for the area to be cooled.
Excessive noise	Turbo or fan	Check the set screw or clamp. If loose or missing, correct. If the turbo or fan is hitting air guide, rearrange the air handling parts.
	Copper tubing	Remove the cabinet carefully and rearrange tubing not to contact cabinet, compressor, shroud, and barrier.

# 5. SCHEMATIC DIAGRAM

## 5.1 CIRCUIT DIAGRAM

■ MODEL : CW-XC100HU, CW-XC120HU

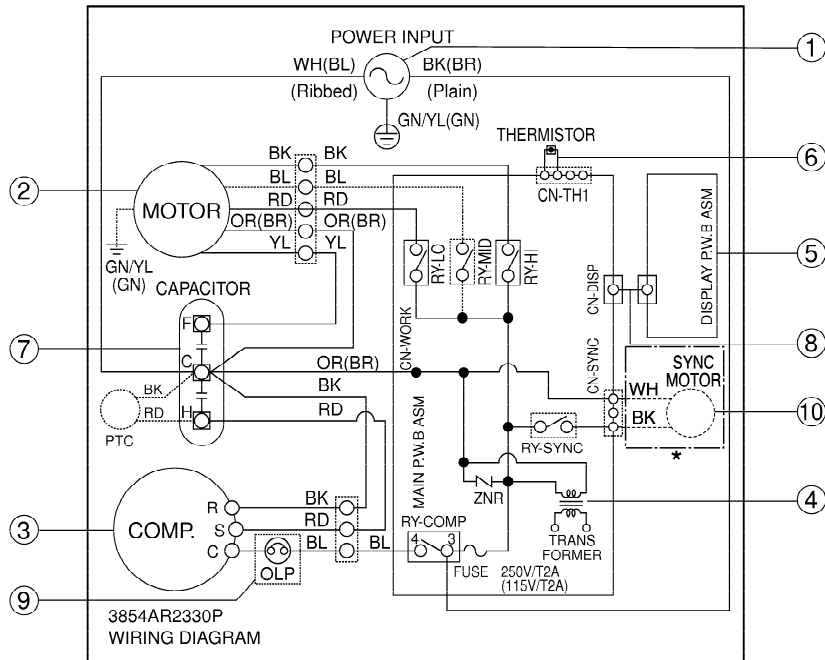

Remarks: \* mark parts are not equipped on this model.

LOCATION NO.	DESCRIPTION	Q'TY PER SET
1	POWER CORD ASSY	1
2	MOTOR ASSY	1
3	COMPRESSOR	1
4	MAIN P.C.B ASSY	1
5	DISPLAY P.C.B ASSY	1
6	THERMISTOR	1
7	CAPACITOR	1
8	CONNECTOR ASSY	1
9	OVERLOAD PROTECTOR	1

## 5.2 ELECTRONIC CONTROL DEVICE

### ■ MODEL: CW-XC100HU, CW-XC120HU

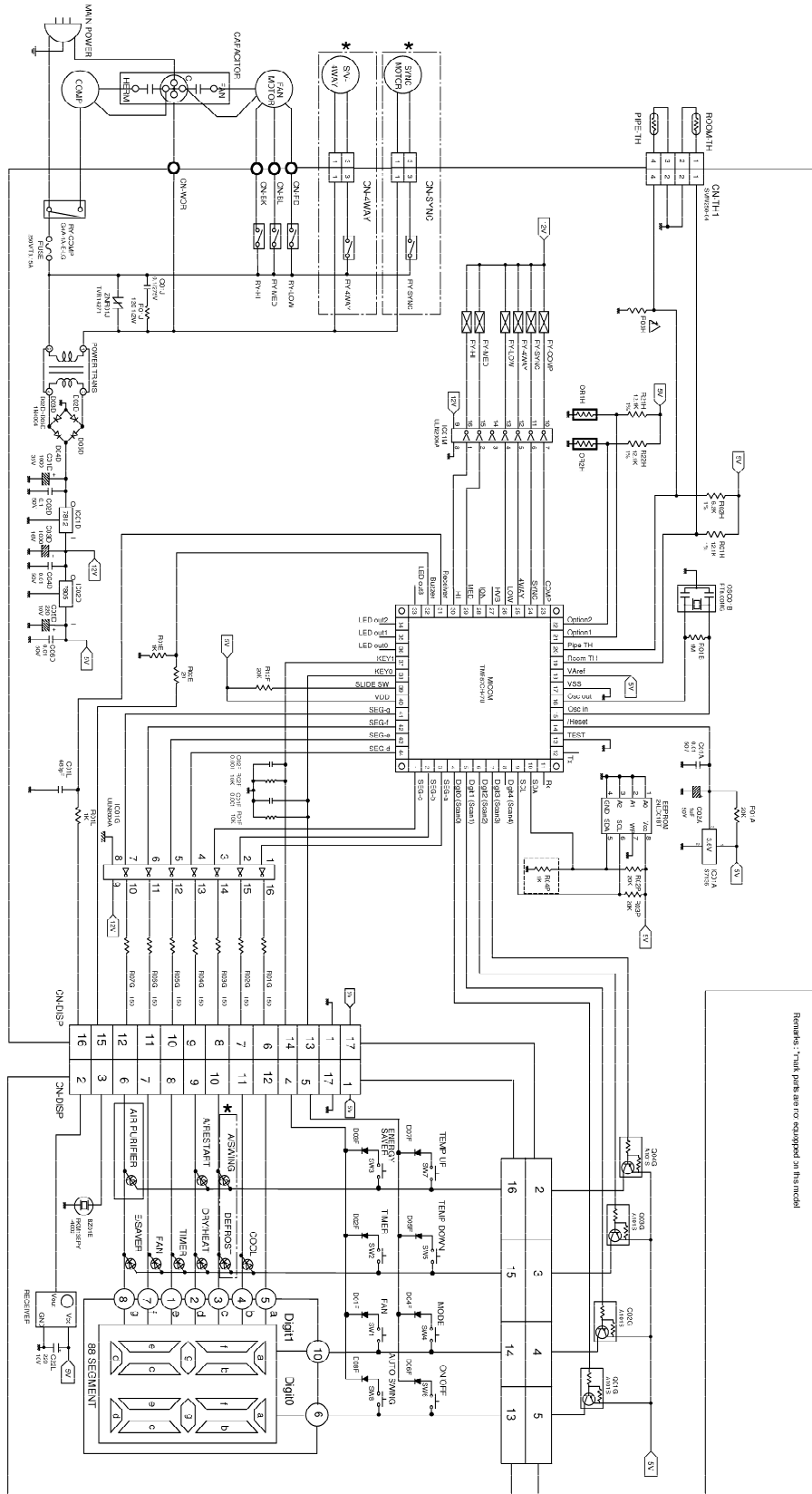

Remarks: \*mark parts are not equipped in this model

NOTE  
 1. The unit of unstated resistance is ohm (Ω), 55c.  
 2. The unit of unstated capacitor is nFpF.



# 6. EXPLODED VIEW

■ MODEL: CW-XC100HU, CW-XC120HU

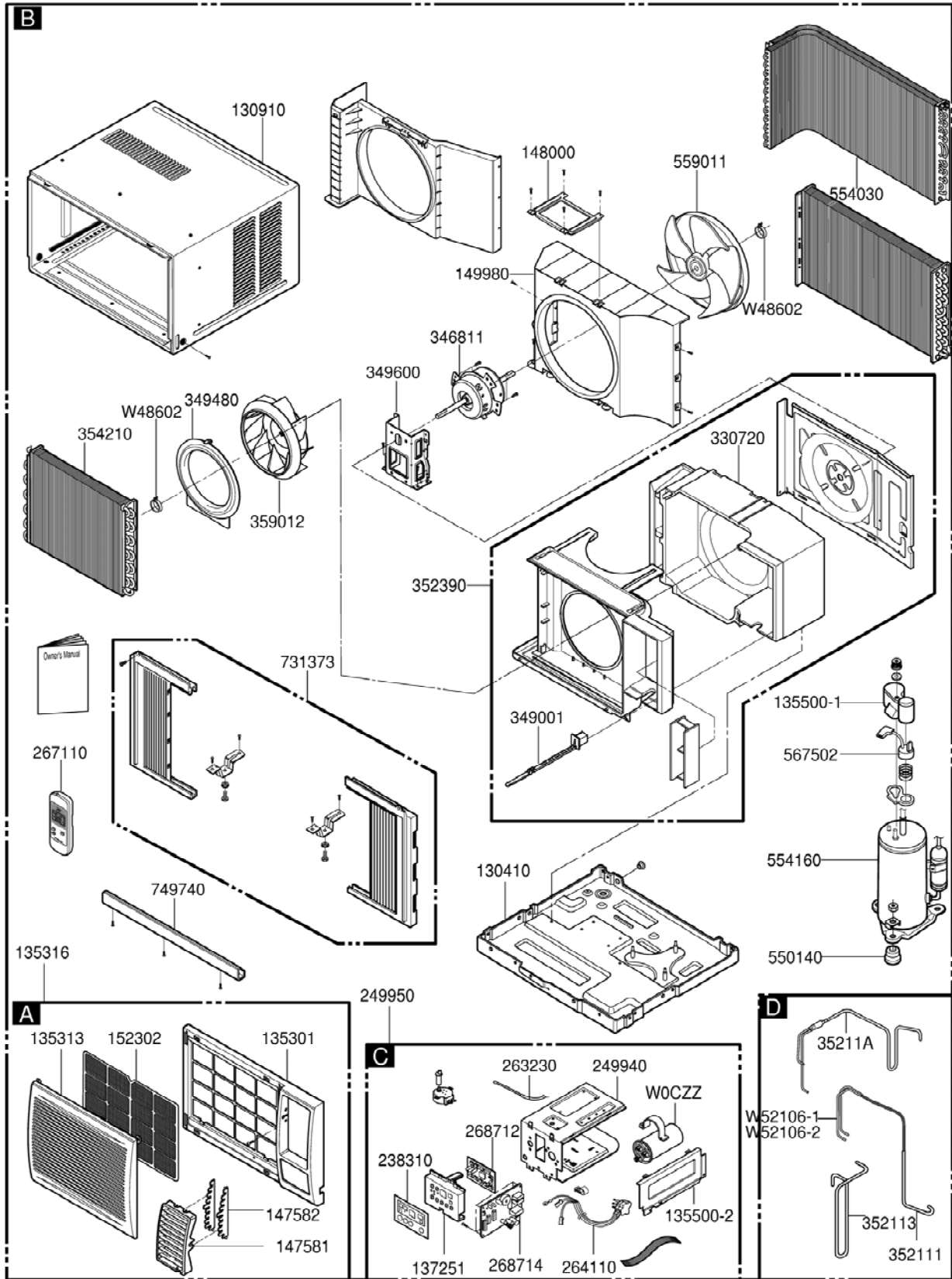

## 7. REPLACEMENT PARTS LIST

R : Recommendable parts.

LOCATION NO.	DESCRIPTION	PART NO.		REMARK
		CW-XC100HU	CW-XC120HU	
<b>A</b>	FRONT GRILLE ASS'Y	CW353110188B	CW353110188B	
1	GRILLE, FRONT	CW353010136B	CW353010136B	
2	INLET, GRILLE	CW353010137B	CW353010137B	
3	AIR FILTER ASS'Y	CW5231R1152M	CW5231R1152M	
4	HORIZONTAL LOUVER	CW4758R2196B	CW4758R2196B	
5	VERTICAL LOUVER	CW4758R3307C	CW4758R3307C	
<b>B</b>	COMP & ACCESSORY ASS'Y			
1	ANTI-VIBRATION BUSH	CW4830R4335A	CW4830R4335A	
2	COMPRESSOR	CW2520KAC2JA	CW2520KQC2AA	
3	GASKET	CW4986-L001G	CW4986-L001G	
4	OVERLOAD PROTECTOR	CW6750-L031A	CW6750-L067A	
5	TERMINAL COVER	CWL00018	CWL00018	
6	BASE PAN WELD ASS'Y	CW304120012S	CW304120012S	
7	BARRIER, SINGLE	CW479020022A	CW479020022A	
8	SCROLL	CW307220001A	CW307220001A	
9	AIR GUIDE ASSEMBLY	CW523910006E	CW523910006E	
10	CABINET ASS'Y	CW309110032R	CW309110032T	
11	DAMPER, VENTILATION	CW4900R7024B	CW4900R7024B	
12	MOUNT, MOTOR	CW496020005A	CW496020005A	
13	MOTOR ASSEMBLY, SINGLE	CW468120073E	CW468120073B	
14	SHROUD	CW4998R1496A	CW4998R1496A	
15	FAN, TURBO	CW590020030A	CW590020030A	
16	FAN, AXIAL	CW590010009B	CW590010009B	
17	CLAMP, SPRING	CWL00027	CWL00027	
18	ORIFICE	CW494810005A	CW494810005A	
19	BRACE	CW480010001A	CW480010001A	
20	EVAPORATOR ASSEMBLY, FIRST	CW5421R6086B	CW5421R2912C	
21	CONDENSER ASSEMBLY, FIRST	CW5403R2921A	CW5403R2921A	
22	REMOTE CONTROLLER ASSEMBLY	CW671190018C	CW671190018C	
23	OPERATING INSTRUCTION	CW382820391K	CW382820391K	
24	INSTALLATION KIT	CW312710015T	CW312710015T	
25	UPPER GUIDE	CW4974R3262E	CW4974R3262E	

LOCATION NO.	DESCRIPTION	PART NO.		REMARK
		CW-XC100HU	CW-XC120HU	
<b>C</b>	CONTROL BOX ASSEMBLY	CW499520326U	CW499520326E	
1	CONTROL BOX , SINGLE	CW4994R1221A	CW4994R1221A	
2	CONTROL PANEL	CW372010003A	CW372010003A	
3	ESCUTCHEON	CW383120034V	CW383120034V	
4	CAPACITOR	CW6120R2194F	CW0CZZ20001N	
5	POWER CORD ASS'Y	CW2H00677R	CW2H00677S	
6	THERMISTOR	CW632320003D	CW632320003D	
7	COVER	CW3550R7032A	CW3550R7032A	
8	MAIN P.C.B ASS'Y	CW687110070Q	CW687110070Q	
9	DISPLAY P.C.B ASS'Y	CW687120195R	CW687120195R	
10	CABLE, FLAT	CW685090001H	CW685090001H	
<b>D</b>	PIPE			
1	TUBE ASSEMBLY, SUCTION INDOOR	CW5211R6081D	CW5211R2926A	
2	TUBE ASSEMBLY, DISCHARGE SINGLE	CW5211R2930A	CW5211R2930A	
3	TUBE, EVAPORATOR	CW5210R7062A	CW5210R7090B	
4	TUBE, EVAPORATOR	CW5210R7063A	CW5210R4373B	
5	TUBE ASSEMBLY, CONNECTOR	CW5211R7059A	CW5211R7059A	
6	TUBE, CAPILLARY	CW3E92334K	CW5424R3411E	



# MEMO

---

A series of horizontal dotted lines for writing.



