



Internal Use Only

<http://biz.lgservice.com>

Room Air Conditioner

SVC MANUAL(Exploded View)

**MODEL : LWC1031DAG/DAS, LWC1213AAS/ACG/AAG
Y5USC12-6A, LWC1232ACG/DAG/ACP/AAS/DAS
LWC1232A5S, HBLG1200H
LWC1430AAG, R1404
LWC143CSAA0**

CAUTION

Before Servicing the unit, read the safety precautions in General SVC manual.
Only for authorized service personnel.

CONTENTS

1. PREFACE

1.1 SAFETY PRECAUTIONS.....	2
1.2 INSULATION RESISTANCE TEST.....	2
1.3 SPECIFICATIONS.....	3
1.4 FEATURES.....	5
1.5 CONTROL LOCATIONS	5

2. DISASSEMBLY INSTRUCTIONS

2.1 MECHANICAL PARTS	6
2.1.1 FRONT GRILLE	6
2.1.2 CABINET	6
2.1.3 CONTROL BOX	6
2.2 AIR HANDLING PARTS	7
2.2.1 AIR GUIDE AND BLOWER	7
2.2.2 FAN	7
2.2.3 SHROUD	8
2.3 ELECTRICAL PARTS.....	8
2.3.1 OVERLOAD PROTECTOR	8
2.3.2 COMPRESSOR.....	8
2.3.3 CAPACITOR.....	9
2.3.4 POWER CORD	9
2.3.5 THERMOSTAT	9
2.3.6 ROTARY SWITCH	9
2.3.7 MOTOR	10

2.4 REFRIGERATION CYCLE	10
2.4.1 CONDENSER.....	10
2.4.2 EVAPORATOR.....	10
2.4.3 CAPILLARY TUBE	11

3. INSTALLATION

3.1 SELECT THE BEST LOCATION.....	13
3.2 CHECK OF INSTALLATION.....	13
3.3 HOW TO DRAIN.....	13
3.4 HOW TO INSTALL	14
3.4.1 WHEN USING GASKET.....	15
3.4.2 WHEN USING INSTALLATION KITS...	15
3.5 SUGGESTED TOOL REQUIREMENTS	16
3.6 CABINET INSTALLATION.....	16

4. TROUBLESHOOTING GUIDE

4.1 OUTSIDE DIMENSIONS	18
4.2 PIPING SYSTEM.....	19
4.3 TROUBLESHOOTING GUIDE	20

5. SCHEMATIC DIAGRAM

5.1 CIRCUIT DIAGRAM	24
---------------------------	----

6. EXPLODED VIEW

1. PREFACE

This **SERVICE MANUAL** provides various service information, including the mechanical and electrical parts etc. This room air conditioner was manufactured and assembled under a strict quality control system. The refrigerant is charged at the factory. Be sure to read the safety precautions prior to servicing the unit.

1.1 SAFETY PRECAUTIONS

1. When servicing the unit, set the **ROTARY SWITCH** or **POWER SWITCH** to **OFF** and unplug the power cord.
2. Observe the original lead dress.
If a short circuit is found, replace all parts which have been overheated or damaged by the short circuit.
3. After servicing the unit, make an insulation resistance test to protect the customer from being exposed to shock hazards.

1.2 INSULATION RESISTANCE TEST

1. Unplug the power cord and connect a jumper between 2 pins (black and white).
2. The grounding conductor (green) is to be open.
3. Measure the resistance value with an ohm meter between the jumpered lead and each exposed metallic part on the equipment at all the positions (except **OFF**) of the **ROTARY SWITCH**.
4. The value should be over 1M Ω .

1.3 SPECIFICATIONS

ITEMS	MODELS		LWC1031DAG/ DAS	LWC1232AAS/DAG LWC1232ACG/ACP Y5USC12-6A	LWC1232A5S	HBLG1200H	LWC1232DAS
	POWER SUPPLY			1Ø,230V,60Hz	1Ø,220V,60Hz		1Ø,208/230V,60Hz
COOLING CAPACITY	(Btu/h)	10,055	12,000		11,500/12,000		
INPUT	(W)	1,030	1,220		1,250/1,220		1,200
RUNNING CURRENT	(A)	5	5.5		6.2/5.5		5.8
E.E.R	(BTU/W.h)	10.3kJ/W,h	9.8				9.7
HEATING CAPACITY	(Btu/h)	-	-	11,200	9,200/11,200		-
INPUT	(W)	-	-	3,500	2,900/3,500		-
RUNNING CURRENT	(A)	-	-	15.3	14/15.3		-
OPERATING CONDITION	INDOOR (°C)	26.7(DB)* 19.4(WB)**					
	OUTDOOR (°C)	35(DB)* 23.9(WB)**					
REFRIGERANT (R-22) CHARGE		510g(18.0oz)	555g(19.4oz)				
EVAPORATOR		2R 16S,SLIT-FIN TYPE	2R 13S,LOUVERED-FIN TYPE				
CONDENSER		2R 17S,LOUVERED-FIN TYPE					
FAN, INDOOR		BLOWER					
FAN, OUTDOOR		PROPELLER TYPE FAN WITH SLINGER-RING					
FAN SPEEDS, FAN/COOLING/HEATING		2/3	2/3	1/2/2		2/3	
FAN MOTOR		6 POLES					
OPERATION CONTROL		ROTARY SWITCH OR ROCKER SWITCH					
ROOM TEMP. CONTROL		THERMOSTAT					
AIR DIRECTION CONTROL		VERTICAL LOUVER(RIGHT & LEFT)					
		HORIZONTAL LOUVER (UP & DOWN)					
CONSTRUCTION		SLIDE IN-OUT CHASSIS					
ELECTRIC HEATER		-	-	3.5kW, 230V		-	
PROTECTOR	COMPRESSOR	OVERLOAD PROTECTOR					
	FAN MOTOR	INTERNAL THERMAL PROTECTOR					
	ELECTRIC HEATER	-	-	FUSE LINK,BINETAL THERMOSTAT		-	
POWER CORD		(3 WIRE WITH GROUNDING)					
		ATTACHMENT PLUG(CORD-CONNECTED TYPE)					
DRAIN SYSTEM		DRAIN PIPE OR SPLASHED BY FAN SLINGER					
NET WEIGHT	(lbs/kg)	90.4/41	97/44				
OUTSIDE DIMENSION (W x H x D)	(inch)	23 5/8 x 14 31/32 x 22 5/16					
	(mm)	600 x 380 x 567					

* DB:Dry Bulb

**WB:Wet Bulb

NOTE: Please refer to Label Quality on the product since this specification may be changed for improving performance.

ITEMS	MODELS		
	LWC1213AAS/ACG/AAG	LWC1430AAG	R1404/LWC143CSAA0
POWER SUPPLY	1Ø, 115V, 60Hz	1Ø, 220V, 60Hz	1Ø, 115V, 60Hz
COOLING CAPACITY (Btu/h)	12,000	14,000	14,000
INPUT (W)	1,220	1,400	1,380
RUNNING CURRENT (A)	11	6.2	12
E.E.R (BTU/W.h)	9.8	10	10.1
HEATING CAPACITY (Btu/h)	-	-	-
INPUT (W)	-	-	-
RUNNING CURRENT (A)	-	-	-
OPERATING CONDITION	INDOOR (°C)	26.7(DB)* 19.4(WB)**	
	OUTDOOR (°C)	35(DB)* 23.9(WB)**	
REFRIGERANT (R-22) CHARGE	530g(18.7oz)	670g(23.6oz)	550g(19.4oz)
EVAPORATOR	2R 16S SLIT-FIN TYPE	2R 13S SLIT-FIN TYPE	2R 13S,SLIT-FIN TYPE
CONDENSER	2R 17S LOUVERED-FIN TYPE	2R 14S LOUVERED-FIN TYPE	2R 17S,LOUVERED-FIN TYPE
FAN, INDOOR	TURBO FAN	BLOWER	TURBO FAN
FAN, OUTDOOR	PROPELLER TYPE FAN WITH SLINGER-RING		
FAN SPEEDS, FAN/COOLING/HEATING	2/3		
FAN MOTOR	6 POLES		
OPERATION CONTROL	ROTARY SWITCH OR ROCKER SWITCH		
ROOM TEMP. CONTROL	THERMOSTAT		
AIR DIRECTION CONTROL	VERTICAL LOUVER(RIGHT & LEFT)		
	HORIZONTAL LOUVER (UP & DOWN)		
CONSTRUCTION	SLIDE IN-OUT CHASSIS		
ELECTRIC HEATER	-		
PROTECTOR	COMPRESSOR	OVERLOAD PROTECTOR	
	FAN MOTOR	INTERNAL THERMAL PROTECTOR	
	ELECTRIC HEATER	-	
POWER CORD	(3 WIRE WITH GROUNDING)		
	ATTACHMENT PLUG(CORD-CONNECTED TYPE)		
DRAIN SYSTEM	DRAIN PIPE OR SPLASHED BY FAN SLINGER		
NET WEIGHT (lbs/kg)	95/43		93/42
OUTSIDE DIMENSION (W x H x D)	(inch)	23 ⁵ / ₈ x 14 ³¹ / ₃₂ x 22 ⁵ / ₁₆	
	(mm)	600 x 380 x 567	

* DB: Dry Bulb

**WB: Wet Bulb

NOTE: Please refer to Label Quality on the product since this specification may be changed for improving performance.

1.4 FEATURES

- Designed for COOLING ONLY.
- Powerful and whispering cooling.
- Slide-in and slide-out chassis for the simple installation and service.
- Side air-intake, side cooled-air discharge.

- Built-in adjustable THERMOSTAT
- Washable one-touch filter
- Compact size
- Reliable and efficient rotary compressor is equipped.

1.5 CONTROL LOCATIONS

1.5.1 COOLING ONLY MODEL

• VENTILATION

The ventilation lever must be in the CLOSE position in order to maintain the best cooling conditions.

When a fresh air is necessary in the room, set the ventilation lever OPEN position.

The damper is opened and room air is exhausted.

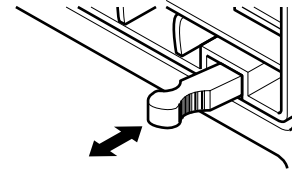

CLOSE **VENT** **OPEN**

• THERMOSTAT

Thermostat will automatically control the temperature of the room. Select a higher number for a cooler temperature in the room. The temperature is selected by positioning the knob to the desired position.

The **5** or **6** position is a normal setting for average conditions.

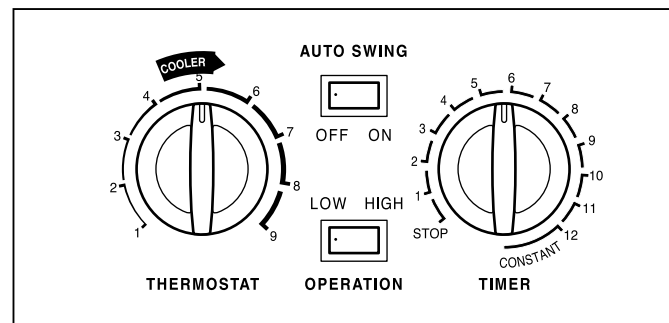

• OPERATION

Off - Turns air conditioner off.

Med Fan - Med speed fan operation without cooling.

Low Fan - Low speed fan operation without cooling.

High Cool - Cooling with high speed fan operation.

Med Cool - Cooling with med speed fan operation.

Low Cool - Cooling with low speed fan operation.

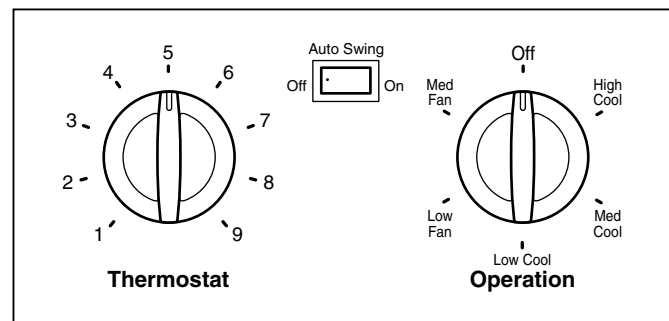

• OPERATION

Off (○) : Turns the air conditioner off.

Low Fan (⊕) : Permits the low fan speed operation without cooling (heating).

Low Cool (✱) : Permits cooling with the low fan speed operation.

High Cool (✱✱) : Permits cooling with the high fan speed operation.

Low Heat (⊙) : Permits heating with the low fan speed operation.

High Heat (⊙⊙) : Permits heating with the high fan speed operation.

• Auto Swing (For R1403/WR1210)

On: Air Swing is operated while operation knob is set to the Cool position

Off: Stops the operation of air swing.

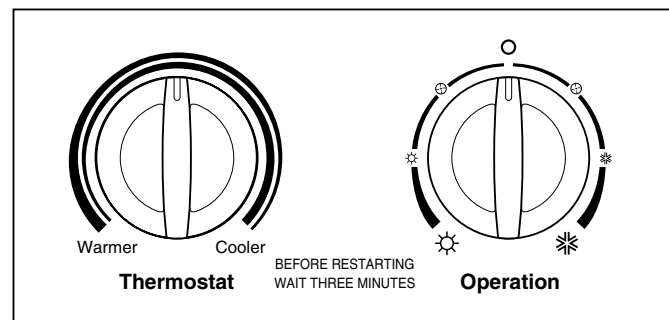

* Panel design can differ according to the model.

A slight heat odor may come from the unit when first switching to HEAT after the cooling season is over. This odor, caused by fine dust particles on the heater, will disappear quickly.

2. DISASSEMBLY INSTRUCTIONS

— Before the following disassembly, POWER SWITCH set to OFF and disconnect the power cord.

2.1 MECHANICAL PARTS

2.1.1 FRONT GRILLE

1. Open the Inlet grille upward .
2. Remove the screw which fastens the front grille.
3. Pull the front grille from the right side.
4. Remove the front grille.
5. Re-install the component by referring to the removal procedure, above.(See Figure 1)

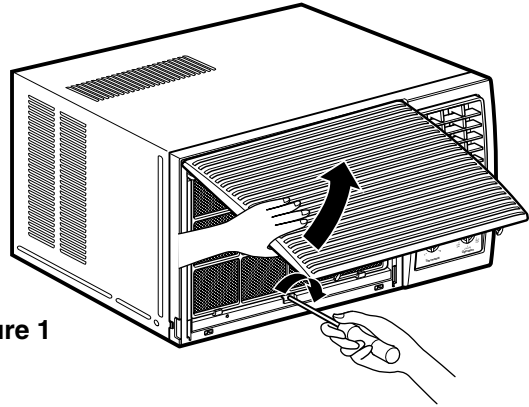

Figure 1

2.1.2 CABINET

1. After disassembling the FRONT GRILLE, remove the 2 screws which fasten the cabinet at both sides.
2. Remove the 2 screws which fasten the cabinet at back.
3. Pull the base pan forward. (See Figure 2)
4. Remove the cabinet.
5. Re-install the component by referring to the removal procedure, above.

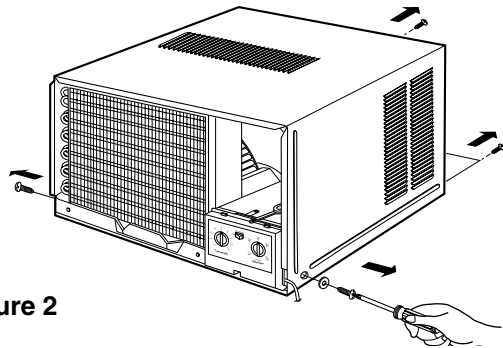

Figure 2

2.1.3 CONTROL BOX

1. Remove the front grille. (Refer to section 2.1.1)
2. Remove the cabinet. (Refer to section 2.1.2)
3. Remove the 2 screws which fasten the control box cover.
4. Remove two housings which connect compressor wire and motor wire in the control box.
5. Discharge the capacitor by placing a 20,000 ohm resistor across the capacitor terminals.
6. Remove the 2 screws which fasten the control box.
7. Pull the control box forward completely.
8. Re-install the components by referring to the removal procedure, above. (See Figure 3)
(Refer to the circuit diagram found on page 24 in this manual and on the control box.)

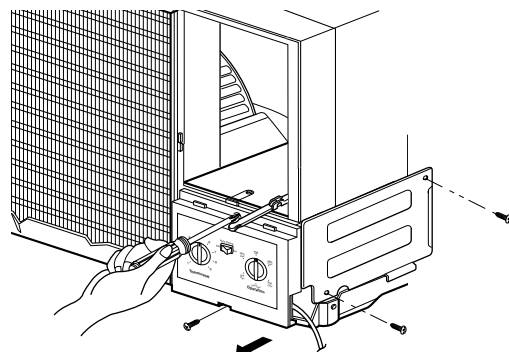

Figure 3

2.2 AIR HANDLING PARTS

2.2.1 AIR GUIDE AND BLOWER

1. Remove the front grille. (Refer to section 2.1.1)
2. Remove the cabinet. (Refer to section 2.1.2)
3. Remove the control box. (Refer to section 2.1.3)
4. Remove the 4 screws which fasten the brace.
5. Remove the brace.
6. Remove the 2 screws which fasten the evaporator.
7. Move the evaporator forward and pulling it upward slightly. (See Figure 4)
8. Move the evaporator to the left carefully.
9. Remove the 2 terminals carefully. (See Figure 5, at Electric heater Model)
10. Remove the 3 screws which fasten the Heater Cover. (See Figure 5, at Electric Heater Model)
11. Remove the Heater cover. (See Figure 5, at Electric Heater Model)
12. Pull out the hook of orifice by pushing the tabs and remove it. (See Figure 6)
13. Remove the clamp with a hand plier which secures the blower.
14. Remove the blower.
15. Remove the 4 screws which fasten the air guide from the barrier.
16. Move the air guide backward, pulling out from the base pan.
17. Re-install the components by referring to the removal procedure, above.

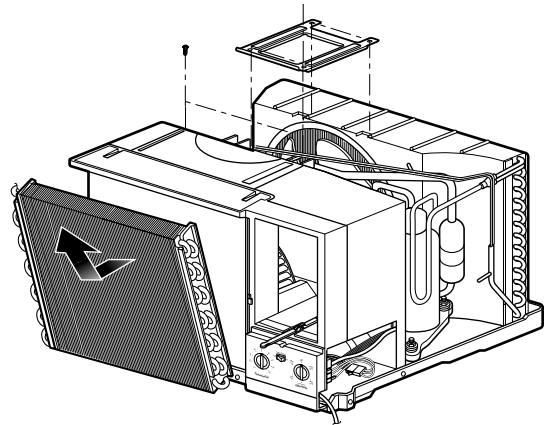

Figure 4

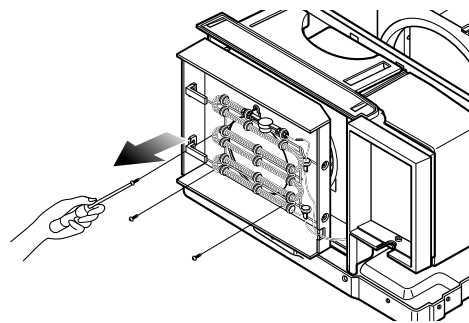

Figure 5

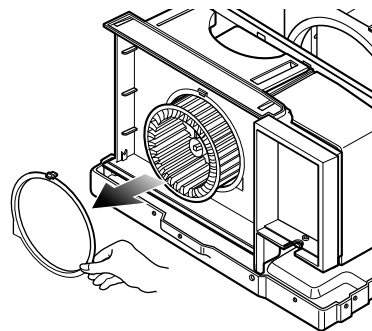

Figure 6

2.2.2 FAN

1. Remove the cabinet. (Refer to section 2.1.2)
2. Remove the brace (Refer to section 2.2.1)
3. Remove the 4 screws which fasten the condenser.
4. Move the condenser to the left carefully.
5. Remove the clamp which secures the fan.
6. Remove the fan. (See Figure 7)
7. Re-install by referring to the removal procedure.

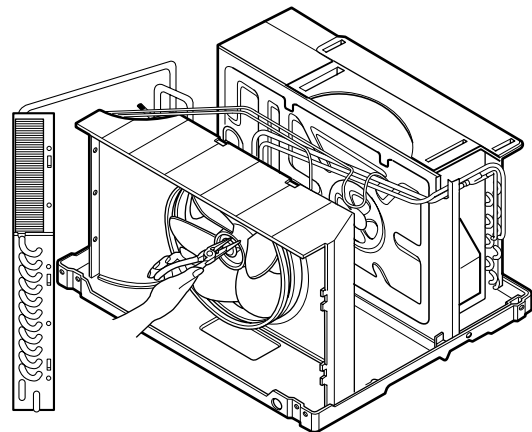

Figure 7

2.2.3 SHROUD

1. Remove the fan. (Refer to section 2.2.2)
2. Remove the screw which fastens the shroud.
3. Remove the shroud. (See Figure 8)
4. Re-install the component by referring to the removal procedure, above.

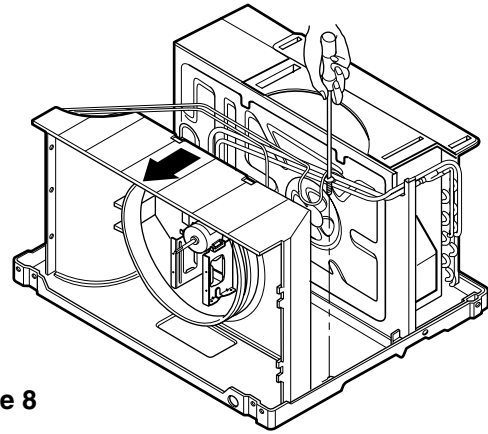

Figure 8

2.3 ELECTRICAL PARTS

2.3.1 OVERLOAD PROTECTOR

1. Remove the cabinet. (Refer to section 2.1.2)
2. Remove the nut which fastens the terminal cover.
3. Remove the terminal cover. (See Figure 9)
4. Remove all the leads from the overload protector.
5. Remove the overload protector.
6. Re-install the component by referring to the removal procedure, above.

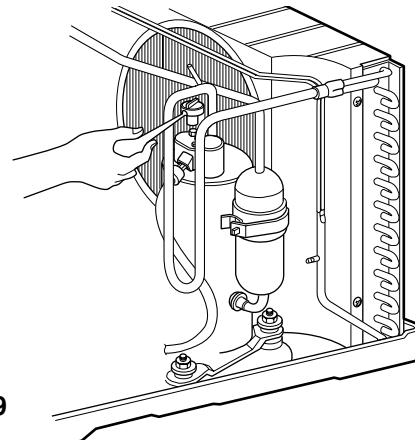

Figure 9

2.3.2 COMPRESSOR

1. Remove the cabinet. (Refer to section 2.1.2)
2. Discharge the refrigerant system using a Freon™ Recovery System.
If there is no valve to attach the recovery system, install one (such as a WATCO A-1) before venting the Freon™. Leave the valve in place after servicing the system.
3. Remove the overload protector. (Refer to section 2.3.1)
4. After purging the unit completely, unbraid the suction and discharge tubes at the compressor connections.
5. Remove the 3 nuts and the 3 washers which fasten the compressor.
6. Remove the compressor. (See Figure 10)
7. Re-install the components by referring to the removal procedure, above.

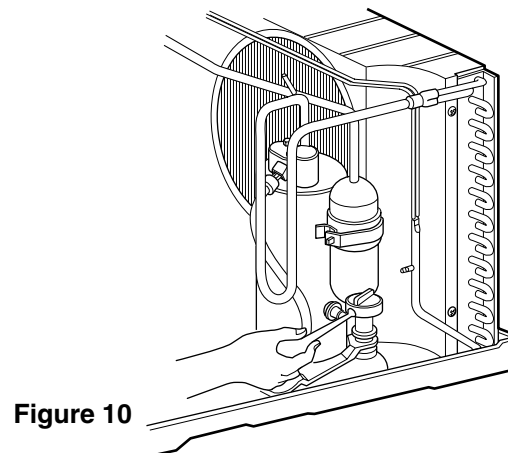

Figure 10

2.3.3 CAPACITOR

1. Remove the control box. (Refer to section 2.1.3)
2. Remove the knobs and the screw which fasten control panel from control box.
3. Remove the screw which located in the front.
4. Open the bottom side of control box.
5. Remove the screw and the clamp which fastens the capacitor.
6. Disconnect all the leads of capacitor terminals.
7. Re-install the components by referring to the removal procedure, above. (See Figure 11)

2.3.4 POWER CORD

1. Remove the control box. (Refer to section 2.1.3)
2. Open the control box. (Refer to section 2.3.3)
3. Disconnect the grounding screw from the control box.
4. Disconnect the 2 receptacles.
5. Remove a screw which fastens the clip cord. (See Figure 12)
6. Remove the power cord.
7. Re-install the component by referring to the above removal procedure, above. (Use only one ground-marked hole \oplus for ground connection.)
8. If the supply cord of this appliance is damaged, it must be replaced by the special cord. (The special cord means the cord which has the same specification marked on the supply cord attached at the unit.)

2.3.5 THERMOSTAT

1. Remove the control box. (Refer to section 2.1.3)
2. Open the control box. (Refer to section 2.3.3)
3. Remove the 2 screws which fasten the thermostat.
4. Disconnect 2 leads of thermostat terminals.
5. Remove the thermostat.
6. Re-install the components by refereing to the above removal procedure. (See Figure 13)

2.3.6 ROTARY SWITCH

1. Remove the control box. (Refer to section 2.1.3)
2. Open the control box. (Refer to section 2.3.3)
3. Remove the 2 screws which fasten the rotary switch.
4. Disconnect all the leads of the rotary switch terminals.
5. Remove the rotary switch.
6. Re-install the components by referring to the above removal procedure. (See Figure 14)

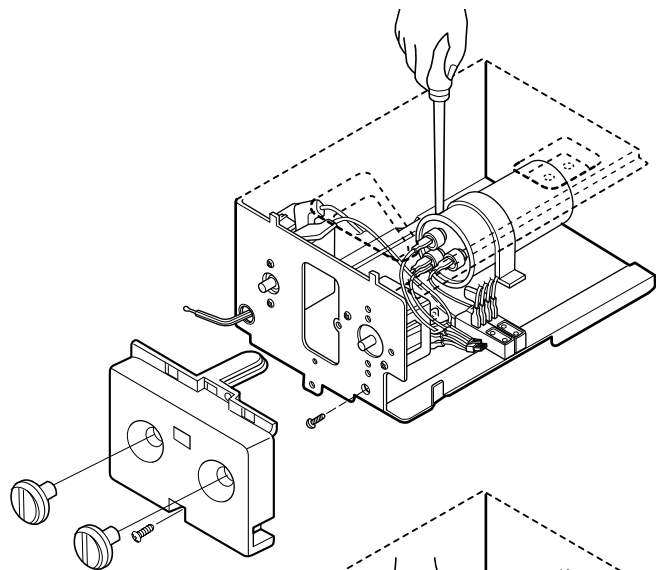

Figure 11

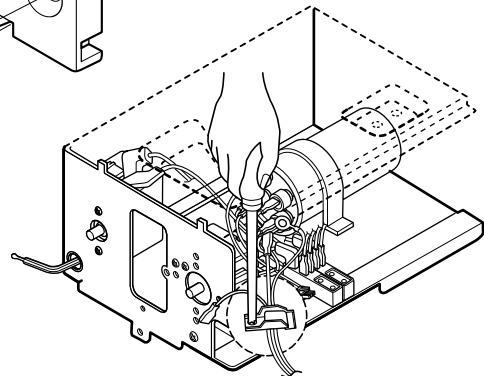

Figure 12

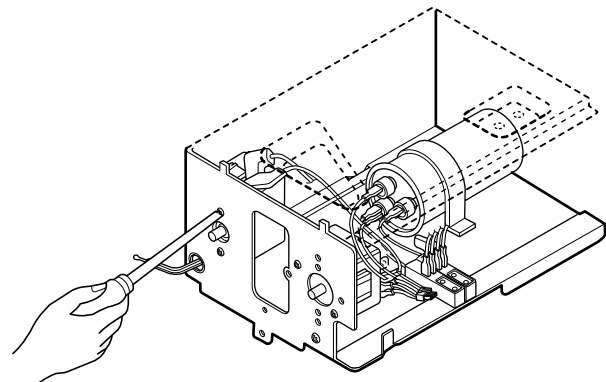

Figure 13

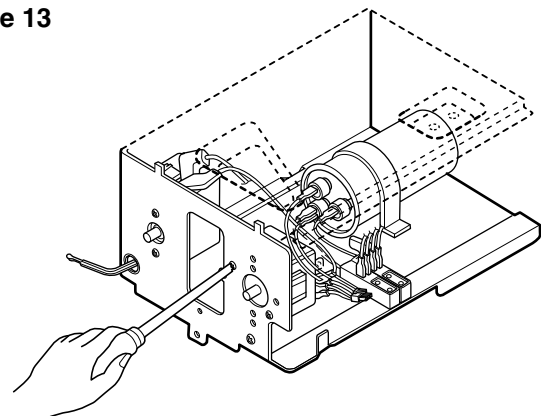

Figure 14

2.3.7 MOTOR

1. Remove the cabinet. (Refer to section 2.1.2)
2. Remove the evaporator. (Refer to section 2.2.1)
3. Remove the orifice. (Refer to section 2.2.1)
4. Remove the blower. (Refer to section 2.2.1)
5. Remove the fan. (Refer to section 2.2.2)
6. Remove the control box cover and disconnect 5 or 4 wires of motor housing. (Refer to section 2.1.3)
7. Remove the 2 or 4 screws which fasten the motor from the mount motor. (See Figure 15)
8. Remove the motor.
9. Re-install the components by referring to the removal procedure, above.(See Figure 15)

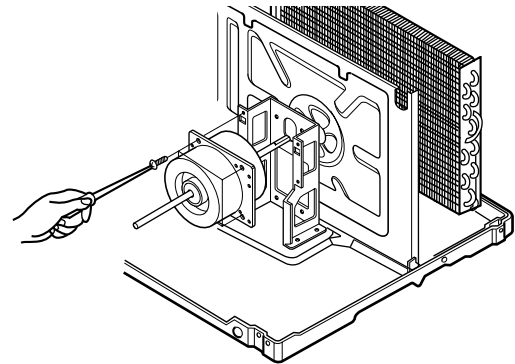

Figure 15

CAUTION

Discharge the refrigerant system using a Freon™ Recovery System.
If there is no valve to attach the recovery system, install one (such as a WATCO A-1) before venting the Freon™. Leave the valve in place after servicing the system.

2.4.1 CONDENSER

1. Remove the cabinet. (Refer to section 2.1.2)
2. Remove the 4 screws which fasten the brace.(Refer to section 2.2.1)
3. Remove the 5 screws which fasten the condenser and shroud.
4. After discharging the refrigerant completely, unbraid the interconnecting tube at the condenser connections.
5. Remove the condenser.
6. Re-install the component by referring to notes. (See Figure 16)

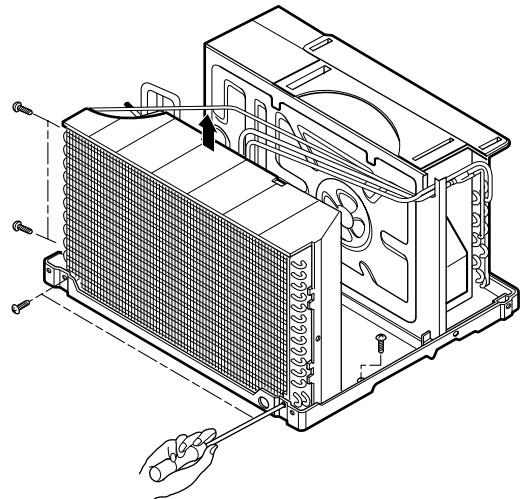

Figure 16

2.4.2 EVAPORATOR

1. Remove the cabinet. (Refer to section 2.1.2)
2. Remove the 2 screws which fasten the evaporator.
3. Move the evaporator sideways carefully. (Refer to section 2.2.1)
4. After discharging the refrigerant completely, unbraid the interconnecting tube at the evaporator connections.
5. Remove the evaporator.
6. Re-install the component by referring to notes. (See Figure 17)

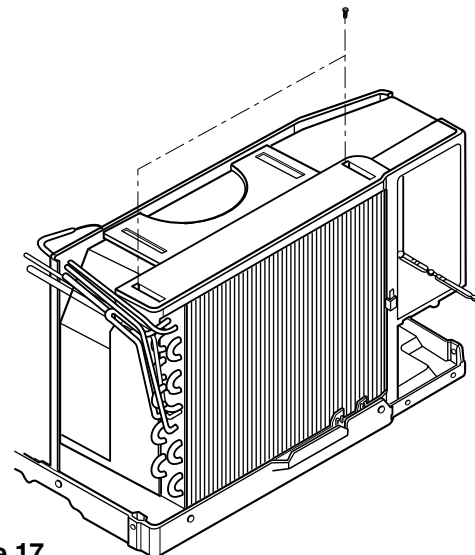

Figure 17

2.4.3 CAPILLARY TUBE

1. Remove the cabinet. (Refer to section 2.1.2)
2. After discharging the refrigerant completely, unbraid the interconnecting tube at the capillary tube. (See caution above)

3. Remove the capillary tube.
4. Re-install the component by referring to notes.

NOTES

— Replacement of the refrigeration cycle.

1. When replacing the refrigeration cycle, be sure to Discharge the refrigerant system using a Freon™ recovery System.
If there is no valve to attach the recovery system, install one (such as a WATCO A-1) before venting the Freon™. Leave the valve in place after servicing the system.
2. After discharging the unit completely, remove the desired component, and unbraid the pinch-off tubes.
3. Solder service valves into the pinch-off tube ports, leaving the valves open.
4. Solder the pinch-off tubes with Service valves.
5. Evacuate as follows.
 - 1) Connect the vacuum pump, as illustrated figure 18A.
 - 2) Start the vacuum pump, slowly open manifold valves A and B with two full turns counterclockwise and leave the valves open. The vacuum pump is now pulling through valves A and B up to valve C by means of the manifold and entire system.

CAUTION

If high vacuum equipment is used, just crack valves A and B for a few minutes, then open slowly with the two full turns counterclockwise. This will keep oil from foaming and being drawn into the vacuum pump.

- 3) Operate the vacuum pump for 20 to 30 minutes, until 600 microns of vacuum is obtained. Close valves A and B, and observe vacuum gauge for a few minutes. A rise in pressure would indicate a possible leak or moisture remaining in the system. With valves A and B closed, stop the vacuum pump.
- 4) Remove the hose from the vacuum pump and place it on the charging cylinder. See figure 18B.
Open valve C.
Discharge the line at the manifold connection.
- 5) The system is now ready for final charging.

6. Recharge as follows :

- 1) Refrigeration cycle systems are charged from the High-side. If the total charge cannot be put in the High-side, the balance will be put in the suction line through the access valve which you installed as the system was opened.
- 2) Connect the charging cylinder as shown in figure 18B.
With valve C open, discharge the hose at the manifold connection.
- 3) Open valve A and allow the proper charge to enter the system. Valve B is still closed.
- 4) If more charge is required, the high-side will not take it. Close valve A.
- 5) With the unit running, open valve B and add the balance of the charge.
 - a. Do not add the liquid refrigerant to the Low-side.
 - b. Watch the Low-side gauge; allow pressure to rise to 30 lbs.
 - c. Turn off valve B and allow pressure to drop.
 - d. Repeat steps b. and c. until the balance of the charge is in the system.
- 6) When satisfied the unit is operating correctly, use the pinch-off tool with the unit still running and clamp on to the pinch-off tube. Using a tube cutter, cut the pinch-off tube about 2 inches from the pinch-off tool. Use sil-fos solder and solder pinch-off tube closed. Turn off the unit, allow it to set for a while, and then test the leakage of the pinch-off connection.

Equipment needed: Vacuum pump, Charging cylinder, Manifold gauge, Brazing equipment. Pin-off tool capable of making a vapor-proof seal, Leak detector, Tubing cutter, Hand Tools to remove components, Service valve.

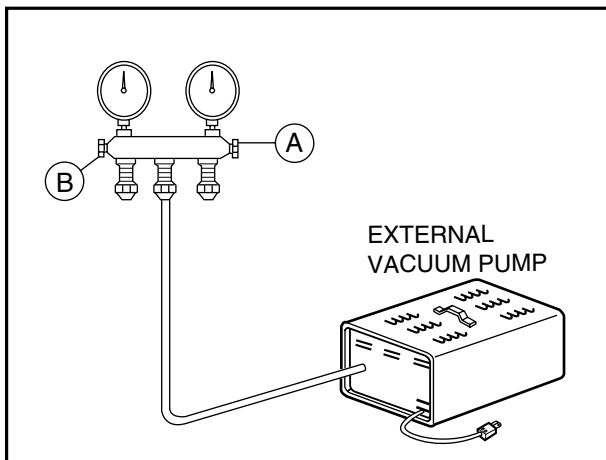
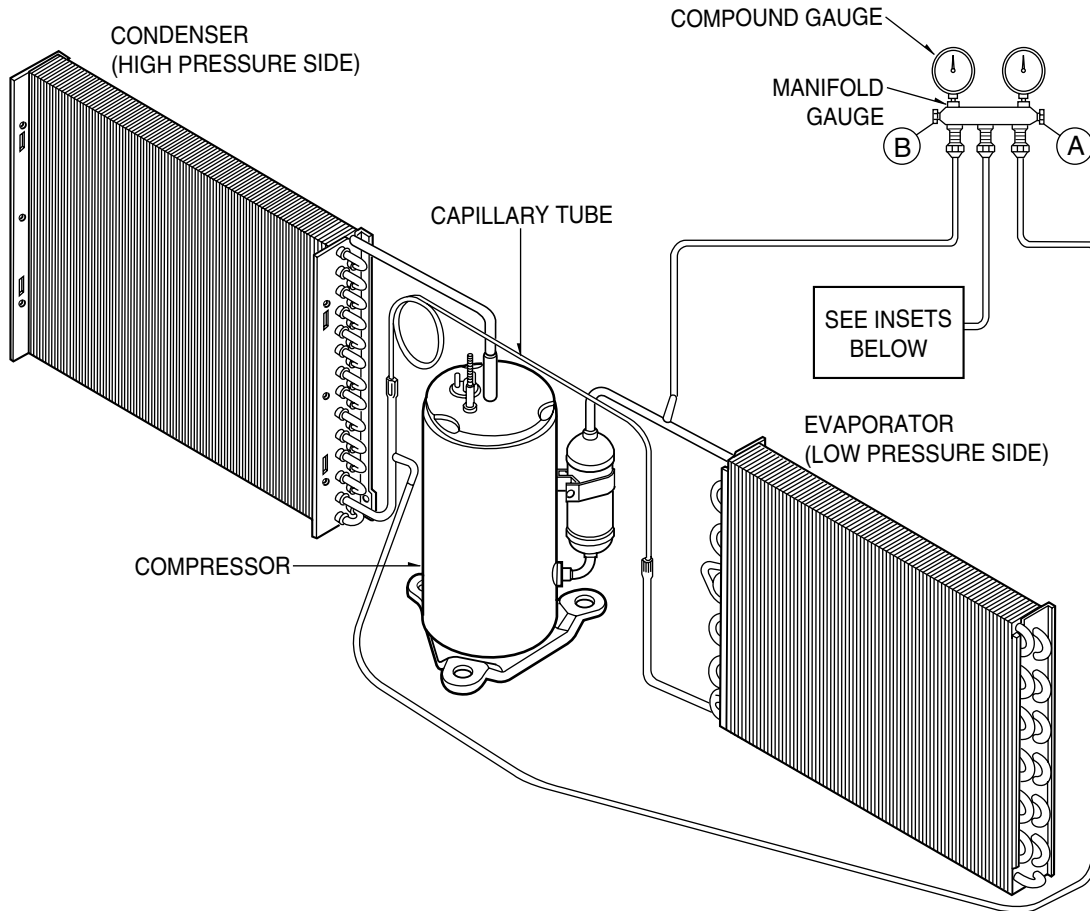

Figure 18A-Pulling Vacuum

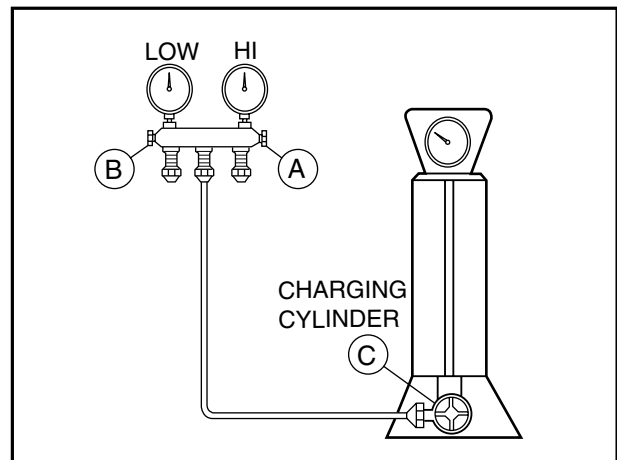

Figure 18B-Charging

3. INSTALLATION

3.1 SELECT THE BEST LOCATION

1. To prevent vibration and noise, make sure the unit is installed securely and firmly.
2. Install the unit where the sunlight does not shine directly on the unit.
3. The outside of the cabinet must extend outward for at least 12" and there should be no obstacles, such as a fence or wall, within 20" from the back of the cabinet because it will prevent heat radiation of the condenser.
Restriction of outside air will greatly reduce the cooling efficiency of the air conditioner.

CAUTION

All side louvers of the cabinet must remain exposed to the outside of the structure.

4. Install the unit a little slanted so the back is slightly lower than the front (about 1/2"). This will help force condensed water to the outside.
5. Install the unit from the bottom about 30"~60" above the floor level.

3.2 CHECK OF INSTALLATION

The setting conditions must be checked prior to initial starting.

The undermentioned items are especially important checking points when the installation is finished.

1. Grounding wire (Green or Green and Yellow) is provided in the power cord. The green wire must be grounded.
2. Connect to a single-outlet 15A circuit.
(or 20A circuit for Electric Heater Model)
3. To avoid vibration or noise, make sure the air conditioner is installed securely.
4. Avoid placing furniture or draperies in front of the air inlet and outlet.

3.3. HOW TO DRAIN (When using drain pipe)

The air conditioner must be installed horizontally or tilted slightly to the outside for proper water drainage.

On exceptionally hot and humid days the air conditioner may overflow condensed water.

If the air conditioner is used in hot and a high humidity zone, exchange the ① HOLE RUBBER for the ② DRAIN PIPE. (See figure 20, figure 21.)

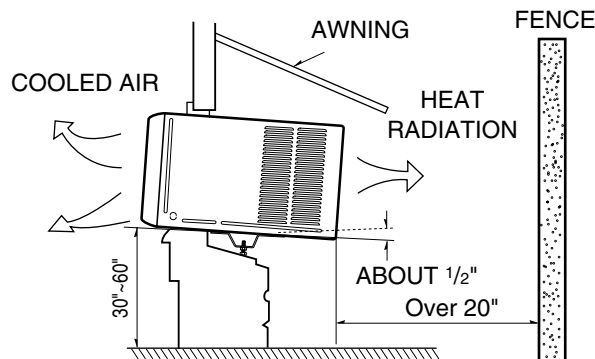

Figure 19

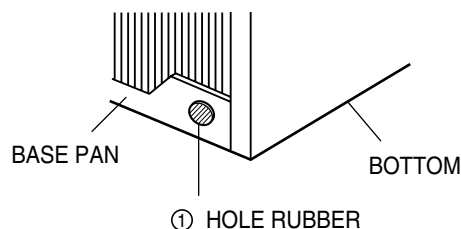

Figure 20

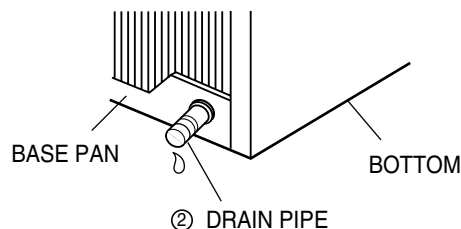
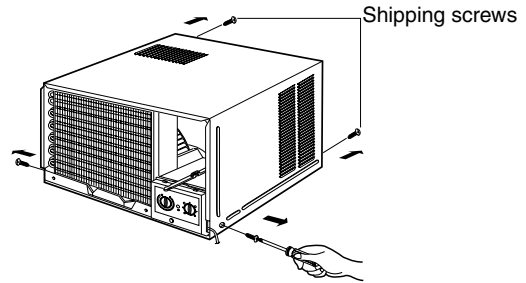

Figure 21

3.4-1 HOW TO INSTALL(Installation kit not included models)

1. Remove the screws which fasten the cabinet at both sides and at the back.



2. Slide the unit from the cabinet by gripping the base pan handle and pulling forward while bracing the cabinet.

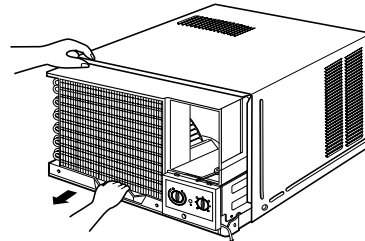

3. Remove EPS Material.

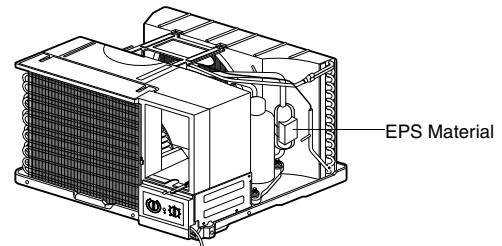

4. Slide the unit into the cabinet.

CAUTION: For security purpose, reinstall screw at cabinet's sides.

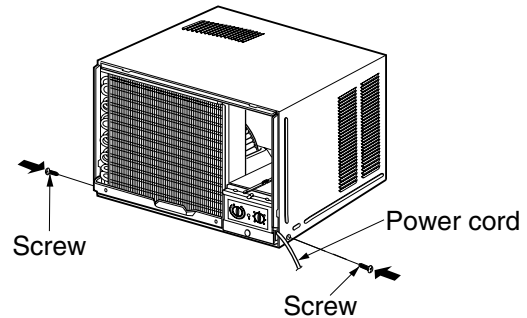

5. Attach the front grille to the cabinet by inserting the tabs on the grille into the tabs on the front of the cabinet. Push the grille in until it snaps into place.

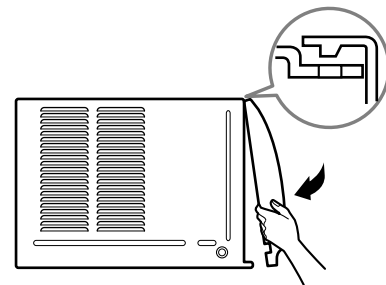

6. Lift the inlet grille and secure it with a screw through the front grille.

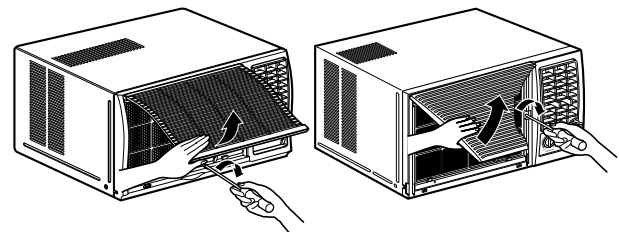

3.4-2 HOW TO INSTALL (Installation kit included models)

3.4.1 WHEN USING GASKET

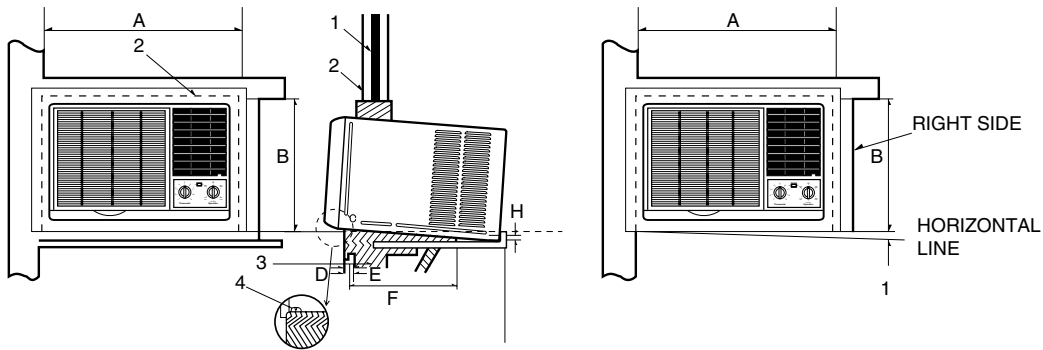

1. WINDOW (WIDTH-A, HEIGHT-B)
2. GASKET
3. WALL

4. DETAILS 5.1 x 30 ROUND HEAD WOOD SCREWS

A	B	C	D	E	F	H	I
625mm (24 ⁵ / ₈ ")	392mm (15 ⁷ / ₁₆ ")	280mm (11 ¹ / ₃₂ ")	30mm (1 ¹ / ₁₆ ")	0~25mm (0~1")	OVER 420mm (OVER 16 ¹⁷ / ₃₂ ")	5~10mm (³ / ₁₆ "~ ³ / ₈ ")	-5~5mm (- ³ / ₁₆ "~ ³ / ₁₆ ")

3.4.2 WHEN USING INSTALLATION KITS

A. WINDOW REQUIREMENTS

This unit is designed for installation in standard double hung windows with actual opening widths from 27" to 39".

The top and bottom window sash must open sufficiently to allow a clear vertical opening of 16" from the bottom of the upper sash to the window stool.

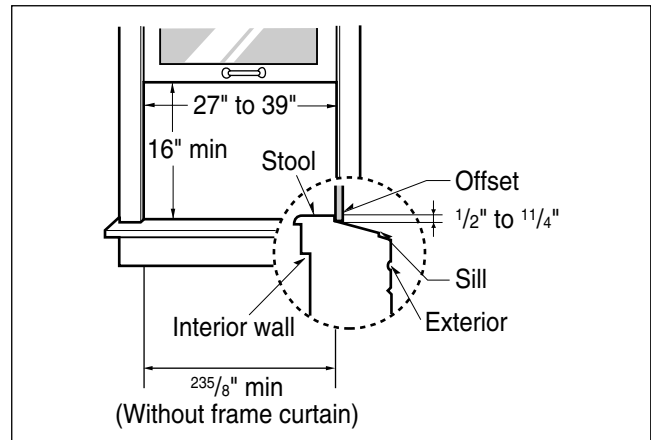

B. INSTALLATION KITS CONTENTS

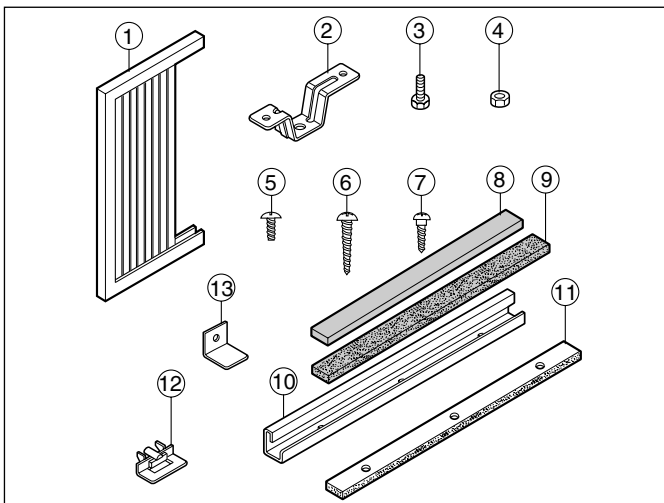

NO.	NAME OF PARTS	Q'TY
1	FRAME CURTAIN	2
2	SILL SUPPORT	2
3	BOLT	2
4	NUT	2
5	SCREW(TYPE A)	16
6	SCREW(TYPE B)	3
7	SCREW(TYPE C)	5
8	FOAM-STRIP	1
9	FOAM-PE	1
10	UPPER GUIDE	1
11	FOAM-PE	1
12	FRAME GUIDE	2
13	WINDOW LOCKING BRACKET	1

3.5 SUGGESTED TOOL REQUIREMENTS

SCREWDRIVER(+, -), RULER, KNIFE, HAMMER, PENCIL, LEVEL

PREPARATION OF CHASSIS

1. Remove the screws which fasten the cabinet at both sides and at the back.
2. Slide the unit out from the cabinet by gripping the base pan handle and pulling forward while bracing the cabinet.
3. Remove EPS Material.
4. Cut the window sash seal to the proper length. Peel off the backing and attach the foam-pe ⑨ to the underside of the window sash.
5. Remove the backing from the top upper guide Foam PE ⑪ and attach it to the bottom of the upper guide ⑩.
6. Attach the upper guide onto the top of the cabinet with 3 type A screws.
7. Insert the frame guides ⑫ into the bottom of the cabinet.
8. Insert the Frame Curtain ① into the upper guide ⑩ and frame guides ⑫.
9. Fasten the curtains to the unit with 4 Type A screws at the both sides.

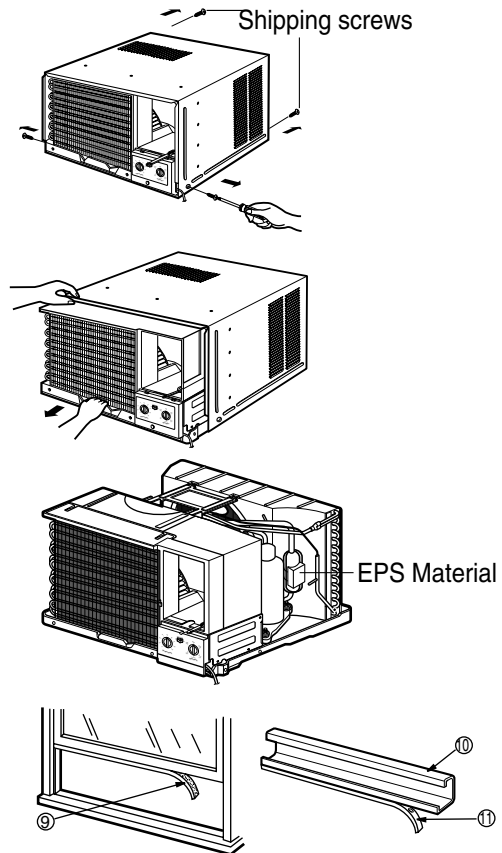

3.6 CABINET INSTALLATION

1. Open the window. Mark a line on center of the window stool(or desired air conditioner location). Carefully place the cabinet on the window stool and align the center mark on the bottom front with the center line marked in the window stool.
2. Pull the bottom window sash down behind the upper guide until it meets.

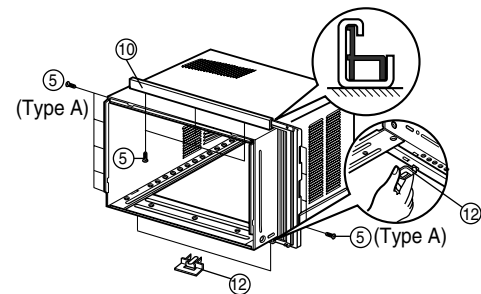

NOTE:

- Do not pull the window sash down so tightly that the movement of Frame Curtain is restricted.

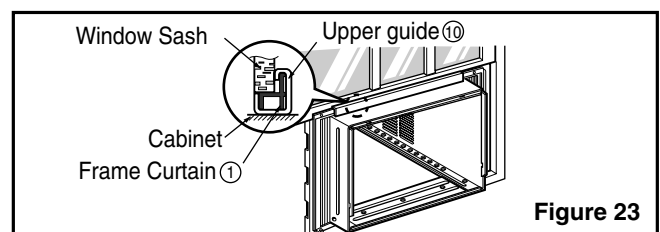
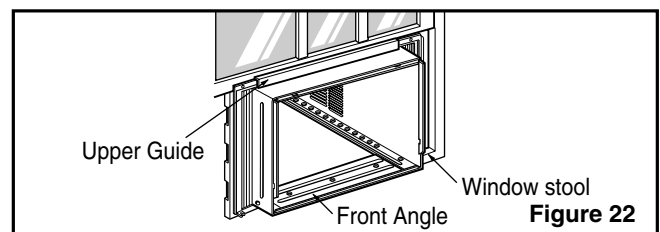

3. Loosely assemble the sill support using the parts in Figure 24.

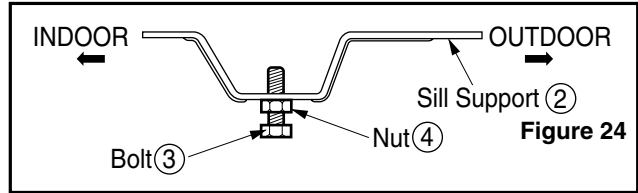

4. Select the position that will place the sill support near the outer most point on sill (See Figure 24)

NOTE: Be careful when you install the cabinet (frame guides 12 are broken easily).

5. Attach the sill support to the cabinet track hole in relation to the selected position using 2 Type A screws in each support (See Figure 25).

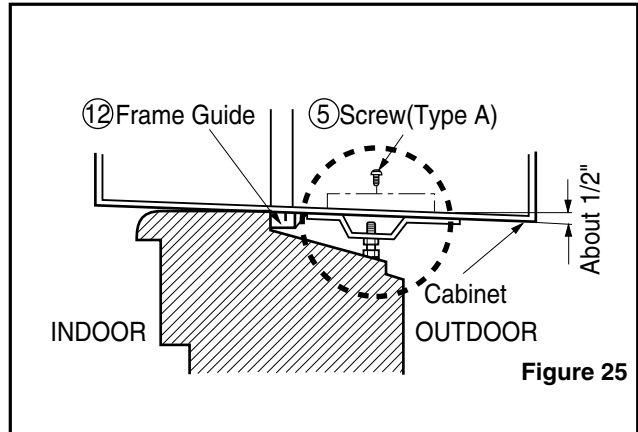

6. The cabinet should be installed with a very **slight tilt (about 1/2") downward** toward the outside (See Figure 26).
Adjust the bolt and the nut of sill support for balancing the cabinet.

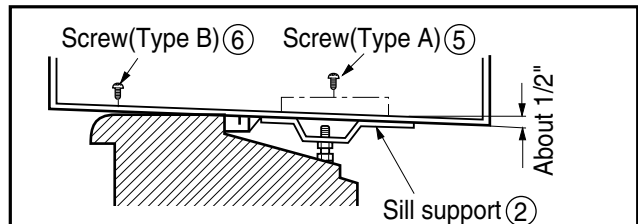

7. Attach the cabinet to the window stool by driving the screws 6 (Type B: Length sixteen millimeters and below.) through the front angle into window stool (5/8").

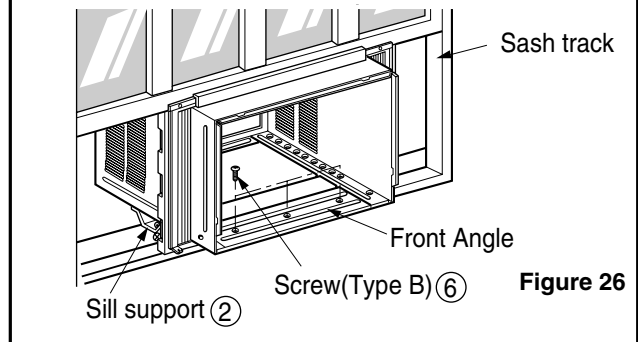

8. Pull each Frame curtain properly to each window sash track, and repeat step 2.

9. Attach each Frame curtain to the window sash by using screws 7 (Type C). (See Figure 27)

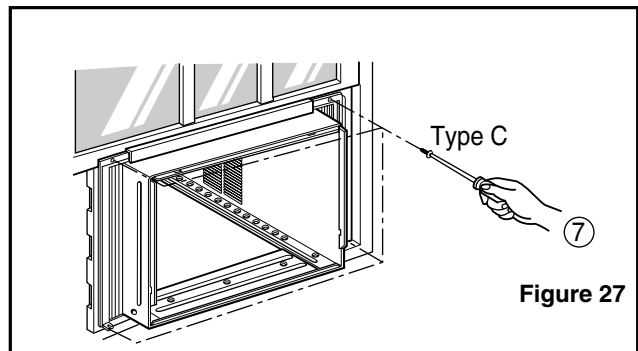

10. Slide the unit into the cabinet.(See Fig. 28)

CAUTION: For security purpose, reinstall screws(Type A) at the cabinet's sides.

11. Cut the foam-strip ⑧ to the proper length and insert between the upper and lower window sash.
(See Fig. 29)

12. Attach the window locking bracket ⑬ with a type C screw. (See Fig. 30)

13. Attach the front grille to the cabinet by inserting the tabs on the grille into the tabs on the front of the cabinet. Push the grille in until it snaps into place.(See Fig. 31)

14. Lift the inlet grille and secure it with a type A screw through the front grille.(See Fig. 32)

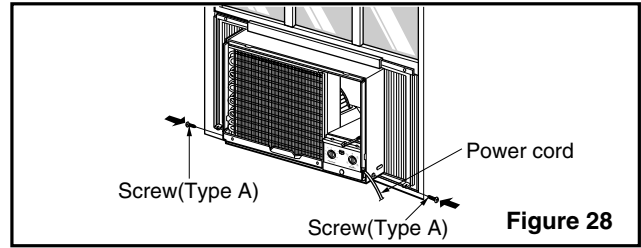

Figure 28

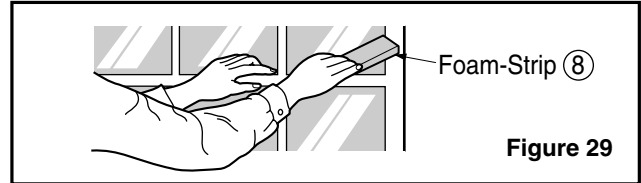

Figure 29

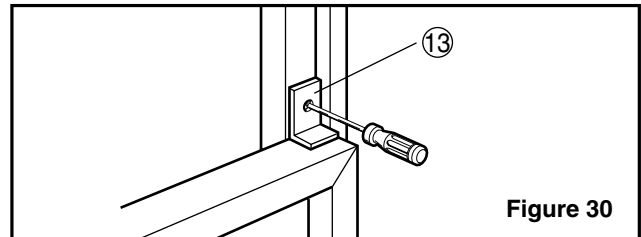

Figure 30

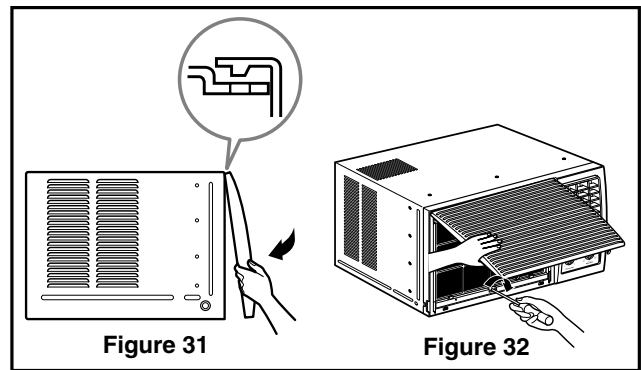

Figure 31

Figure 32

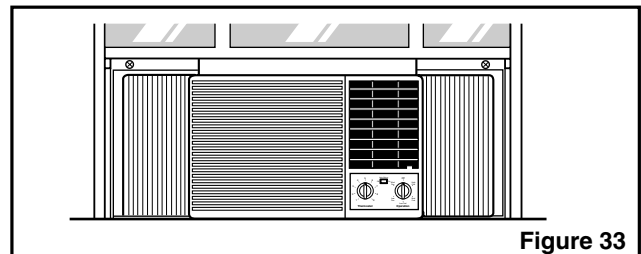
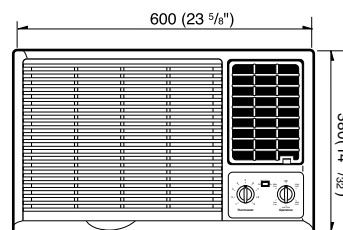
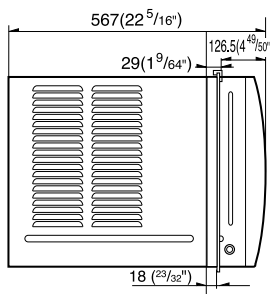

Figure 33

4. TROUBLESHOOTING GUIDE

4.1 OUTSIDE DIMENSIONS

unit: mm(inch)



4.2 PIPING SYSTEM

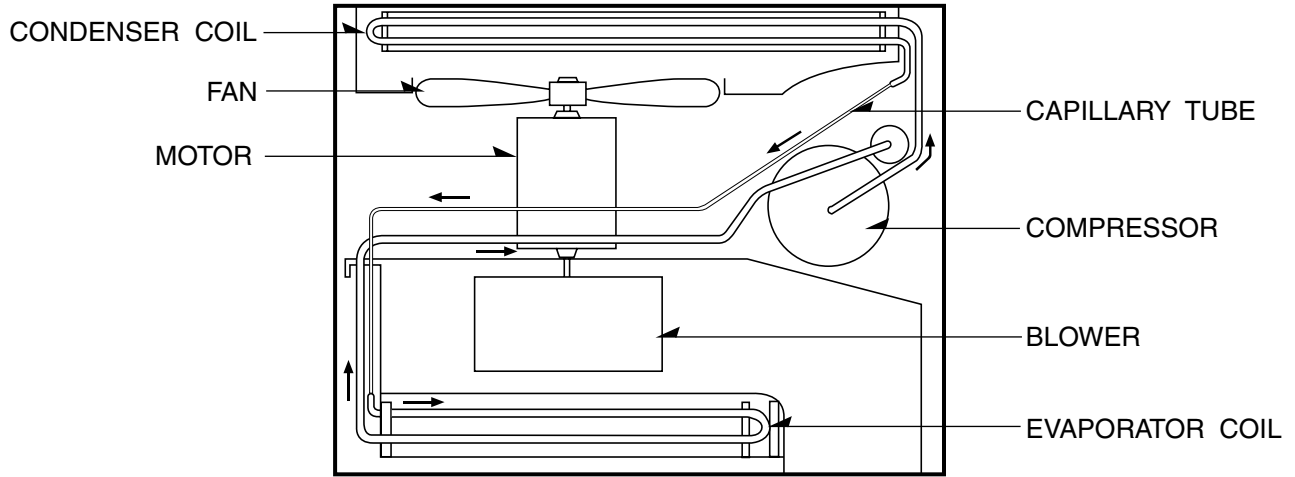
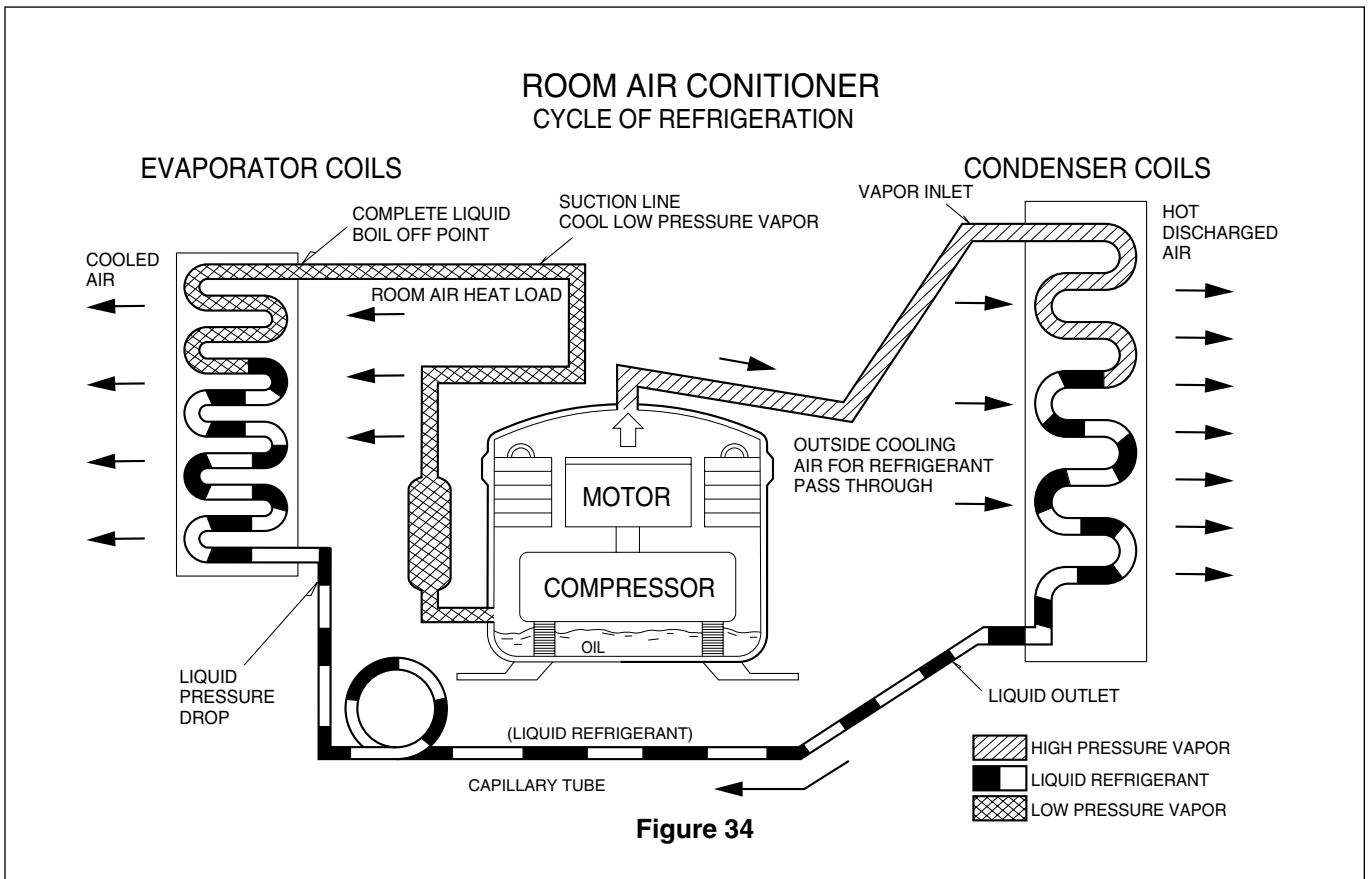

Figure 34 is a brief description of the important components and their function in what is called the refrigeration system. This will help you to understand the refrigeration cycle and the flow of the refrigerant in the cooling cycle.



4.3 TROUBLESHOOTING GUIDE

In general, possible trouble is classified in two kinds.

The one is called Starting Failure which is caused from an electrical defect, and the other is ineffective Air Conditioning caused by a defect in the refrigeration circuit and improper application.

Unit runs but poor cooling.

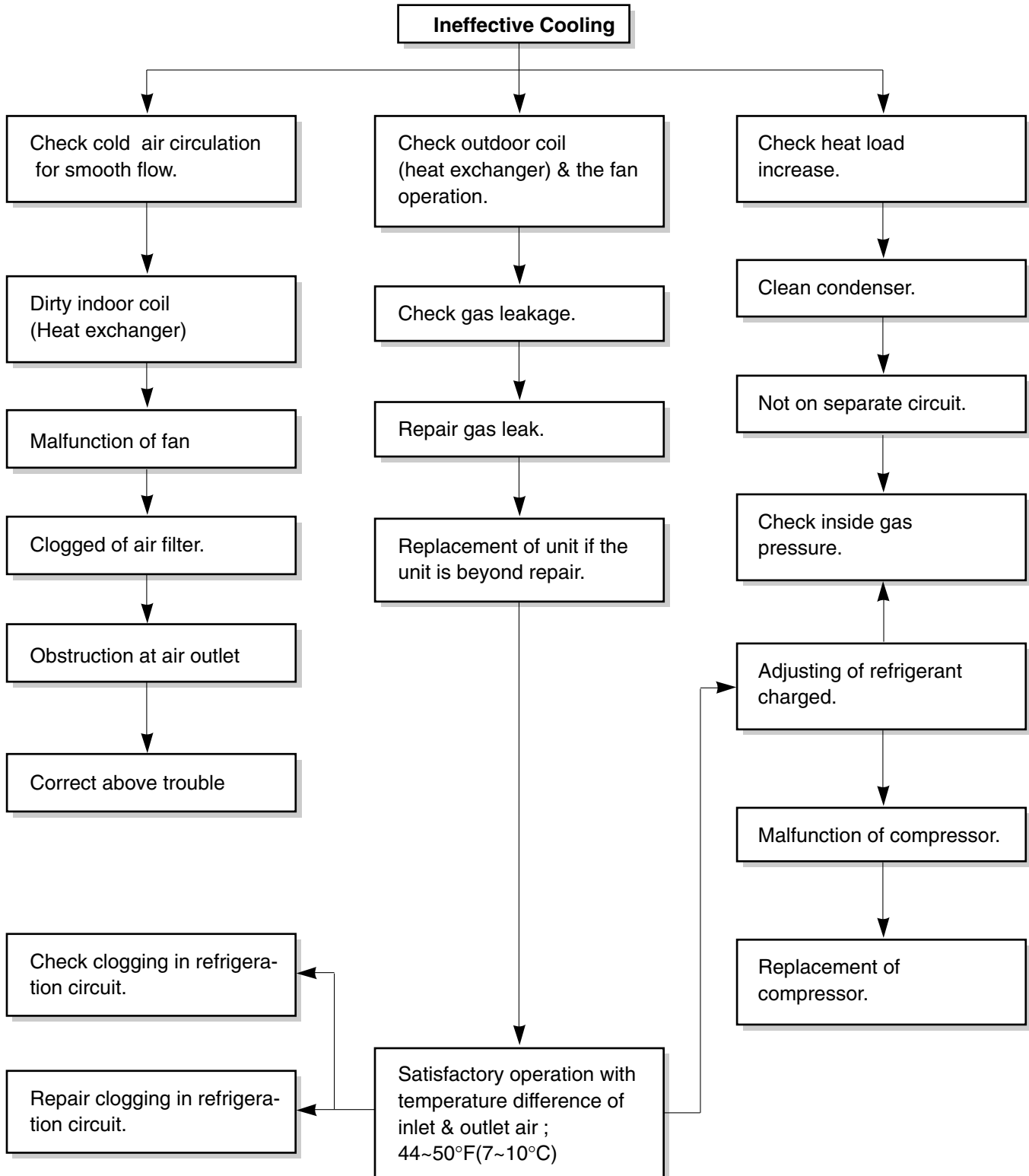

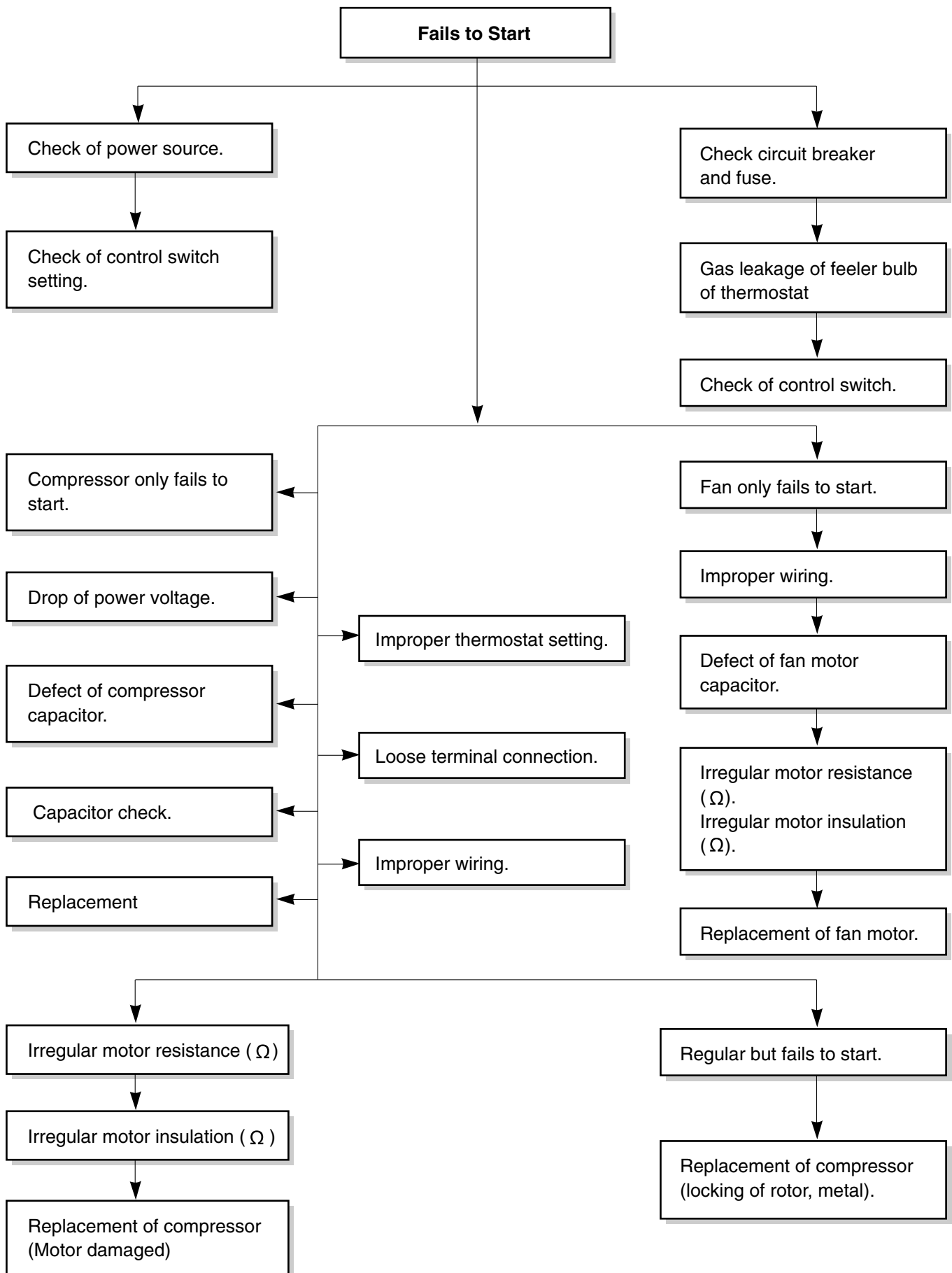

ROOM AIR CONDITIONER VOLTAGE LIMITS

NAME PLATE RATING	MINIMUM	MAXIMUM
208~230±10%	187V	253V
115±10%	104V	126V

COMPLAINT	CAUSE	REMEDY
Fan motor will not run.	No power	Check voltage at outlet. Correct if none.
	Power supply cord	Check voltage to rotary switch. If none, check power supply cord. Replace cord if circuit is open.
	Rotary switch	Check switch continuity. Refer to wiring diagram for terminal identification. Replace switch if defective.
	Wire disconnected or connection loose	Connect wire. Refer to wiring diagram for terminal identification. Repair or replace loose terminal.
	Capacitor (Discharge capacitor before testing.)	Test capacitor. Replace if not within ±10% of manufacturer's rating. Replace if shorted, open, or damaged.
	Will not rotate	Fan blade hitting shroud or blower wheel hitting scroll. Realign assembly. Units using slinger ring for condenser fan must have $\frac{1}{4}$ to $\frac{5}{16}$ inch clearance to the base. If it hits the base, shim up the bottom of the fan motor with mounting screw(s). Check fan motor bearings; if motor shaft will not rotate, replace the motor.
Fan motor runs intermittently	Revolves on overload.	Check voltage. If not within limits, call an electrician. Test capacitor. Check bearings. Does the fan blade rotate freely? If not, replace fan motor. Pay attention to any change from high speed to low speed. If the speed does not change, replace the motor.
Fan motor noise.	Fan	If cracked, out of balance, or partially missing, replace it.
	Blower	If cracked, out of balance, or partially missing, replace it.
	Loose clamper	Tighten it.
	Worn bearings	If knocking sounds continue when running or loose, replace the motor. If the motor hums or noise appears to be internal while running, replace motor.
Compressor will not run, but fan motor runs.	Voltage	Check voltage. If not within limits, call an electrician.
	Wiring	Check the wire connections, if loose, repair or replace the terminal. If wires are off, refer to wiring diagram for identification, and replace. Check wire locations. If not per wiring diagram, correct.
	Rotary	Check for continuity, refer to the wiring diagram for terminal identification. Replace the switch if circuit is open.

COMPLAINT	CAUSE	REMEDY
Compressor will not run, but fan motor runs.	Thermostat	Check the position of knob. If not at the coldest setting, advance the knob to this setting and restart unit. Check continuity of the thermostat. Replace thermostat if circuit is open.
	Capacitor (Discharge capacitor before servicing.)	Check the capacitor. Replace if not within $\pm 10\%$ of manufacturer's rating. Replace if shorted, open, or damaged.
	Compressor	Check the compressor for open circuit or ground. If open or grounded, replace the compressor.
	Overload	Check the compressor overload, if externally mounted. Replace if open. (If the compressor temperature is high, remove the overload, cool it, and retest.)
Compressor cycles on overload.	Voltage	Check the voltage. If not within limits, call an electrician.
	Overload	Check overload, if externally mounted. Replace if open. (If the compressor temperature is high, remove the overload, cool, and retest.)
Compressor cycles on overload.	Fan motor	If not running, determine the cause. Replace if required.
	Condenser air flow restriction	Remove the cabinet. inspect the interior surface of the condenser; if restricted, clean carefully with a vacuum cleaner (do not damage fins) or brush. Clean the interior base before reassembling.
	Condenser fins (damaged)	If condenser fins are closed over a large area on the coil surface, head pressures will increase, causing the compressor to overload. Straighten the fins or replace the coil.
Compressor cycles on overload.	Capacitor	Test capacitor.
	Wiring	Check the terminals. If loose, repair or replace.
	Refrigerating system	Check the system for a restriction.
Insufficient cooling or heating	Air filter	If restricted, clean or replace.
	Exhaust damper door	Close if open.
	Unit undersized	Determine if the unit is properly sized for the area to be cooled.
Excessive noise	Blower or fan	Check the set screw or clamp. If loose or missing, correct. If the blower or fan is hitting air guide, rearrange the air handling parts.
	Copper tubing	Remove the cabinet carefully and rearrange tubing not to contact cabinet, compressor, shroud, and barrier.

5. SCHEMATIC DIAGRAM

5.1 CIRCUIT DIAGRAM

■ COOLING ONLY MODEL

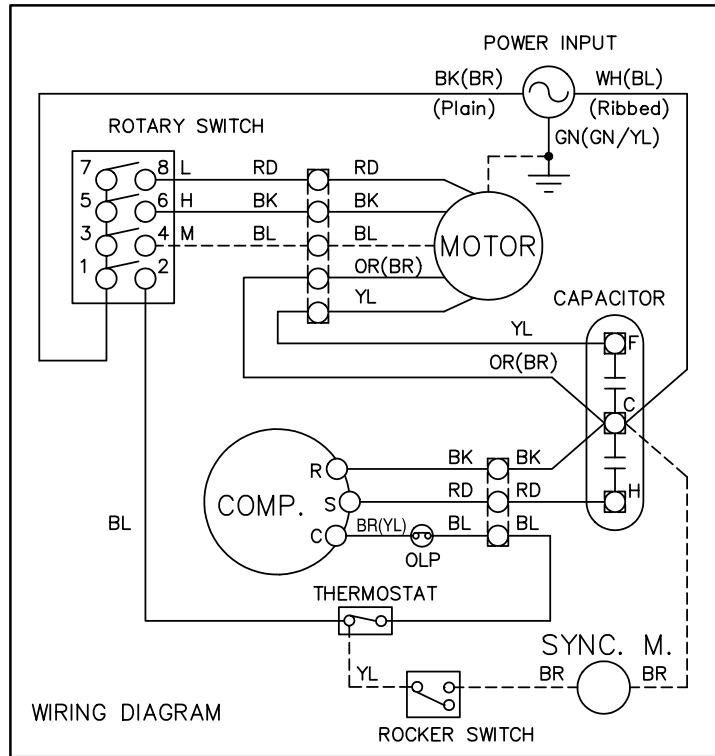

■ ELECTRIC HEATING MODEL

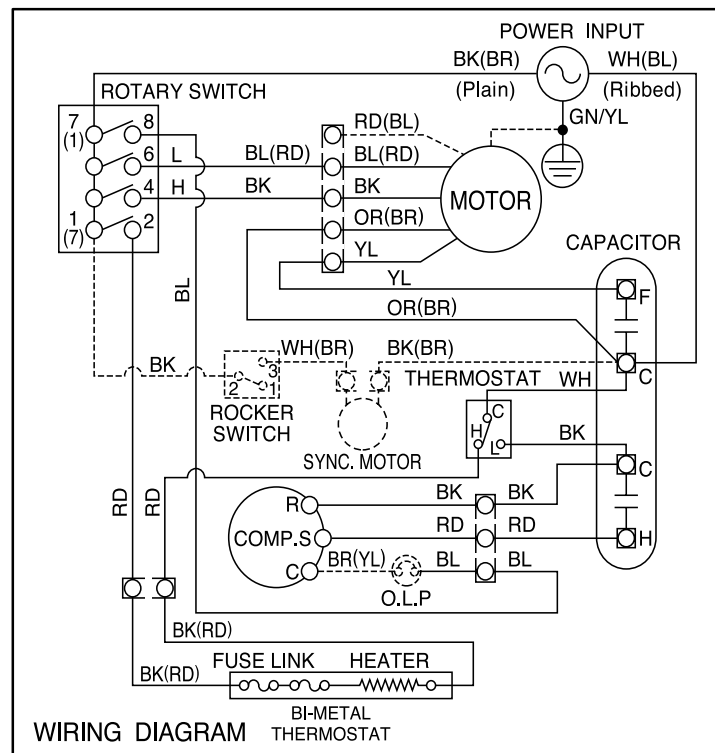

6. EXPLODED VIEW

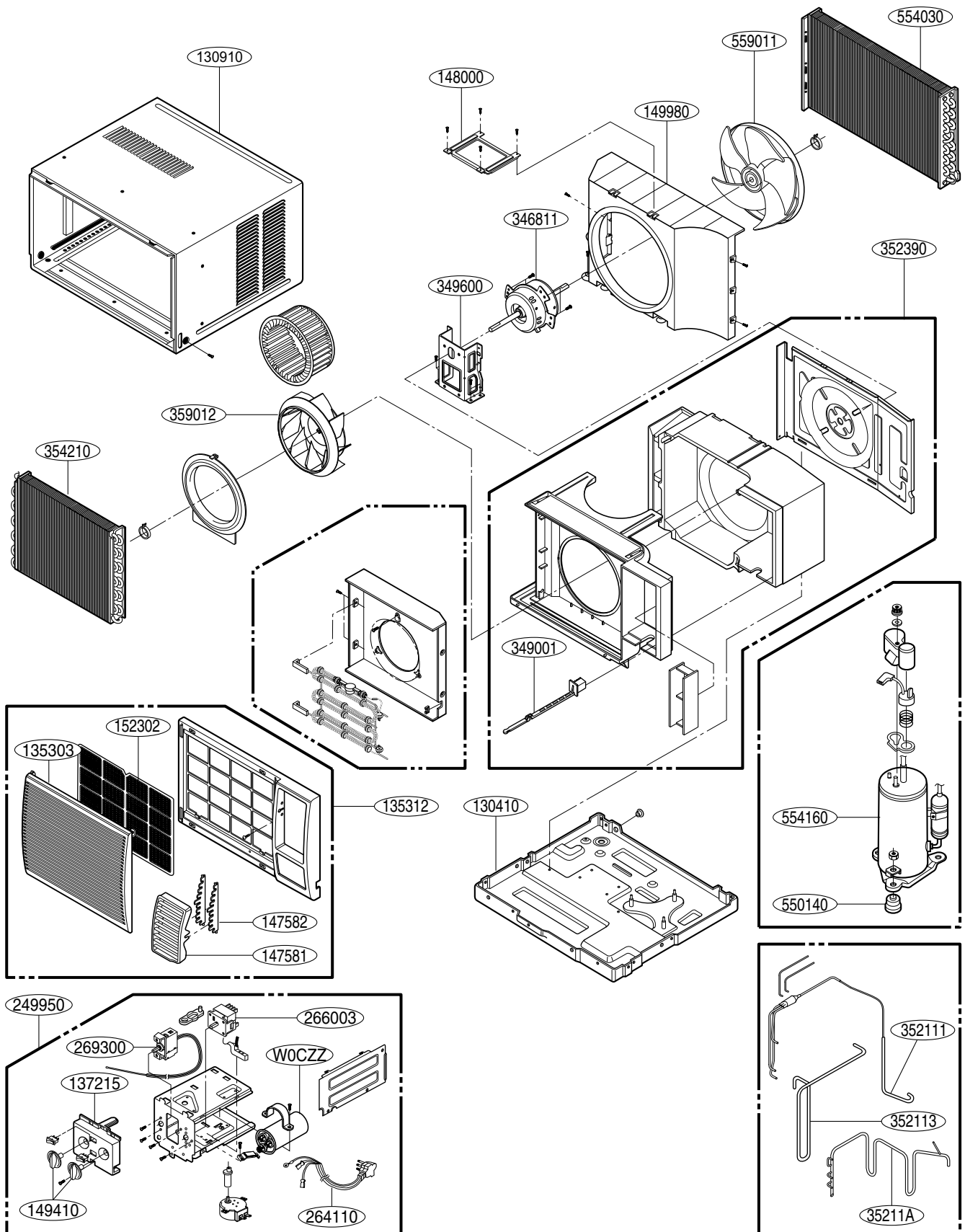



P/NO : 3828A20140J

FEBRUARY, 2008