

Service Manual

Room Air Conditioner

CW-XC183HU

CW-XC243HU

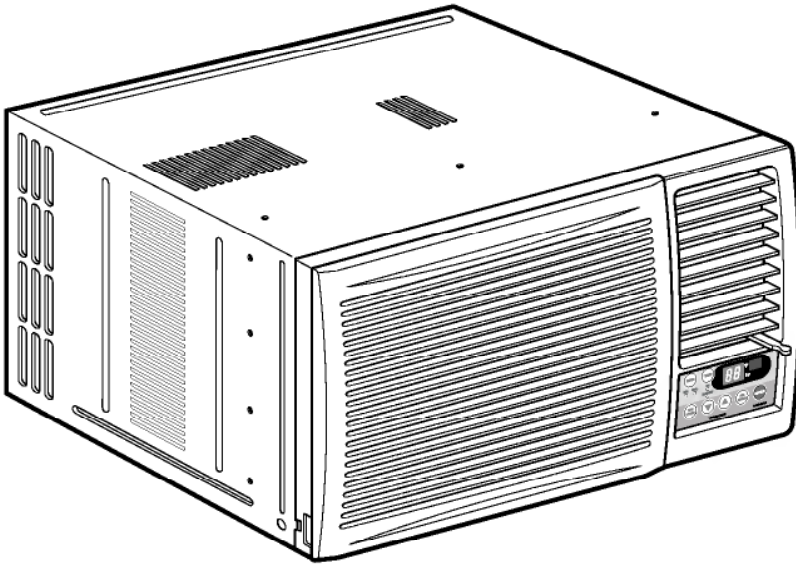

⚠ WARNING

This service information is designed for experienced repair technicians only and is not designed for use by the general public. It does not contain warnings or cautions to advise non-technical individuals of potential dangers in attempting to service a product. Products powered by electricity should be serviced or repaired only by experienced professional technicians. Any attempt to service or repair the product or products deal with in this service information by anyone else could result in serious injury or death.

Panasonic[®]

© 2003 Matsushita Electric Industrial co., Ltd.
All rights reserved. Unauthorized copying and
distribution is violation of law.

CONTENTS

1. PREFACE

1.1 SAFETY PRECAUTIONS.....	3
1.2 INSULATION RESISTANCE TEST.....	3
1.3 SPECIFICATIONS.....	3
1.4 FEATURES	4
1.5 CONTROL LOCATIONS	4

2. DISASSEMBLY INSTRUCTIONS

2.1 MECHANICAL PARTS	5
2.1.1 FRONT GRILLE	5
2.1.2 CABINET	5
2.1.3 CONTROL BOX	5
2.2 AIR HANDLING PARTS	6
2.2.1 COVER (AT THE TOP)	6
2.2.2 BLOWER.....	6
2.2.3 FAN	6
2.2.4 SHROUD.....	7
2.3 ELECTRICAL PARTS	7
2.3.1 MOTOR	7
2.3.2 COMPRESSOR	7
2.3.3 CAPACITOR	7
2.3.4 POWER CORD	8
2.3.5 THERMISTOR.....	8
2.3.6 SYNCHRONOUS MOTOR.....	8
2.4 REFRIGERATION CYCLE.....	9
2.4.1 CONDENSER	9
2.4.2 EVAPORATOR	9
2.4.3 CAPILLARY TUBE	9

3. INSTALLATION

3.1 HOW TO INSTALL THE UNIT.....	12
3.2 HOW TO USE THE REVERSIBLE INLET GRILLE	12
3.3 WINDOW REQUIREMENTS	13
3.4 INSTALLATION KITS CONTENTS	13
3.5 SUGGESTED TOOL REQUIREMENTS	14
3.6 CABINET INSTALLATION	15

4. TROUBLESHOOTING GUIDE

4.1 OUTSIDE DIMENSIONS.....	17
4.2 PIPING SYSTEM.....	17
4.3 TROUBLESHOOTING GUIDE	18

5. SCHEMATIC DIAGRAM

5.1 CIRCUIT DIAGRAM	27
5.2 ELECTRONIC CONTROL DEVICE	28
5.3 COMPONENTS LOCATION(FOR MAIN P.C.B ASM)	29
5.4 COMPONENTS LOCATION(FOR DISPLAY P.C.B ASM)	29

6. EXPLODED VIEW

.....	30
-------	----

7. REPLACEMENT PARTS LIST.....

.....	31
-------	----

1. PREFACE

This service manual provides various service information, including the mechanical and electrical parts, etc. This room air conditioner was manufactured and assembled under a strict quality control system. The refrigerant is charged at the factory. Be sure to read the safety precautions prior to servicing the unit.

1.1 SAFETY PRECAUTIONS

1. When servicing, set the POWER of CONTROL BOARD to Off and unplug the power cord.
2. Observe the original lead dress.
If a short circuit is found, replace all parts which have been overheated or damaged by the short circuit.
3. After servicing, make an insulation resistance test to prevent the customer's exposure to shock hazards.

1.2 INSULATION RESISTANCE TEST

1. Unplug the power cord and connect a jumper between 2 pins (black and white).
2. The grounding conductor (green or green and yellow) is to be open.
3. Measure the resistance value with an ohm meter between the jumpered lead and each exposed metallic part on the equipment.
4. The value should be over 1 MΩ.

1.3 SPECIFICATIONS

ITEMS		MODELS	CW-XC183HU	CW-XC243HU
POWER SUPPLY	Ø, V, Hz		1, 208/230, 60	
COOLING CAPACITY	Btu/h.		17,800/17,300	23,500/23,000
POWER INPUT	W		1,660/1,620	2,500/2,450
RUNNING CURRENT	A		7.4/7.9	11.2/12.0
EER	Btu/h.W		10.7/10.7	9.4/9.4
REFREIGERANT (R-22) CHARGE			780g (27.5 oz)	980g (34.6oz)
OPERATING TEMPERATURE	INDOOR	°F(°C)	DB : 80(26.7) WB : 67(19.4)	
	OUTDOOR	°F(°C)	DB : 95(35) WB : 75(23.9)	
EVAPORATOR			3 ROW 15 STACKS, SLIT-FIN TYPE	
CONDENSER			2 ROW 19 STACKS, LOUVERED-FIN TYPE	
FAN	INDOOR		TURBO FAN	
	OUTDOOR		PROPELLER TYPE FAN WITH SLINGER-RING	
FAN SPEED	FAN/COOLING		3/3	
FAN MOTOR			6 POLES	
OPERATION CONTROL			REMOTE CONTROL	
ROOM TEMP. CONTROL			THERMOSTAT	
AIR DIRECTION CONTROL	VERTICAL		MANUAL	
	HORIZONTAL		AUTO	
CONSTRUCTION			SLIDE IN-OUT CHASSIS	
PROTECTOR	COMPRESSOR		INTERNAL OVERLOAD PROTECTOR	
	FAN MOTOR		INTERNAL THERMAL PROTECTOR	
POWER CORD			1.6m(63") (3WIRE WITH GROUNDING)	
			ATTACHMENT PLUG(CORD-CONNECTED TYPE)	
DRAIN SYSTEM			DRAIN PIPE OR SPLASHED BY FAN SLINGER	
NET WEIGHT	lbs(kg)		123(55)	146(66)
DIMENSION(W*H*D)	inch(mm)		26 * 16 ^{27/32} * 26 ^{17/32} (660 * 428 * 675)	26 * 16 ^{27/32} * 30 ^{17/32} (660 * 428 * 770)

* DB: Dry Bulb

** WB: Wet Bulb

NOTE : Specifications are subject to minor change without notice for further improvement.

1.4 FEATURES

- Designed for cooling only.
- Powerful and quiet cooling.
- Slide-in and slide-out chassis for the simple installation and service.

- Side air-intake, side cooled-air discharge.
- Built in adjustable THERMISTOR.
- Washable one-touch filter.
- Compact size.

1.5 CONTROL LOCATIONS

• VENTILATION

The ventilation lever must be in the CLOSE position in order to maintain the best cooling conditions.

When a fresh air is necessary in the room, set the ventilation lever to the OPEN position.

The damper is opened and room air is exhausted.

NOTE: Before using the ventilation feature, and prior to installing the front grille, pull down part (A) until level with part (B).

Precaution: The Remote Control unit will not function properly if strong light strikes the sensor window of the air conditioner or if there are obstacles between the Remote Control unit and the air conditioner.

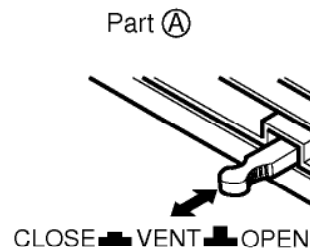
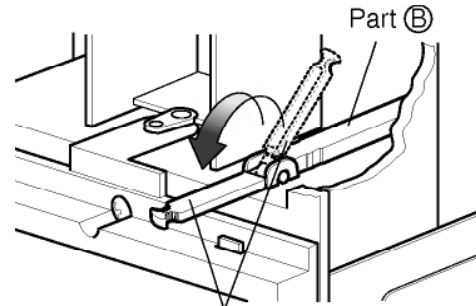

1 POWER BUTTON

Operation starts, when this button is pressed and stops when you press the button again.

2 OPERATION MODE SELECTION BUTTON

Select Cooling, or Fan mode with button.

3 ON/OFF TIMER BUTTON

Set the time of starting and stopping operation. The timer is set by 1 hour.

4 FAN SPEED SELECTOR

Select the fan speed in three steps.
- High [F3] → Low[F1] → Med[F2] → High[F3]...

5 ROOM TEMPERATURE SETTING BUTTON

Control the room temperature within a range of 60°F to 86°F by 1°F.

6 ENERGY SAVER(Available In some models)

The fan stops when the compressor stops cooling. Approximately every 3 minutes the fan will turn on and check the room air to determine if cooling is needed.

7 AIR SWING

Control the horizontal air direction by air swing system.

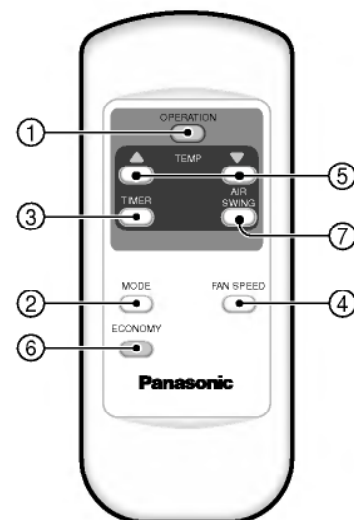
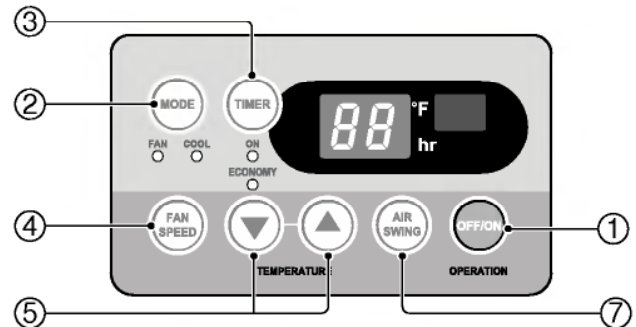

AUTO RESTART

In case the power comes on again after a power failure, the unit runs as previous setting operation.(Available in some models)

2. DISASSEMBLY INSTRUCTIONS

— Before the following disassembly, POWER SWITCH is set to OFF and disconnected the power cord.

2.1 MECHANICAL PARTS

2.1.1 FRONT GRILLE

1. Open the inlet grille upward or downward.
2. Remove the screw which fastens the front grille.
3. Pull the front grille from the right side.
4. Remove the front grille. (See Fig. 1)
5. Re-install the component by referring to the removal procedure.

NOTE: Mark Δ of inlet grille means opening direction.

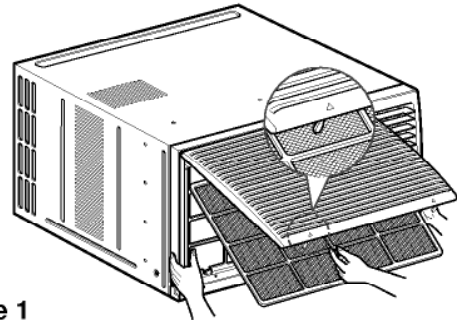

Figure 1

2.1.2 CABINET

1. After disassembling the FRONT GRILLE, remove the screws which fasten the cabinet at both sides. Keep these for later use.
2. Remove the two screws which fasten the cabinet at back. (See Fig. 2)
3. Pull the base pan forward.

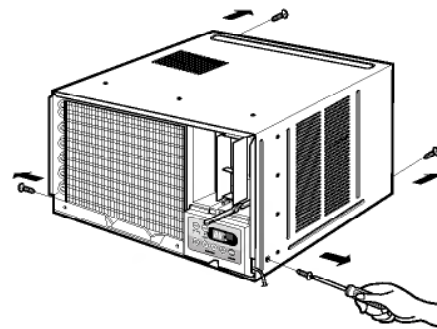

Figure 2

2.1.3 CONTROL BOX

1. Remove the front grille. (Refer to section 2.1.1)
2. Pull the base pan forward so that you can remove the 2 screws which fasten the cover control at the right side. (See Fig. 3)
3. Remove the 3 screws which fasten the control box. (See Fig. 3)
4. Discharge the capacitor by placing a 20,000 ohm resistor across the capacitor terminals.
5. Disconnect two wire housings in the control box.
6. Pull the control box forward completely.
7. Re-install the components by referring to the removal procedure. (See Fig. 3)
(Refer to the circuit diagram found on page 24 in this manual and on the control box.)

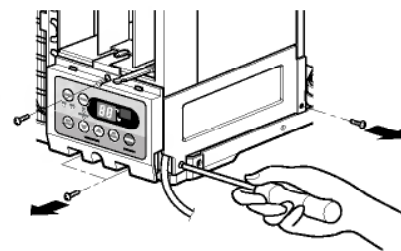

Figure 3

2.2 AIR HANDLING PARTS

2.2.1 COVER (AT THE TOP)

1. Remove the front grille. (Refer to section 2.1.1)
2. Remove the cabinet. (Refer to section 2.1.2)
3. Remove 11 screws which fasten the brace and covers.
4. Remove the covers and the brace. (See Fig. 4)
5. Re-install the components by referring to the removal procedure, above.

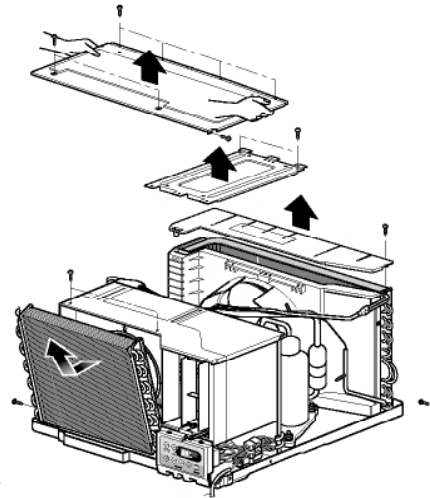

Figure 4

2.2.2 BLOWER

1. Remove the cover. (Refer to section 2.2.1)
2. Remove the 3 screws which fasten the evaporator at the left side and the top side. (See Fig. 4)
3. Move the evaporator sideward carefully.
4. Remove the orifice from the air guide carefully.
5. Remove the clamp spring which is clamped to the boss of blower by hand plier. (See Fig. 5)
6. Pull the blower outward, without touching blades. (See Fig. 6)
7. Re-install the components by referring to the removal procedure, above.

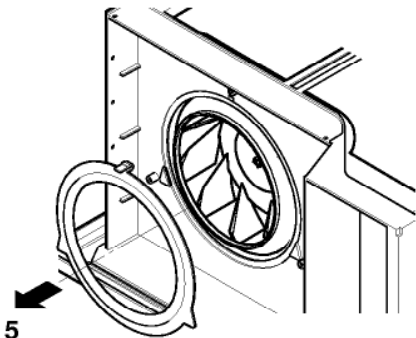

Figure 5

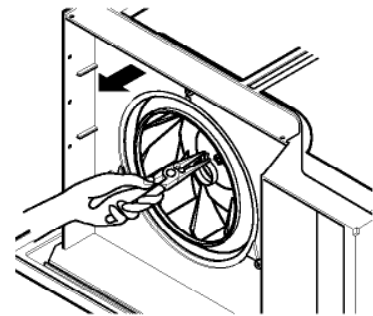

Figure 6

2.2.3 FAN

1. Remove the cabinet. (Refer to section 2.1.2)
2. Remove the brace and shroud cover. (Refer to section 2.2.1)
3. Remove the 5 screws which fasten the condenser.
4. Move the condenser sideways carefully.
5. Remove the clamp which secures the fan.
6. Remove the fan. (See Fig. 7)
7. Re-install the components by referring to the removal procedure, above.

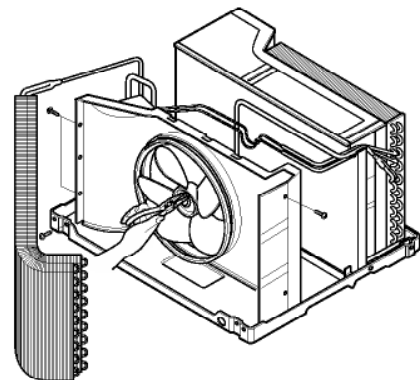

Figure 7

2.2.4 SHROUD

1. Remove the fan. (Refer to section 2.2.3)
2. Remove the 2 screws which fasten the shroud.
3. Remove the shroud. (See Fig. 8)
4. Re-install the component by referring to the removal procedure, above.

2.3 ELECTRICAL PARTS

2.3.1 MOTOR

1. Remove the cabinet. (Refer to section 2.1.2)
2. Remove the cover control and disconnect a wire housing in control box. (Refer to section 2.1.3)
3. Remove the blower. (Refer to section 2.2.2)
4. Remove the fan. (Refer to section 2.2.3)
5. Remove the 4 screws which fasten the motor. (See Fig. 9)
6. Remove the motor.
7. Re-install the components by referring to the removal procedure, above.

Figure 8

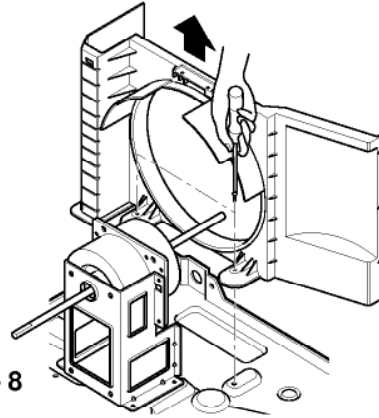
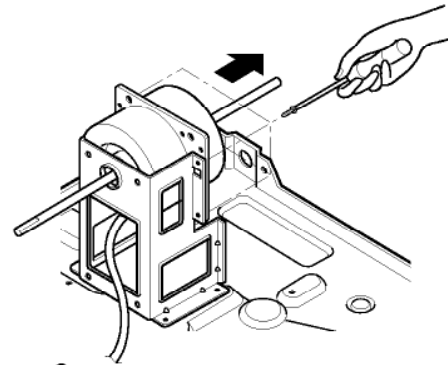

Figure 9



2.3.2 COMPRESSOR

1. Remove the cabinet. (Refer to section 2.1.2)
2. Discharge the refrigerant by using a Refrigerant Recovery System.
3. Disconnect the 3 leads from the compressor.
4. After purging the unit completely, unbrazed the suction and discharge tubes at the compressor connections.
5. Remove the 3 nuts and the 3 washers which fasten the compressor. (See Fig. 10)
6. Remove the compressor.
7. Re-install the components by referring to the removal procedure, above.

Figure 10

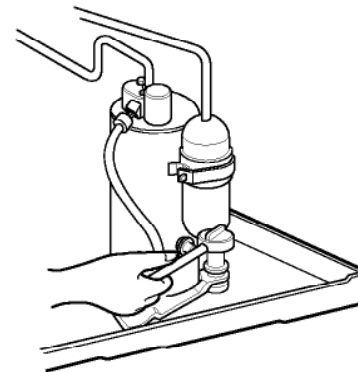

2.3.3 CAPACITOR

1. Remove the control box. (Refer to section 2.1.3)
2. Remove the screw which fasten the display panel.
3. Disconnect the 2 leads from the rocker switch and remove the panel.
4. Remove a screw and unfold the control box. (See Fig. 11)
5. Remove the screw and the clamp which fastens the capacitor. (See Fig. 11)
6. Disconnect all the leads of capacitor terminals.
7. Re-install the components by referring to the removal procedure, above.

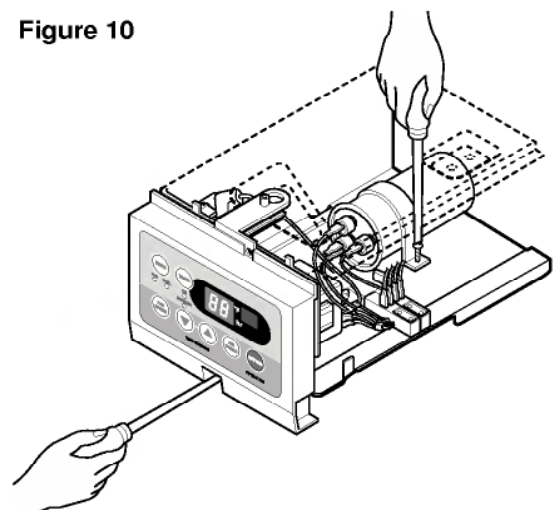

Figure 11

2.3.4 POWER CORD

1. Remove the control box. (Refer to section 2.1.3)
2. Unfold the control box. (Refer to section 2.3.3)
3. Disconnect the grounding screw from the control box.
4. Disconnect 2 receptacles.
5. Remove a screw which fastens the clip cord.
6. Pull the power cord. (See Fig. 12)
7. Re-install the component by referring to the removal procedure, above.
(Use only one ground-marked hole \oplus for ground connection.)
8. If the supply cord of this appliance is damaged, it must be replaced by the special cord.
(The special cord means the cord which has the same specification marked on the supply cord fitted to the unit.)

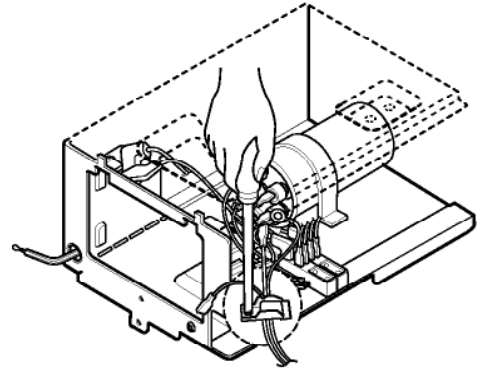

Figure 12

2.3.5 THERMISTOR

1. Remove the control box. (Refer to section 2.1.3)
2. Unfold the control box. (Refer to section 2.3.3)
3. Disconnect the thermistor terminals from main P.W.B assembly.
4. Remove the thermistor.
5. Re-install the components by referring to the removal procedure above. (See Figure 13)

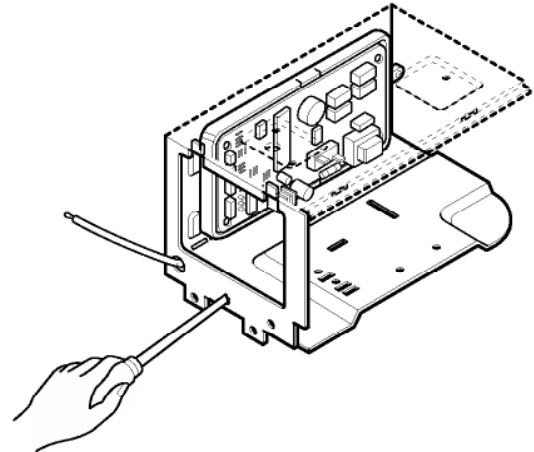

Figure 13

2.3.6 SYNCHRONOUS MOTOR

1. Remove the control box. (Refer to section 2.1.3)
2. Unfold the control box. (Refer to section 2.3.3)
3. Remove the crankshaft.
4. Disconnect all the leads of the synchronous motor.
5. Remove the 2 screws which fasten the synchronous motor. (See Fig. 14)
6. Re-install the components by referring to the removal procedure, above.

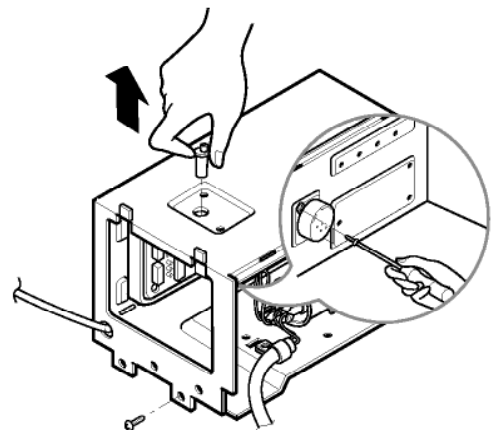

Figure 14

2.4 REFRIGERATION CYCLE

CAUTION

Discharge the refrigerant system using Freon™ Recovery System.
If there is no valve to attach the recovery system, install one (such as a WATCO A-1) before venting the Freon™. Leave the valve in place after servicing the system.

2.4.1 CONDENSER

1. Remove the cabinet. (Refer to section 2.1.2)
2. Remove the brace and the shroud cover. (Refer to section 2.2.1)
3. Remove the 5 screws which fasten the condenser.
4. After discharging the refrigerant completely, unbraid the interconnecting tube at the condenser connections.
5. Remove the condenser.
6. Re-install the components by referring to notes. (See Fig. 15)

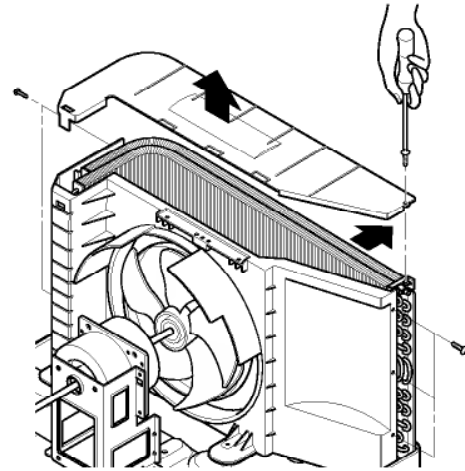

Figure 15

2.4.2 EVAPORATOR

1. Remove the cabinet. (Refer to section 2.1.2)
2. Remove the top cover and the brace. (Refer to section 2.2.1)
3. Discharge the refrigerant completely.
4. Remove the 3 screws which fasten the evaporator at the left side and the top side.
5. Move the evaporator sideward carefully and then unbraid the interconnecting tube at the evaporator connectors.
6. Remove the evaporator.
7. Re-install the components by referring to notes. (See Fig. 16)

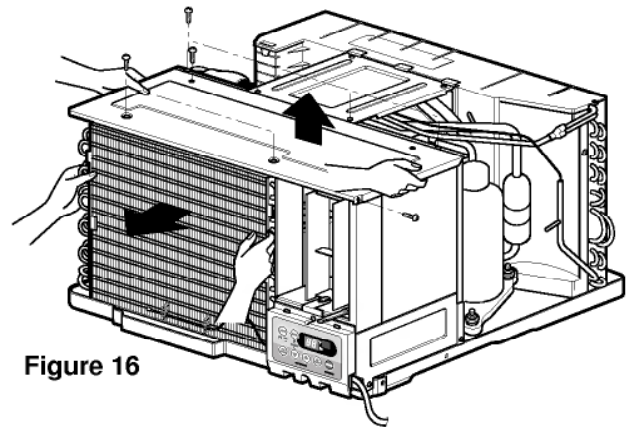

Figure 16

2.4.3 CAPILLARY TUBE

1. Remove the cabinet. (Refer to section 2.1.2)
2. Remove the brace. (Refer to section 2.2.1)
3. After discharging the refrigerant completely, unbraid the interconnecting tube at the capillary tube.
4. Remove the capillary tube.
5. Re-install the components by referring to notes.

NOTES

— Replacement of the refrigeration cycle.

1. When replacing the refrigeration cycle, be sure to discharge the refrigerant system using a Freon™ recovery System.
If there is no valve to attach the recovery system, install one (such as a WATCO A-1) before venting the Freon™. Leave the valve in place after servicing the system.
2. After discharging the unit completely, remove the desired component, and unbrace the pinch-off tubes.
3. Solder service valves into the pinch-off tube ports, leaving the valves open.
4. Solder the pinch-off tubes with Service valves.
5. Evacuate as follows.
 - 1) Connect the vacuum pump, as illustrated Fig. 17A.
 - 2) Start the vacuum pump, slowly open manifold valves A and B with two full turns counterclockwise and leave the valves closed. The vacuum pump is now pulling through valves A and B up to valve C by means of the manifold and entire system.

CAUTION

If high vacuum equipment is used, just crack valves A and B for a few minutes, then open slowly with the two full turns counterclockwise. This will keep oil from foaming and being drawn into the vacuum pump.

- 3) Operate the vacuum pump for 20 to 30 minutes, until 600 microns of vacuum is obtained. Close valves A and B, and observe vacuum gauge for a few minutes. A rise in pressure would indicate a possible leak or moisture remaining in the system. With valves A and B closed, stop the vacuum pump.
- 4) Remove the hose from the vacuum pump and place it on the charging cylinder. See Fig. 17B. Open valve C.
Discharge the line at the manifold connection.
- 5) The system is now ready for final charging.

6. Recharge as follows :

- 1) Refrigeration cycle systems are charged from the High-side. If the total charge cannot be put in the High-side, the balance will be put in the suction line through the access valve which you installed as the system was opened.
- 2) Connect the charging cylinder as shown in Fig. 17B. With valve C open, discharge the hose at the manifold connection.
- 3) Open valve A and allow the proper charge to enter the system. Valve B is still closed.
- 4) If more charge is required, the high-side will not take it. Close valve A.
- 5) With the unit running, open valve B and add the balance of the charge.
 - a. Do not add the liquid refrigerant to the Low-side.
 - b. Watch the Low-side gauge; allow pressure to rise to 30 lbs.
 - c. Turn off valve B and allow pressure to drop.
 - d. Repeat steps B and C until the balance of the charge is in the system.
- 6) When satisfied the unit is operating correctly, use the pinch-off tool with the unit still running and clamp on to the pinch-off tube. Using a tube cutter, cut the pinch-off tube about 2 inches from the pinch-off tool. Use sil-fos solder and solder pinch-off tube closed. Turn off the unit, allow it to set for a while, and then test the leakage of the pinch-off connection.

Equipment needed: Vacuum pump, Charging cylinder, Manifold gauge, Brazing equipment. Pinch-off tool capable of making a vapor-proof seal, Leak detector, Tubing cutter, Hand Tools to remove components, Service valve.

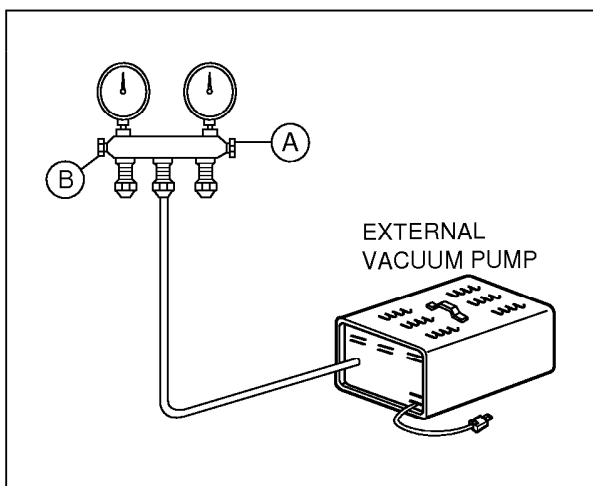
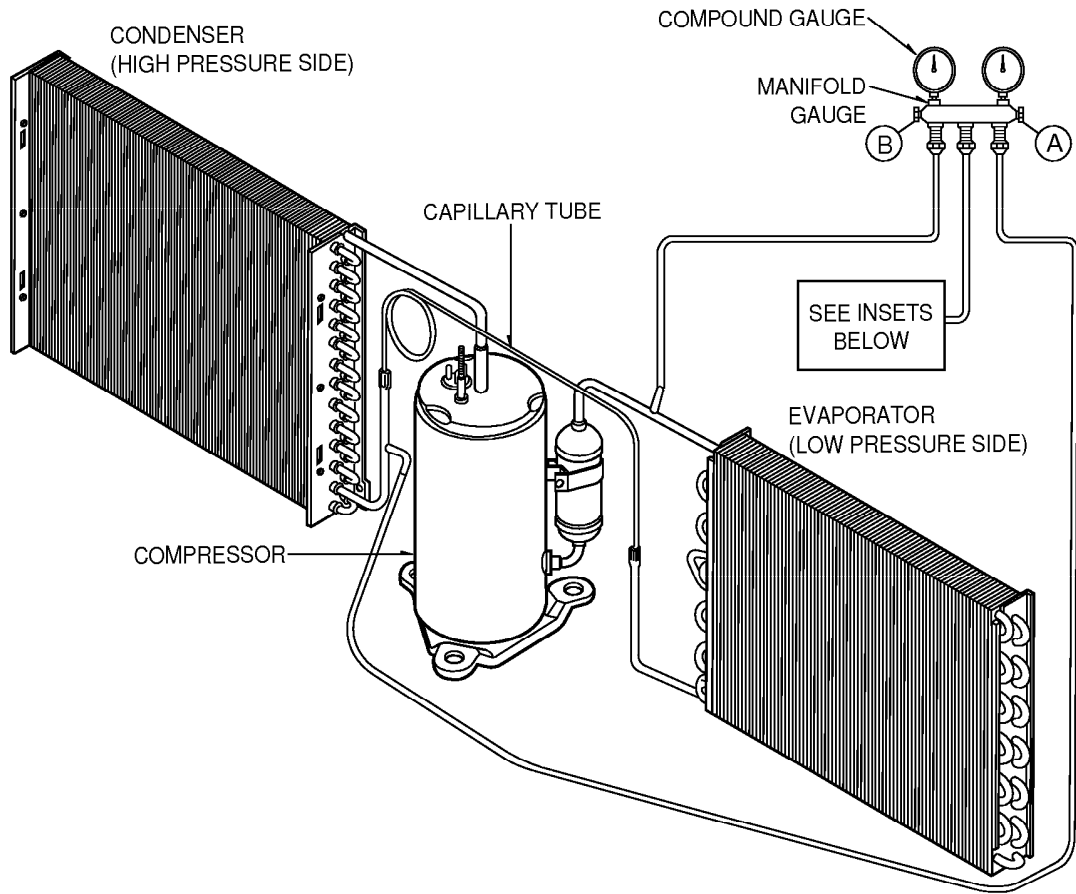

Figure 17A-Pulling Vacuum

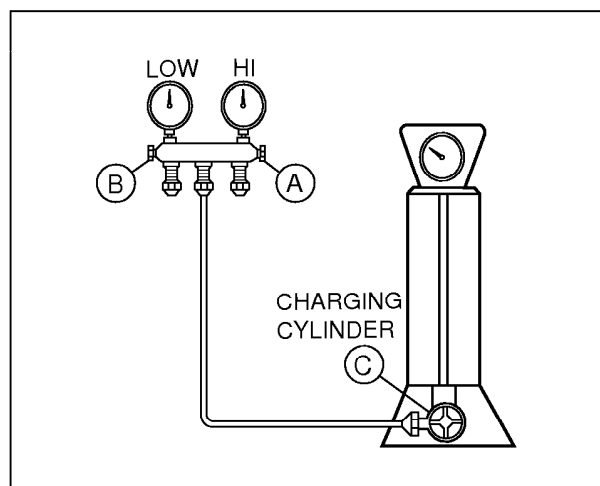
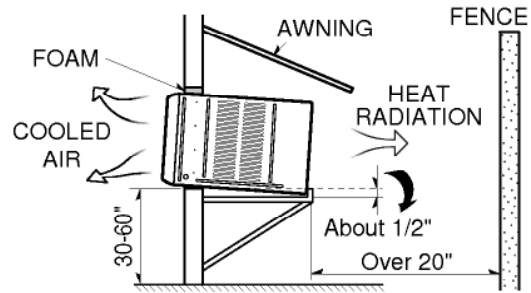
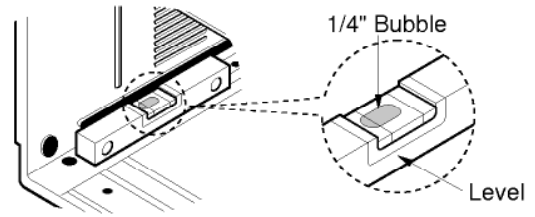

Figure 17B-Charging

3. INSTALLATION

3.1 HOW TO INSTALL THE UNIT

1. To avoid vibration and noise, make sure the unit is installed securely and firmly.
2. Install the unit where the sunlight does not shine directly on the unit.
If the unit receives direct sunlight, build an awning to shade the cabinet.
3. There should be no obstacle, like a fence, within 20" which might restrict heat radiation from the condenser.
4. To prevent reducing performance, install the unit so that louvers of the cabinet are not blocked.
5. Install the unit a little obliquely outward not to leak the condensed water into the room (about 1/2" or 1/4" bubble with level).
6. Install the unit with its bottom portion 30~60" above the floor level.
7. Stuff the foam between the top of the unit and the wall to prevent air and insects from getting into the room.
8. The power cord must be connected to an independent circuit. The green wire must be grounded.
9. Connect the drain tube to the base pan hole in the rear side if you need to drain (consult a dealer).
Plastic hose or equivalent may be connected to the drain tube.



3.2 WINDOW REQUIREMENTS

NOTE: All supporting parts should be secured to firm wood, masonry, or metal.
The models of the specific area don't contain installation feet.

3.2.1 WINDOW REQUIREMENTS

1. This unit is designed for installation in standard double hung windows with actual opening widths from 29" to 41".
The top and bottom window sashes must open sufficiently to allow a clear vertical opening of 18" from the bottom of the upper sash to the window stool.
2. The stool offset (height between the stool and sill) must be less than 1 1/4".

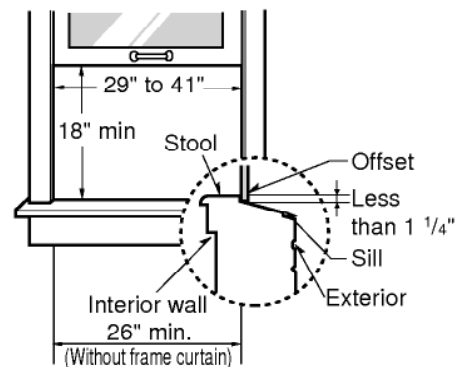

3.3 INSTALLATION KITS CONTENTS

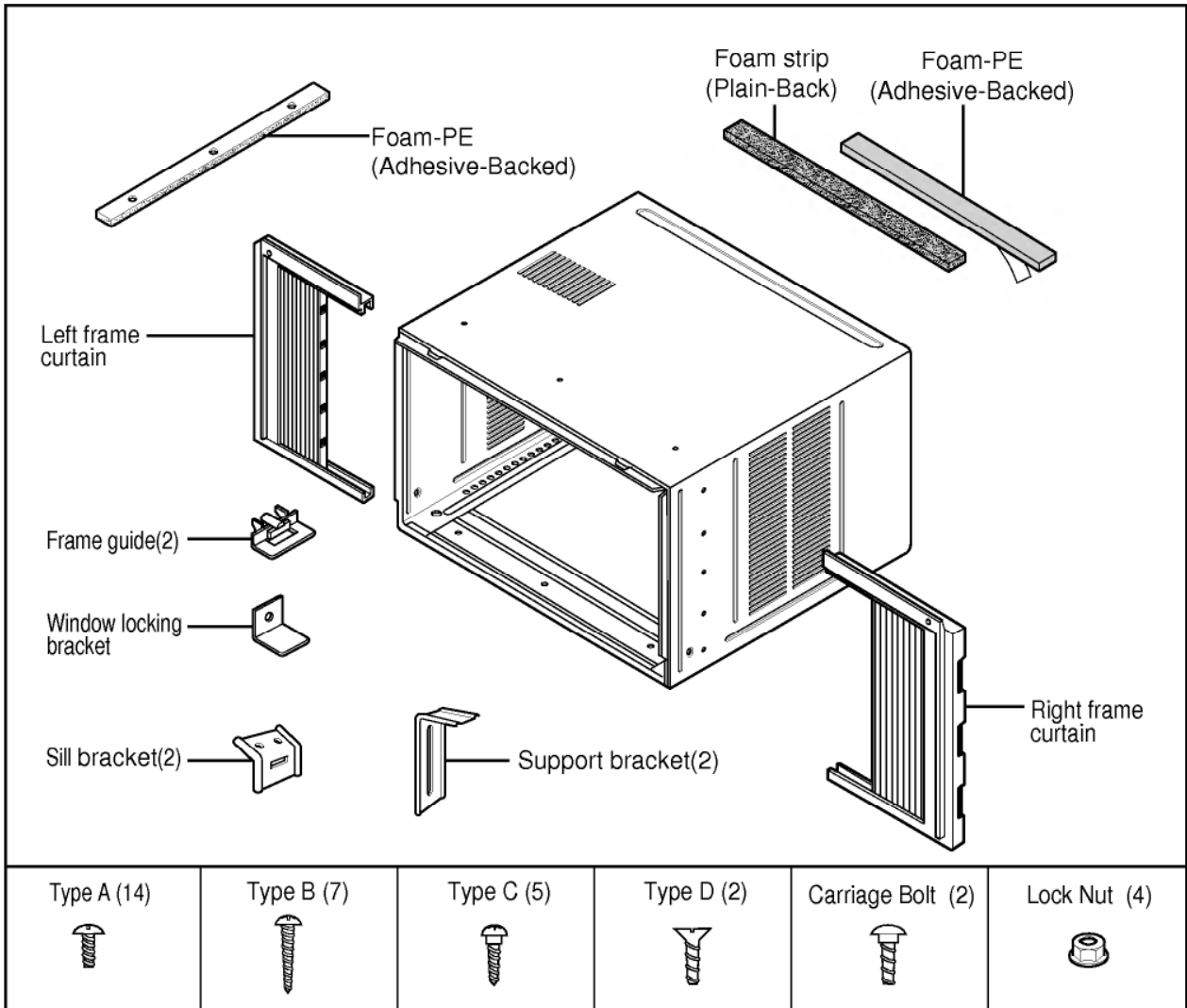

3.4 SUGGESTED TOOL REQUIREMENTS

SCREWDRIVER(+, -), RULER, KNIFE, HAMMER, PENCIL, LEVEL

1. Remove the screws which fasten the cabinet at both sides and at the back. Keep these two screws which fasten the cabinet at both sides for later use.

2. Slide the unit out from the cabinet by gripping the base pan handle and pulling forward while bracing the cabinet.

3. Cut the window sash seal to the proper length. Peel off the backing and attach the Foam-PE to the underside of the window sash.

4. Remove the backing from Foam-PE with 3 holes and attach it to the bottom of the Top retainer bar.

5. Attach the Top retainer bar onto the top of the cabinet with 3 screws (Type A).

6. Insert the Frame guides into the bottom of the cabinet.

7. Insert the Frame Curtain into the Top retainer bar and Frame guides.

8. Fasten the curtains to the unit with 10 screws (Type A) at both sides.

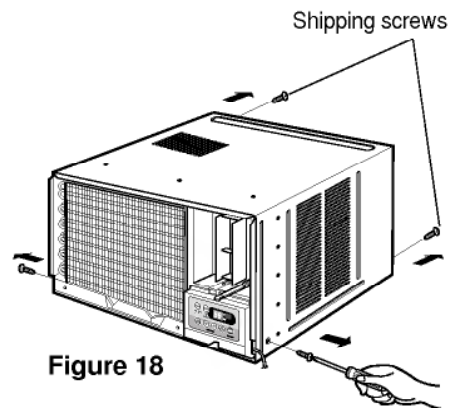

Figure 18

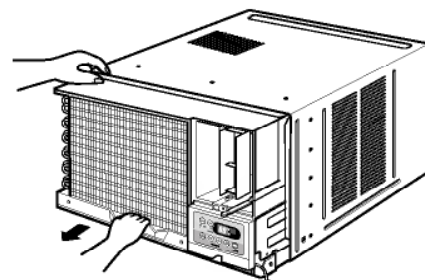

Figure 19

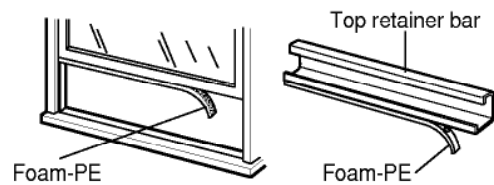

Figure 20

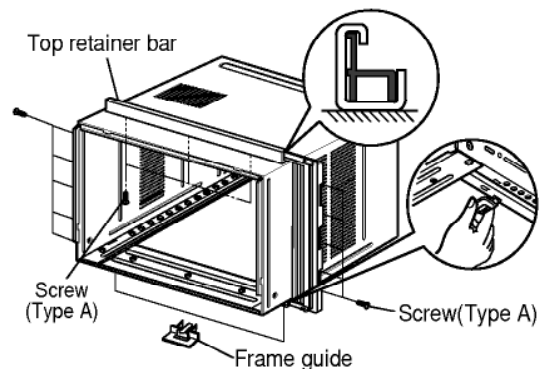
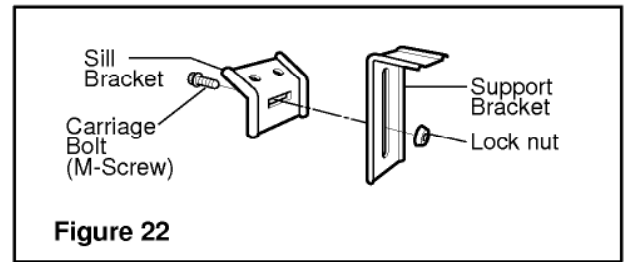

Figure 21

3.5 CABINET INSTALLATION

1. Open the window. Mark a line on the center of the window stool between the side window stop moldings. Loosely attach the sill bracket to the support bracket using the carriage bolt and the lock nut.



2. Attach the sill bracket to the window sill using the screws (Type B). Carefully place the cabinet on the window stool and align the center mark on the bottom front with the center line marked window stool.

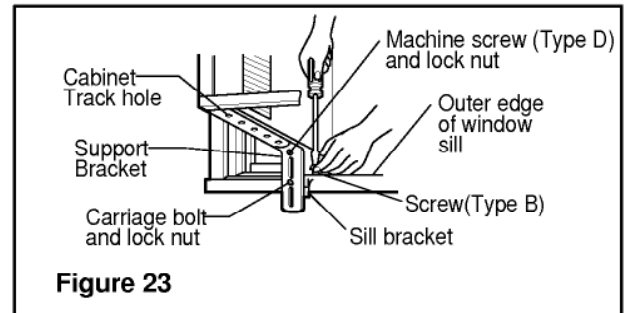

3. Using the M-screw and the lock nut, attach the support bracket to the cabinet track hole. Use the first track hole after the sill bracket on the outer edge of the window sill. Tighten the carriage bolt and the lock nut. Be sure the cabinet slants outward.

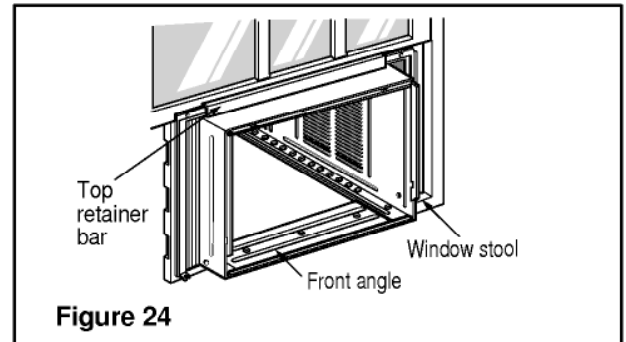

CAUTION: Do not drill a hole in the bottom pan. The unit is designed to operate with approximately 1/2" of water in bottom pan.

4. Pull the bottom window sash down behind the Top retainer bar until they meet.

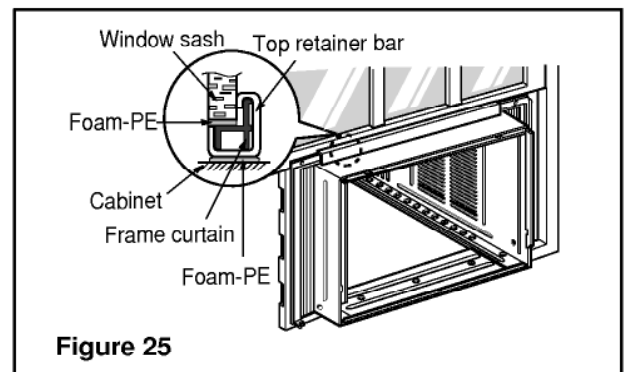

- NOTE:**
1. Do not pull the window sash down so tightly that the movement of Frame curtain is restricted. Attach the cabinet to the window stool by driving the screws (Type B) through the cabinet into window stool.
 2. The cabinet should be installed with a very slight tilt downward toward the outside.

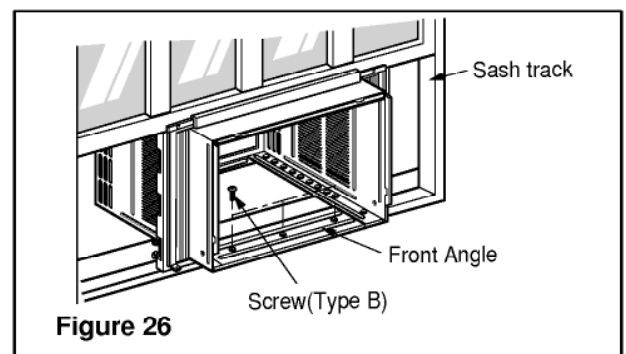

5. Pull each Frame curtain fully to each window sash track, and pull the bottom window sash down behind the Top retainer bar until it meets.

6. Attach each Frame curtain the window sash by using screws (Type C). (See Fig. 27)

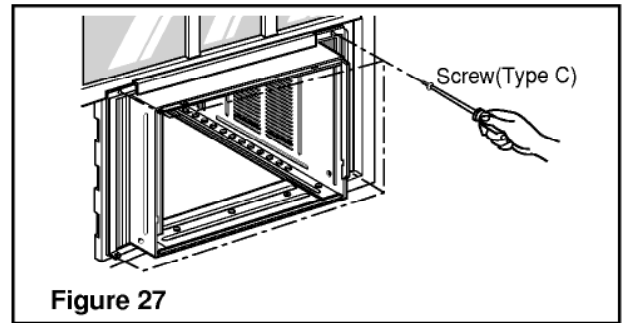

7. Slide the unit into the cabinet. (See Fig. 28)

CAUTION: For security purpose, reinstall screws (Type A) at cabinet's sides.

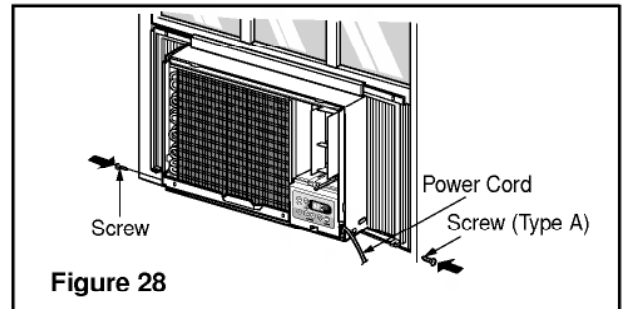

8. Cut the Foam-strip to the proper length and insert between the upper window sash and the lower window sash. (See Fig. 29)

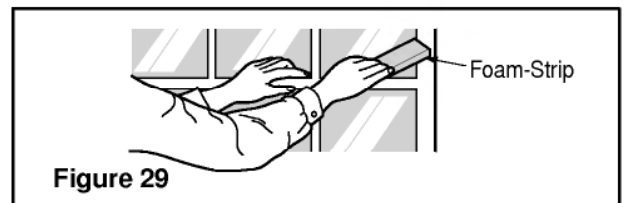

9. Attach the Window locking bracket with a screw (Type C). (See Fig. 30)

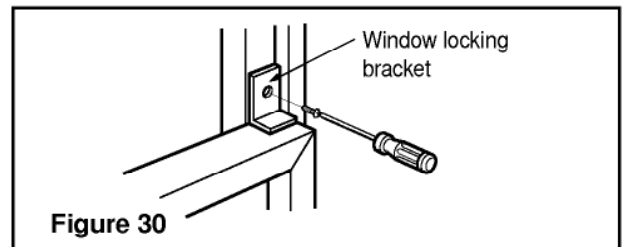

10. Attach the front grille to the cabinet by inserting the tabs on the grille into the tabs on the front of the cabinet. Push the grille in until it snaps into place. (See Fig.31)

11. Lift the inlet grille and secure it with a screw (Type A) through the front grille. (See Fig. 31)

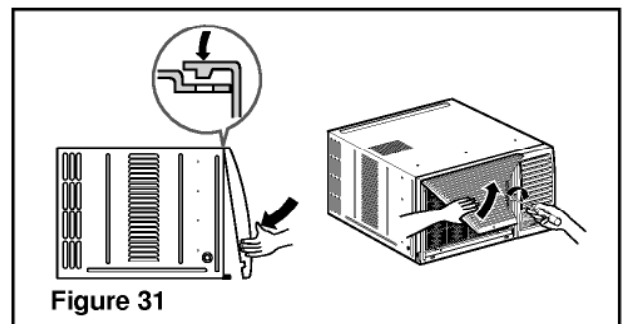

12. **Window installation of room air conditioner is now completed.**

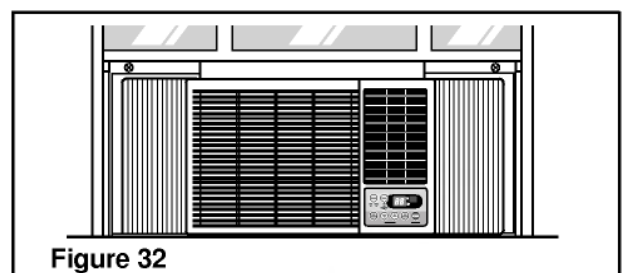

4. TROUBLESHOOTING GUIDE

4.1 OUTSIDE DIMENSIONS

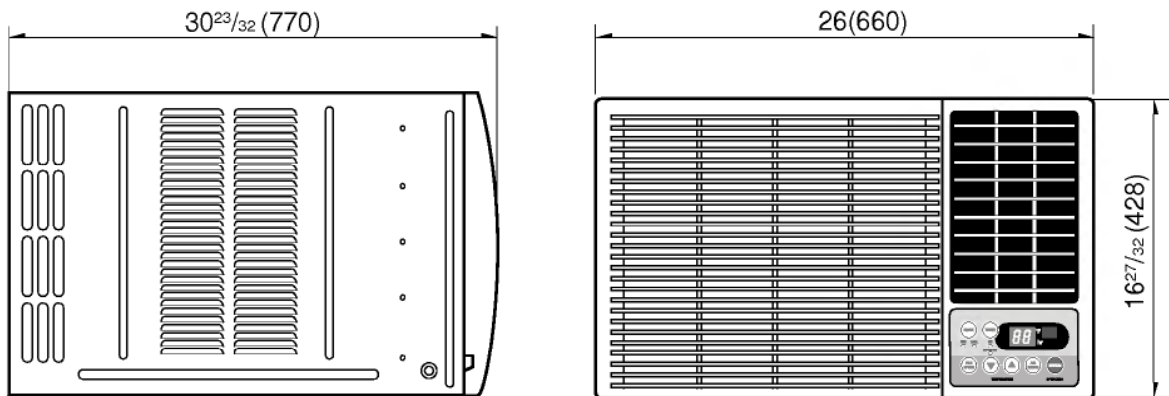

4.2 PIPING SYSTEM

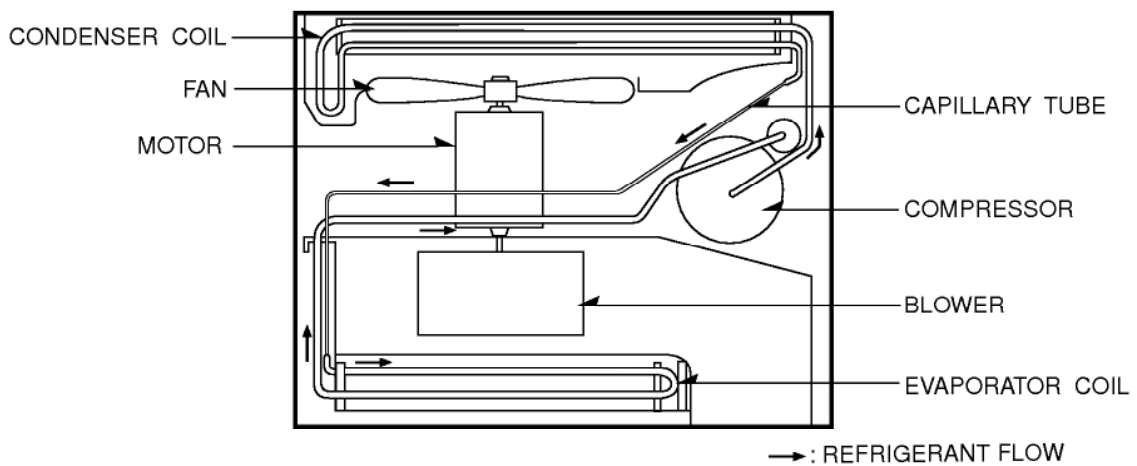

Following is a brief description of the important components and their functions in the refrigeration system. Refer to Fig. 33 to follow the refrigeration cycle and the flow of the refrigerant in the cooling cycle.

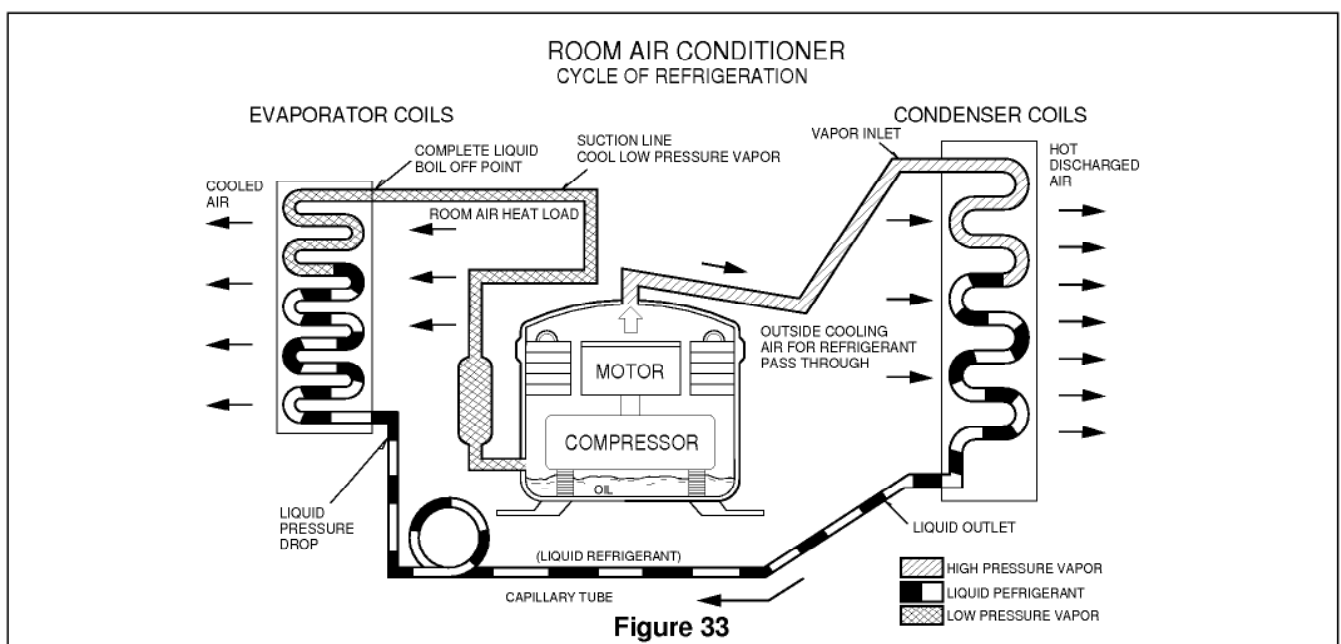

4.3 TROUBLESHOOTING GUIDE

In general, possible trouble is classified in two causes.

The one is called Starting Failure which is caused from an electrical defect, and the other is Ineffective Air Conditioning caused by a defect in the refrigeration circuit and improper application.

Unit runs but poor cooling

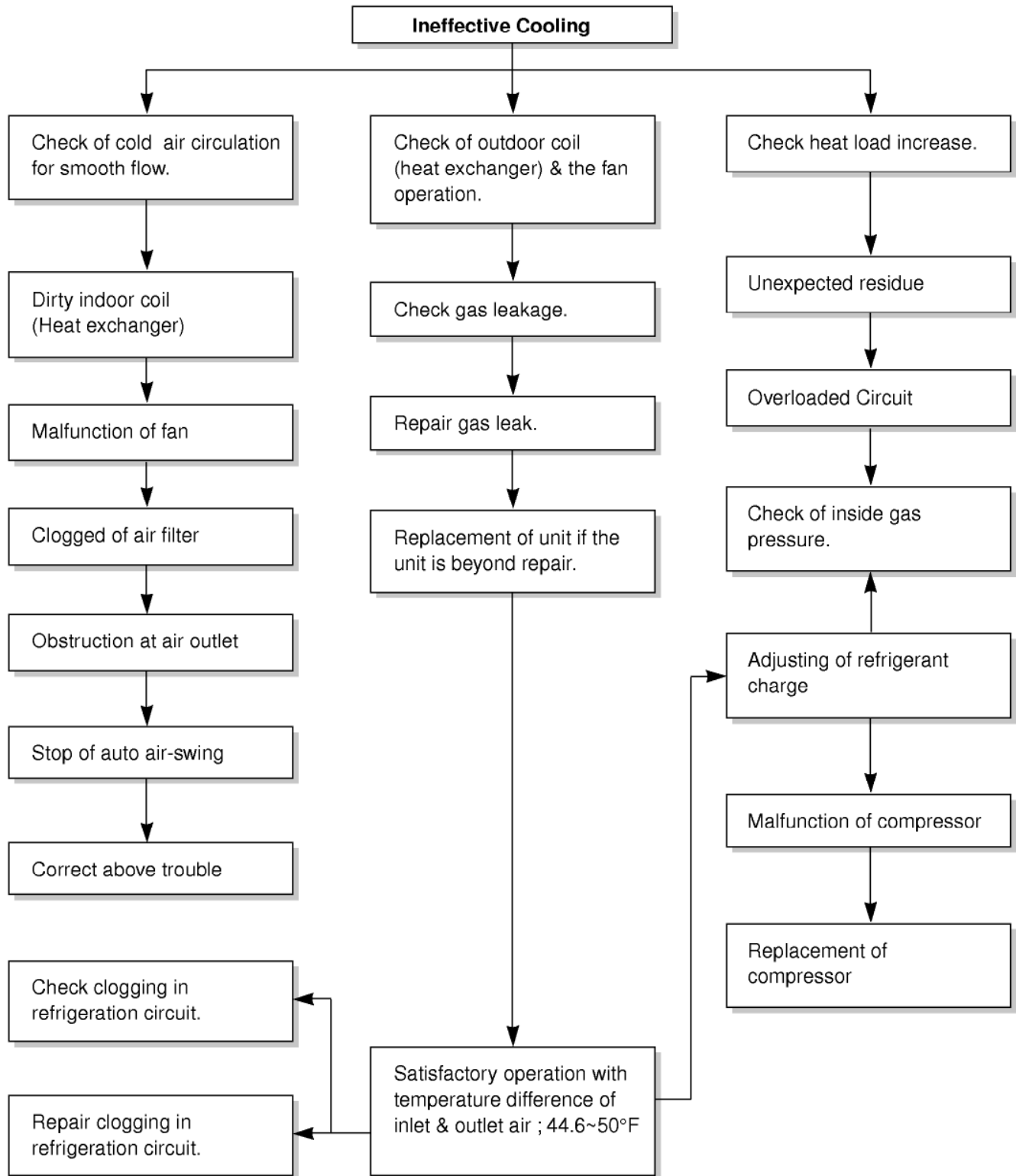

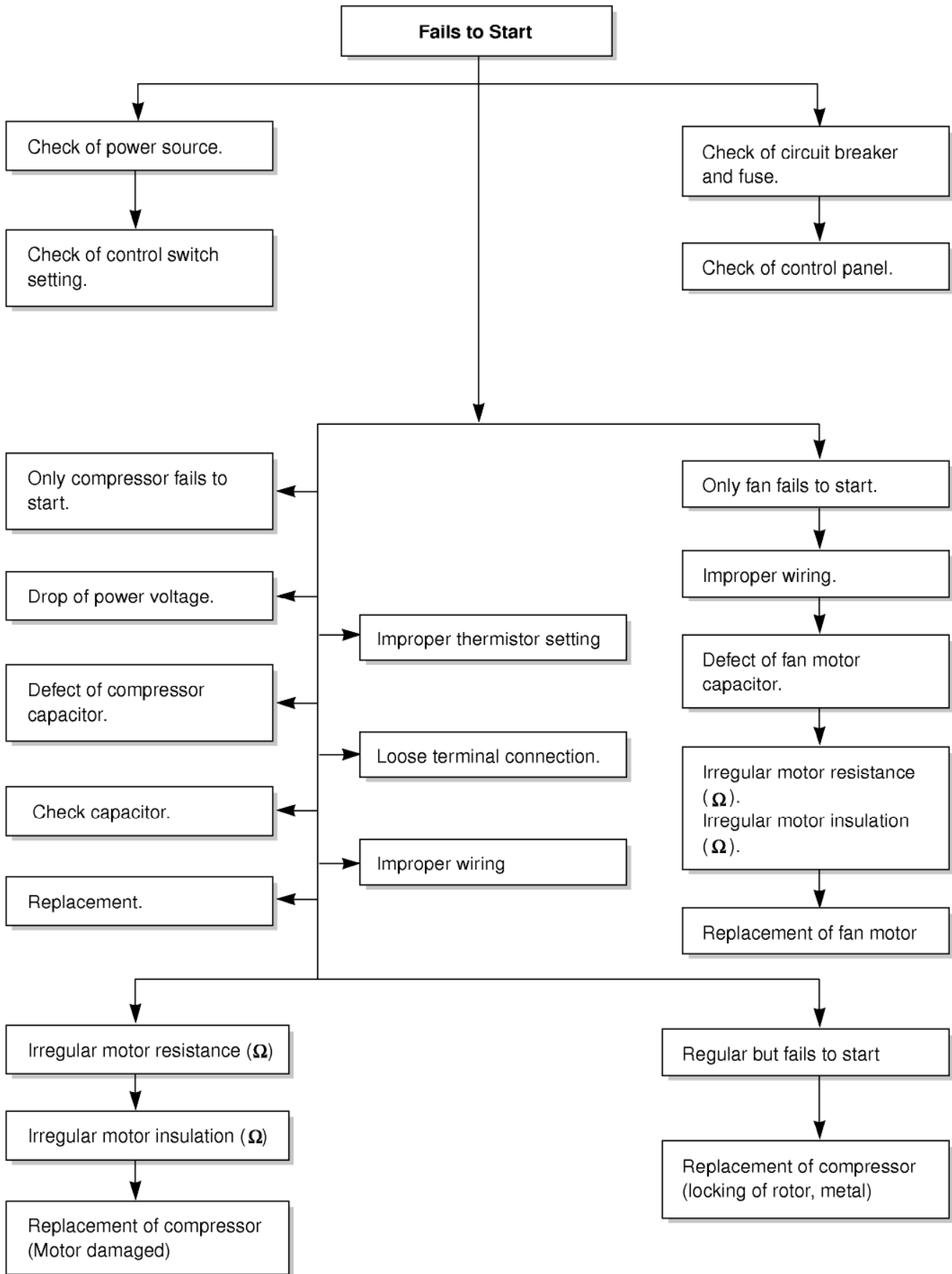

ELECTRIC PARTS TROUBLESHOOTING GUIDE:

Possible Trouble 1

• The unit does not operate.

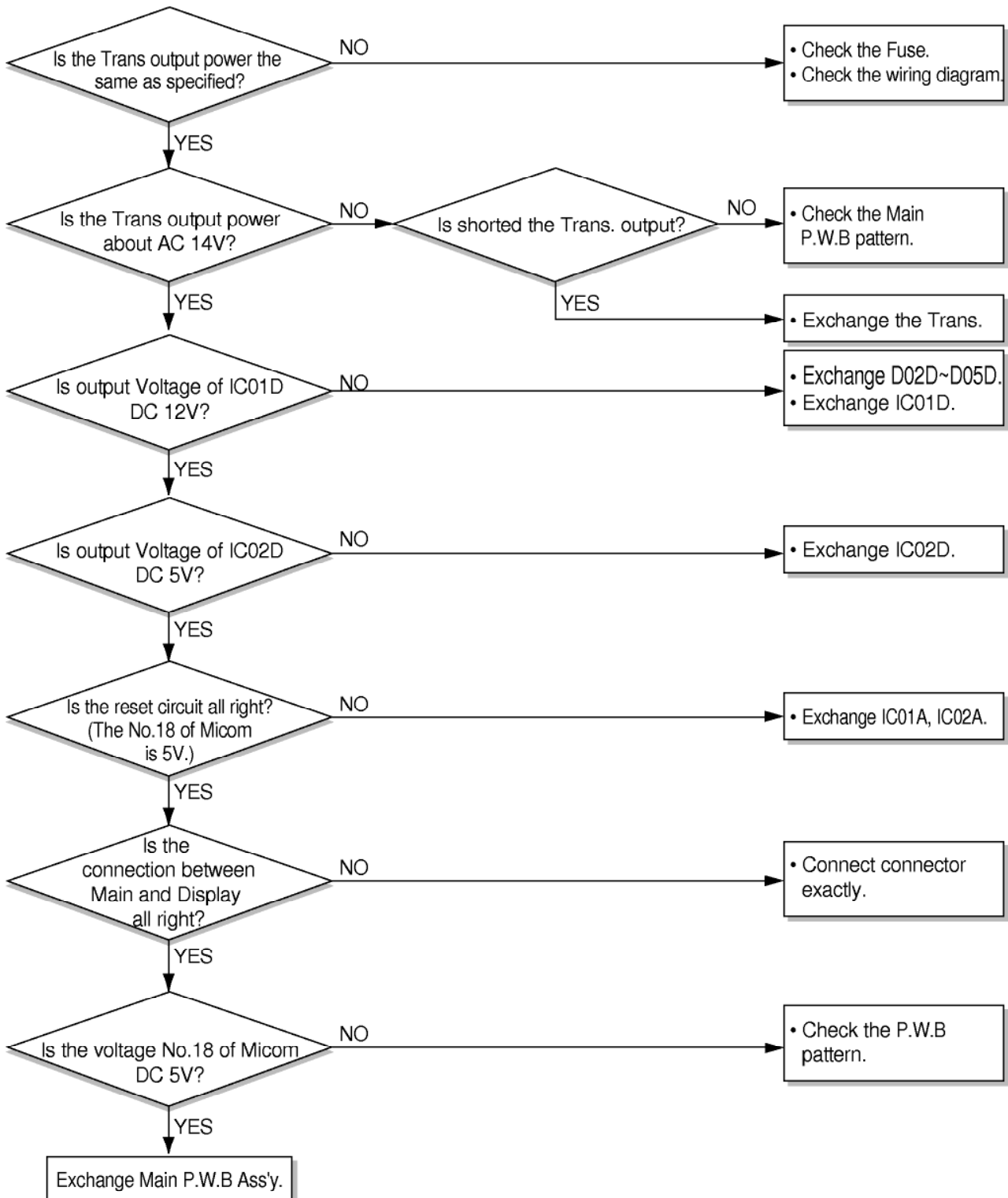

Possible Trouble 2

• The compressor does not operate.

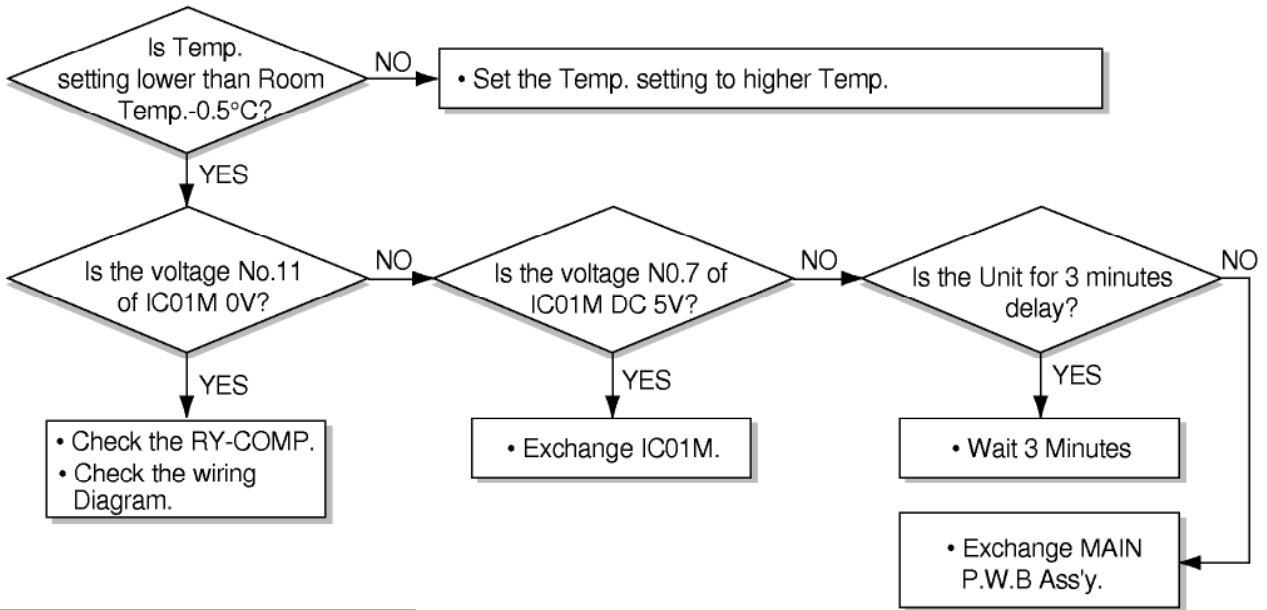

Possible Trouble 3

• The compressor always operate.



Possible Trouble 4

• Fan does not operate.

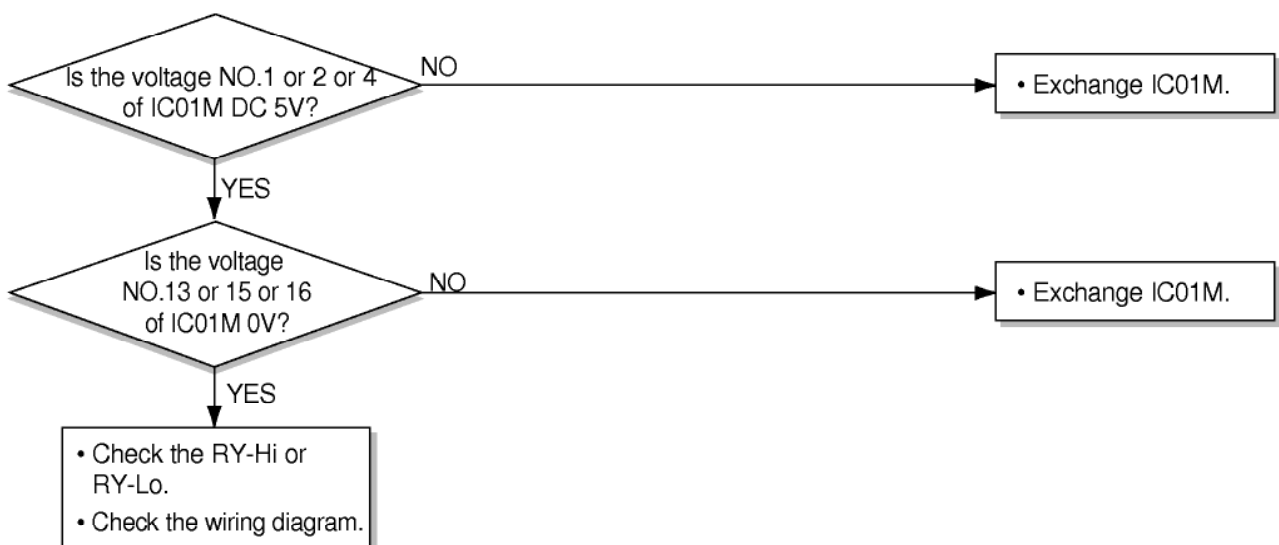

Possible Trouble 5

• Remote controller does not operate.

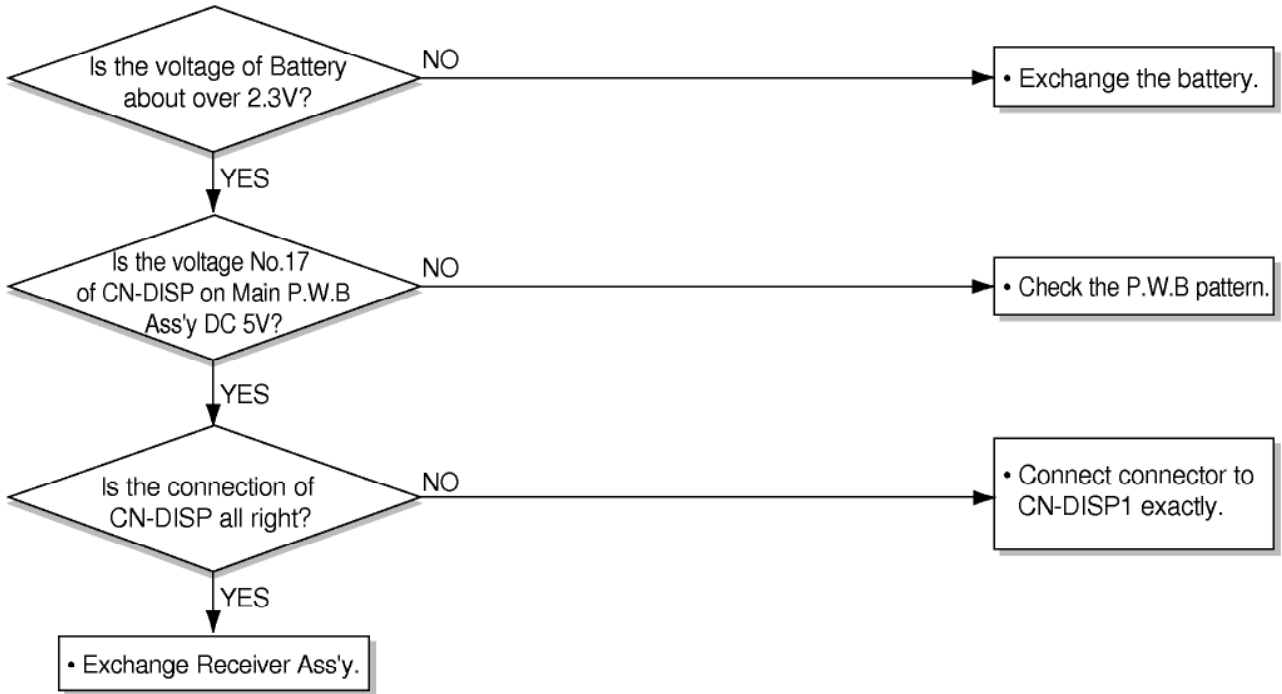

Possible Trouble 6

• It displays abnormally on Display P.W.B Ass'y.

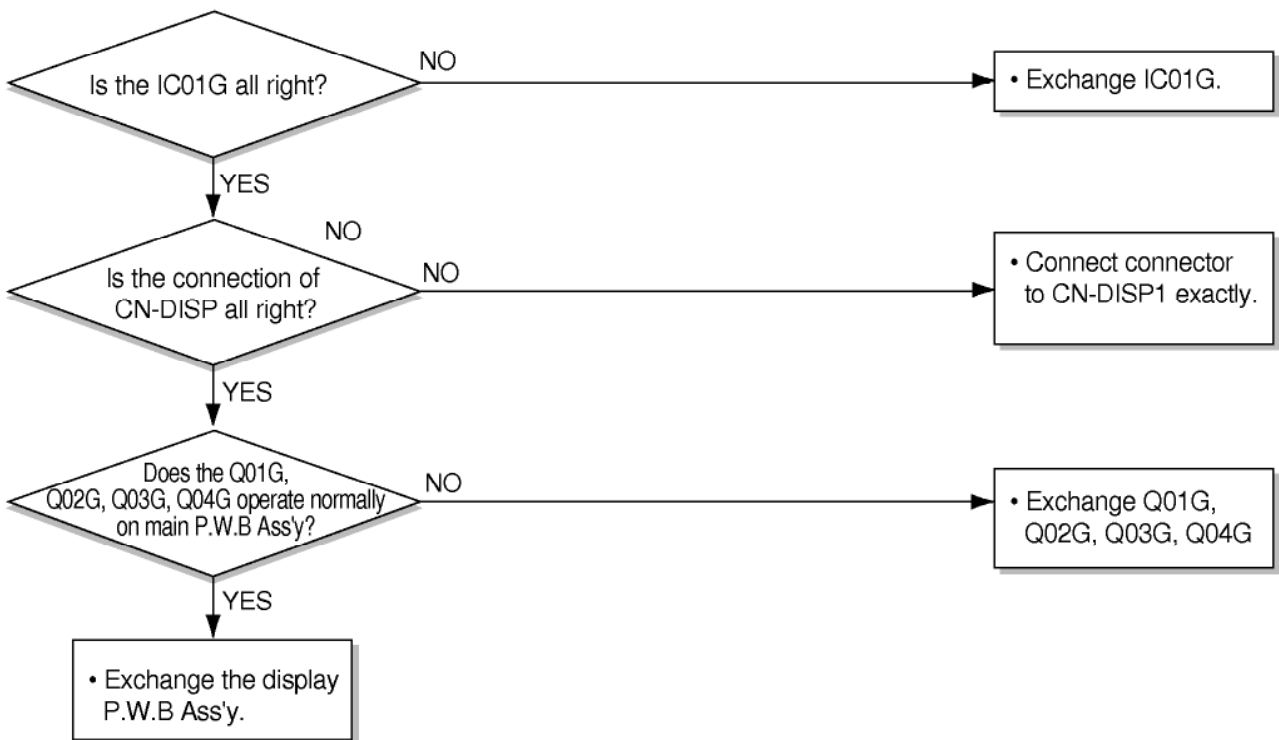

ROOM AIR CONDITIONER VOLTAGE LIMITS

NAME PLATE RATING	MINIMUM	MAXIMUM
AC 208~230 ± 10%	AC 187V	AC 253V

COMPLAINT	CAUSE	REMEDY
Fan motor will not run.	No power	Check voltage at outlet. Correct if none.
	Power supply cord	Check voltage to rotary switch. If none, check power supply cord. Replace cord if circuit is open.
	Rotary switch	Check switch continuity. Refer to wiring diagram for terminal identification. Replace switch if defective.
	Wire disconnected or connection loose	Connect wire. Refer to wiring diagram for terminal identification. Repair or replace loose terminal.
	Capacitor (Discharge capacitor before testing.)	Test capacitor. Replace if not within ±10% of manufacturer's rating. Replace if shorted, open, or damaged.
	Will not rotate	Fan blade hitting shroud or blower wheel hitting scroll. Re-align assembly. Units using slinger ring condenser fans must have 0.22~0.25 inch clearance to the base. If necessary, shim up the bottom of the fan motor with mounting screw(s). Check fan motor bearings; if motor shaft will not rotate, replace the motor.
Fan motor runs.	Revolves on overload	Check voltage. See limits on this page. If not within limits, call an electrician. Test capacitor. Check bearings. Does the fan blade rotate freely? If not, replace fan motor. Pay attention to any change from high speed to low speed. If the speed does not change, replace the motor.

COMPLAINT	CAUSE	REMEDY
Fan motor noise.	Fan	If cracked, out of balance, or partially missing, replace it.
	Blower	If cracked, out of balance, or partially missing, replace it.
	Loose set screw	Tighten it.
	Worn bearings	If knocking sounds continue when running or loose, replace the motor. If the motor hums or noise appears to be internal while running, replace motor.
Compressor will not run, fan motor runs.	Voltage	Check voltage. See the limits on the preceding page. If not within limits, call an electrician.
	Wiring	Check the wire connections; if loose, repair or replace the terminal. If the wires are disconnected, refer to wiring diagram for identification, and replace the wires. Check the wire connections; If not according to the wiring diagram, correct the connections.
	Thermistor	Check the TEMP control. If not at the lowest number, set TEMP control to this setting and restart the unit. Check the continuity of the thermistor. Replace the thermistor if the circuit is open.
	Capacitor (discharge capacitor before servicing.)	Check the capacitor. Replace if not within $\pm 10\%$ of manufacturer's rating, replace if shorted, open, or damaged.
	Compressor	Check the compressor for open circuit or ground. If open or grounded, replace the compressor.
	Overload	Check the compressor overload if externally mounted. Replace if open. (If the compressor temperature is high, remove the overload, cool, and retest.)
Compressor cycles on overload.	Voltage	Check the voltage. See the limits on the preceding page. If voltage is not within these limits, call an electrician.
	Overload	Check overload, if externally mounted. Replace if open. (If the compressor temperature is high, remove the overload, cool, and retest.)

COMPLAINT	CAUSE	REMEDY
Compressor cycles on overload.	Fan motor	If not running, determine the cause. Replace if required.
	Condenser air flow restriction	Remove the cabinet, inspect the interior surface of the condenser. If restricted, clean carefully with a vacuum cleaner (do not damage fins) or brush. Clean the interior base before re-assembling.
	Condenser fins (damaged)	If the condenser fins are closed over a large area on the coil surface, head pressures will increase, causing the compressor to cycle. Straighten the fins or replace the coil.
	Capacitor	Test the capacitor.
	Wiring	Check the terminals. If loose, repair or replace.
	Refrigeration system	Check the system for a restriction.
Insufficient cooling	Air filter	If restricted, clean or replace.
	Ventilation damper door	Close if open.
	Unit undersized	Determine if the unit is properly sized for the area to be cooled.
Excessive noise	Turbo fan	Check the set screw, or clamp. If loose or missing, correct. If the turbo or fan is hitting scroll or barrier, rearrange the air handling parts.
	Copper tubing	Remove the cabinet and carefully rearrange the tubing not to contact the cabinet, compressor, shroud, and barrier.
Auto air-swing fails.	Wiring	Check terminals. If loose, repair or replace.
	Synchronous motor.	Check the synchronous motor for open circuit.

5. SCHEMATIC DIAGRAM

5.1 CIRCUIT DIAGRAM

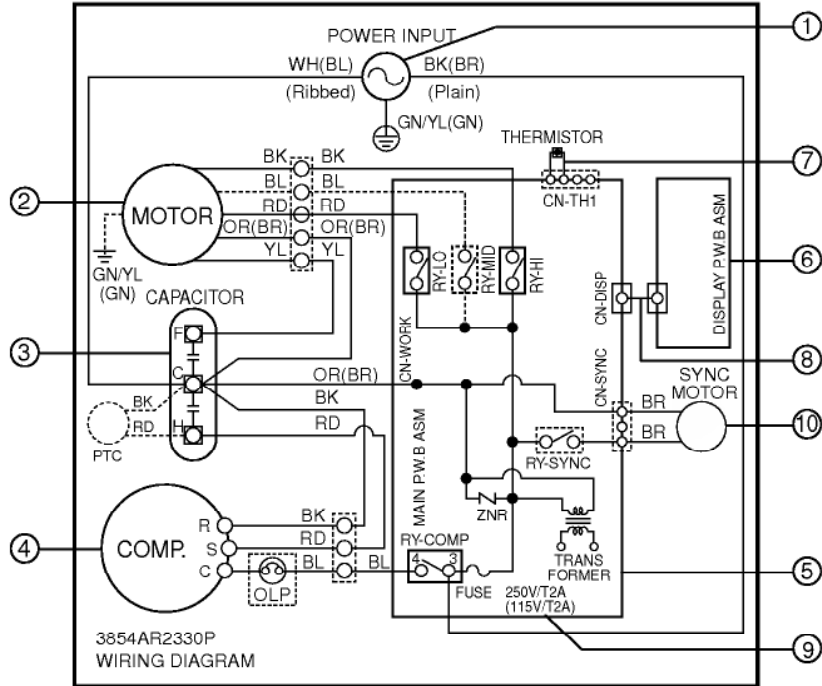

NO.	DESCRIPTION	Q'TY
1	POWER CORD	1
2	FAN MOTOR	1
3	CAPACITOR	1
4	COMPRESSOR	1
5	MAIN PWB ASSEMBLY	1
6	DISPLAY PWB ASSEMBLY	1
7	THERMISTOR ASSEMBLY	1
8	CONNECTOR	1
9	FUSE	1
10	SYNCHRONOUS MOTOR	1

5.2. ELECTOINC CONTROL DEVICE

■ MODEL : CW-XC183HU, CW-XC243HU

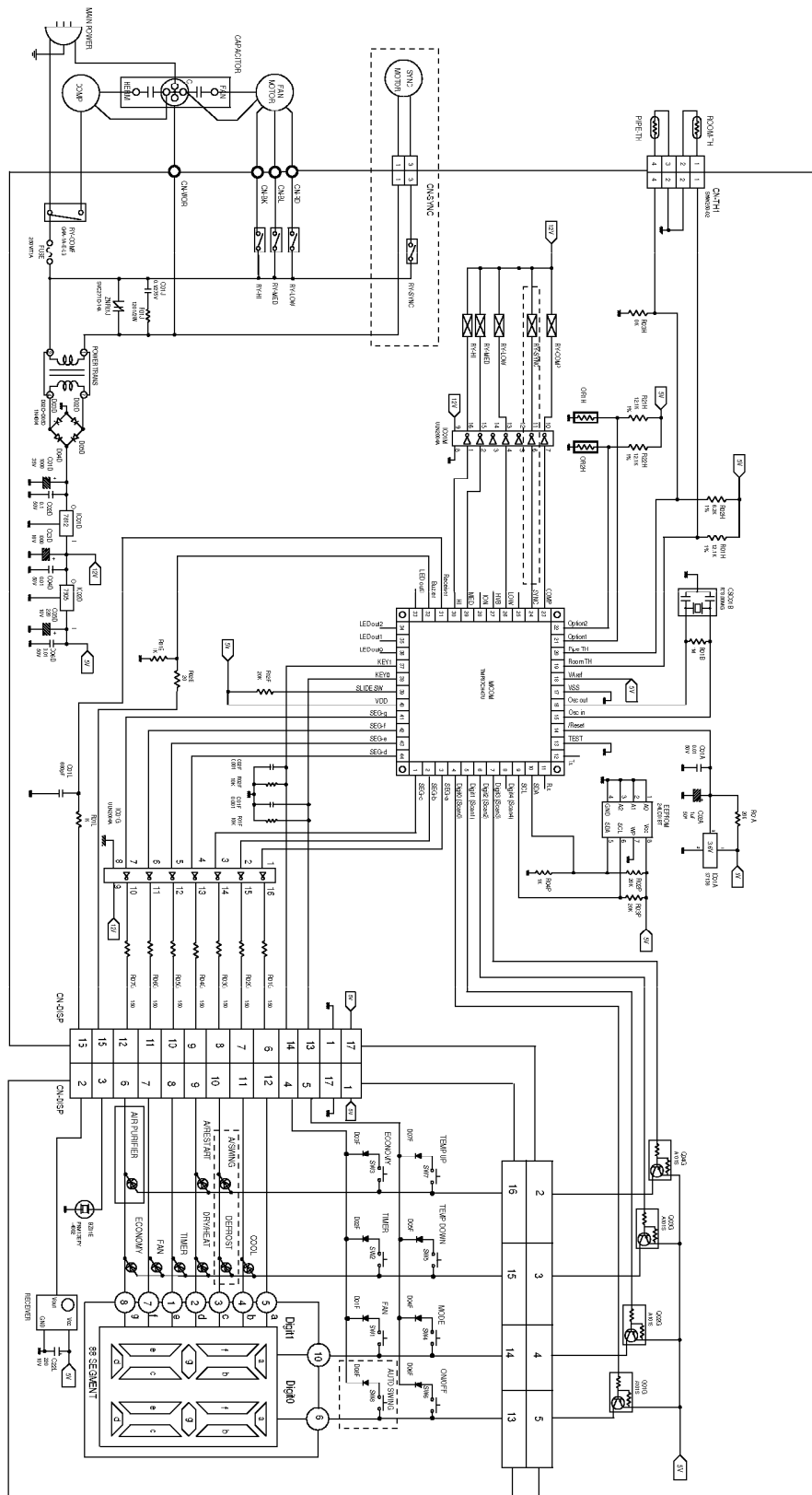

6. EXPLODED VIEW

■ MODEL : CW-XC183HU

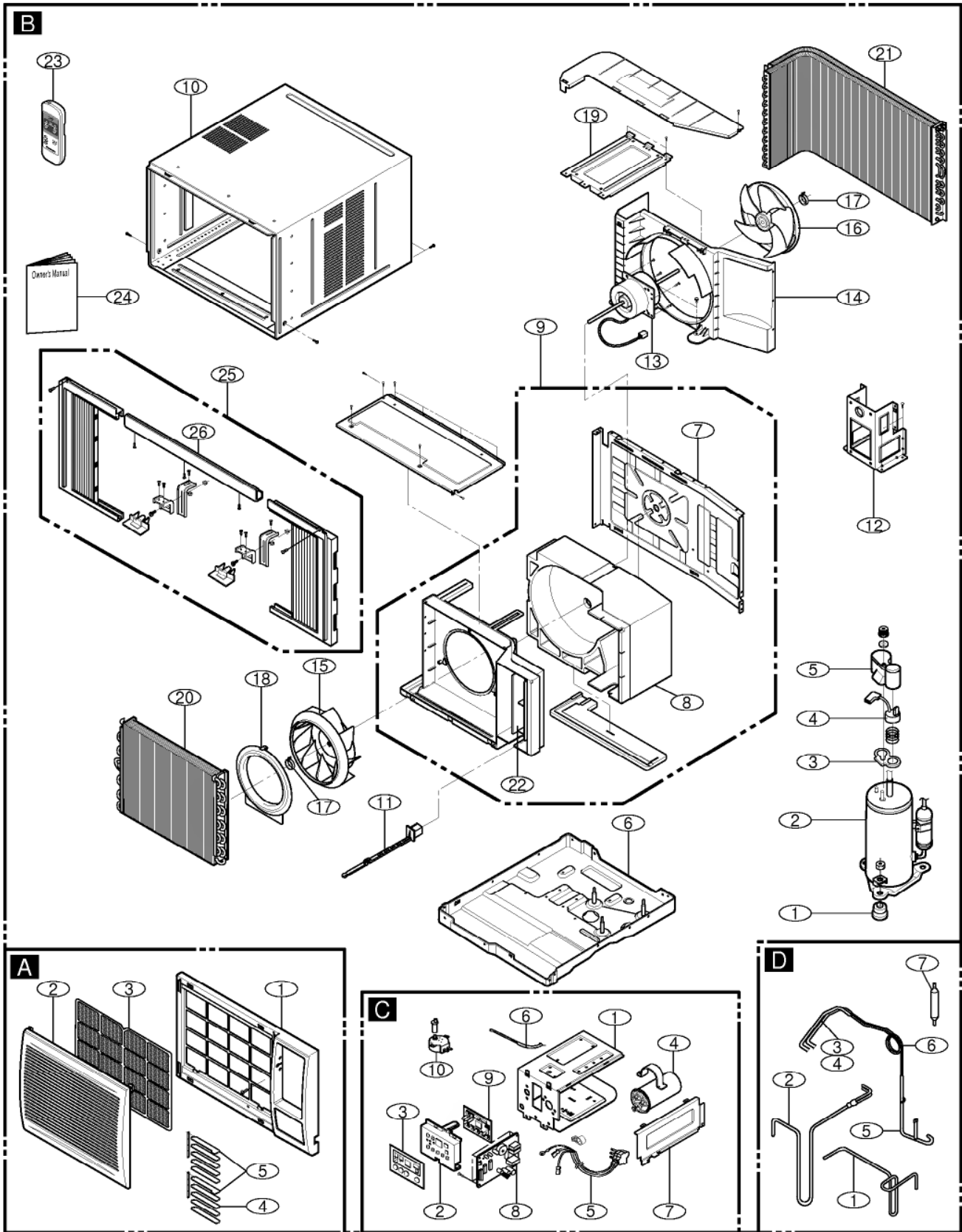

■ MODEL : CW-XC243HU

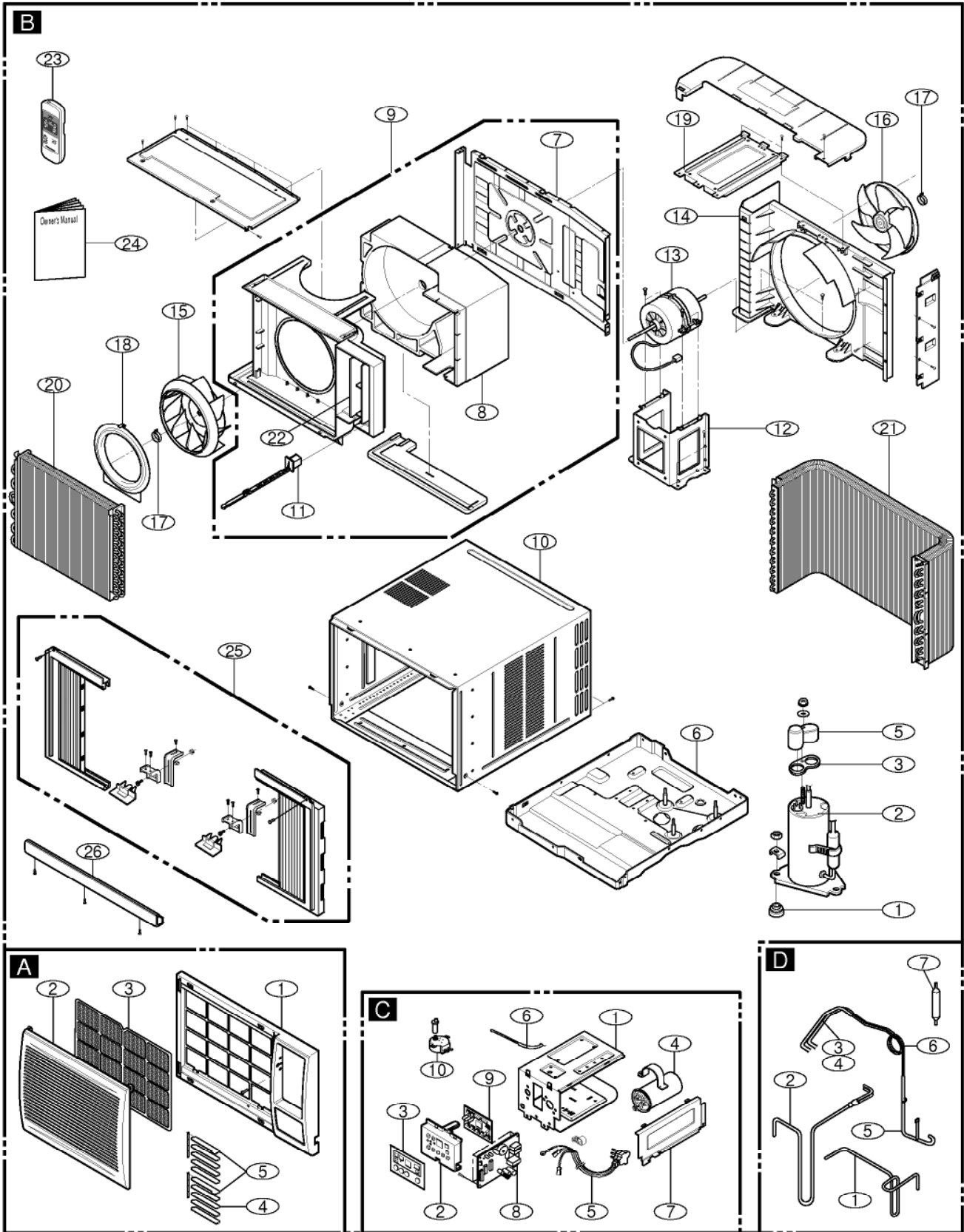

7. REPLACEMENT PARTS LIST

R : Recommendable parts.

LOCATION NO.	DESCRIPTION	PART NO.		REMARK
		CW-XC183HU	CW-XC243HU	
A	FRONT GRILLE ASS'Y	CW353110189A	CW353110189A	R
1	GRILLE, FRONT	CW353010138A	CW353010138A	
2	INLET, GRILLE	CW353010139A	CW353010139A	
3	AIR FILTER ASS'Y	CW5231R6159F	CW5231R6159F	
4	HORIZONTAL, LOUVER	CW4758R7264J	CW4758R7264J	
5	HORIZONTAL, LOUVER	CW4758R7278J	CW4758R7278J	
B	COMP&ACCESSORY ASS'Y			
1	ANTI-VIBRATION BUSH	CW4H00982C	CW4022-L005A	
2	COMPRESSOR	CW2520MBK2KA	CW2520HFK2CA	R
3	GASKET	CW4986-L001G	CW4986-L004A	
4	OVERLOAD PROTECTOR	CW6750-L025A	-	R
5	TERMINAL, COVER	CW3550-L004A	CW3550-L005A	
6	BASE PAN WELD ASS'Y	CW304130002U	CW304110010F	
7	BARRIER, SINGLE	CW479010036A	CW479010036A	
8	SCOLL	CW307220009A	CW307220009A	
9	AIR GUIDE ASSEMBLY	CW523920001V	CW523920001V	
10	CABINET ASS'Y	CW3091R6057A	CW3091R6056A	
11	DAMPER, VENTILATION	CW4900R7265A	CW4900R7265A	
12	MOUNT, MOTOR	CW4960R2895B	CW4960R2895B	
13	MOTOR ASSEMBLY, SINGLE	CW468120011J	CW468120011L	R
14	SHROUD	CW4998R1597A	CW4998R1602A	
15	FAN , TURBO	CW590120009A	CW590120009A	R
16	FAN , AXIAL	CW590120010A	CW5900R1330B	R
17	CLAMP, SPRING	CW3H02932C	CW3H02932C	
18	ORIFICE	CW494820014A	CW494820014A	
19	BRACE	CW4800R7272A	CW4800R7271A	
20	EVAPORATOR ASSEMBLY, FIRST	CW542120017N	CW542120017N	
21	CONDENSER ASSEMBLY, BENT	CW540320062B	CW540320032F	
22	VERTICAL, LOUVER	CW4758R6157A	CW4758R6157A	
23	REMOTE CONTROLLER ASSEMBLY	CW671190018A	CW671190018A	R
24	OPERATING INSTRUCTION	CW382820046F	CW382820046F	
25	INSTALLATION KIT	CW3127R3403U	CW3127R3403U	R
26	UPPER GUIDE	CW2H00858D	CW2H00858D	

LOCATION NO.	DESCRIPTION	PART NO.		REMARK
		CW-XC183HU	CW-XC243HU	
C	CONTROL BOX ASSEMBLY	CW499520215W	CW499520215X	
1	CONTROL BOX, SINGLE	CW4994R1606A	CW4994R1606A	
2	CONTROL PANEL	CW3720R6163A	CW3720R6163A	
3	ESCUTCHEON	CW383110018J	CW383110018J	
4	CAPACITOR	CW6120R2194D	CW6120R2194P	R
5	POWER CORD ASS'Y	CW2H00677X	CW2H00677U	R
6	THERMISTOR	CW632320003D	CW632320003D	R
7	COVER	CW355130015A	CW355130015A	
8	MAIN PWB ASS'Y	CW687110070L	CW687110070L	R
9	DISPLAY PWB ASS'Y	CW687120195Q	CW687120195Q	R
10	MOTOR ASS'Y, SYNC.	CW2H01102A	CW2H01102A	R
D	PIPE			
1	TUBE ASSEMBLY, SUCTION INDOOR	CW521130250D	CW52110094B	
2	TUBE ASSEMBLY, DISCHARGE SINGLE	CW521130066K	CW521130325D	
3	TUBE, EVAPORATOR	CW521030144L	CW521030144U	
4	TUBE, EVAPORATOR	CW521030144T	CW521030144V	
5	TUBE ASSEMBLY, CONNECTOR	CW521110067D	CW521110067C	
6	TUBE, CAPILLARY BEND	CW521120598A	CW521130296E	
7	DRIER ASSEMBLY	CW585130001F	CW585130001K	

MEMO

A series of horizontal dotted lines for writing, spanning the width of the page.

