



website <http://www.lgservice.com>

LG

# LG Room Air Conditioner

## ***SERVICE MANUAL***

**MODELS: HBLG2504E  
LW250CE, LW240CE  
LWHD2500ER**

### **CAUTION**

- BEFORE SERVICING THE UNIT, READ THE SAFETY PRECAUTIONS IN THIS MANUAL.
- ONLY FOR AUTHORIZED SERVICE PERSONNEL.

# TABLE OF CONTENTS

<b>Safety Precautions</b> .....	3
<b>Dimensions</b> .....	5
Outside dimensions.....	5
<b>Product Specifications</b> .....	6
<b>Installation</b> .....	7
Select the Best Location .....	7
Installation Check.....	7
How to Secure the Drain Pipe .....	7
How to Install.....	8
Cabinet Installation.....	9
<b>Operation</b> .....	11
Function of Controls .....	11
<b>Disassembly</b> .....	12
Mechanical Parts.....	12
Air Handling Parts .....	13
Electrical Parts .....	14
Refrigerating Cycle.....	16
<b>Schematic Diagram</b> .....	19
Electronic Control Device .....	19
Wiring Diagram.....	20
Components Location .....	21
<b>Troubleshooting Guide</b> .....	22
Piping System .....	22
Troubleshooting Guide .....	23
Electrical Parts Troubleshooting Guide .....	25
Electric Parts .....	29
<b>Exploded View</b> .....	35
<b>Replacement Parts List</b> .....	36

# Safety Precautions



To prevent injury to the user or other people and property damage, the following instructions must be followed.

■ Incorrect operation due to ignoring instruction will cause harm or damage. The seriousness is classified by the following indications.

**⚠ WARNING** This symbol indicates the possibility of death or serious injury.

**⚠ CAUTION** This symbol indicates the possibility of injury or damage to properties only.

■ Meanings of symbols used in this manual are as shown below.

	<b>Be sure not to do.</b>
	<b>Be sure to follow the instruction.</b>

## ⚠ WARNING

### ■ Installation

**Do not use damaged power cord plugs, or a loose socket.**

• There is risk of fire or electric shock.

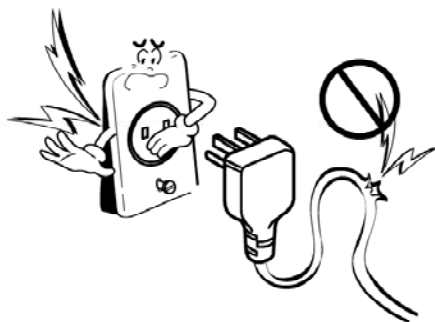

**Always use the power plug and socket with the ground terminal.**

• There is risk of electric shock.

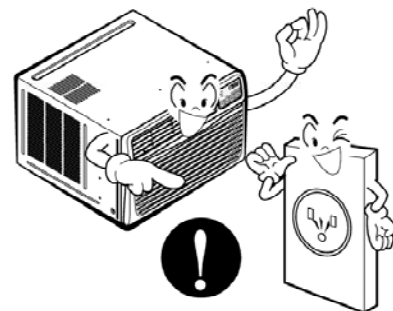

## Safety Precautions

### Do not modify or extend the power cord.

- There is risk of fire or electric shock.

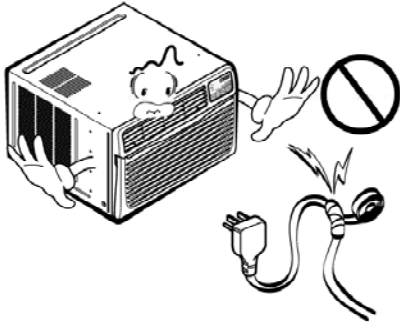

### Do not install, remove, or re-install the unit by yourself(customer).

- There is risk of fire, electric shock, explosion, or injury.



### Be cautious when unpacking and installing the product.

- Sharp edges could cause injury. Be especially careful of the case edges and the fins on the condenser and evaporator.

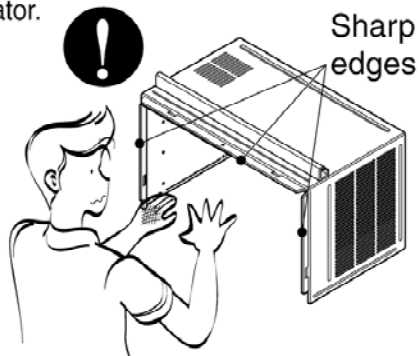

### Do not store or use flammable gas or combustibles near the air conditioner.

- There is risk of fire or failure of product.



### Be sure the installation area does not deteriorate with age.

- If the base collapses, the air conditioner could fall with it, causing property damage, product failure, and personal injury.

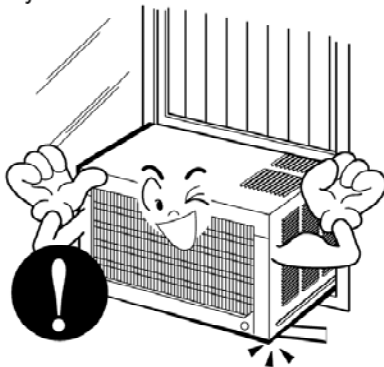



# Dimensions

## Symbols Used in this Manual



This symbol alerts you to the risk of electric shock.



This symbol alerts you to hazards that could cause harm to the air conditioner.

**NOTICE**

This symbol indicates special notes.

## Outside Dimensions

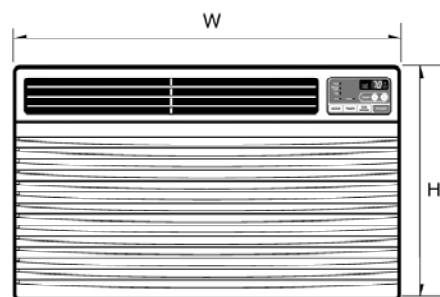
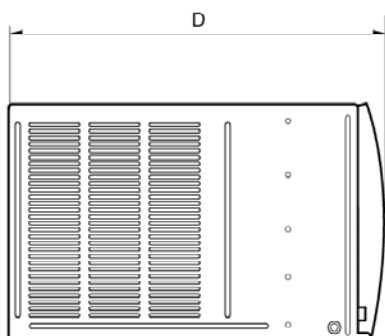

Dimension \ Model		HBLG2504E, LW250CE, LW240CE, LWHD2500ER
W	mm(inch)	660(25 <sup>31</sup> / <sub>32</sub> )
H	mm(inch)	449(17 <sup>11</sup> / <sub>16</sub> )
D	mm(inch)	721(28 <sup>13</sup> / <sub>32</sub> )

## Product Specifications

ITEMS		MODELS	HBLG2504E, LW250CE, LWHD2500ER	LW240CE
POWER SUPPLY			208/230V, 60Hz	
COOLING CAPACITY	(BTU/h)		24,500/25,000	23,150/23,600
INPUT	(W)		2,600/2,660	2,450/2,500
RUNNING CURRENT	(A)		13.0/12.0	13.2/12.2
E.E.R	(BTU/W.h)		9.4	
OPERATING CONDITION	INDOOR (°C)		26.7(DB)* 19.4(WB)**	
	OUTDOOR (°C)		35(DB)* 23.9(WB)**	
REFRIGERANT (R-22) CHARGE			1,080g(38.1 oz)	980g(34.6 oz)
EVAPORATOR			3 ROW 12 STACKS	
CONDENSER			3 ROW 20 STACKS	
FAN, INDOOR			TURBO FAN	
FAN, OUTDOOR			PROPELLER TYPE FAN WITH SLINGER RING	
FAN SPEEDS, FAN/COOLING/HEATING			3/3	
FAN MOTOR			6 POLES	
OPERATION CONTROL			REMOTE CONTROLLER	
ROOM TEMP. CONTROL			THERMISTOR	
AIR DIRECTION CONTROL			VERTICAL LOUVER (RIGHT & LEFT)	
			HORIZONTAL LOUVER (UP & DOWN)	
CONSTRUCTION			SLIDE IN-OUT CHASSIS	
PROTECTOR	COMPRESSOR		OVERLOAD PROTECTOR	
	FAN MOTOR		INTERNAL THERMAL PROTECTOR	
POWER CORD			3 WIRE WITH GROUING	
			ATTACHMENT PLUG (CORD-CONNECTED TYPE)	
DRAIN SYSTEM			DRAIN PIPE OR SPLASHED BY FAN SLINGER	
NET WEIGHT	(lbs/kg)		128/58	
OUTSIDE DIMENSION (W x H x D)	(inch)		25 <sup>31</sup> / <sub>32</sub> X 17 <sup>11</sup> / <sub>16</sub> X 28 <sup>13</sup> / <sub>32</sub>	
	(mm)		660 x 449 x 721	

\* DB : dry bulb

\*\* WB : wet bulb

# Installation

## Select the Best Location

1. To avoid vibration and noise, make sure the unit is installed securely and firmly.
2. Install the unit where the sunlight does not shine directly on the unit.  
If the unit receives direct sunlight, build an awning to shade the cabinet.
3. There should be no obstacle, like a fence, within 20" which might restrict heat radiation from the condenser.
4. To prevent reducing performance, install the unit so that louvers of the cabinet are not blocked.
5. Install the unit a little obliquely outward not to leak the condensed water into the room (about 1/2" or 1/4 bubble with level).
6. Install the unit with its bottom portion 30~60" above the floor level.
7. Stuff the foam between the top of the unit and the wall to prevent air and insects from getting into the room.
8. The power cord must be connected to an independent circuit. The green wire must be grounded.
9. Connect the drain tube to the base pan hole in the rear side if you need to drain (consult a dealer).  
Plastic hose or equivalent may be connected to the drain tube.

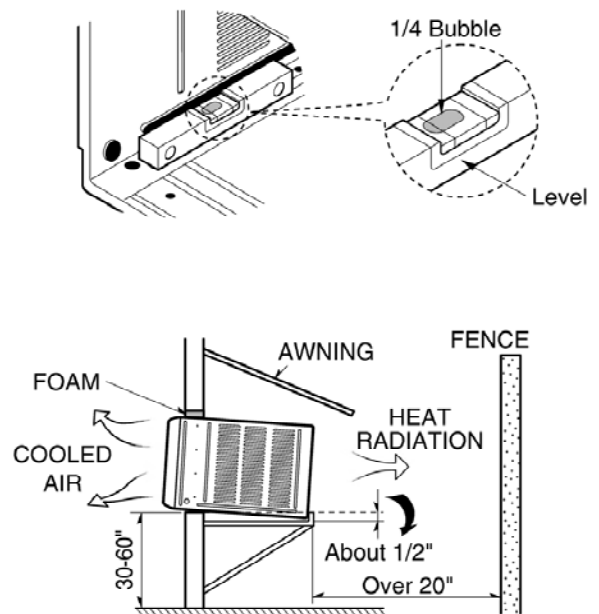

Figure 1

## Installation Check

The setting conditions must be checked prior to initial starting.

The following items are especially important check points when the installation is finished.

1. Grounding wire (Green or Green and Yellow) is provided in the power cord. The green wire must be grounded.
2. Connect to a single-outlet 15A circuit.  
(or 20A circuit for Electric Heater Model)
3. To avoid vibration or noise, make sure the air conditioner is installed securely.
4. Avoid placing furniture or draperies in front of the air inlet and outlet.

## How to Secure the Drain Pipe

In humid weather, excess water may cause the BASE PAN to overflow. To drain the water, remove the DRAIN CAP and secure the DRAIN PIPE to the rear hole of the BASE PAN. Press the drain pipe into the hole by pushing down and away from the fins to avoid injury.

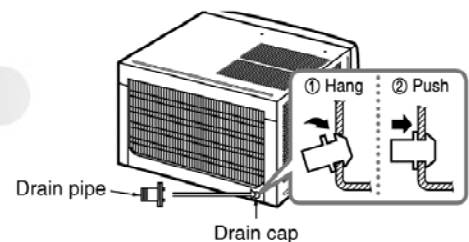

## Optional

1. Install the drain pan over the corner of the cabinet where you removed the plug with 4 (or 2) screws.
2. Connect the drain hose to the outlet located at the bottom of the drain pan. You can purchase the drain hose or tubing locally to satisfy your particular needs. (Drain hose is not supplied).
3. Select the most appropriate connection from among the following figures (by considering the hole of the unit) to fit drain pan to your own unit.

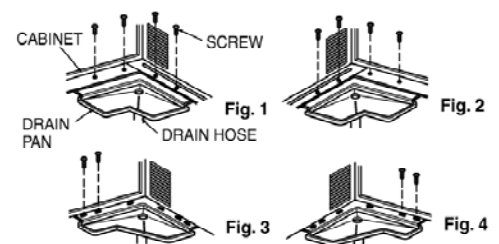

# How to Install

## When Using Installation Kits

### 1. Window Requirements

This unit is designed for installation in standard double hung windows with actual opening widths from 29" to 41". The top and bottom window sash must open sufficiently to allow a clear vertical opening of 19" from the bottom of the upper sash to the window stool.

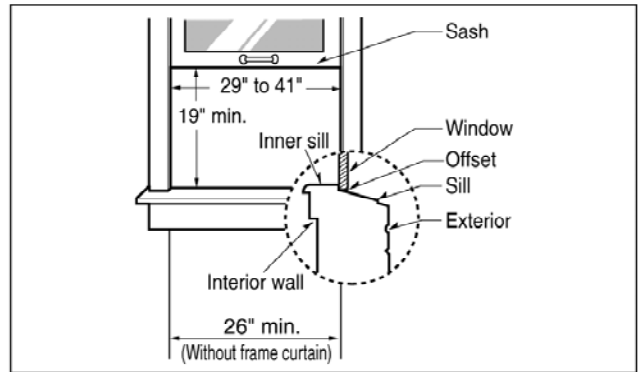

### 2. Installation Kits Contents

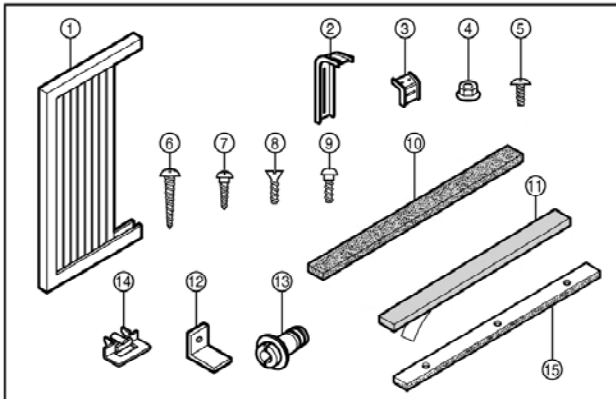

■ Top retainer bar is in the product package.

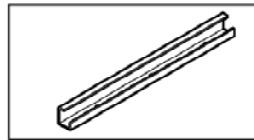

NO.	NAME OF PARTS	Q'TY
1	FRAME CURTAIN	2
2	SUPPORT BRACKET	2
3	SILL BRACKET	2
4	LOCK NUT	4
5	SCREW (TYPE A)	14
6	SCREW (TYPE B)	7
7	SCREW (TYPE C)	5
8	SCREW (TYPE D)	2
9	CARRIAGE BOLT	2
10	FOAM STRIP	1
11	FOAM SEAL	1
12	WINDOW LOCKING BRACKET	1
13	DRAIN PIPE	1
14	FRAME GUIDE	2
15	FOAM-PE	1

## Cabinet Installation

1. Open the window. Mark a line on the center of the window stool between the side window stop moldings.  
Loosely attach the sill bracket to the support bracket using the carriage bolt and the lock nut.

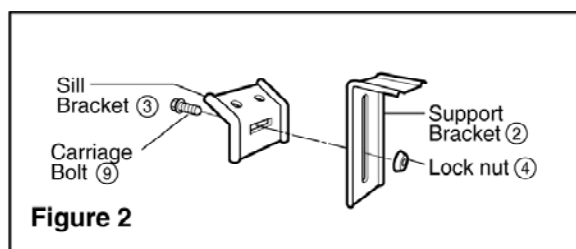

2. Attach the sill bracket to the window sill using the screws (Type B).  
Carefully place the cabinet on the window stool and align the center mark on the bottom front with the center line marked window stool.

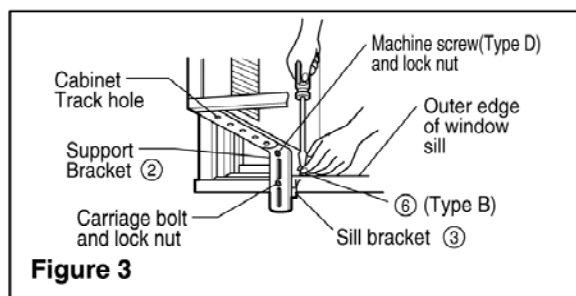

3. Using the M-screw and the lock nut, attach the support bracket to the cabinet track hole. Use the first track hole after the sill bracket on the outer edge of the window sill. Tighten the carriage bolt and the lock nut. Be sure the cabinet slants outward.



**CAUTION: Do not drill a hole in the bottom pan. The unit is designed to operate with approximately 1/2" of water in bottom pan.**

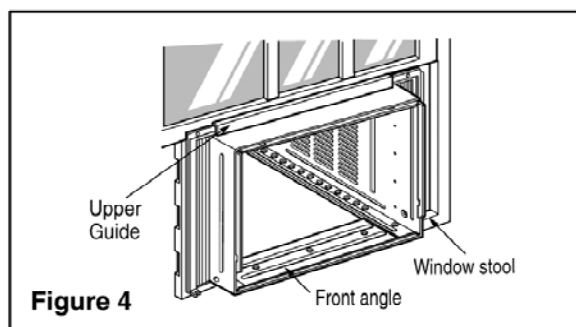

4. Pull the bottom window sash down behind the Top retainer bar until they meet.

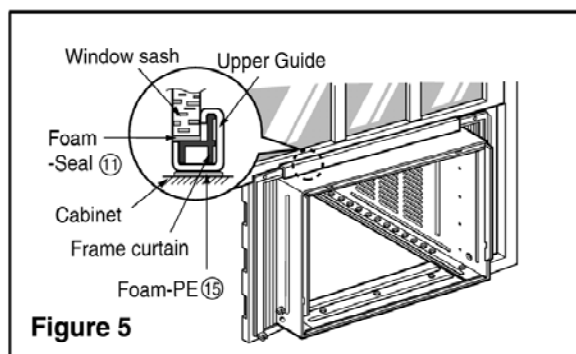

### NOTICE

1. Do not pull the window sash down so tightly that the movement of Frame curtain is restricted. Attach the cabinet to the window stool by driving the screws (Type B) through the cabinet into window stool.
2. The cabinet should be installed with a very slight tilt downward toward the outside.

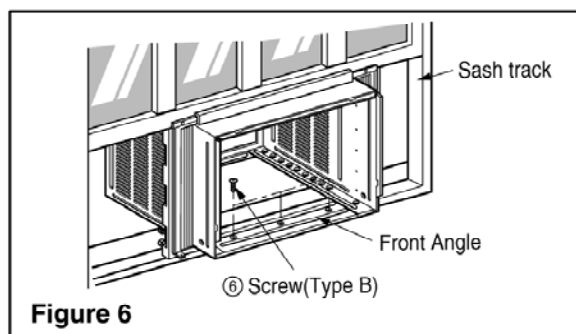

## Installation

5. Pull each Frame curtain fully to each window sash track, and pull the bottom window sash down behind the Top retainer bar until it meets.

6. Attach each Frame curtain the window sash by using screws (Type C). (See Fig. 7)

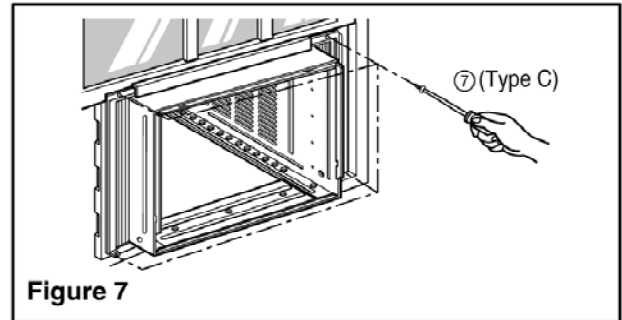

7. Slide the unit into the cabinet. (See Fig. 8)

**CAUTION: For security purpose, reinstall screws (Type A) at cabinet's sides.**

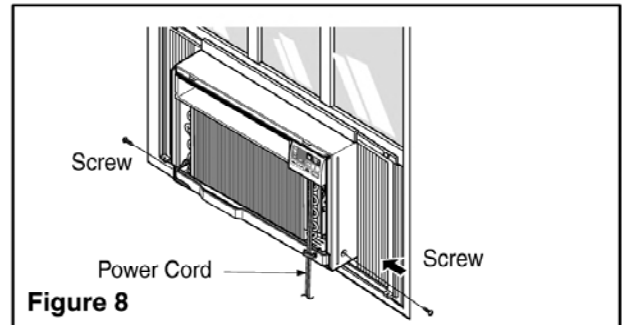

8. Cut the Foam-strip to the proper length and insert between the upper window sash and the lower window sash. (See Fig. 9)

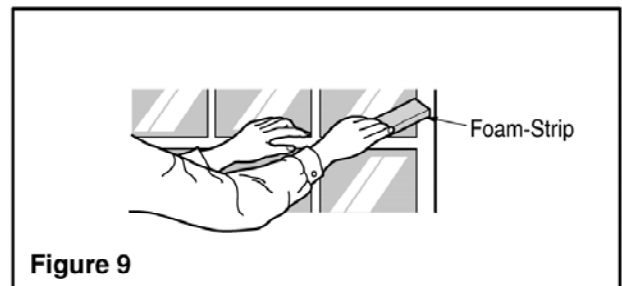

9. Attach the Window locking bracket with a screw (Type C). (See Fig. 10)

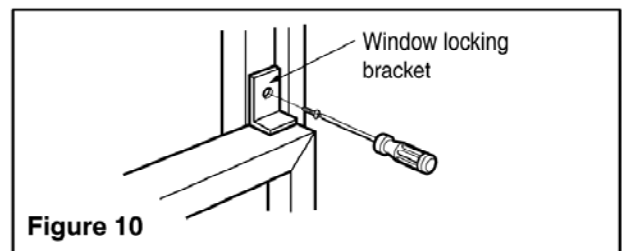

10. Attach the front grille to the cabinet by inserting the tabs on the grille into the tabs on the front of the cabinet. Push the grille in until it snaps into place. (See Fig.11)

11. Lift the inlet grille and secure it with a screw (Type A) through the front grille. (See Fig. 11)

12. **Window installation of room air conditioner is now completed. See ELECTRICAL DATA for attaching power cord to electrical outlet.**

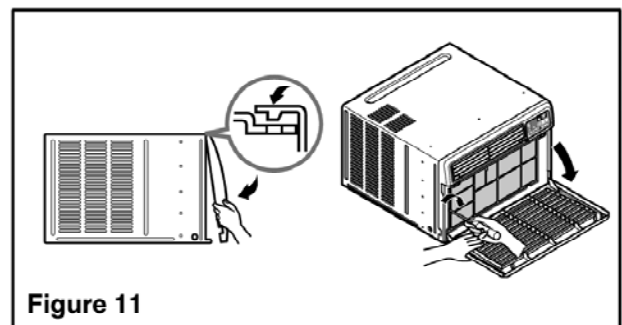

# Operation

## Function of Controls

- Designed for COOLING ONLY.
- Powerful and quiet cooling.
- Slide-in and slide-out chassis for the simple installation and service.
- Low air-intake, top cooled-air discharge.
- Built-in adjustable Thermistor
- Washable one-touch filter
- Compact size
- Equipped with reliable and efficient rotary compressor.

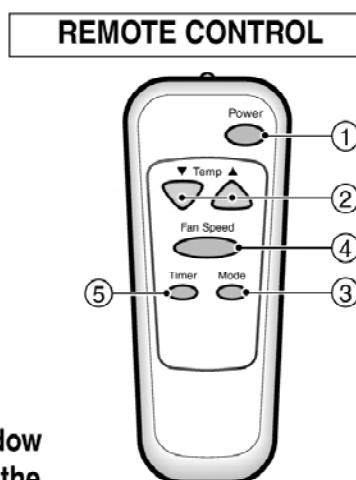
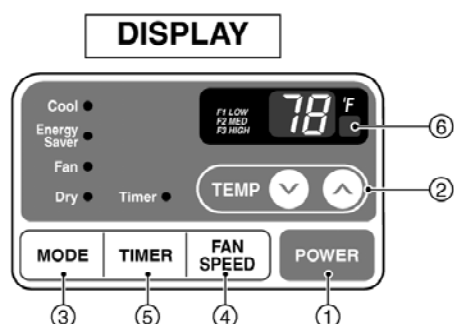

**PRECAUTION:** The Remote Control unit will not function properly if strong light strikes the sensor window of the air conditioner or if there are obstacles between the Remote Control unit and the air conditioner.

### 1 POWER BUTTON

To turn the air conditioner ON, push the button. To turn the air conditioner OFF, push the button again. This button takes priority over any other buttons.

### 2 ROOM TEMPERATURE SETTING BUTTON

This button can automatically control the temperature of the room. The temperature can be set within a range of 60°F to 86°F by 1°F. (16°C to 30°C by 1°C)  
Select the lower number for lower temperature of the room.

### 3 OPERATION MODE SELECTION BUTTON

Every time you push this button, it will shift among COOL, ENERGY SAVER, FAN and DRY.

- Energy Saver: If Energy Save mode is selected, the fan stops when the compressor stops cooling.

Approximately every 3 minutes the fan will turn on and check the room air to determine if cooling is needed.

### 4 FAN SPEED SELECTOR

Every time you push this button, it is set as follows.

(Hi [F3] → Low [F1] → Med [F2] → Hi [F3] → Low [F1] →...)

### 5 ON/OFF TIMER BUTTON

You can set the time when the unit will turn on or turn off automatically by pressing the timer button. If the unit is operating, this button controls the time it will be turned off. If the unit is off state, this button controls the time it will start. Every time you push this button, the remaining time will be set as follows.

- Stopping operation

(1Hour → 2Hours → 3Hours → 4Hours → 5Hours → 6Hours → 7Hours → 8Hours → 9Hours → 10Hours → 11Hours → 12Hours → 0Hour → 1Hour → 2Hours →...)

- Starting operation

(1Hour → 2Hours → 3Hours → 4Hours → 5Hours → 6Hours → 7Hours → 8Hours → 9Hours → 10Hours → 11Hours → 12Hours → off → 1Hour → 2Hours → ...)

### 6 REMOCON SIGNAL RECEIVER

# Disassembly

— Before the following disassembly, **CONTROL BOX** set to OFF and disconnect the power cord.

## Mechanical Parts

### 1. Front Grille

1. Open the Inlet grille downward and remove the air filter.
2. Remove the screw that fastens the front grille.(See Figure 13)
3. Pull the front grille from the right side.
4. Remove the front grille.(There are 4 hooks.)
5. Re-install the components by referring to the removal procedure, above.

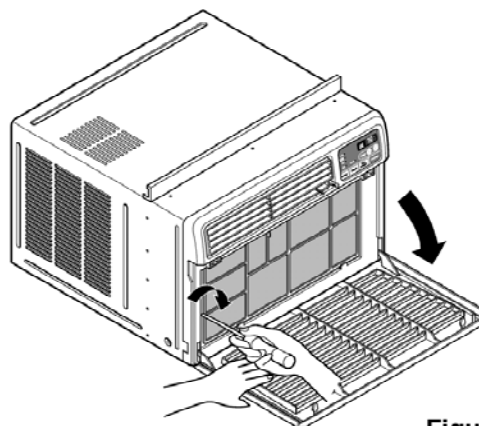

Figure 13

### 2. Cabinet

1. After disassembling the FRONT GRILLE, remove the 2 screws that fasten the cabinet at both sides.
2. Remove the 2 screws that fasten the cabinet at back.
3. Pull the base pan forward. (See Figure 14)
4. Remove the cabinet.
5. Re-install the components by referring to the removal procedure, above.

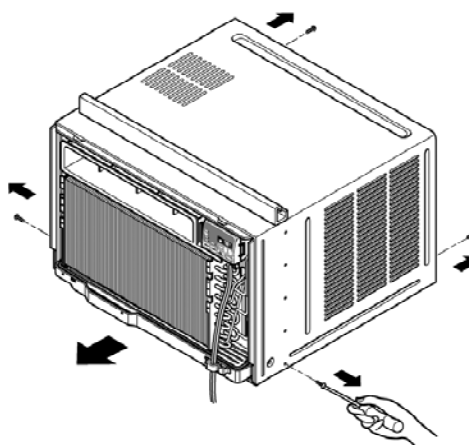

Figure 14

### 3. Control Box

1. Remove the front grille. (Refer to section 1)
2. Remove the cabinet. (Refer to section 2)
3. Remove the 2 screws which fasten the power cord.
4. Disconnect the grounding screw from the evaporator channel.
5. Remove the 1 screw that fastens the control box cover.
6. Remove the housing that connects PCB and motor wire in the control box.
7. Disconnect the housing that connects Plasma Air Purifier.(Optional)
8. Remove the screw at left cover of filter case and open the cover to remove inner screw. (Optional)
9. Remove the nut that fastens the terminal cover.
10. Remove the terminal cover.
11. Remove all the leads from the overload protector.
12. Discharge the capacitor by placing a 20,000 ohm resistor across the capacitor terminals.
13. Raise the control box upward completely. (See Figure 15)
14. Re-install the components by referring to the removal procedure, above.  
(Refer to the wiring diagram found on page 22 in this manual and on the control box.)

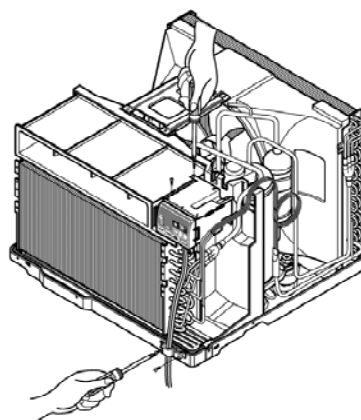

Figure 15



## Air Handling Parts

### 4. Air Guide and Turbo Fan

1. Remove the front grille. (Refer to section 1)
2. Remove the cabinet. (Refer to section 2)
3. Remove the control box. (Refer to section 3)
4. Remove the 4 screws that fasten the brace.
5. Remove the brace.
6. Remove the 2 screws that fasten the air guide upper.
7. Remove the air guide upper.(See Figure 16)
8. Remove the 2 screws that fasten the evaporator.
9. Move the evaporator forward and pulling it upward slightly. (See Figure 17)
10. Pull out the hook of orifice by pushing the tabs and remove it. (See Figure 18)
11. Remove the clamp with a hand plier that secures the turbo fan.
12. Remove the turbo fan.
13. Remove the 2 screws that fasten the air guide from the base pan.
14. Move the air guide backward, and pull out from the base pan.(Move the air guide lower carefully.)
15. Re-install the components by referring to the removal procedure, above.

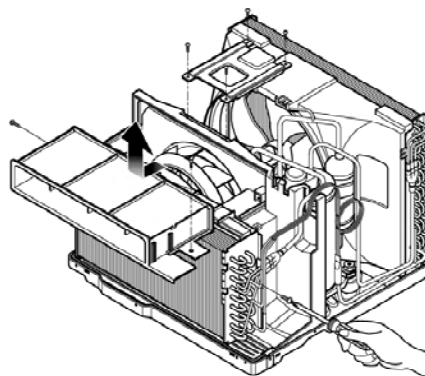

Figure 16

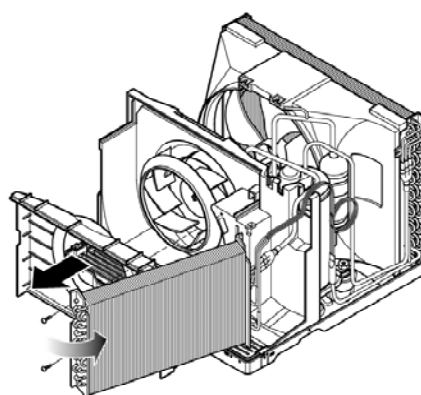

Figure 17

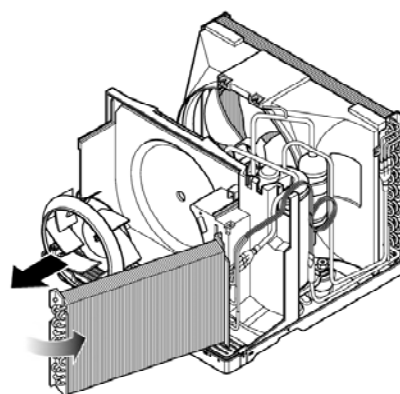

Figure 18

### 5. FAN

1. Remove the cabinet. (Refer to section 2)
2. Remove the brace (Refer to section 4)
3. Remove the 5 screws that fasten the condenser.
4. Move the condenser to the left carefully.
5. Remove the clamp that secures the fan.
6. Remove the fan. (See Figure 19)
7. Re-install by referring to the removal procedure.

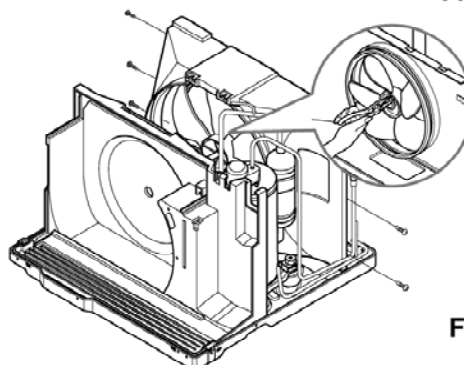

Figure 19

## 6. Shroud

1. Remove the fan. (Refer to section 5)
2. Remove the shroud. (See Figure 20)
3. Re-install the components by referring to the removal procedure, above.

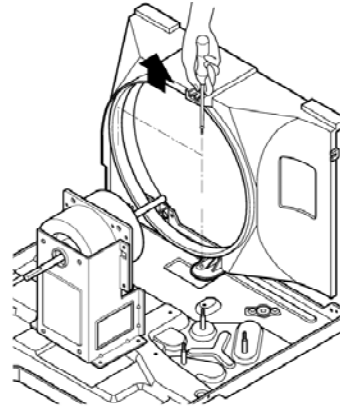

Figure 20

## Electrical Parts

### 7. Overload Protector

1. Remove the cabinet. (Refer to section 2)
2. Remove the nut that fastens the terminal cover.
3. Remove the terminal cover. (See Figure 21)
4. Remove all the leads from the overload protector.
5. Remove the overload protector.
6. Re-install the components by referring to the removal procedure, above.

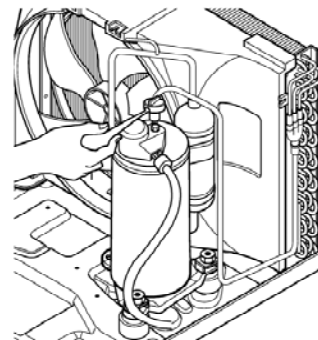

Figure 21

### 8. Compressor

1. Remove the cabinet. (Refer to section 2)
2. Discharge the refrigerant system using a Freon™ Recovery System.  
If there is no valve to attach the recovery system, install one (such as a WATCO A-1) before venting the Freon™. Leave the valve in place after servicing the system.
3. Remove the overload protector. (Refer to section 7)
4. After purging the unit completely, unbrazed the suction and discharge tubes at the compressor connections.
5. Remove the 3 nuts and the 3 washers which fasten the compressor.
6. Remove the compressor. (See Figure 22)
7. Re-install the components by referring to the removal procedure, above.

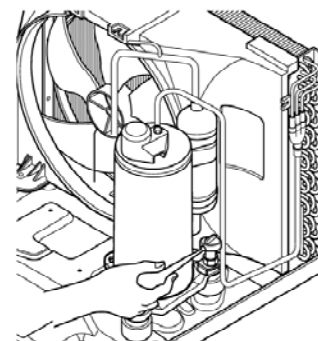

Figure 22

## 9. Capacitor

1. Remove the control box. (Refer to section 3)
2. Open the top cover from the control box. (See Figure 23)
3. Pull out the capacitor from the control box.
4. Disconnect all the leads of capacitor terminals.
5. Re-install the components by referring to the removal procedure, above.

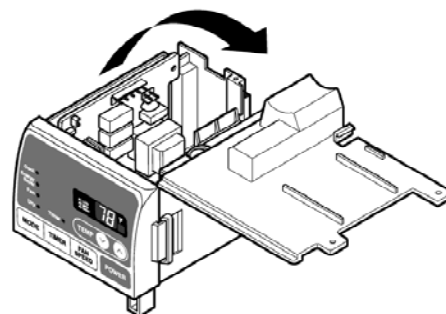

Figure 23

## 10. Power Cord

1. Remove the control box. (Refer to section 3)
2. Open the top cover from the control box. (Refer to section 9)
3. Disconnect the front panel from the control box. (See Figure 24)
4. Disconnect two leads from the capacitor and relay.
5. Pull out the power cord.
6. Re-install the component by referring to the above removal procedure, above. (Use only one ground-marked hole for ground connection.)
7. If the supply cord of this appliance is damaged, it must be replaced by the special cord. (The special cord means the cord which has the same specification marked on the supply cord attached at the unit.)

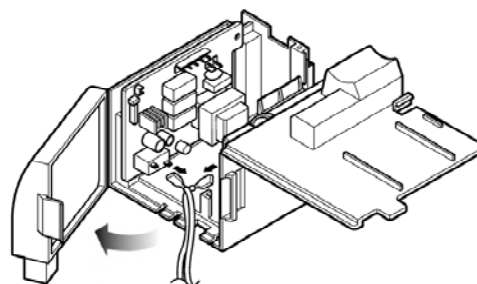
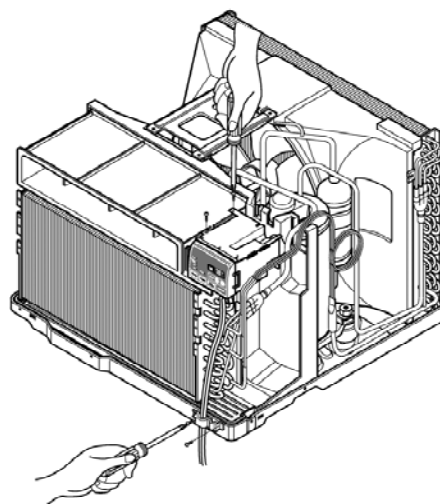

Figure 24

### 11. Motor

1. Remove the cabinet. (Refer to section 2)
2. Remove the turbo fan. (Refer to section 4)
3. Remove the fan. (Refer to section 5)
4. Remove the 4 screws that fasten the motor from the air guide. (See Figure 25)
5. Remove the motor.
6. Re-install the components by referring to the removal procedure, above.(See Figure 25)

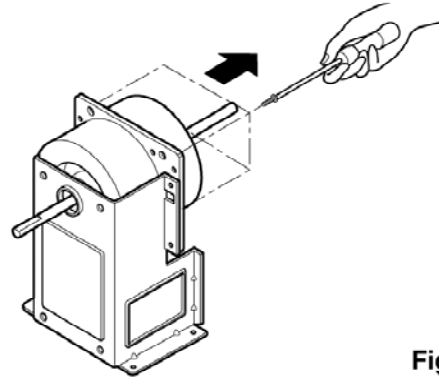

Figure 25

## Refrigerating Cycle

### 12. Condenser

**CAUTION:** Discharge the refrigerant system using a Freon™ Recovery System. If there is no valve to attach the recovery system, install one (such as a WATCO A-1) before venting the Freon™. Leave the valve in place after servicing the system.

1. Remove the cabinet. (Refer to section 2)
2. Remove the 4 screws that fasten the brace.(Refer to section 4)
3. Remove the 5 screws that fasten the condenser and shroud.
4. After discharging the refrigerant completely, unbrazed the interconnecting tube at the condenser connections.
5. Remove the condenser.
6. Re-install the components by referring to notes. (See Figure 26)

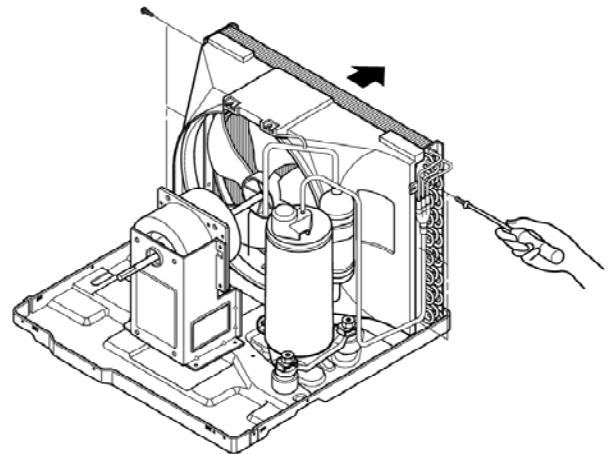

Figure 26

### 13. Evaporator

1. Remove the control box.(Refer to section 3)
2. Remove the air guide upper. (Refer to section 4)
3. Remove the 2 screws that fasten the evaporator.
4. Move the evaporator sideways carefully. (Refer to section 4)
5. After discharging the refrigerant completely, unbrazed the interconnecting tube at the evaporator connections.
6. Remove the evaporator.
7. Re-install the components by referring to notes. (See Figure 27)

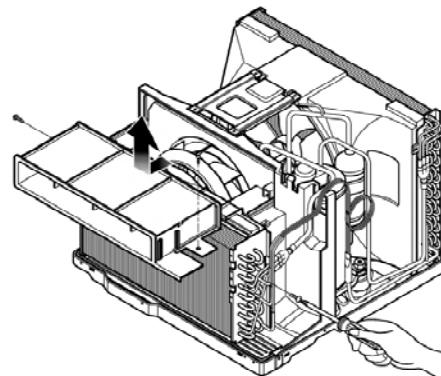

Figure 27

## 14. Capillary Tube

1. Remove the cabinet. (Refer to section s2)
2. After discharging the refrigerant completely, unbraid the interconnecting tube at the capillary tube. (See caution above)

### NOTICE

— Replacement of the refrigeration cycle.

1. When replacing the refrigeration cycle, be sure to Discharge the refrigerant system using a Freon™ recovery System.  
If there is no valve to attach the recovery system, install one (such as a WATCO A-1) before venting the Freon™. Leave the valve in place after servicing the system.
2. After discharging the unit completely, remove the desired component, and unbraid the pinch-off tubes.
3. Braid service valves into the pinch-off tube ports, leaving the valves open.
4. Braid the pinch-off tubes with Service valves.
5. Evacuate as follows.
  - 1) Connect the vacuum pump, as illustrated figure 28A.
  - 2) Start the vacuum pump, slowly open manifold valves A and B with two full turns counterclockwise and leave the valves open.  
The vacuum pump is now pulling through valves A and B up to valve C by means of the manifold and entire system.

**CAUTION:** If high vacuum equipment is used, just crack valves A and B for a few minutes, then open slowly with the two full turns counterclockwise. This will keep oil from foaming and being drawn into the vacuum pump.

- 3) Operate the vacuum pump vacuum for 20 to 30 minutes, until 600 microns of vacuum is obtained. Close valves A and B, and observe vacuum gauge for a few minutes. A rise in pressure would indicate a possible leak or moisture remaining in the system. With valves A and B closed, stop the vacuum pump.
- 4) Remove the hose from the vacuum pump and place it on the charging cylinder. See figure 28B.  
Open valve C.  
Discharge the line at the manifold connection.
- 5) The system is now ready for final charging.

3. Remove the capillary tube.
4. Re-install the components by referring to notes.

6. Recharge as follows :
  - 1) Refrigeration cycle systems are charged from the High-side. If the total charge cannot be put in the High-side, the balance will be put in the suction line through the access valve which you installed as the system was opened.
  - 2) Connect the charging cylinder as shown in figure 28B.  
With valve C open, discharge the hose at the manifold connection.
  - 3) Open valve A and allow the proper charge to enter the system. Valve B is still closed.
  - 4) If more charge is required, the high-side will not take it. Close valve A.
  - 5) With the unit running, open valve B and add the balance of the charge.
    - a. Do not add the liquid refrigerant to the Low-side.
    - b. Watch the Low-side gauge; allow pressure to rise to 30 lbs.
    - c. Turn off valve B and allow pressure to drop.
    - d. Repeat steps b. and c. until the balance of the charge is in the system.
  - 6) When satisfied the unit is operating correctly, use the pinch-off tool with the unit still running and clamp on to the pinch-off tube. Using a tube cutter, cut the pinch-off tube about 2 inches from the pinch-off tool. Use sil-fos brazing and braid pinch-off tube closed. Turn off the unit, allow it to set for a while, and then test the leakage of the pinch-off connection.

Disassembly

**Equipment needed:** Vacuum pump, Charging cylinder, Manifold gauge, Brazing equipment. Pin-off tool capable of making a vapor-proof seal, Leak detector, Tubing cutter, Hand Tools to remove components, Service valve.

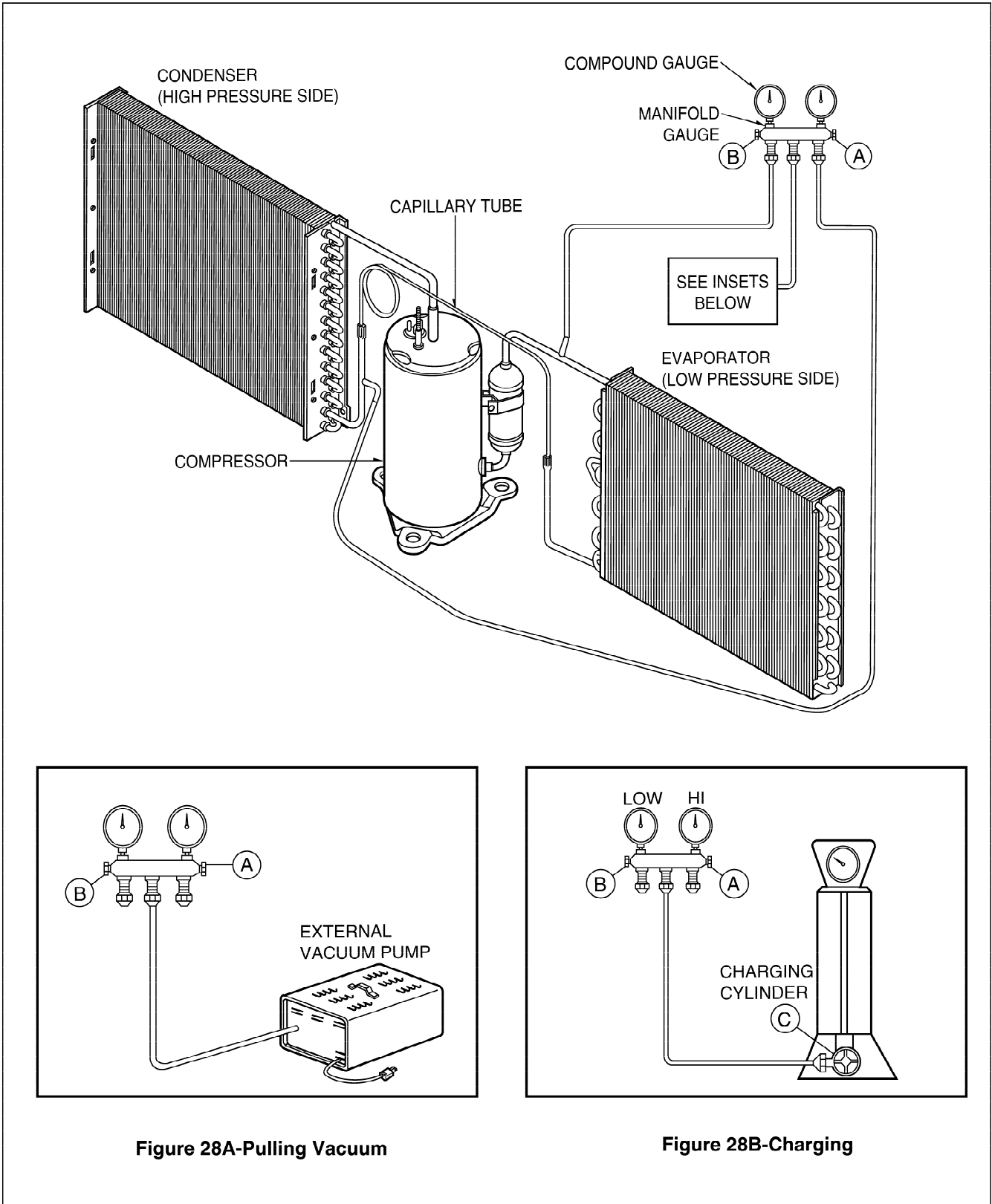

# Schematic Diagram

## Electronic Control Device

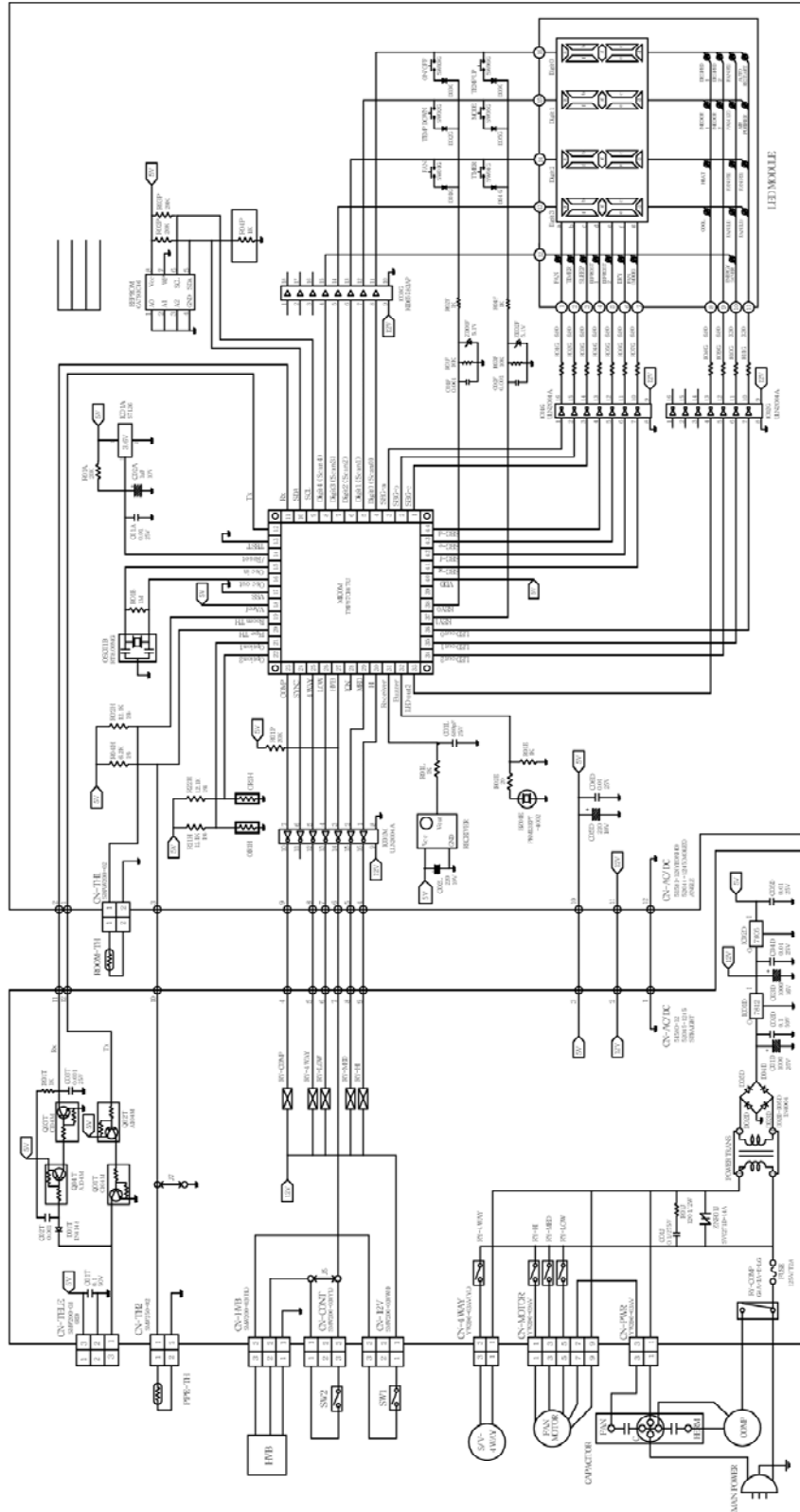

**Wiring Diagram**

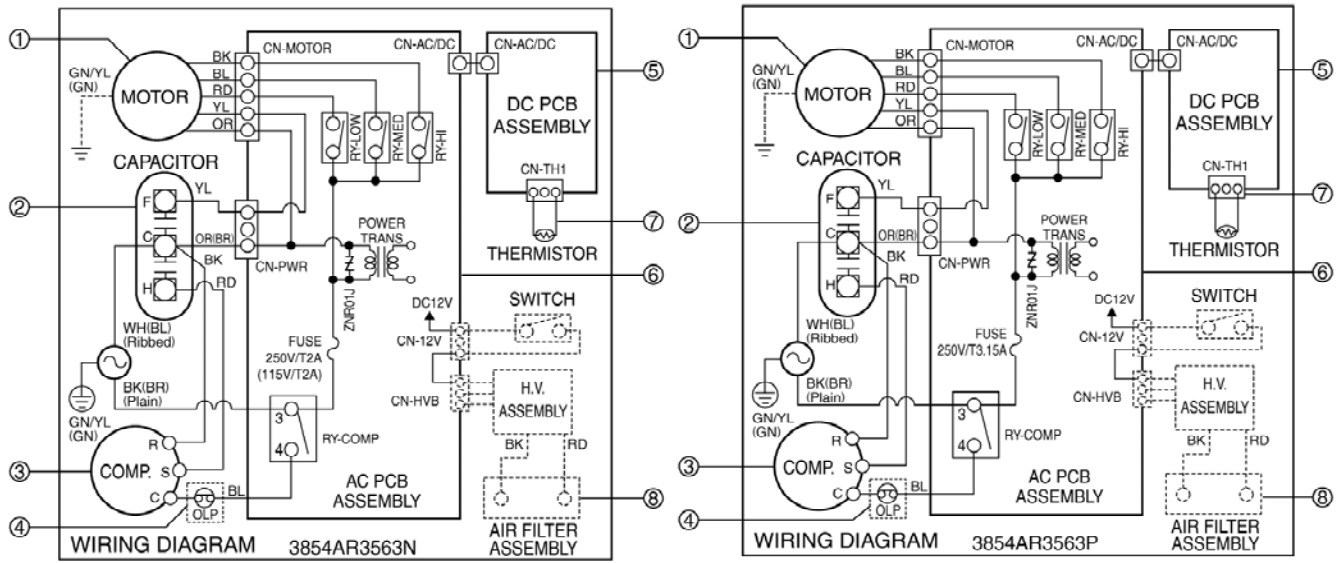

S: Service Parts  
N: Non Service Parts

LOCATION NO.	DESCRIPTION	Q'TY PER SET	REMARKS
1	MOTOR ASSY	1	S
2	CAPACITOR	1	S
3	COMPRESSOR	1	S
4	OVERLOAD PROTECTOR	1	S
5	DC PCB ASSEMBLY	1	S
6	AC PCB ASSEMBLY	1	S
7	THERMISTOR	1	S
8	PLASMA FILTER ASSY	1	S



# Components Location

## 1. MAIN P.C.B ASSEMBLY

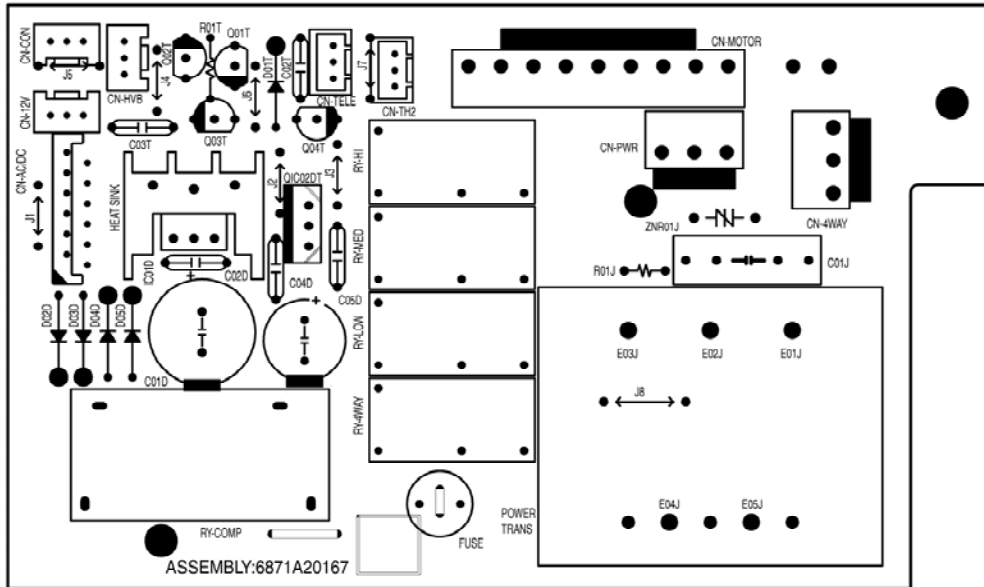

## 2. DISPLAY P.C.B. ASSEMBLY

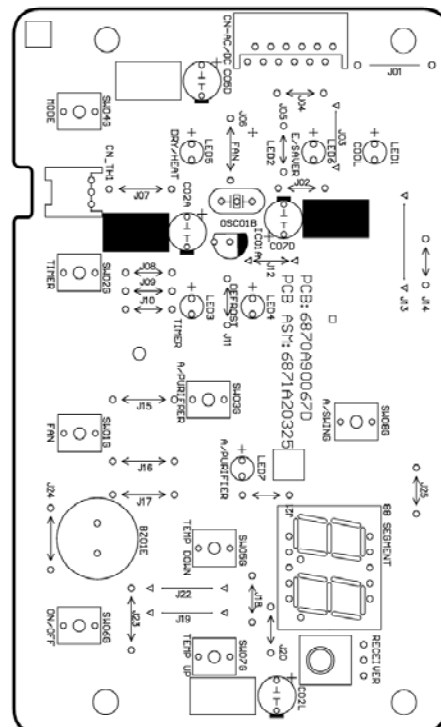
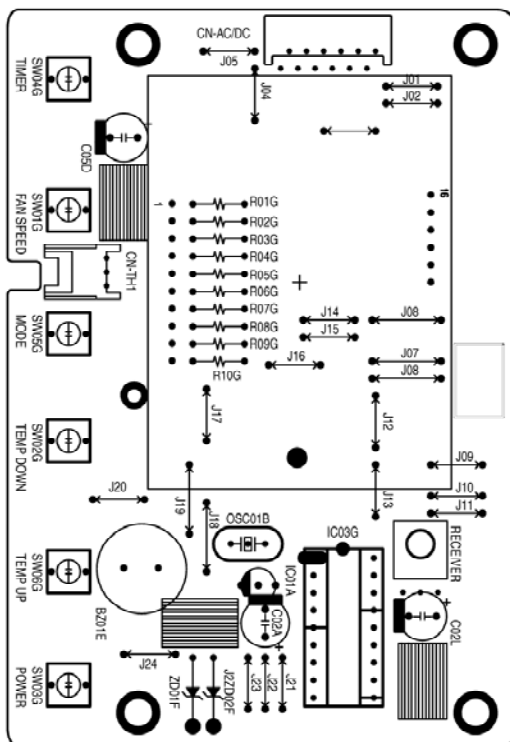

# Troubleshooting Guide

## Piping System

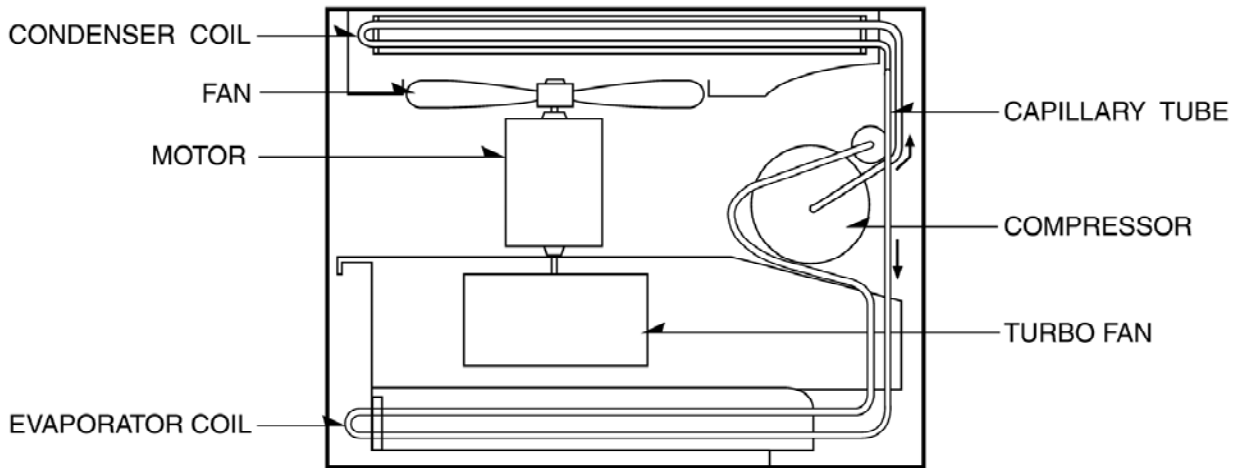
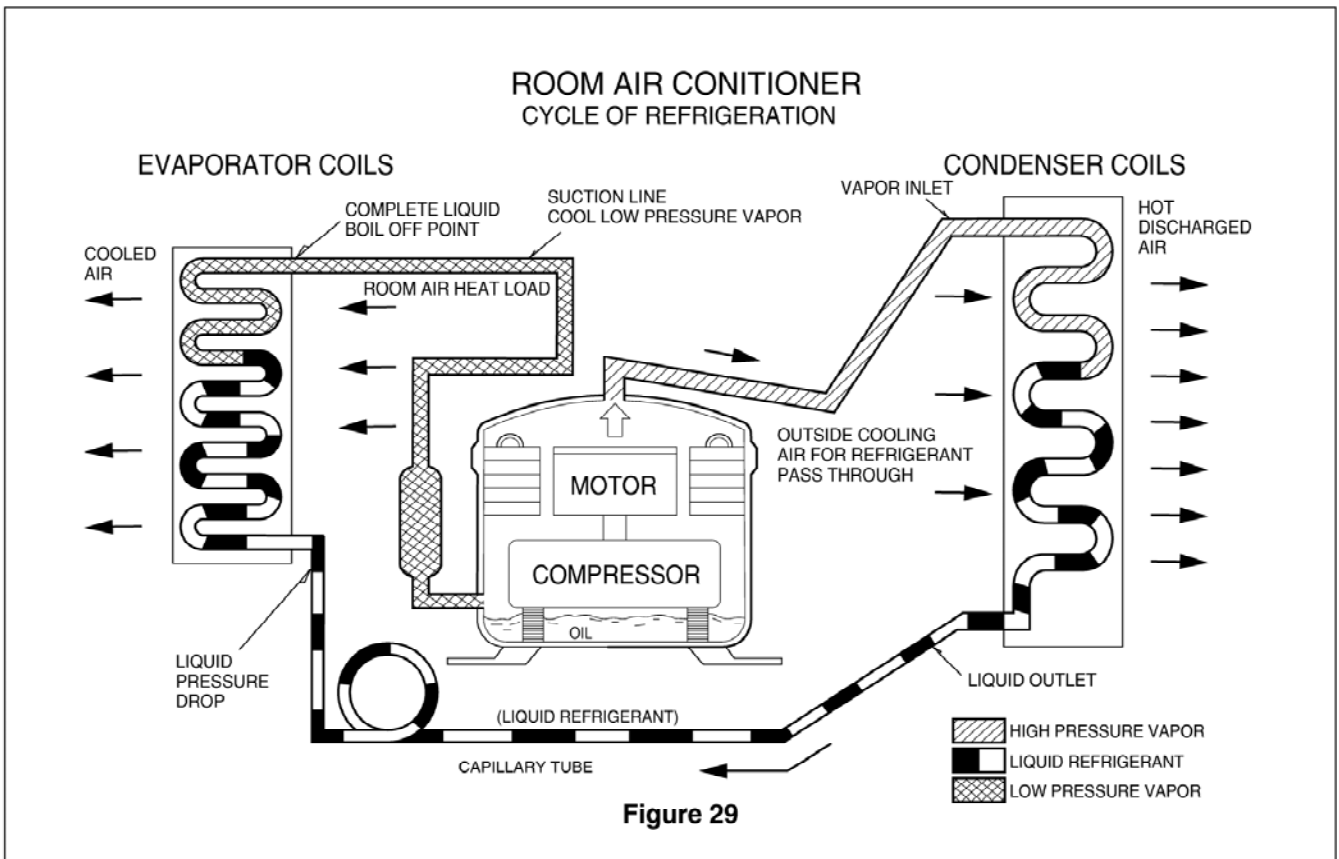

Figure 29 is a brief description of the important components and their function in what is called the refrigeration system. This will help you to understand the refrigeration cycle and the flow of the refrigerant in the cooling cycle.



## Troubleshooting Guide

In general, possible trouble is classified in two kinds.

The one is called Starting Failure which is caused from an electrical defect, and the other is ineffective Air Conditioning caused by a defect in the refrigeration circuit and improper application.

### Unit runs but poor cooling.

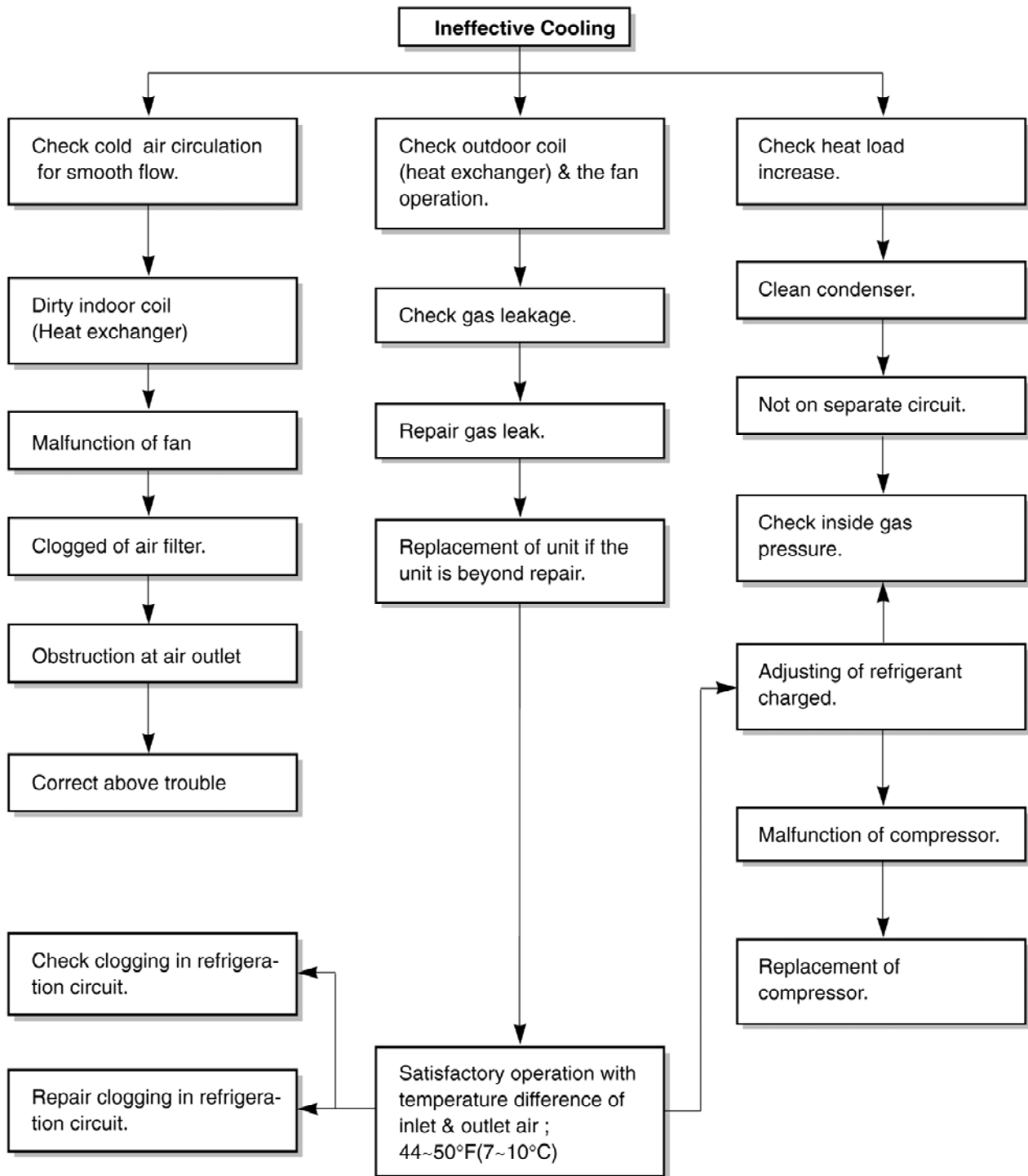

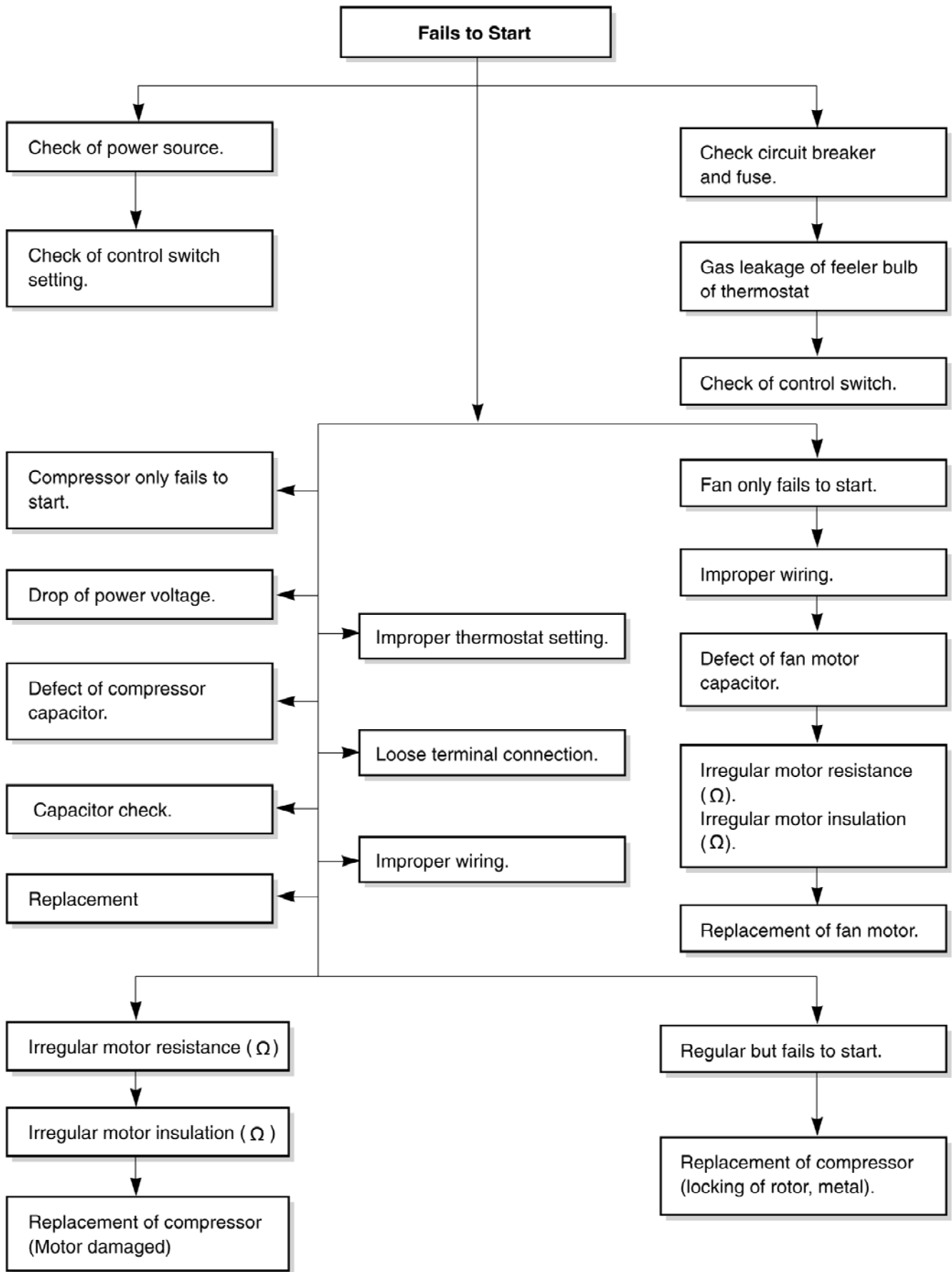

# Electrical Parts Troubleshooting Guide

**Possible Trouble 1**

The unit does not operate.

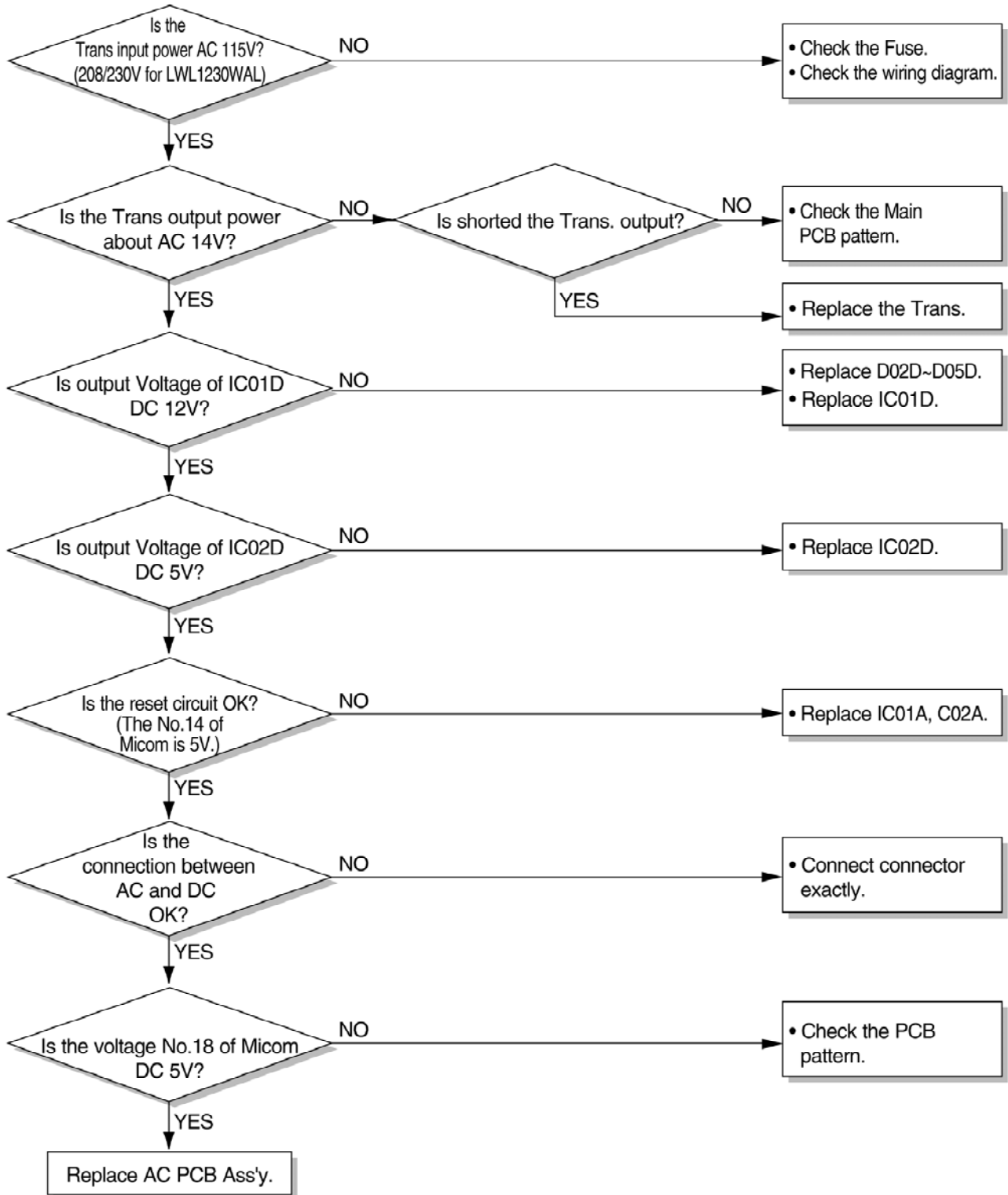

**Possible Trouble 2** The compressor does not operate.

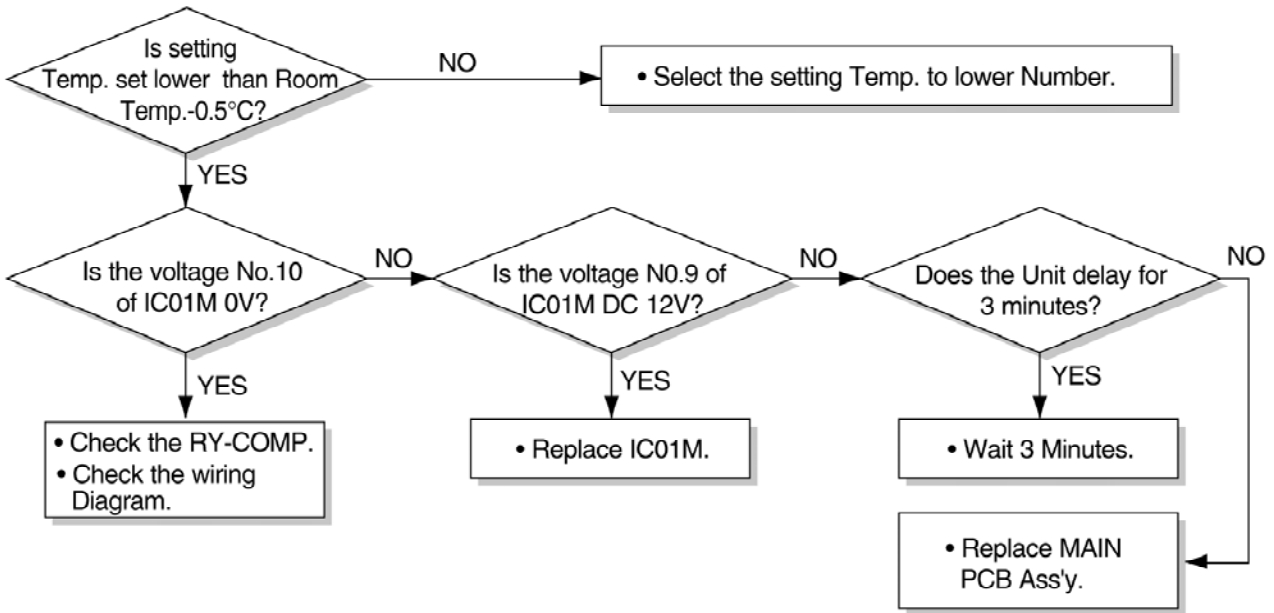

**Possible Trouble 3** The compressor always operate.



**Possible Trouble 4**

FAN does not operate.

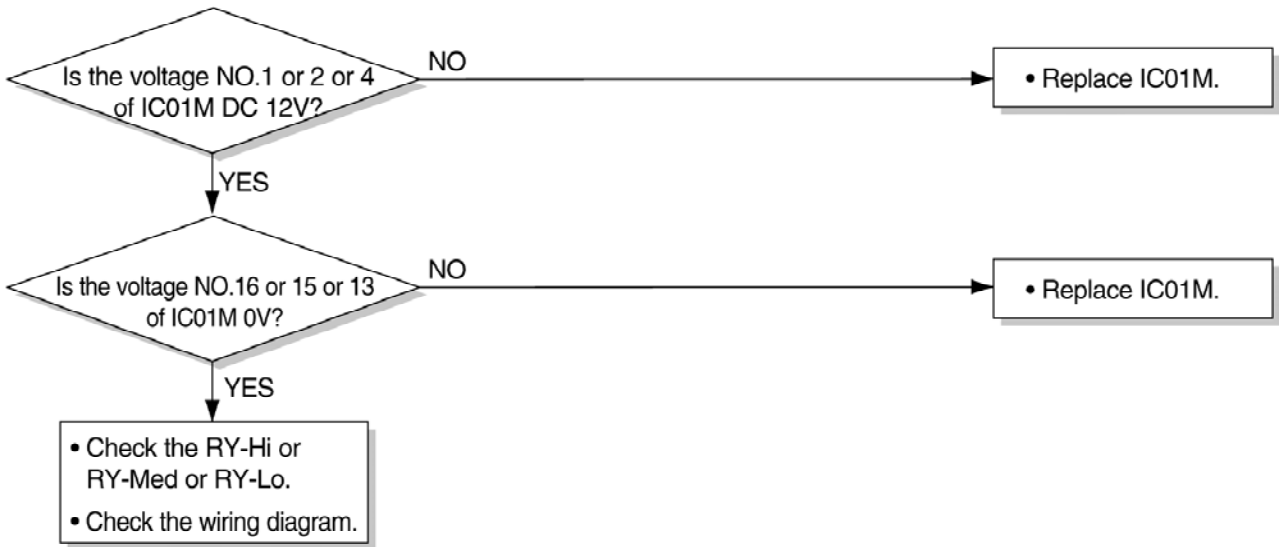

**Possible Trouble 5**

The function of Energy Saver does not operate.

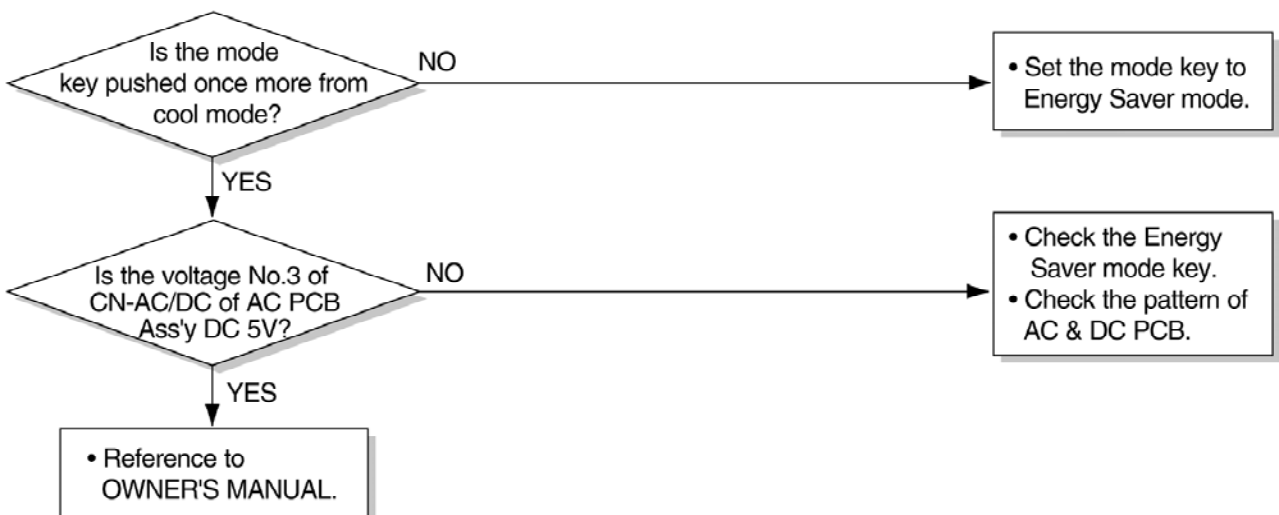

**Possible Trouble 6**

Remote controller does not operate.

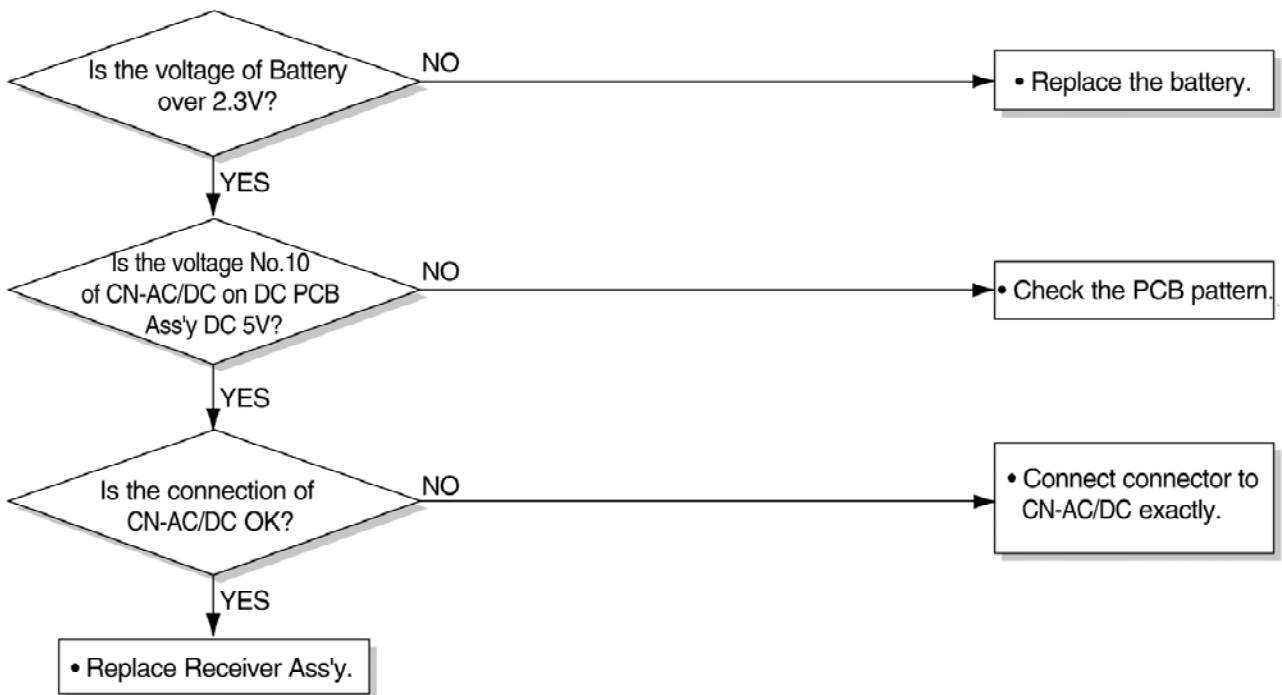

**Possible Trouble 7**

It displays abnormally on DC PCB Ass'y.

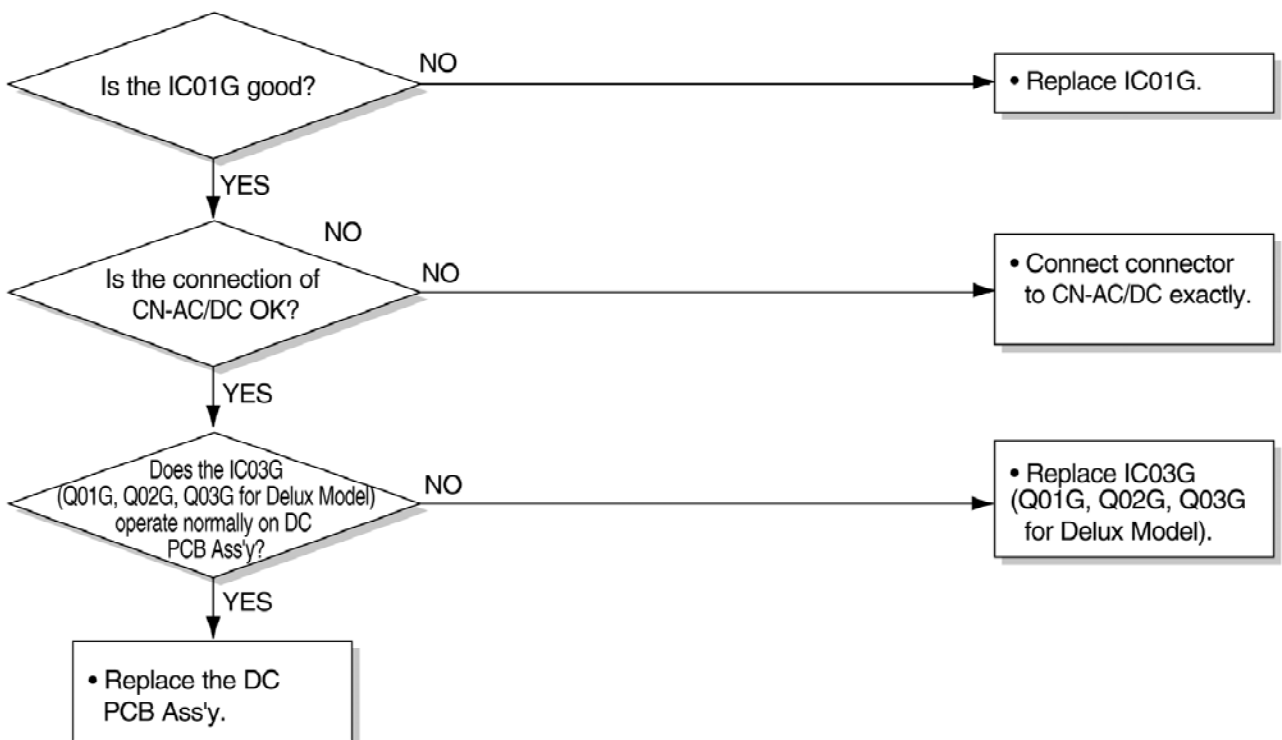



## Electric Parts

### Possible Trouble 1

The unit does not operate.

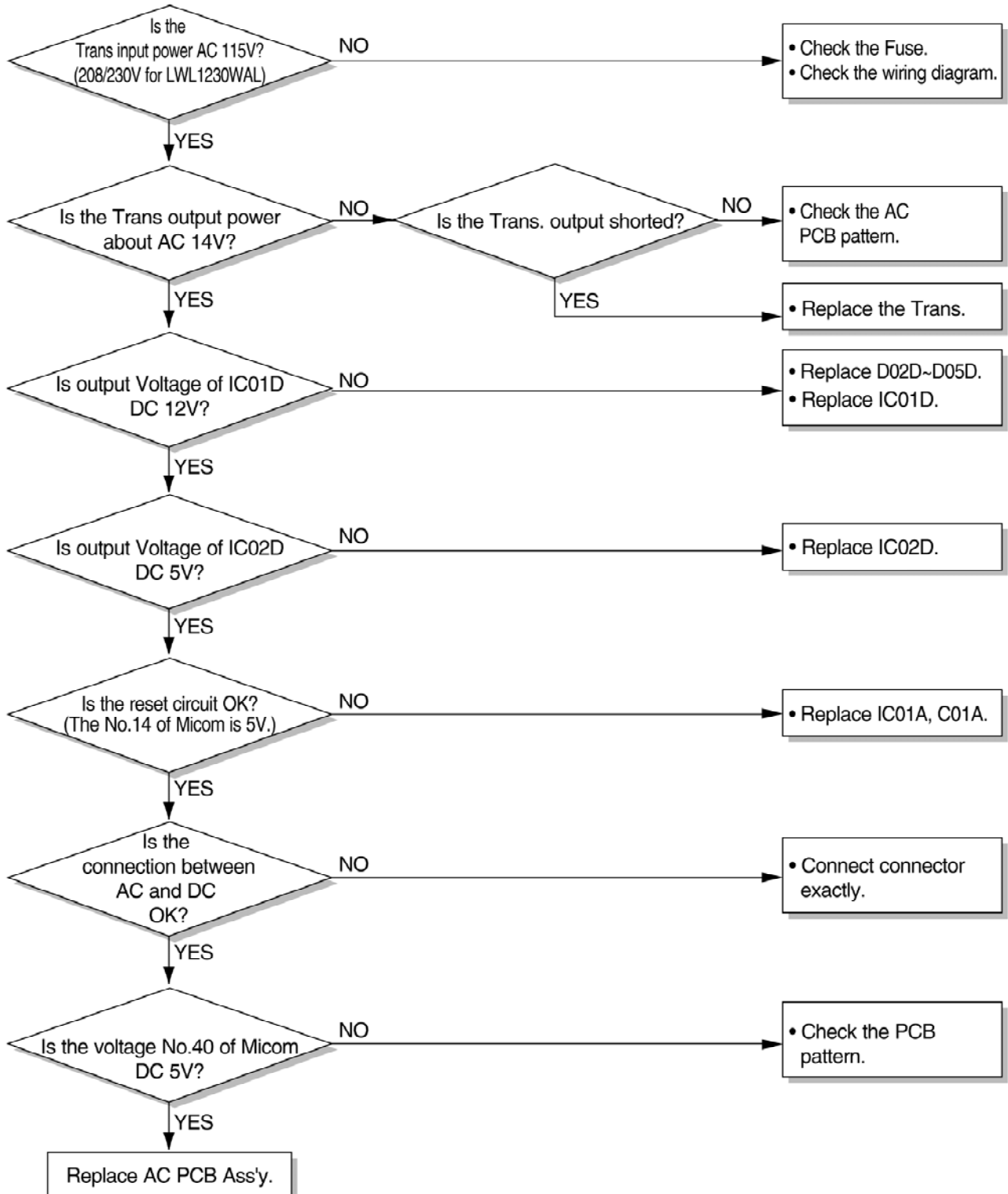

**Possible Trouble 2**

The compressor does not operate.

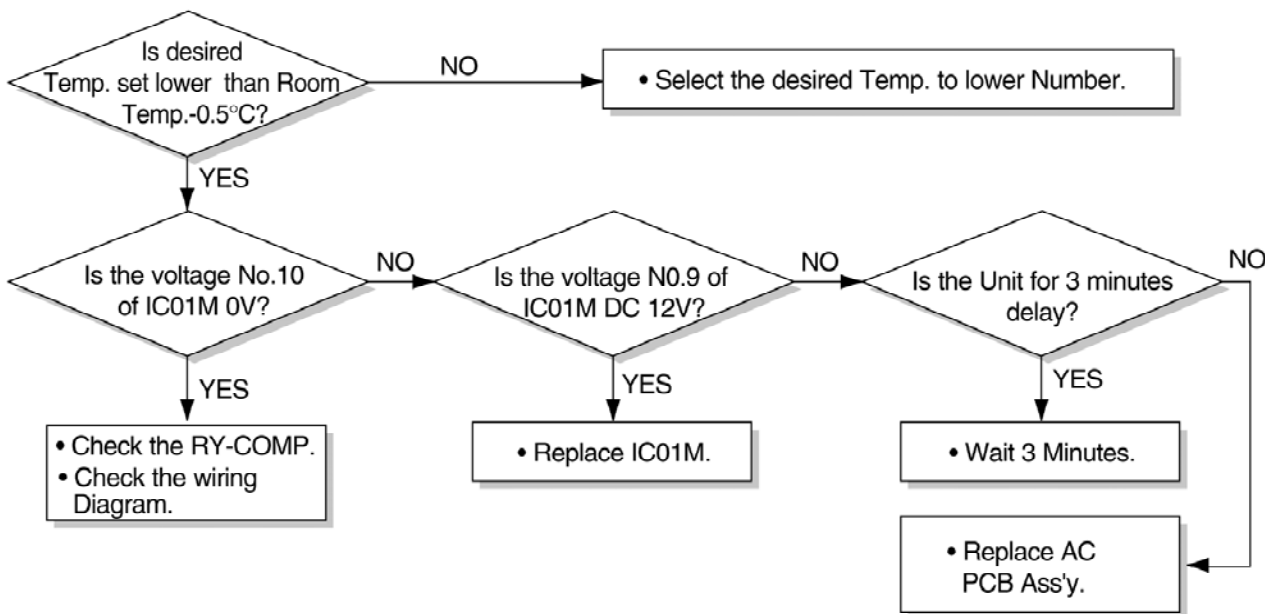

**Possible Trouble 3**

The compressor always operate.



**Possible Trouble 4** FAN does not operate.

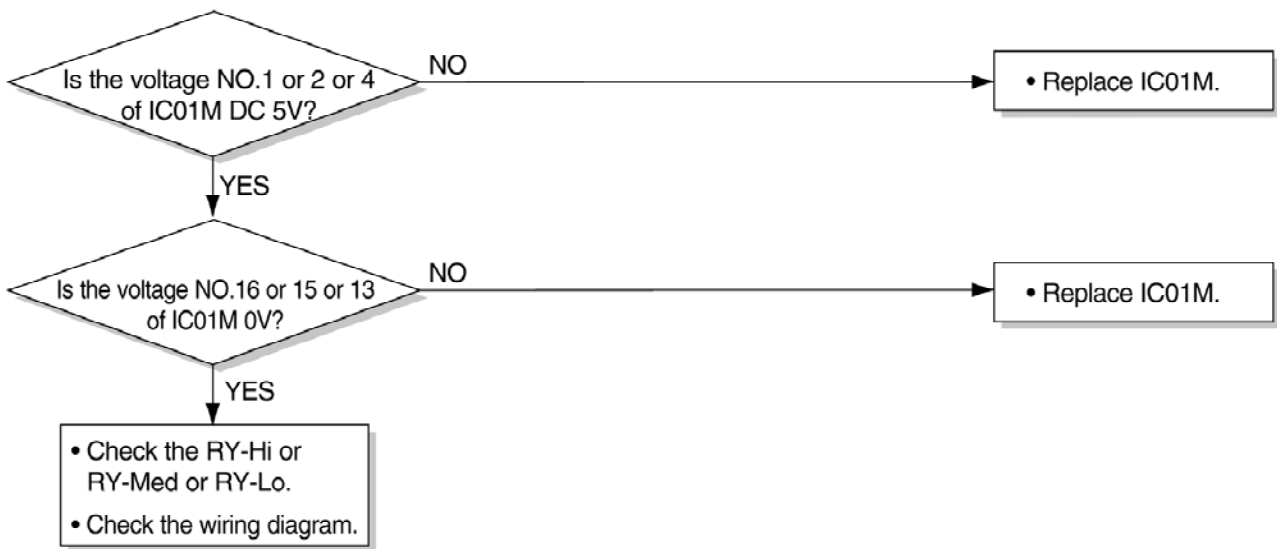

**Possible Trouble 5** Remote controller does not operate.

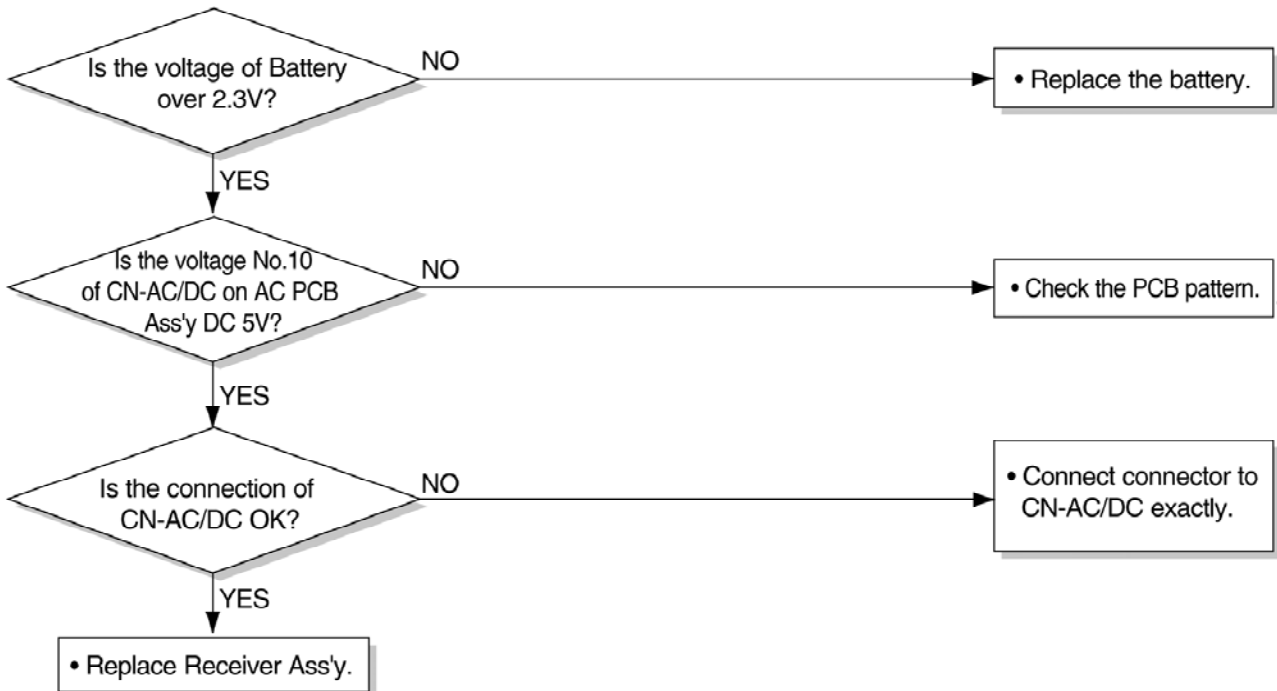

**Possible Trouble 6**

It displays abnormally on DC PCB Ass'y.

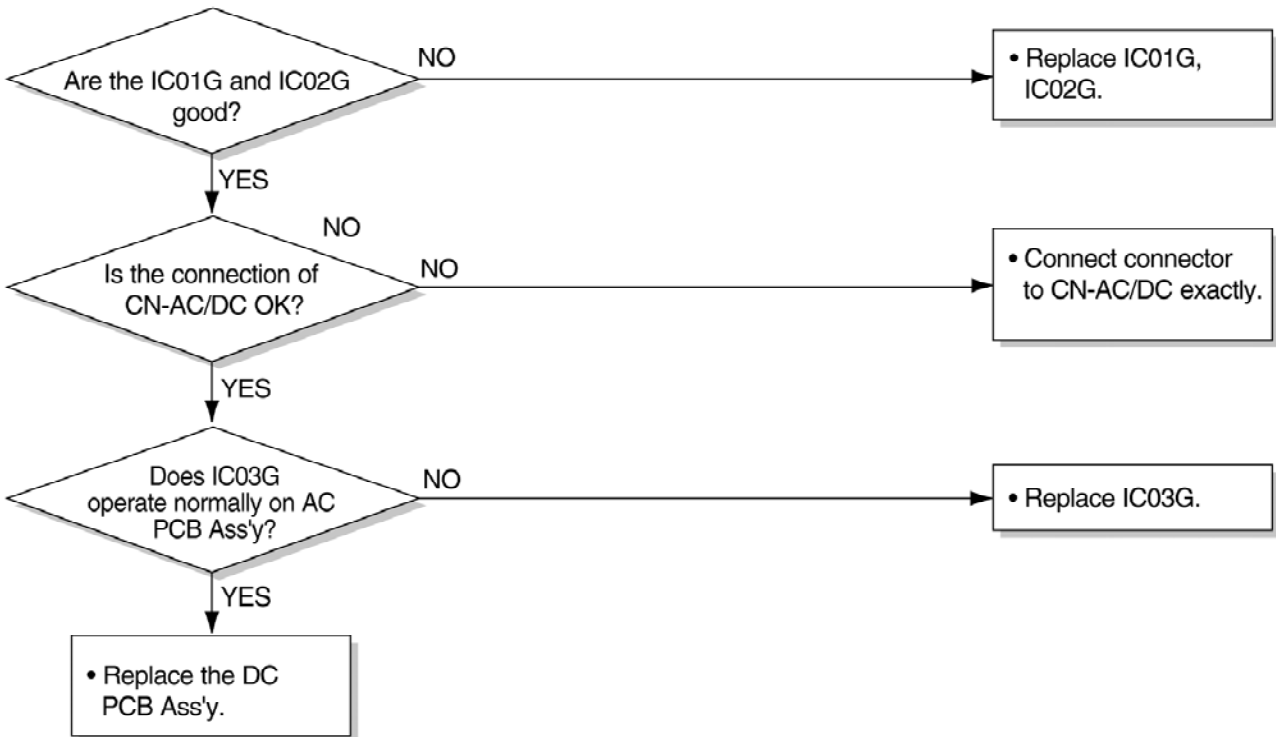

COMPLAINT	CAUSE	REMEDY
Fan motor will not run.	No power	Check voltage at outlet. Correct if none.
	Power supply cord	Check voltage to Control Box. If none, check power supply cord. Replace cord if circuit is open.
	Wire disconnected or connection loose	Connect wire. Refer to wiring diagram for terminal identification. Repair or replace loose terminal.
	Capacitor (Discharge capacitor before testing.)	Test capacitor. Replace if not within $\pm 10\%$ of manufacturer's rating. Replace if shorted, open, or damaged.
	Will not rotate	Fan blade hitting shroud or blower wheel hitting scroll. Realign assembly.  Units using slinger ring for condenser fan must have $\frac{1}{4}$ to $\frac{5}{16}$ inch clearance to the base. If it hits the base, shim up the bottom of the fan motor with mounting screw(s).  Check fan motor bearings; if motor shaft will not rotate, replace the motor.
Fan motor runs intermittently	Revolves on overload.	Check voltage. If not within limits, call an electrician.  Test capacitor. Check bearings. Does the fan blade rotate freely? If not, replace fan motor.  Pay attention to any change from high speed to low speed. If the speed does not change, replace the motor.
Fan motor noise.	Fan	If cracked, out of balance, or partially missing, replace it.
	Turbo	If cracked, out of balance, or partially missing, replace it.
	Loose clamper	Tighten it.
	Worn bearings	If knocking sounds continue when running or loose, replace the motor. If the motor hums or noise appears to be internal while running, replace motor.
Compressor will not run, but fan motor runs.	Voltage	Check voltage. If not within limits, call an electrician.
	Wiring	Check the wire connections, if loose, repair or replace the terminal. If wires are off, refer to wiring diagram for identification, and replace. Check wire locations. If not per wiring diagram, correct.

COMPLAINT	CAUSE	REMEDY
Compressor will not run, but fan motor runs.	Thermistor	Check the TEMP control. If not at the lowest number, set TEMP control to this setting and restart the unit. Check the continuity of the thermistor. Replace the thermistor if the circuit is open.
	Capacitor (Discharge capacitor before servicing.)	Check the capacitor. Replace if not within $\pm 10\%$ of manufacturers rating. Replace if shorted, open, or damaged.
	Compressor	Check the compressor for open circuit or ground. If open or grounded, replace the compressor.
	Overload	Check the compressor overload, if externally mounted. Replace if open. (If the compressor temperature is high, remove the overload, cool it, and retest.)
Compressor cycles on overload.	Voltage	Check the voltage. If not within limits, call an electrician.
	Overload	Check overload, if externally mounted. Replace if open. (If the compressor temperature is high, remove the overload, cool, and retest.)
Compressor cycles on overload.	Fan motor	If not running, determine the cause. Replace if required.
	Condenser air flow restriction	Remove the cabinet. inspect the interior surface of the condenser; if restricted, clean carefully with a vacuum cleaner (do not damage fins) or brush. Clean the interior base before reassembling.
	Condenser fins (damaged)	If condenser fins are closed over a large area on the coil surface, head pressures will increase, causing the compressor to overload. Straighten the fins or replace the coil.
Compressor cycles on overload.	Capacitor	Test capacitor.
	Wiring	Check the terminals. If loose, repair or replace.
	Refrigerating system	Check the system for a restriction.
Insufficient cooling or heating	Air filter	If restricted, clean or replace.
	Exhaust damper door	Close if open.
	Unit undersized	Determine if the unit is properly sized for the area to be cooled.
Excessive noise	Turbo or fan	Check the set screw or clamp. If loose or missing, correct. If the turbo or fan is hitting air guide, rearrange the air handling parts.
	Copper tubing	Remove the cabinet carefully and rearrange tubing not to contact cabinet, compressor, shroud, and barrier.

# Exploded View

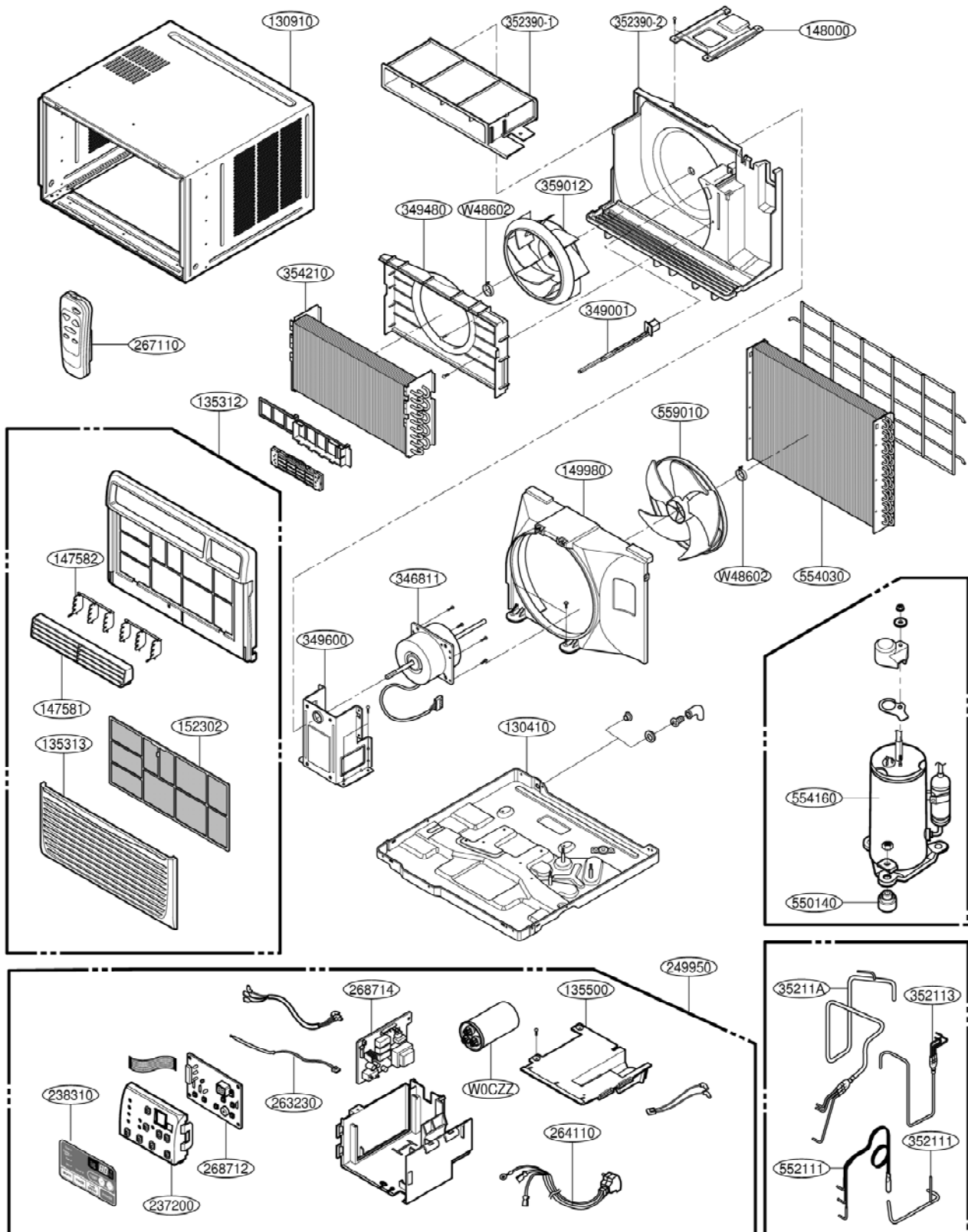

# Replacement Parts List

LOCATION NO.	DESCRIPTION	PART NO.			REMARK
		HBLG2504E	LW250CE	LWHD2500ER	
130410	BASE ASSEMBLY,SINGLE	3041A10050B	3041A10050B	3041A10050B	R
130910	CABINET ASSEMBLY,SINGLE	3091A10064A	3091A10064A	3091A10064A	R
135312	GRILLE ASSEMBLY,FRONT(SINGLE)	3531A24013A	3531A24013A	3531A24013B	R
135313	GRILLE,INLET	3530A10210A	3530A10210A	3530A10210A	R
135500	COVER	3550A30122B	3550A30122B	3550A30122B	R
147581	LOUVER,HORIZONTAL	4758A30022A	4758A30022A	4758A30022A	R
147582	LOUVER,VERTICAL	4758A20042A/B	4758A20042A/B	4758A20042A/B	R
148000	BRACE	4800A20001A	4800A20001A	4800A20001A	R
149980	SHROUD	4998A10035A	4998A10035A	4998A10035A	R
152302	FILTER ASSEMBLY,AIR CLEANER	5231A20027A	5231A20027A	5231A20027A	R
237200	PANEL,CONTROL	3720A10112A	3720A10112A	3720A10112A	R
238310	ESCUTCHEON	3831A10021F	3831A10021K	3831A10021F	R
249950	CONTROL BOX ASSEMBLY,SINGLE	4995A30010R	4995A30010Y	4995A10133D	R
263230	THERMISTOR ASSEMBLY	6323A20004E	6323A20004E	6323A20004E	R
264110	POWER CORD ASSEMBLY	6411A20011A	6411A20011A	6411A20048L	R
267110	REMOTE CONTROLLER ASSEMBLY	6711A90019C	6711A20034G	6711A20034G	R
268712	PWB(PCB) ASSEMBLY,MAIN(DC)	6871A20325A	6871A20325A	6871A20325A	R
268714	PWB(PCB) ASSEMBLY,MAIN(AC)	6871A20167D	6871A20167D	6871A20167D	R
346811	MOTOR ASSEMBLY,SINGLE	4681A20043K	4681A20043K	4681A20043K	R
349001	DAMPER,VENTILATION	4900A20016A	4900A20016A	4900A20016A	R
349480	ORIFICE	4948A10024A	4948A10024A	4948A10024A	R
349600	MOUNT,MOTOR	4960A20056A	4960A20056A	4960A20056A	R
352111	TUBE ASSEMBLY,FORMED COND	5211A12004A	5211A12004A	5211A12004A	R
352113	TUBE ASSEMBLY,DISCHARGE SINGLE	5211A12003A	5211A12003A	5211A12003E	R
35211A	TUBE ASSEMBLY,SUCTION SINGLE	5211A12002A	5211A12002A	5211A12002E	R
352390-1	AIR GUIDE ASSEMBLY	5239A20017A	5239A20017A	5239A20017A	R
352390-2	AIR GUIDE ASSEMBLY	5239A20020A	5239A20020A	5239A20020A	R
354210	EVAPORATOR ASSEMBLY,FIRST	5421A20186A	5421A20186A	5421A20186A	R
359012	FAN,TURBO	5900A20045B	5900A20045B	5900A20045B	R
550140	ISOLATOR,COMP	5014A20003A	5014A20003A	5014A20003A	R
552111	TUBE ASSEMBLY,CAPILLARY	5211A22014A	5211A22014A	5211A22014D	R
554030	CONDENSER ASSEMBLY,FIRST	5403A20182A	5403A20182A	5403A20182A	R
554160	COMPRESSOR	5416A20045A	5416A20045A	5416A20047A	R
359011	FAN,AXIAL	5900A10011A	5900A10011A	5900A10011A	R
W0CZZ	CAPACITOR,DRAWING	0CZZA20007A	0CZZA20007A	0CZZA20007T	R
W48602	CLAMP,SPRING	3H02932C	3H02932C	3H02932C	R



LOCATION NO.	DESCRIPTION	PART NO.	REMARK
		LW240CE	
130410	BASE ASSEMBLY,SINGLE	3041A10050B	R
130910	CABINET ASSEMBLY,SINGLE	3091A10064A	R
135312	GRILLE ASSEMBLY,FRONT(SINGLE)	3531A24013D	R
135313	GRILLE,INLET	3530A10210A	R
135500	COVER	3550A30048C	R
147581	LOUVER,HORIZONTAL	4758A30022A	R
147582	LOUVER,VERTICAL	4758A20042A/B	R
148000	BRACE	4800A20001A	R
149980	SHROUD	4998A10035A	R
152302	FILTER ASSEMBLY,AIR CLEANER	5231A20027A	R
237200	PANEL,CONTROL	3720A10112A	R
238310	ESCUTCHEON	3831A10021K	R
249950	CONTROL BOX ASSEMBLY,SINGLE	4995A30010Y	R
263230	THERMISTOR ASSEMBLY	6323A20004E	R
264110	POWER CORD ASSEMBLY	6411A20011A	R
267110	REMOTE CONTROLLER ASSEMBLY	6711A90024G	R
268712	PWB(PCB) ASSEMBLY,MAIN(DC)	6871A20325B	R
268714	PWB(PCB) ASSEMBLY,MAIN(AC)	6871A20167D	R
346811	MOTOR ASSEMBLY,SINGLE	4681A20043K	R
349001	DAMPER,VENTILATION	4900A20016A	R
349480	ORIFICE	4948A10024A	R
349600	MOUNT,MOTOR	4960A20056A	R
352111	TUBE ASSEMBLY,FORMED COND	5211A12004A	R
352113	TUBE ASSEMBLY,DISCHARGE SINGLE	5211A12003A	R
35211A	TUBE ASSEMBLY,SUCTION SINGLE	5211A12002A	R
352390-1	AIR GUIDE ASSEMBLY	5239A20017A	R
352390-2	AIR GUIDE ASSEMBLY	5239A20020A	R
354210	EVAPORATOR ASSEMBLY,FIRST	5421A20186A	R
359012	FAN,TURBO	5900A20045B	R
550140	ISOLATOR,COMP	5014A20003A	R
552111	TUBE ASSEMBLY,CAPILLARY	5211A22014E	R
554030	CONDENSER ASSEMBLY,FIRST	5403A20182A	R
554160	COMPRESSOR	5416A20045A	R
559011	FAN,AXIAL	5900A10011A	R
W0CZZ	CAPACITOR,DRAWING	0CZZA20007A	R
W48602	CLAMP,SPRING	3H02932C	R



