

GoldStar

website <http://biz.LGservice.com>

e-mail <http://www.LGService.com/techsup.html>

ROOM AIR CONDITIONER SERVICE MANUAL

CAUTION

- BEFORE SERVICING THE UNIT,
READ THE SAFETY PRECAUTIONS IN THIS MANUAL.
- ONLY FOR AUTHORIZED SERVICE

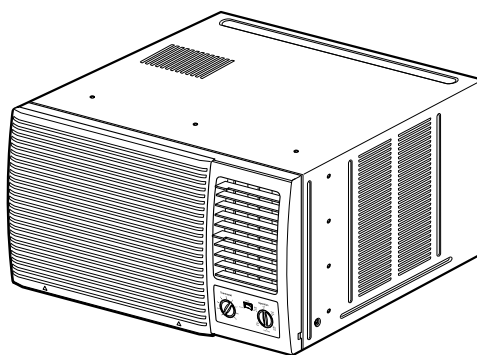

**MODELS: R1402/R1802/R1801H/M1802/R2102/R2402
R1803/R1804/R1803H/M1803R/R2103/R2403
LWM1836BCG/LWM1836BAG/LWM1836BAS/LWC243NSAB0
Y5USC18-6A/Y5USC24-6A/LWN2432BCG/LWN2432BAG**

CONTENTS

1. PREFACE

1.1 SAFETY PRECAUTIONS	2
1.2 INSULATION RESISTANCE TEST.....	2
1.3 SPECIFICATIONS	3
1.4 FEATURES	7
1.5 CONTROL LOCATIONS.....	7

2. DISASSEMBLY INSTRUCTIONS

2.1 MECHANICAL PARTS.....	10
2.1.1 FRONT GRILLE	10
2.1.2 CABINET.....	10
2.1.3 CONTROL BOX	10
2.2 AIR HANDLING PARTS.....	11
2.2.1 COVER (AT THE TOP).....	11
2.2.2 BLOWER.....	11
2.2.3 FAN	12
2.2.4 SHROUD.....	12
2.3 ELECTRICAL PARTS	12
2.3.1 MOTOR.....	12
2.3.2 COMPRESSOR	12
2.3.3 CAPACITOR	13
2.3.4 POWER CORD	13
2.3.5 THERMOSTAT	13
2.3.6 ROTARY SWITCH.....	14
2.3.7 SYNCHRONOUS MOTOR	14

2.4 REFRIGERATION CYCLE.....	15
2.4.1 CONDENSER	15
2.4.2 EVAPORATOR	15
2.4.3 CAPILLARY TUBE.....	15

3. INSTALLATION

3.1 HOW TO INSTALL THE UNIT	18
3.2 HOW TO USE THE REVERSIBLE INLET GRILLE	18
3.3 WINDOW REQUIREMENTS.....	19
3.4 INSTALLATION KITS CONTENTS.....	19
3.5 SUGGESTED TOOL REQUIREMENTS.....	20
3.6 CABINET INSTALLATION	21

4. TROUBLESHOOTING GUIDE

4.1 OUTSIDE DIMENSIONS.....	23
4.2 PIPING SYSTEM	23
4.3 TROUBLESHOOTING GUIDE.....	24

5. SCHEMATIC DIAGRAM

5.1 CIRCUIT DIAGRAM.....	29
5.2 ELECTRONIC CONTROL DEVICE	34
5.3 COMPONENTS LOCATION(FOR MAIN P.C.B ASM).....	36
5.4 COMPONENTS LOCATION(FOR DISPLAY P.C.B ASM).....	37

6. EXPLODED VIEW

7. REPLACEMENT PARTS LIST

1. PREFACE

This SERVICE MANUAL provides various service information, including the mechanical and electrical parts etc. This room air conditioner was manufactured and assembled under a strict quality control system. The refrigerant is charged at the factory. Be sure to read the safety precautions prior to servicing the unit.

1.1 SAFETY PRECAUTIONS

1. When servicing the unit, set the ROTARY SWITCH or POWER SWITCH to OFF and unplug the power cord.
2. Observe the original lead dress.
If a short circuit is found, replace all parts which have been overheated or damaged by the short circuit.
3. After servicing the unit, make an insulation resistance test to protect the customer from being exposed to shock hazards.

1.2 INSULATION RESISTANCE TEST

1. Unplug the power cord and connect a jumper between 2 pins (black and white).
2. The grounding conductor (green or green & yellow) is to be open.
3. Measure the resistance value with an ohm meter between the jumpered lead and each exposed metallic part on the equipment at all the positions (except OFF or O) of the ROTARY SWITCH.
4. The value should be over 1MΩ.

1.3 SPECIFICATIONS

1.3.1 FOR R1402/R1802/R2102/R2402

ITEMS	MODELS				REMARK
	R1402	R1802	R2102	R2402	
POWER SUPPLY	1Ø, 115V, 60Hz	1Ø, 208/230V, 60Hz			
COOLING CAPACITY (Btu/h)	14,000	17,500/ 18,000	20,500/21,000	23,500/24,000	
INPUT (W)	1,380	1,800/ 1,850	2,410/2,470	2,760/2,820	
RUNNING CURRENT (A)	12.0	9.0/ 8.3	11.8/10.8	13.7/12.7	
REFRIGERANT (R-22) CHARGE(g)	680(24.0 OZ)	800(28.2 OZ)	730(25.8 OZ)	890(31.4 OZ)	
OPERATING TEMPERATURE	INDOOR (°C)	26.7(DB) 19.4(WB)			
	OUTDOOR (°C)	35(DB) 23.9(WB)			
EVAPORATOR	3 ROW 15 STACKS			4 ROW 18 STACKS	
CONDENSER	2 ROW 19 STACKS, L-BENDED TYPE			2 ROW 19 STACKS, U-TYPE	
FAN, INDOOR	BLOWER				
FAN, OUTDOOR	PROPELLER TYPE FAN WITH SLINGER-RING				
FAN SPEEDS, FAN/COOLING	2/3				
FAN MOTOR	6 POLES				
OPERATION CONTROL	ROTARY SWITCH				
ROOM TEMP. CONTROL	THERMOSTAT				
AIR DIRECTION CONTROL	VERTICAL LOUVER(RIGHT & LEFT)				
	HORIZONTAL LOUVER(UP & DOWN)				
CONSTRUCTION	SLIDE IN-OUT CHASSIS				
PROTECTOR	COMPRESSOR	EXTERNAL OVERLOAD PROTECTOR	INTERNAL OVERLOAD PROTECTOR		
	FAN MOTOR	INTERNAL THERMAL PROTECTOR			
POWER CORD	1.3m(3WIRE WITH GROUNDING)	1.6m (3 WIRE WITH GROUNDING)		1.3m (3 WIRE WITH GROUNDING)	
	ATTACHMENT PLUG(CORD-CONNECTED TYPE)				
DRAIN SYSTEM	DRAIN PIPE OR SPLASHED BY FAN SLINGER				
NET WEIGHT (lbs/kg)	117/53	120/54	143/65	146/66	
OUTSIDE DIMENSION (W x H x D)	(inch)	26 x 16 ^{27/32} x 26 ^{9/16}		26 x 16 ^{27/32} x 30 ^{5/16}	
	(mm)	660 x 428 x 675		660 x 428 x 770	

NOTE: Please refer to Label Quality on the product since this specification may be changed for improving performance

1.3.2 FOR R1803/R1804/R2103/R2403/LWC243NSAB0

ITEMS	MODELS		R1803	R1804 LWM1836BAG/BAS/BCG Y5USC18-6A	R2103	R2403/Y5USC24-6A LWN2432BCG/BAG LWC243NSAB0	REMARK
POWER SUPPLY			1Ø, 208/230V, 60Hz				
COOLING CAPACITY	(Btu/h)		17,500/ 18,000		20,500/21,000	23,500/24,000	
INPUT	(W)		1,800/ 1,850		2,410/2,470	2,760/2,820	
RUNNING CURRENT	(A)		9.0/ 8.3		11.8/10.8	13.7/12.7/12.9	
REFRIGERANT (R-22) CHARGE(g)			750(26.5 OZ)	710(25.0 OZ)		980(34.6 OZ)	
OPERATING TEMPERATURE	INDOOR (°C)		26.7(DB) 19.4(WB)				
	OUTDOOR (°C)		35(DB) 23.9(WB)				
EVAPORATOR			3 ROW 18 STACKS		3 ROW 15 STACKS		
CONDENSER			2 ROW 19 STACKS, L-BENDED TYPE			2 ROW 19 STACKS, U-TYPE	
FAN, INDOOR			BLOWER				
FAN, OUTDOOR			PROPELLER TYPE FAN WITH SLINGER-RING				
FAN SPEEDS, FAN/COOLING			2/3				
FAN MOTOR			6 POLES				
OPERATION CONTROL			ROTARY SWITCH				
ROOM TEMP. CONTROL			THERMOSTAT				
AIR DIRECTION CONTROL			VERTICAL LOUVER(RIGHT & LEFT)				
			HORIZONTAL LOUVER(UP & DOWN)				
CONSTRUCTION			SLIDE IN-OUT CHASSIS				
PROTECTOR	COMPRESSOR		INTERNAL OVERLOAD PROTECTOR				
	FAN MOTOR		INTERNAL THERMAL PROTECTOR				
POWER CORD			1.6m (3 WIRE WITH GROUNDING)			1.3m (3 WIRE WITH GROUNDING)	
			ATTACHMENT PLUG(CORD-CONNECTED TYPE)				
DRAIN SYSTEM			DRAIN PIPE OR SPLASHED BY FAN SLINGER				
NET WEIGHT	(lbs/kg)		120/54		143/65	146/66	
OUTSIDE DIMENSION (W x H x D)	(inch)		26 x 16 ^{27/32} x 26 ^{9/16}			26 x 16 ^{27/32} x 30 ^{5/16}	
	(mm)		660 x 428 x 675			660 x 428 x 770	

NOTE: Please refer to Label Quality on the product since this specification may be changed for improving performance

1.3.3 FOR R1801H

ITEMS		MODELS	R1801H	R1803H	REMARK
POWER SUPPLY			1Ø, 208/ 230V, 60Hz		
COOLING	CAPACITY (Btu/h)		17,500/ 18,000		
	INPUT (W)		1,940/ 2,000	1,800/1,850	
	RUNNING CURRENT (A)		9.6/ 9.0	9.0/8.3	
	E.E.R. (Btu/W.h)		9.0	9.7	
HEATING	CAPACITY (Btu/h)		9,800/ 12,000		
	INPUT (W)		3,100/ 3,670		
	RUNNING CURRENT (A)		15.0/ 16.0		
OPERATING TEMPERATURE	COOLING	INDOOR (°C)	26.7 (DB)	19.4 (WB)	
		OUTDOOR (°C)	35 (DB)	23.9 (WB)	
	HEATING	INDOOR (°C)	21.1 (DB)	15.6 (WB)	
		OUTDOOR (°C)	8.3 (DB)	6.1 (WB)	
REFRIGERANT (R-22) CHARGE(g)			740 (26.1 OZ)	750(26.5 OZ)	
EVAPORATOR			3 ROW 15 STACKS	3 ROW 18 STACKS	LOUVERED-FIN TYPE
CONDENSER			2 ROW 19 STACKS, L-BENDED TYPE		
FAN, INDOOR			BLOWER		
FAN, OUTDOOR			PROPELLER TYPE FAN WITH SLINGER-RING		
FAN SPEEDS (FAN/COOLING/HEATING)			1/ 2/ 2		
FAN MOTOR			6 POLES		
OPERATION CONTROL			ROTARY SWITCH		
ROOM TEMP. CONTROL			THERMOSTAT		
AIR DIRECTION CONTROL			VERTICAL LOUVER (RIGHT & LEFT)		
			HORIZONTAL LOUVER (UP & DOWN)		
CONSTRUCTION			SLIDE IN-OUT CHASSIS		
ELECTRIC HEATER			3.5 KW, 230V		
PROTECTOR	COMPRESSOR		INTERNAL OVERLOAD PROTECTOR		
	FAN MOTOR		INTERANL THERMAL PROTECTOR		
	ELECTRIC HEATER		FUSE LINK, BIMETAL THERMOSTAT		
POWER CORD			1.6m (3 WIRE WITH GROUDING)		
			ATTACHMENT PLUG (CORD-CONNECTED TYPE)		
DRAIN SYSTEM			DRAIN PIPE OR SPLASHED BY FAN SLINGER		
NET WEIGHT (lbs/kg)			123/ 56		
OUTSIDE DIMENSION (W x H x D)		(inch)	26 x 16 ^{27/32} x 26 ^{9/16}		
		(mm)	660 x 428 x 675		

NOTE: Please refer to Label Quality on the product since this specification may be changed for improving performance

1.3.4 FOR M1802/M1803R/M1804R

ITEMS		MODELS	M1802	M1803R	REMARK
POWER SUPPLY			1Ø, 208/230V, 60Hz		
COOLING CAPACITY (Btu/h)			17,500/ 18,000		
INPUT (W)			1,800/ 1,850		
RUNNING CURRENT (A)			9.0/ 8.3		
REFRIGERANT (R-22) CHARGE(g)			800(28.2 OZ)	750(26.5 OZ)	
OPERATING TEMPERATURE	INDOOR (°C)		26.7(DB) 19.4(WB)		
	OUTDOOR (°C)		35(DB) 23.9(WB)		
EVAPORATOR			3 ROW 15 STACKS	3 ROW 18 STACKS	LOUVERED-FIN TYPE
CONDENSER			2 ROW 19 STACKS, L-BENDED TYPE		
FAN, INDOOR			BLOWER		
FAN, OUTDOOR			PROPELLER TYPE FAN WITH SLINGER-RING		
FAN SPEEDS, FAN/COOLING			3/3		
FAN MOTOR			6 POLES		
OPERATION CONTROL			TOUCH PANEL		
ROOM TEMP. CONTROL			THERMISTOR		
AIR DIRECTION CONTROL			VERTICAL LOUVER(RIGHT & LEFT)		
			HORIZONTAL LOUVER(UP & DOWN)		
CONSTRUCTION			SLIDE IN-OUT CHASSIS		
PROTECTOR	COMPRESSOR		INTERNAL OVERLOAD PROTECTOR		
	FAN MOTOR		INTERNAL THERMAL PROTECTOR		
POWER CORD			1.6m (3 WIRE WITH GROUNDING)		
			ATTACHMENT PLUG(CORD-CONNECTED TYPE)		
DRAIN SYSTEM			DRAIN PIPE OR SPLASHED BY FAN SLINGER		
NET WEIGHT (lbs/kg)			120/54		
OUTSIDE DIMENSION (W x H x D)		(inch)	26 x 16 ^{27/32} x 26 ^{9/16}		
		(mm)	660 x 428 x 675		

NOTE: Please refer to Label Quality on the product since this specification may be changed for improving performance

1.4 FEATURES

- Designed for cooling only.
- Powerful and quiet cooling.
- Slide-in and slide-out chassis for the simple installation and service.
- Reversible inlet grille.

- Side air-intake, side cooled-air discharge.
- Built in adjustable THERMOSTAT.
- Washable one-touch filter.
- Compact size.

1.5 CONTROL LOCATIONS

1.5.1 COOLING ONLY MODEL

• VENTILATION

The ventilation lever must be in the CLOSE position in order to maintain the best cooling conditions.

When a fresh air is necessary in the room, set the ventilation lever to the OPEN position.

The damper is opened and room air is exhausted.

NOTE: Before using the ventilation feature, make the lever, as shown. First, pull down part (A) to horizontal line with part (B).

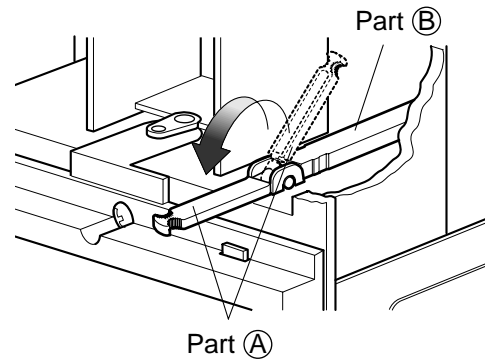

• THERMOSTAT

Thermostat will automatically control the temperature of the room. Select the higher number for the lower temperature of the room. The temperature is selected by positioning the knob to the desired position.

The 5 or 6 position is a normal setting for average conditions.

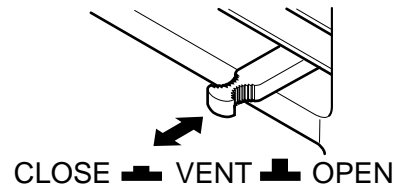

• OPERATION

- OFF : Turns the air conditioner off.
- MED FAN : Permits the medium fan speed operation without cooling.
- LOW FAN : Permits the low fan speed operation without cooling.
- HIGH COOL: Permits cooling with the high fan speed operation.
- MED COOL : Permits cooling with the medium fan speed operation.
- LOW COOL: Permits cooling with the low fan speed operation.

• AUTO SWING

- ON : Air swing is operated while OPERATION knob is set to the COOL position.
- OFF : Stops the operation of air swing.

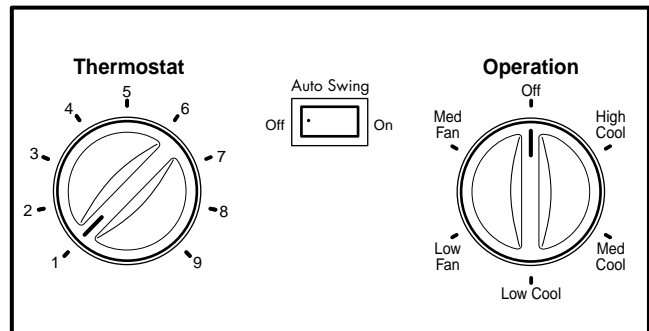

1.5.2 COOLING AND HEATING MODEL

• CAUTION

When the air conditioner has been performing its cooling operation and is turned off or set to the fan position, wait at least 3 minutes before resetting to the cooling operation again.

• THERMOSTAT

Turn the thermostat control to the desired setting. The control position is a normal setting for average conditions. You can change this setting, if necessary, in accordance with your temperature preference.

The thermostat automatically controls cooling or heating, but the fan runs continuously whenever the air conditioner is in operation. If the room is too warm, turn the thermostat control clockwise. If the room is too cool, turn the thermostat control anticlockwise.

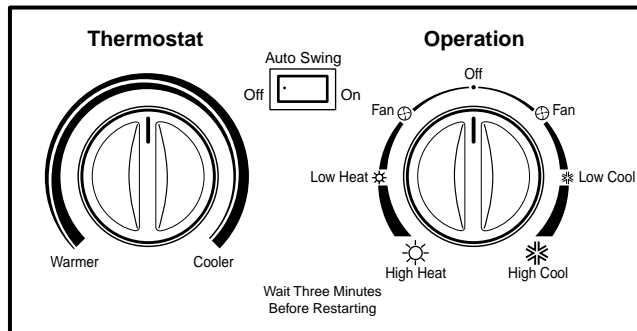

• OPERATION

OFF (○) : Turns the air conditioner off.

FAN (⊕) : Permits the low fan speed operation without cooling (heating).

LOW COOL (*) : Permits cooling with the low fan speed operation.

HIGH COOL (⊛) : Permits cooling with the high fan speed operation.

LOW HEAT (*) : Permits heating with the low fan speed operation.

HIGH HEAT (⊛) : Permits heating with the high fan speed operation.

• AUTO SWING

ON : Starts the operation of air swing.

OFF : Stops the operation of air swing.

- Before you turn the unit off, please press the Auto Swing switch to off.

A slight heat odor may come from the unit when first switching to HEAT after the cooling season is over. This odor, caused by fine dust particles on the heater, will disappear quickly.

1.5.3 COOLING ONLY MODEL WITH TOUCH TYPE

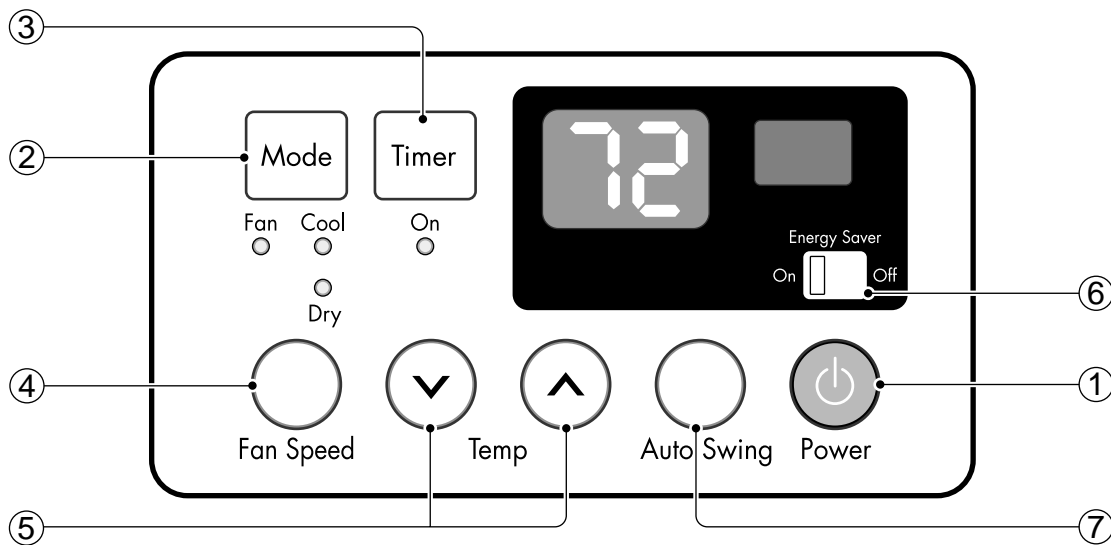

Precaution: The Remote Control unit will not function properly if strong light strikes the sensor window of the air conditioner or if there are obstacles between the Remote Control unit and the air conditioner.

1 POWER BUTTON

Operation starts, when this button is pressed and stops when you press the button again.

2 OPERATION MODE SELECTION BUTTON

Select Cooling, or Fan or Dehumidification(Dry) mode with button. (Dry mode is not to all models.)

3 ON/OFF TIMER BUTTON

Set the time of starting and stopping operation. The timer is set by 1 hour.

4 FAN SPEED SELECTOR

Select the fan speed in three steps.

- High [F3] → Low[F1] → Med[F2]→ High[F3]... .

5 ROOM TEMPERATURE SETTING BUTTON

Control the room temperature within a range of 60°F to 86°F by 1°F.

6 ENERGY SAVER

The fan stops when the compressor stops cooling.

Approximately every 3 minutes the fan will turn on and check the room air to determine if cooling is needed.

7 AUTO SWING BUTTON

Control the horizontal air direction by air swing system.

2. DISASSEMBLY INSTRUCTIONS

— Before the following disassembly, POWER SWITCH is set to OFF and disconnected the power cord.

2.1 MECHANICAL PARTS

2.1.1 FRONT GRILLE

1. Open the inlet grille upward or downward.
2. Remove the screw which fastens the front grille.
3. Pull the front grille from the right side.
4. Remove the front grille. (See Fig. 1)
5. Re-install the component by referring to the removal procedure.

NOTE: Mark Δ of inlet grille means opening direction.

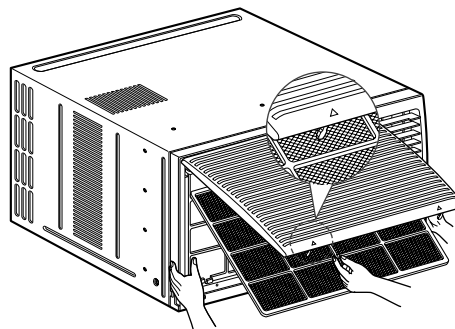

Figure 1

2.1.2 CABINET

1. After disassembling the FRONT GRILLE, remove the screws which fasten the cabinet at both sides. Keep these for later use.
2. Remove the two screws which fasten the cabinet at back. (See Fig. 2)
3. Pull the base pan forward.

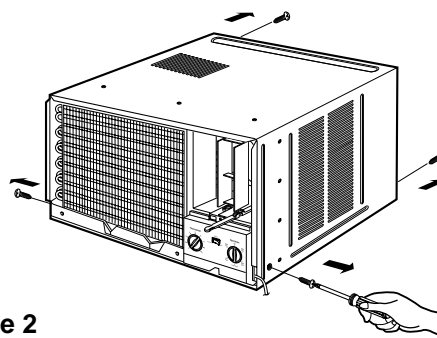

Figure 2

2.1.3 CONTROL BOX

1. Remove the front grille. (Refer to section 2.1.1)
2. Pull the base pan forward so that you can remove the 2 screws which fasten the cover control at the right side. (See Fig. 3)
3. Remove the 3 screws which fasten the control box. (See Fig. 3)
4. Discharge the capacitor by placing a 20,000 ohm resistor across the capacitor terminals.
5. Disconnect two wire housings in the control box.
6. Pull the control box forward completely.
7. Re-install the components by referring to the removal procedure. (See Fig. 3)
(Refer to the circuit diagram found on page 28~31 in this manual and on the control box.)

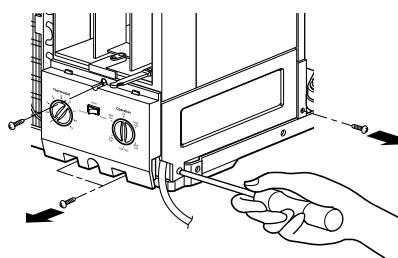

Figure 3

2.2 AIR HANDLING PARTS

2.2.1 COVER (AT THE TOP)

1. Remove the front grille. (Refer to section 2.1.1)
2. Remove the cabinet. (Refer to section 2.1.2)
3. Remove 11 screws which fasten the brace and covers.
4. Remove the covers and the brace. (See Fig. 4)
5. Re-install the components by referring to the removal procedure, above.

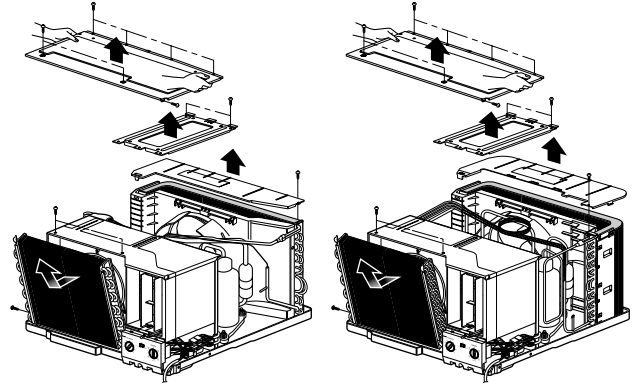

Figure 4

2.2.2 BLOWER

1. Remove the cover. (Refer to section 2.2.1)
2. Remove the 3 screws which fasten the evaporator at the left side and the top side. (See Fig. 4)
3. Move the evaporator sideward carefully.
4. Remove the 2 terminals carefully (See Fig. 5, Electric Heater Model only)
5. Remove the 3 screws which fasten the Heater Cover. (See Fig. 5, Electric Heater Model only)
6. Remove the Heater Cover. (See Fig. 5, Electric Heater Model only)
7. Remove the orifice from the air guide carefully. (See Fig. 6, Except Electric Heater Model)
8. Remove the clamp which secures the blower with plier. (See Fig. 6)
9. Remove the blower with plier or your hand without touching blades. (See Fig. 7)
10. Re-install the components by referring to the removal procedure, above.

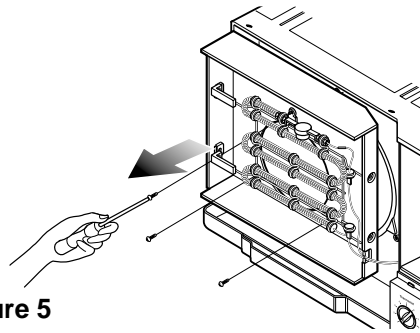

Figure 5

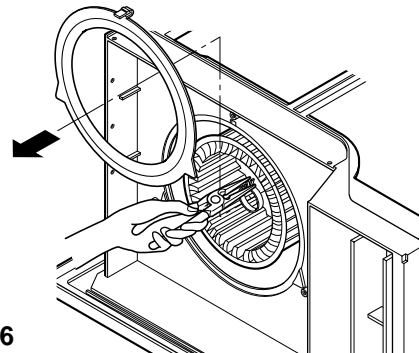

Figure 6

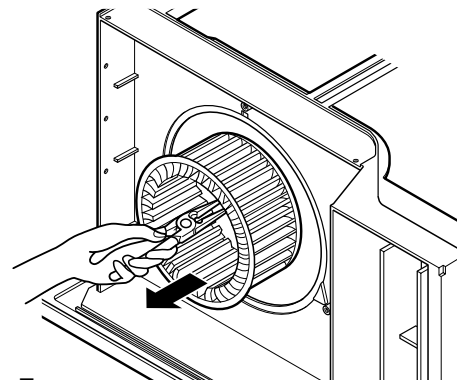

Figure 7

2.2.3 FAN

1. Remove the cabinet. (Refer to section 2.1.2)
2. Remove the brace and shroud cover.
(Refer to section 2.2.1)
3. Remove the side cover with 2 screws.
(See Fig. 8(b))
4. Remove the 5 or 6 screws which fasten the condenser.
5. Move the condenser sideways carefully.
6. Remove the clamp which secures the fan.
7. Remove the fan. (See Fig. 8(a), 8(b))
8. Re-install the components by referring to the removal procedure, above.

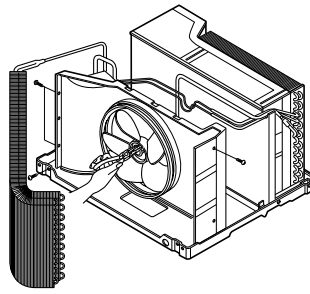

Figure 8(a)

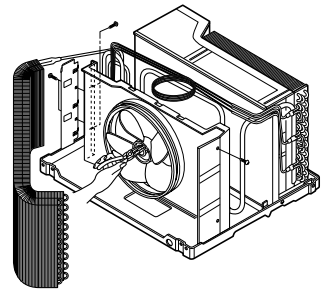

Figure 8(b)

2.2.4 SHROUD

1. Remove the fan. (Refer to section 2.2.3)
2. Remove the 2 screws which fasten the shroud.
3. Remove the shroud. (See Fig. 9(a), 9(b))
4. Re-install the component by referring to the removal procedure, above.

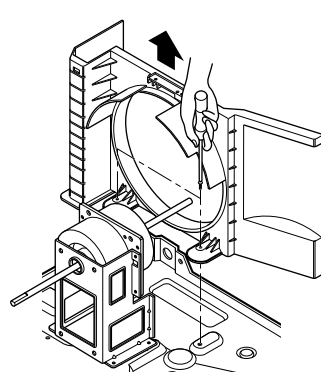

Figure 9(a)

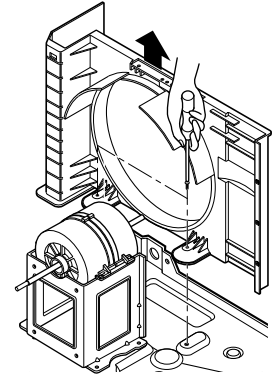

Figure 9(b)

2.3 ELECTRICAL PARTS

2.3.1 MOTOR

1. Remove the cabinet. (Refer to section 2.1.2)
2. Remove the cover control and disconnect a wire housing in control box. (Refer to section 2.1.3)
3. Remove the blower. (Refer to section 2.2.2)
4. Remove the fan. (Refer to section 2.2.3)
5. Remove the 4 screws which fasten the motor.
(See Fig. 10(a), 10(b))
6. Remove the motor.
7. Re-install the components by referring to the removal procedure, above.

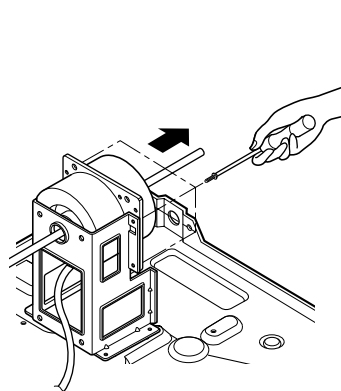

Figure 10(a)

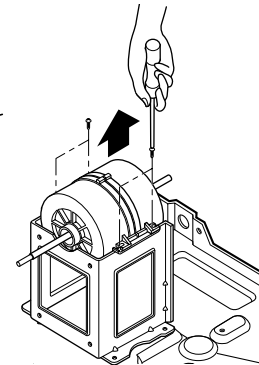

Figure 10(b)

2.3.2 COMPRESSOR

1. Remove the cabinet. (Refer to section 2.1.2)
2. Discharge the refrigerant system using Freon™ Recovery System.
If there is no valve to attach the recovery system, install one (such as a WATCO A-1) before venting the Freon™. Leave the valve in place after servicing the system.
3. Disconnect the 3 leads from the compressor.
4. After purging the unit completely, unbraid the suction and discharge tubes at the compressor connections.
5. Remove the 3 nuts and the 3 washers which fasten the compressor. (See Fig. 11)
6. Remove the compressor.
7. Re-instill the components by referring to the removal procedure, above.

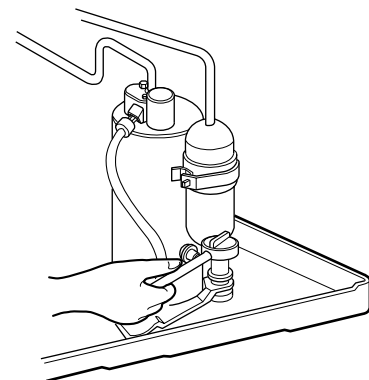

Figure 11

2.3.3 CAPACITOR

1. Remove the control box. (Refer to section 2.1.3)
2. Remove the screw and knobs which fasten the display panel.
3. Disconnect the 2 leads from the rocker switch and remove the panel.
4. Remove a screw and unfold the control box. (See Fig. 12)
5. Remove the screw and the clamp which fastens the capacitor. (See Fig. 12)
6. Disconnect all the leads of capacitor terminals.
7. Re-install the components by referring to the removal procedure, above.

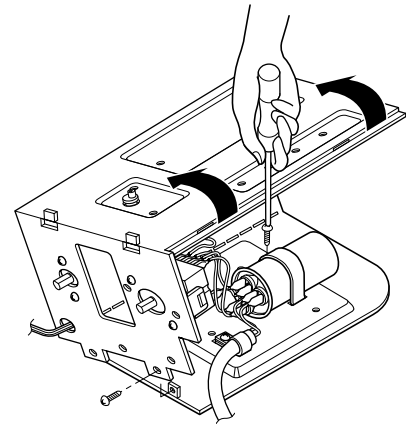

Figure 12

2.3.4 POWER CORD

1. Remove the control box. (Refer to section 2.1.3)
2. Unfold the control box. (Refer to section 2.3.3)
3. Disconnect the grounding screw from the control box.
4. Disconnect 2 receptacles.
5. Remove a screw which fastens the clip cord.
6. Pull the power cord. (See Fig. 13)
7. Re-install the component by referring to the removal procedure, above.
(Use only one ground-marked hole \oplus for ground connection.)
8. If the supply cord of this appliance is damaged, it must be replaced by the special cord.
(The special cord means the cord which has the same specification marked on the supply cord fitted to the unit.)

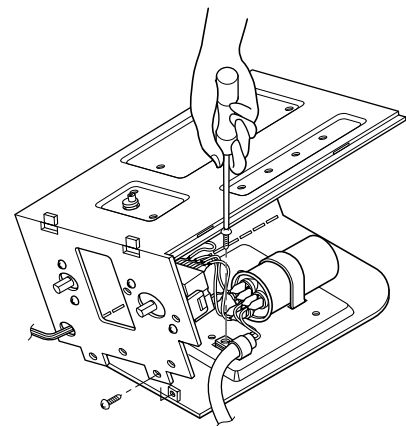

Figure 13

2.3.5 THERMOSTAT

1. Remove the control box. (Refer to section 2.1.3)
2. Unfold the control box. (Refer to section 2.3.3)
3. Remove the 2 screws which fasten the thermostat.
4. Disconnect all the leads of thermostat terminals.
5. Remove the thermostat. (See Fig. 14)
6. Re-install the components by referring to the removal procedure, above.

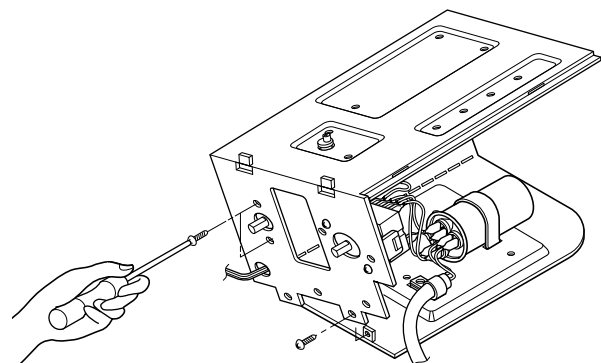

Figure 14

2.3.6 ROTARY SWITCH

1. Remove the control box. (Refer to section 2.1.3)
2. Unfold the control box. (Refer to section 2.3.3)
3. Remove 2 screws which fasten the rotary switch.
4. Disconnect all the leads of the rotary switch terminals.
5. Remove the rotary switch. (See Fig. 15)
6. Re-install the components by referring to the above removal procedure, above.

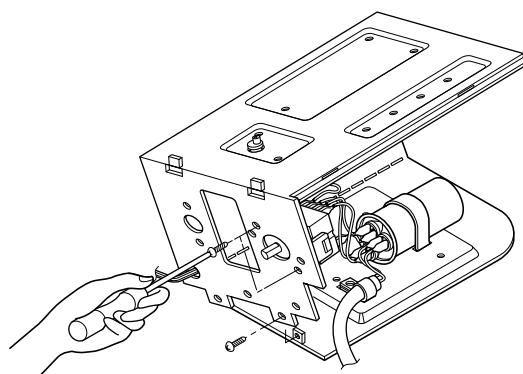

Figure 15

2.3.7 SYNCHRONOUS MOTOR

1. Remove the control box. (Refer to section 2.1.3)
2. Unfold the control box. (Refer to section 2.3.3)
3. Remove the crankshaft.
4. Disconnect all the leads of the synchronous motor.
5. Remove the 2 screws which fasten the synchronous motor. (See Fig. 16)
6. Re-install the components by referring to the removal procedure, above.

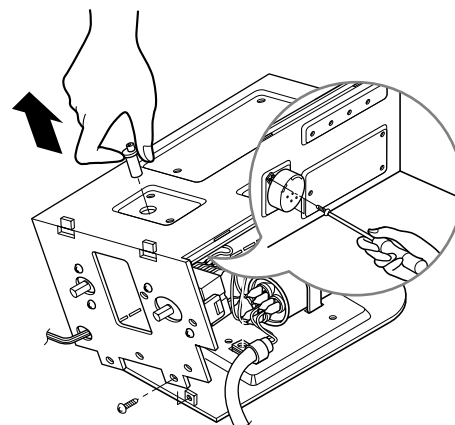

Figure 16

2.4 REFRIGERATION CYCLE

CAUTION

Discharge the refrigerant system using Freon™ Recovery System.
If there is no valve to attach the recovery system, install one (such as a WATCO A-1) before venting the Freon™. Leave the valve in place after servicing the system.

2.4.1 CONDENSER

1. Remove the cabinet. (Refer to section 2.1.2)
2. Remove the brace and the shroud cover. (Refer to section 2.2.1)
3. Remove 2 screws which fasten the side cover. (See Fig. 17(b))
4. Remove the 5 or 6 screws which fasten the condenser.
5. After discharging the refrigerant completely, unbraid the interconnecting tube at the condenser connections.
6. Remove the condenser.
7. Re-install the components by referring to notes. (See Fig. 17)

2.4.2 EVAPORATOR

1. Remove the cabinet. (Refer to section 2.1.2)
2. Remove the top cover and the brace. (Refer to section 2.2.1)
3. Discharge the refrigerant completely.
4. Remove the 3 screws which fasten the evaporator at the left side and the top side.
5. Move the evaporator sideward carefully and then unbraid the interconnecting tube at the evaporator connectors.
6. Remove the evaporator.
7. Re-install the components by referring to notes. (See Fig. 18)

2.4.3 CAPILLARY TUBE

1. Remove the cabinet. (Refer to section 2.1.2)
2. Remove the brace. (Refer to section 2.2.1)
3. After discharging the refrigerant completely, unbraid the interconnecting tube at the capillary tube.
4. Remove the capillary tube.
5. Re-install the components by referring to notes.

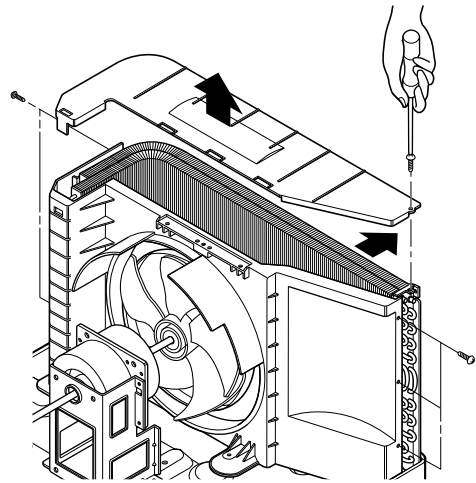

Figure 17(a)

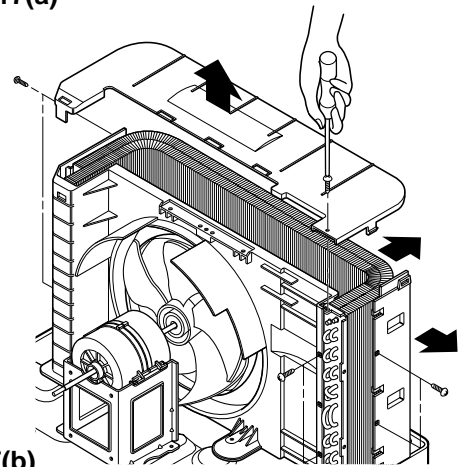

Figure 17(b)

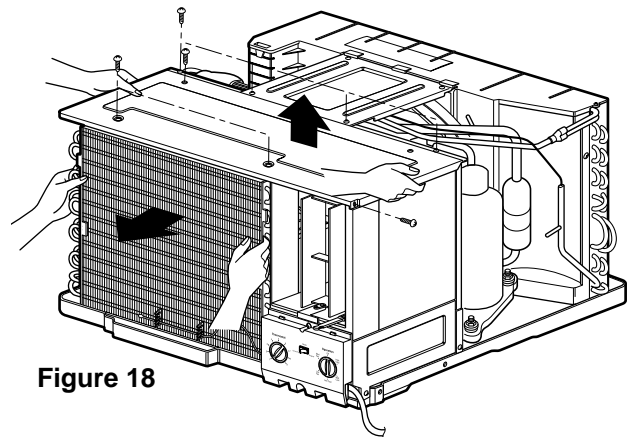

Figure 18

NOTES

— Replacement of the refrigeration cycle.

1. When replacing the refrigeration cycle, be sure to discharge the refrigerant system using a Freon™ recovery System.
If there is no valve to attach the recovery system, install one (such as a WATCO A-1) before venting the Freon™. Leave the valve in place after servicing the system.
2. After discharging the unit completely, remove the desired component, and unbrace the pinch-off tubes.
3. Solder service valves into the pinch-off tube ports, leaving the valves open.
4. Solder the pinch-off tubes with Service valves.
5. Evacuate as follows.
 - 1) Connect the vacuum pump, as illustrated Fig. 19A.
 - 2) Start the vacuum pump, slowly open manifold valves A and B with two full turns counterclockwise and leave the valves closed. The vacuum pump is now pulling through valves A and B up to valve C by means of the manifold and entire system.

CAUTION

If high vacuum equipment is used, just crack valves A and B for a few minutes, then open slowly with the two full turns counterclockwise. This will keep oil from foaming and being drawn into the vacuum pump.

- 3) Operate the vacuum pump for 20 to 30 minutes, until 600 microns of vacuum is obtained. Close valves A and B, and observe vacuum gauge for a few minutes. A rise in pressure would indicate a possible leak or moisture remaining in the system. With valves A and B closed, stop the vacuum pump.
- 4) Remove the hose from the vacuum pump and place it on the charging cylinder. See Fig. 19B. Open valve C.
Discharge the line at the manifold connection.
- 5) The system is now ready for final charging.

6. Recharge as follows :

- 1) Refrigeration cycle systems are charged from the High-side. If the total charge cannot be put in the High-side, the balance will be put in the suction line through the access valve which you installed as the system was opened.
- 2) Connect the charging cylinder as shown in Fig. 19B. With valve C open, discharge the hose at the manifold connection.
- 3) Open valve A and allow the proper charge to enter the system. Valve B is still closed.
- 4) If more charge is required, the high-side will not take it. Close valve A.
- 5) With the unit running, open valve B and add the balance of the charge.
 - a. Do not add the liquid refrigerant to the Low-side.
 - b. Watch the Low-side gauge; allow pressure to rise to 30 lbs.
 - c. Turn off valve B and allow pressure to drop.
 - d. Repeat steps B and C until the balance of the charge is in the system.
- 6) When satisfied the unit is operating correctly, use the pinch-off tool with the unit still running and clamp on to the pinch-off tube. Using a tube cutter, cut the pinch-off tube about 2 inches from the pinch-off tool. Use sil-fos solder and solder pinch-off tube closed. Turn off the unit, allow it to set for a while, and then test the leakage of the pinch-off connection.

Equipment needed: Vacuum pump, Charging cylinder, Manifold gauge, Brazing equipment. Pinch-off tool capable of making a vapor-proof seal, Leak detector, Tubing cutter, Hand Tools to remove components, Service valve.

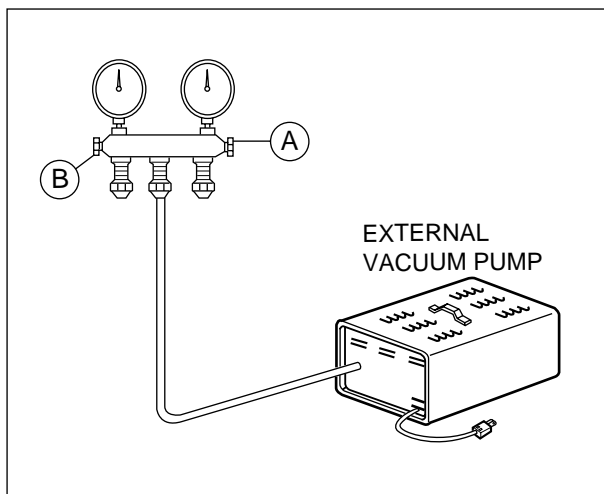
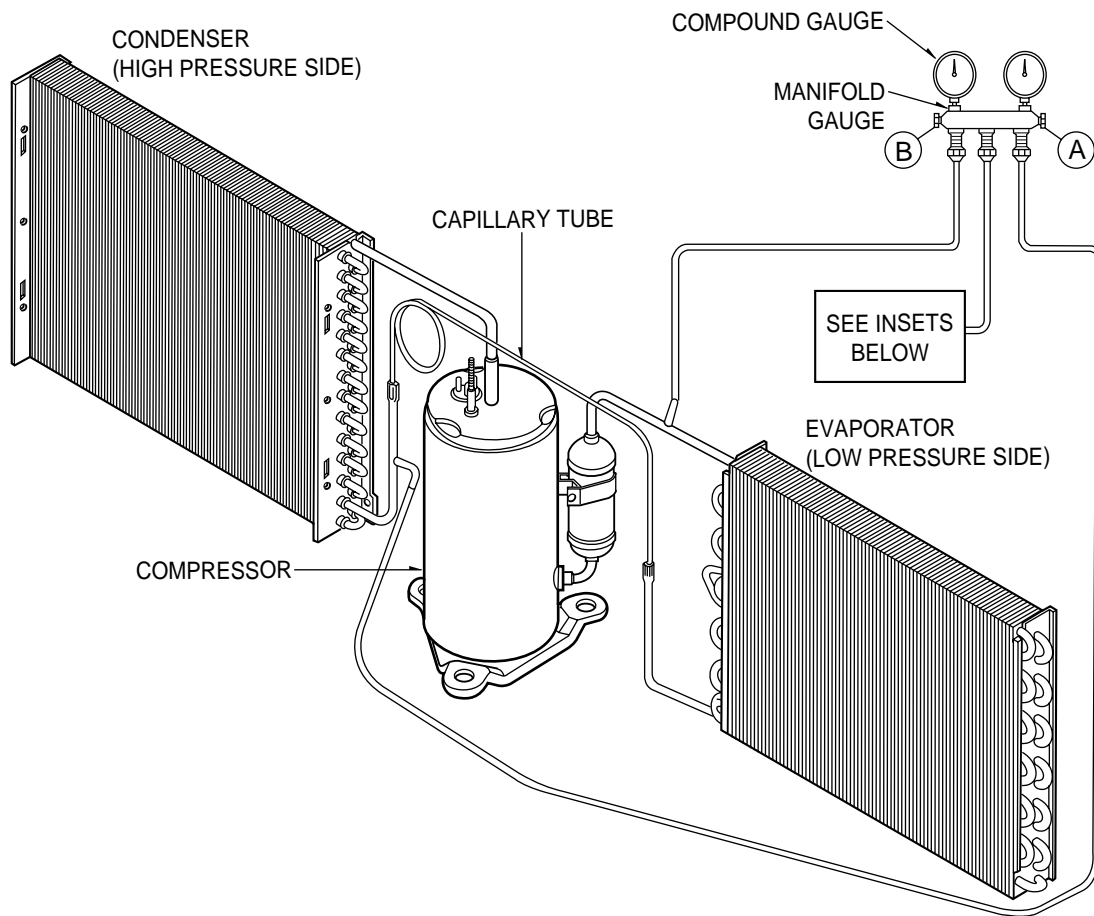

Figure 19A-Pulling Vacuum

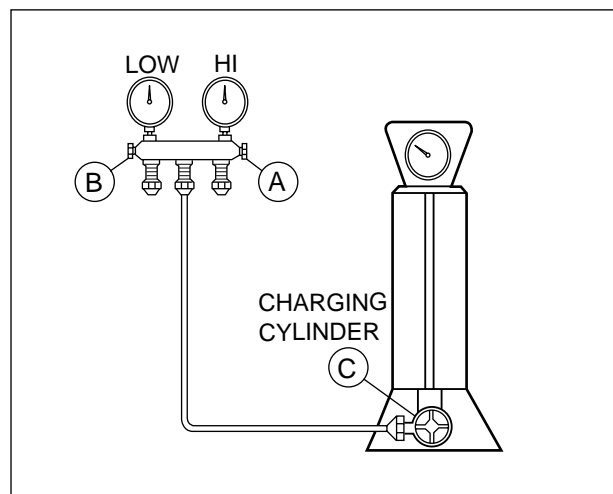
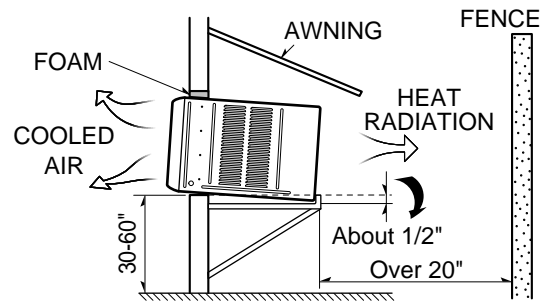
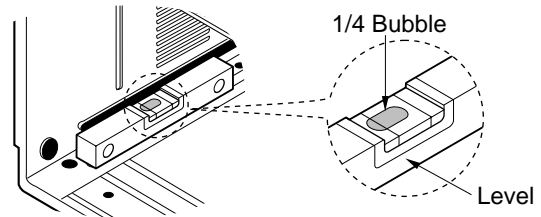

Figure 19B-Charging

3. INSTALLATION

3.1 HOW TO INSTALL THE UNIT

1. To avoid vibration and noise, make sure the unit is installed securely and firmly.
2. Install the unit where the sunlight does not shine directly on the unit.
If the unit receives direct sunlight, build an awning to shade the cabinet.
3. There should be no obstacle, like a fence, within 20" which might restrict heat radiation from the condenser.
4. To prevent reducing performance, install the unit so that louvers of the cabinet are not blocked.
5. Install the unit a little obliquely outward not to leak the condensed water into the room (about 1/2" or 1/4 bubble with level).
6. Install the unit with its bottom portion 30~60" above the floor level.
7. Stuff the foam between the top of the unit and the wall to prevent air and insects from getting into the room.
8. The power cord must be connected to an independent circuit. The green wire must be grounded.
9. Connect the drain tube to the base pan hole in the rear side if you need to drain (consult a dealer).
Plastic hose or equivalent may be connected to the drain tube.



3.2 HOW TO USE THE REVERSIBLE INLET GRILLE

The grille is designed to clean the filter both upward and downward.

A. BEFORE ATTACHING THE FRONT GRILLE TO THE CABINET, IF YOU WANT TO PULL OUT THE FILTER UPWARD;

1. Open the inlet grille slightly (a).
2. Turn inside out the front grille (a).
3. Disassemble the inlet grille from the front grille with separating the hinged part by inserting a straight type screw-driver tip (b).
4. Then, rotate the inlet grille 180 degrees and insert the hooks into bottom holes of the front grille.
5. Insert the filter and attach the front grille to the cabinet.

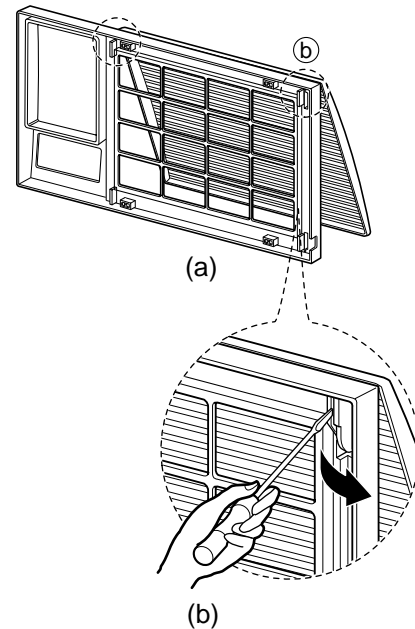

B. IF YOU WANT TO PULL OUT THE FILTER DOWNWARD;

The grille is already designed for that way.

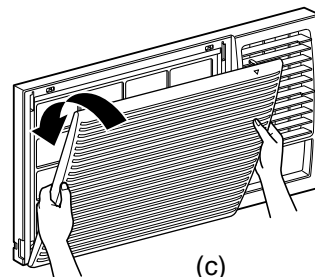

3.3 WINDOW REQUIREMENTS

NOTE: All supporting parts should be secured to firm wood, masonry, or metal.

The models of the specific area don't contain installation kit.

3.3.1 WINDOW REQUIREMENTS

1. This unit is designed for installation in standard double hung windows with actual opening widths from 29" to 41". The top and bottom window sashes must open sufficiently to allow a clear vertical opening of 18" from the bottom of the upper sash to the window stool.
2. The stool offset (height between the stool and sill) must be less than 1 1/4".

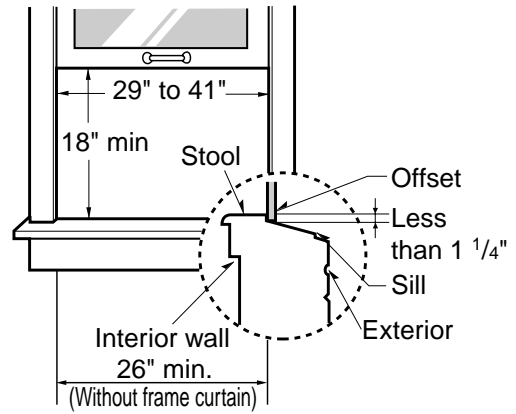

3.4 INSTALLATION KITS CONTENTS

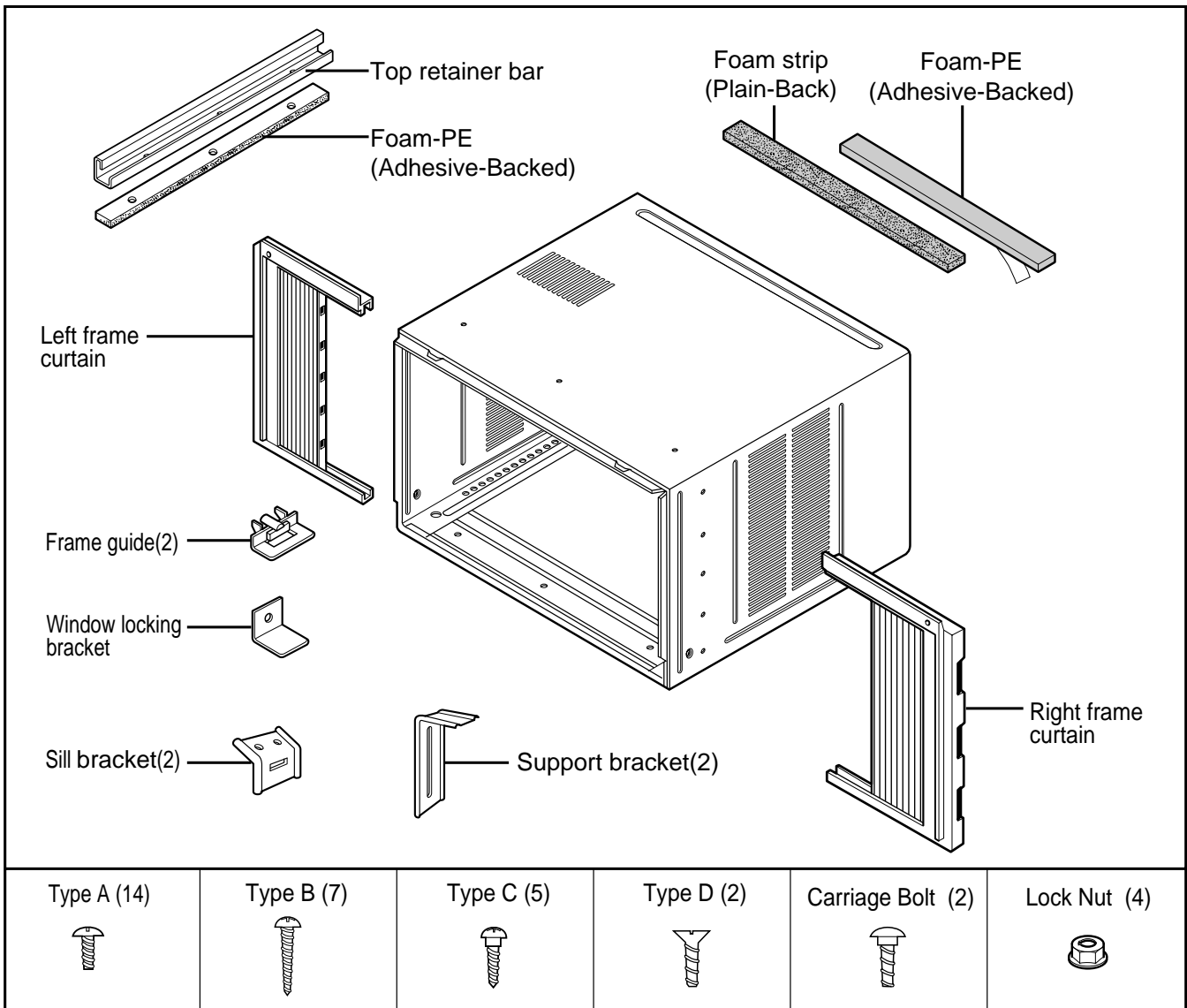

3.5 SUGGESTED TOOL REQUIREMENTS

SCREWDRIVER(+, -), RULER, KNIFE, HAMMER, PENCIL, LEVEL

3.5.1 PREPARATION OF CHASSIS

1. Remove the screws which fasten the cabinet at both sides and at the back. Keep these two screws which fasten the cabinet at both sides for later use.

2. Slide the unit out from the cabinet by gripping the base pan handle and pulling forward while bracing the cabinet.

3. Cut the window sash seal to the proper length. Peel off the backing and attach the Foam-PE to the underside of the window sash.

4. Remove the backing from Foam-PE with 3 holes and attach it to the bottom of the Top retainer bar.

5. Attach the Top retainer bar onto the top of the cabinet with 3 screws (Type A).

6. Insert the Frame guides into the bottom of the cabinet.

7. Insert the Frame Curtain into the Top retainer bar and Frame guides.

8. Fasten the curtains to the unit with 10 screws (Type A) at both sides.

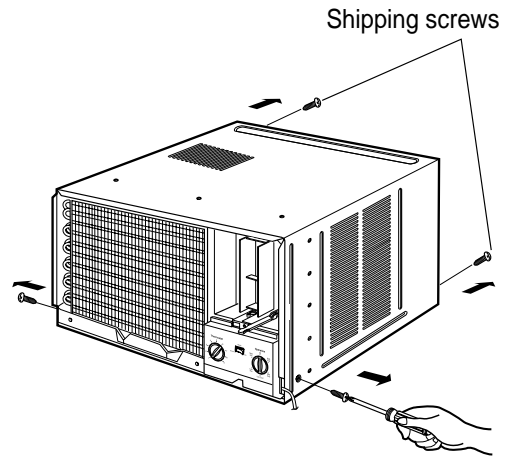

Figure 20

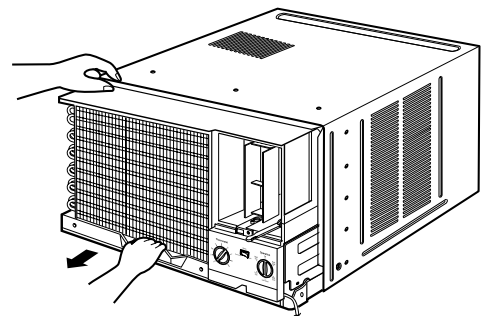

Figure 21

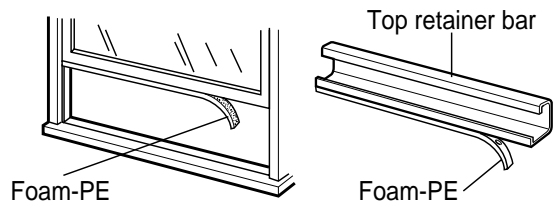

Figure 22

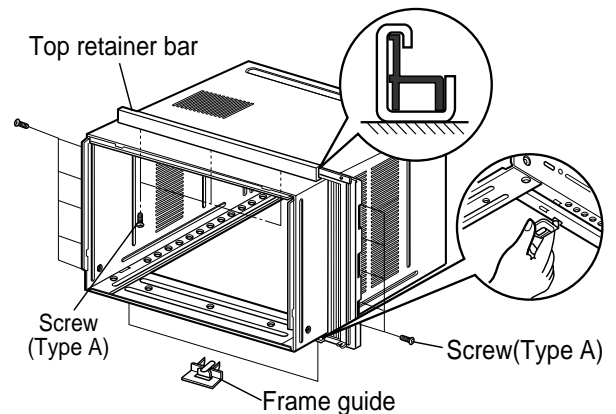
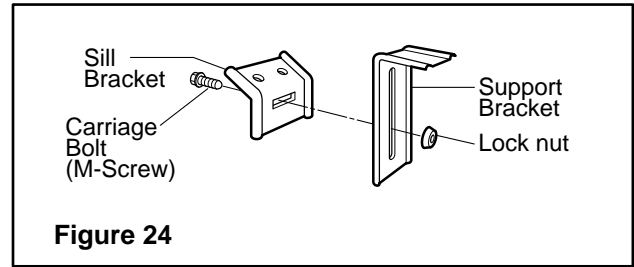

Figure 23

3.6 CABINET INSTALLATION

1. Open the window. Mark a line on the center of the window stool between the side window stop moldings. Loosely attach the sill bracket to the support bracket using the carriage bolt and the lock nut.



2. Attach the sill bracket to the window sill using the screws (Type B). Carefully place the cabinet on the window stool and align the center mark on the bottom front with the center line marked window stool.

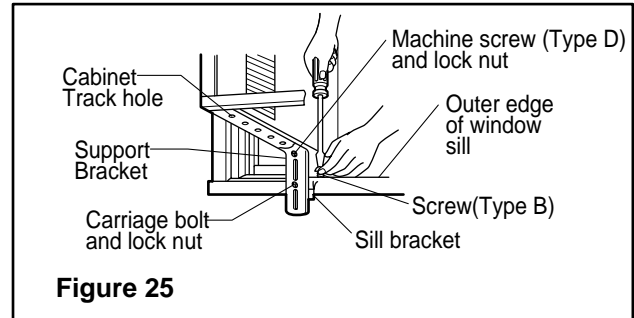

3. Using the M-screw and the lock nut, attach the support bracket to the cabinet track hole. Use the first track hole after the sill bracket on the outer edge of the window sill. Tighten the carriage bolt and the lock nut. Be sure the cabinet slants outward.

CAUTION: Do not drill a hole in the bottom pan. The unit is designed to operate with approximately 1/2" of water in bottom pan.

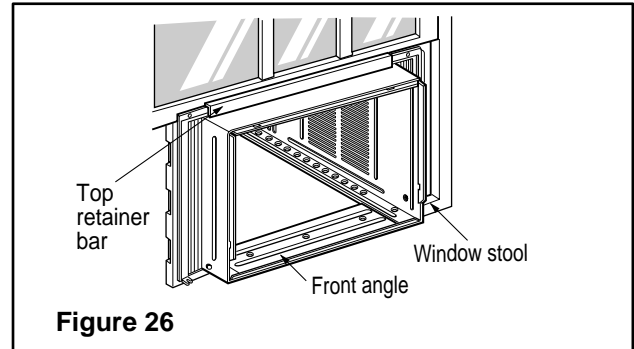

4. Pull the bottom window sash down behind the Top retainer bar until they meet.

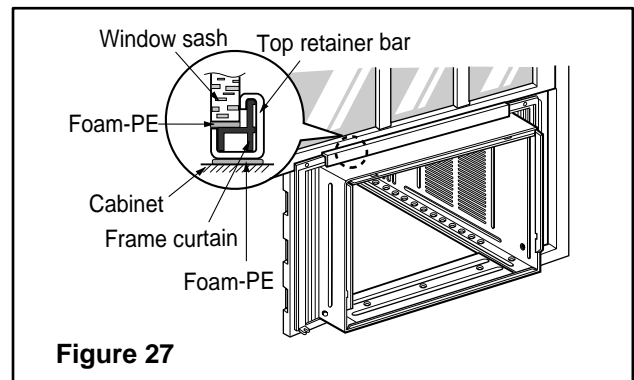

- NOTE:**
1. Do not pull the window sash down so tightly that the movement of Frame curtain is restricted. Attach the cabinet to the window stool by driving the screws (Type B) through the cabinet into window stool.
 2. The cabinet should be installed with a very slight tilt downward toward the outside.

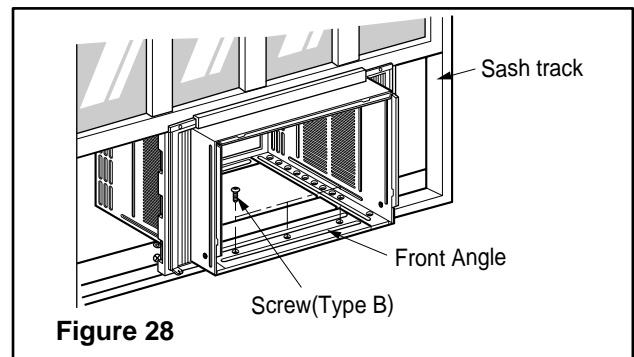

5. Pull each Frame curtain fully to each window sash track, and pull the bottom window sash down behind the Top retainer bar until it meets.

6. Attach each Frame curtain the window sash by using screws (Type C). (See Fig. 29)

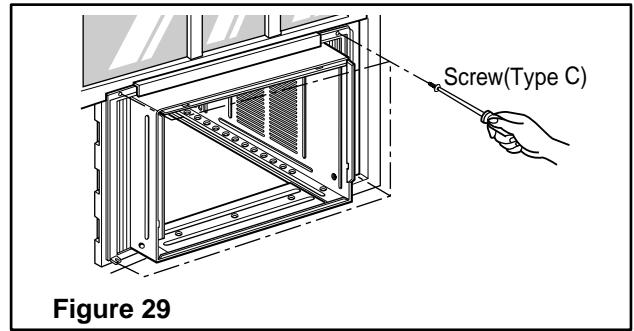

7. Slide the unit into the cabinet. (See Fig. 30)

CAUTION: For security purpose, reinstall screws (Type A) at cabinet's sides.

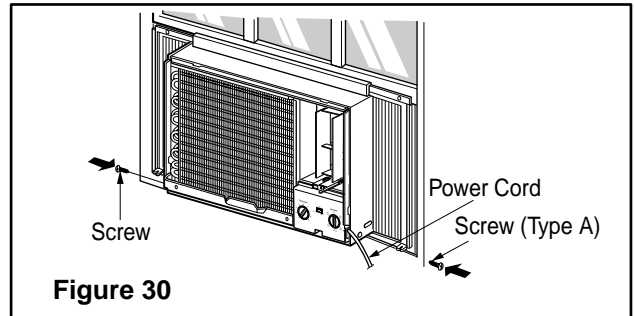

8. Cut the Foam-strip to the proper length and insert between the upper window sash and the lower window sash. (See Fig. 31)

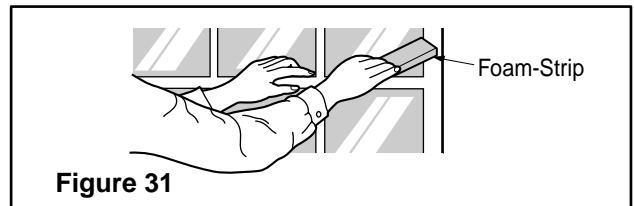

9. Attach the Window locking bracket with a screw (Type C). (See Fig. 32)

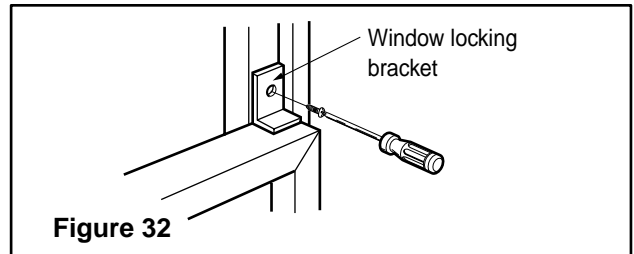

10. Attach the front grille to the cabinet by inserting the tabs on the grille into the tabs on the front of the cabinet. Push the grille in until it snaps into place. (See Fig.33)

11. Lift the inlet grille and secure it with a screw (Type A) through the front grille. (See Fig. 33)

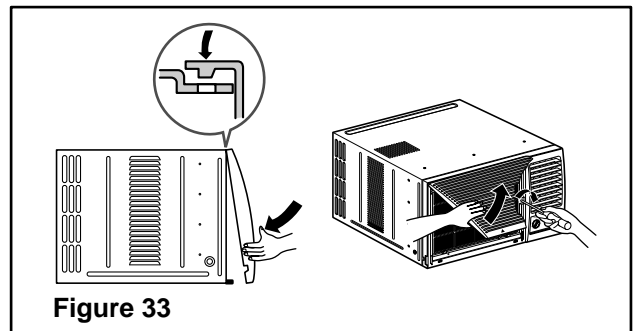

12. **Window installation of room air conditioner is now completed.**

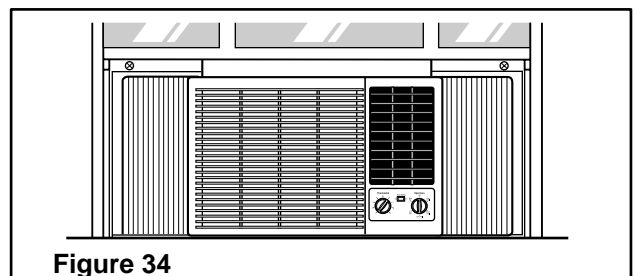

4. TROUBLESHOOTING GUIDE

4.1 OUTSIDE DIMENSIONS

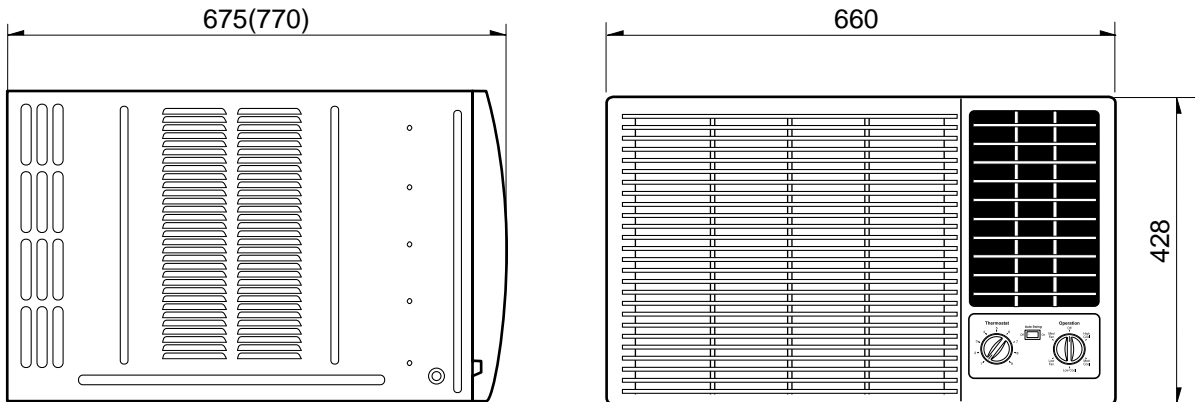

4.2 PIPING SYSTEM

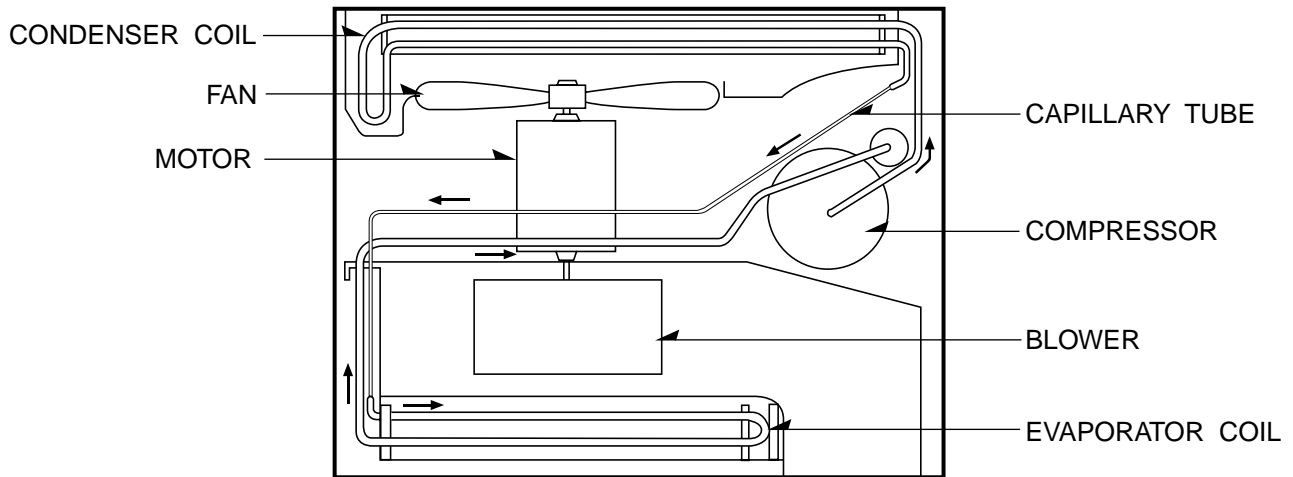

Following is a brief description of the important components and their functions in the refrigeration system. Refer to Fig. 35 to follow the refrigeration cycle and the flow of the refrigerant in the cooling cycle.

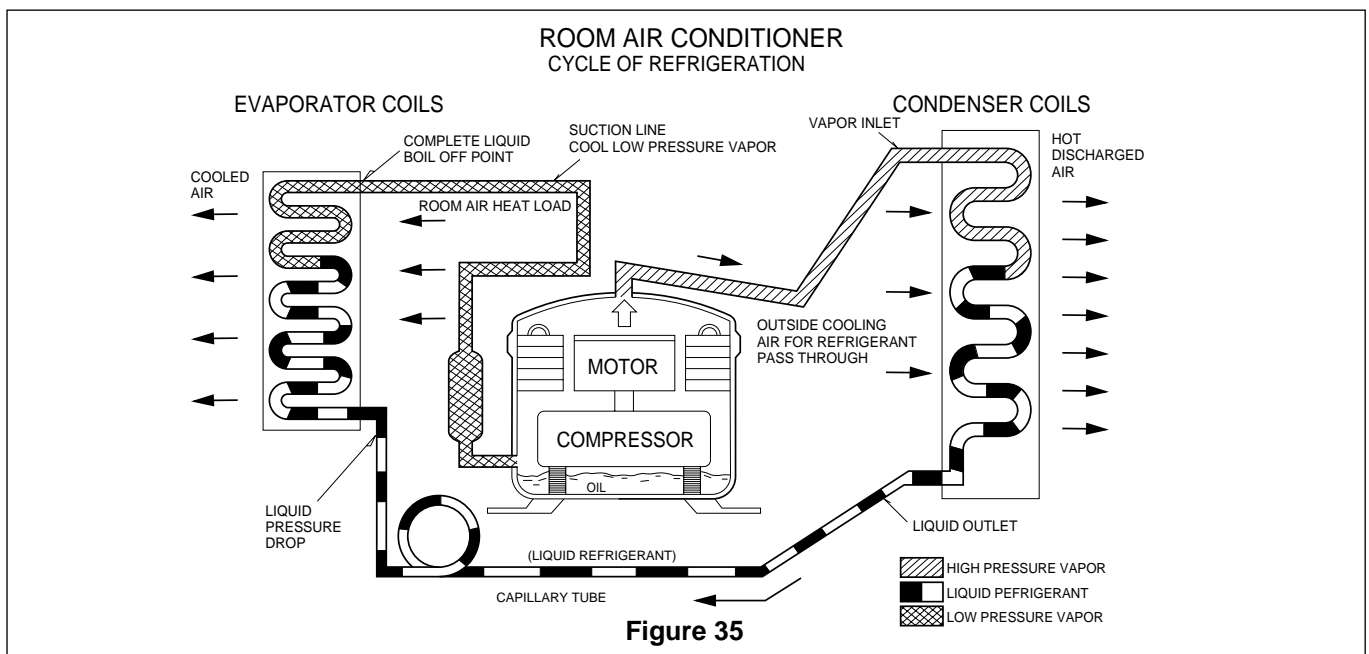

4.3 TROUBLESHOOTING GUIDE

In general, possible trouble is classified in two causes.

The one is called Starting Failure which is caused from an electrical defect, and the other is Ineffective Air Conditioning caused by a defect in the refrigeration circuit and improper application.

Unit runs but poor cooling

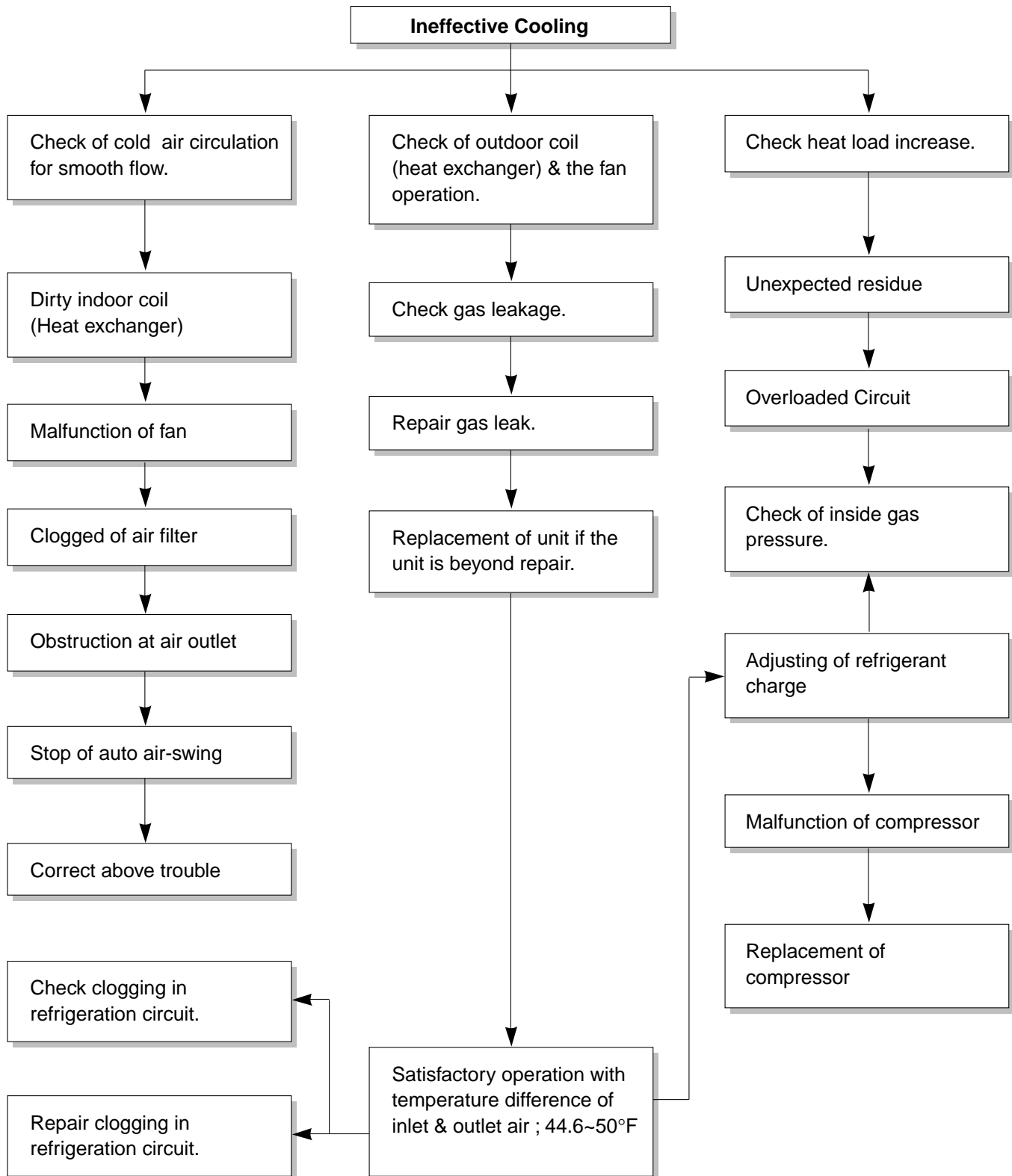

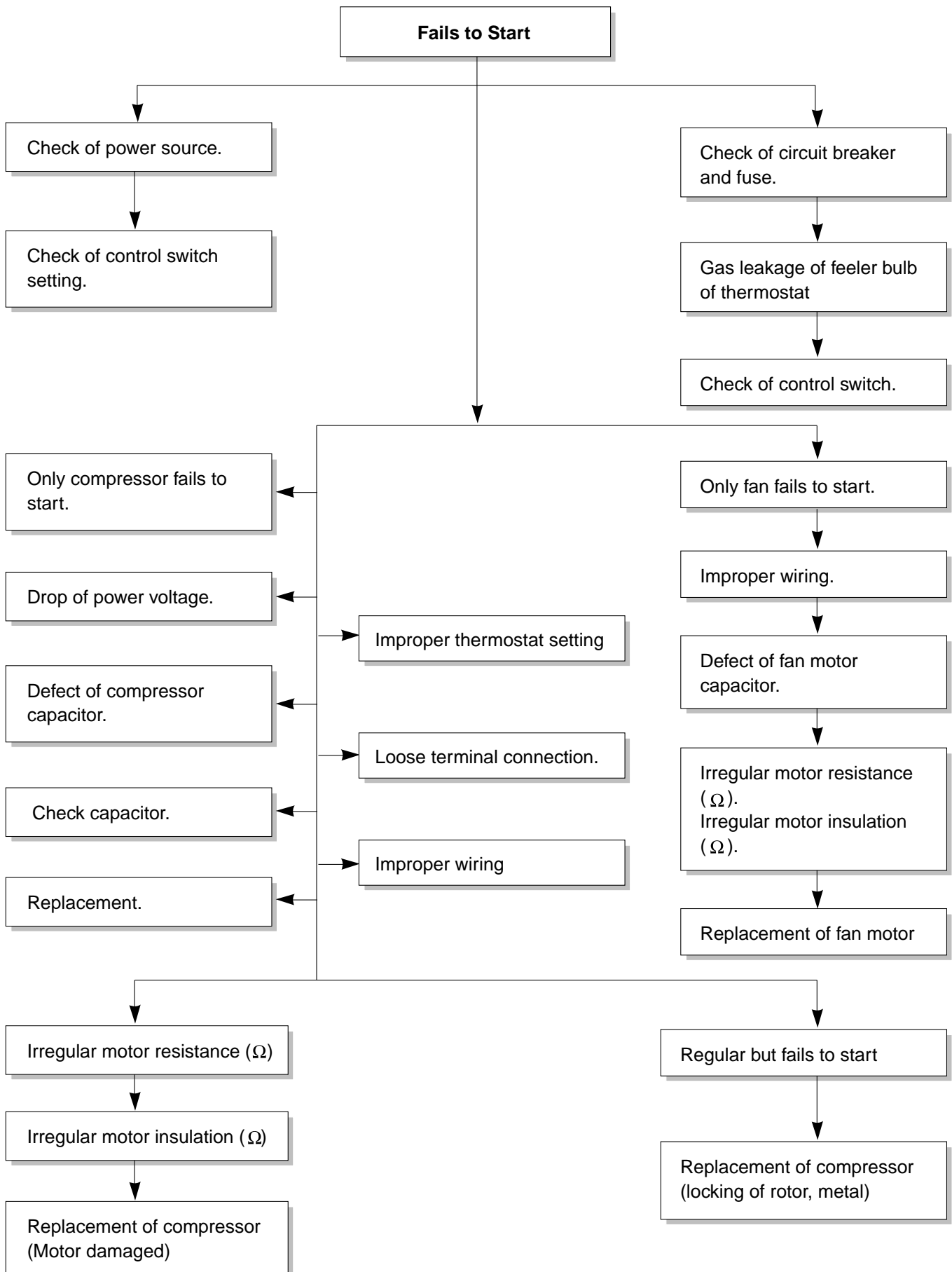

COMPLAINT	CAUSE	REMEDY
Fan motor will not run.	No power	Check voltage at outlet. Correct if none.
	Power supply cord	Check voltage to rotary switch. If none, check power supply cord. Replace cord if circuit is open.
	Rotary switch	Check switch continuity. Refer to wiring diagram for terminal identification. Replace switch if defective.
	Wire disconnected or connection loose	Connect wire. Refer to wiring diagram for terminal identification. Repair or replace loose terminal.
	Capacitor (Discharge capacitor before testing.)	Test capacitor. Replace if not within $\pm 10\%$ of manufacturer's rating. Replace if shorted, open, or damaged.
	Will not rotate	<p>Fan blade hitting shroud or blower wheel hitting scroll. Realign assembly.</p> <p>Units using slinger ring condenser fans must have $\frac{1}{4}$ to $\frac{5}{16}$ inch clearance to the base. If it is hitting the base, shim up the bottom of the fan motor with mounting screw(s).</p> <p>Check fan motor bearings; if motor shaft will not rotate, replace the motor.</p>
Fan motor runs intermittently	Revolves on overload.	<p>Check voltage. See limits on this page. If not within limits, call an electrician.</p> <p>Test capacitor. Check bearings. Does the fan blade rotate freely? If not, replace fan motor.</p> <p>Pay attention to any change from high speed to low speed. If the speed does not change, replace the motor.</p>
Fan motor noise.	Grommets	Check grommets; if worn or missing, replace them.
	Fan	If cracked, out of balance, or partially missing, replace it.
	Blower	If cracked, out of balance, or partially missing, replace it.
	Loose set screw	Tighten it.
	Worn bearings	If knocking sounds continue when running or loose, replace the motor. If the motor hums or noise appears to be internal while running, replace motor.

COMPLAINT	CAUSE	REMEDY
Compressor will not run, but fan motor runs.	Voltage	Check voltage. See the limits on the preceding page. If not within limits, call an electrician.
	Wiring	Check the wire connections, if loose, repair or replace the terminal. If wires are off, refer to wiring diagram for identification, and replace. Check wire locations. If not per wiring diagram, correct.
	Rotary	Check for continuity, refer to the wiring diagram for terminal identification. Replace the switch if circuit is open.
	Thermostat	Check the position of knob. If not at the coldest setting, advance the knob to this setting and restart unit. Check continuity of the thermostat. Replace thermostat if circuit is open.
	Capacitor (Discharge capacitor before servicing.)	Check the capacitor. Replace if not within $\pm 10\%$ of manufacturer's rating. Replace if shorted, open, or damaged.
	Compressor	Check the compressor for open circuit or ground. If open or grounded, replace the compressor.
	Overload	Check the compressor overload, if externally mounted. Replace if open. (If the compressor temperature is high, remove the overload, cool it, and retest.)
Compressor cycles on overload.	Voltage	Check the voltage. See the limits on the preceding page. If not within limits, call an electrician.
	Overload	Check overload, if externally mounted. Replace if open. (If the compressor temperature is high, remove the overload, cool, and retest.)
	Fan motor	If not running, determine the cause. Replace if required.
	Condenser air flow restriction	Remove the cabinet. inspect the interior surface of the condenser; if restricted, clean carefully with a vacuum cleaner (do not damage fins) or brush. Clean the interior base before reassembling.
	Condenser fins (damaged)	If condenser fins are closed over a large area on the coil surface, head pressures will increase, causing the compressor to cycle. Straighten the fins or replace the coil.

COMPLAINT	CAUSE	REMEDY
Compressor cycles on overload.	Capacitor	Test capacitor.
	Wiring	Check the terminals. If loose, repair or replace.
	Refrigerating system	Check the system for a restriction.
Insufficient cooling or heating	Air filter	If restricted, clean or replace.
	Exhaust damper door	Close if open.
	Unit undersized	Determine if the unit is properly sized for the area to be cooled.
Excessive noise.	Blower or fan	Check the set screw or clamp. If loose or missing, correct. If the blower or fan is hitting air guide, rearrange the air handling parts.
	Copper tubing	Remove the cabinet and carefully rearrange tubing not to contact cabinet, compressor, shroud, and barrier.
Auto air-swing fails.	Rotary switch.	Set the knob to HIGH COOL or LOW COOL while rocker switch is ON.
	Wiring	Check terminals. If loose, repair or replace.
	Synchronous motor.	Check the synchronous motor for open circuit.

5. SCHEMATIC DIAGRAM

5.1 CIRCUIT DIAGRAM

• MODEL : R1402

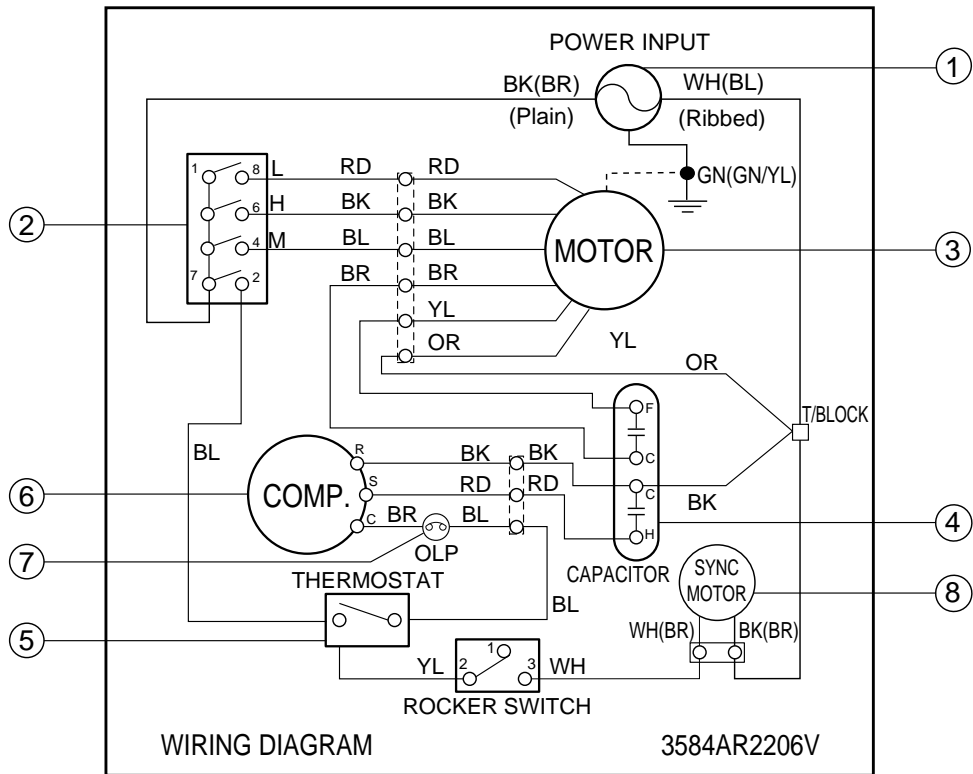

NO.	DESCRIPTION	Q'TY PER SET
1	POWER CORD	1
2	ROTARY SWITCH	1
3	FAN MOTOR	1
4	CAPACITOR	1
5	THERMOSTAT	1
6	COMPRESSOR	1
7	OVERLOAD PROTECTOR	1
8	TERMINAL BLOCK	1
9	SYNCHRONOUS MOTOR	1

• MODEL : R1802/R2102/R2402/LWN2432BAG/LWC243NSAB0

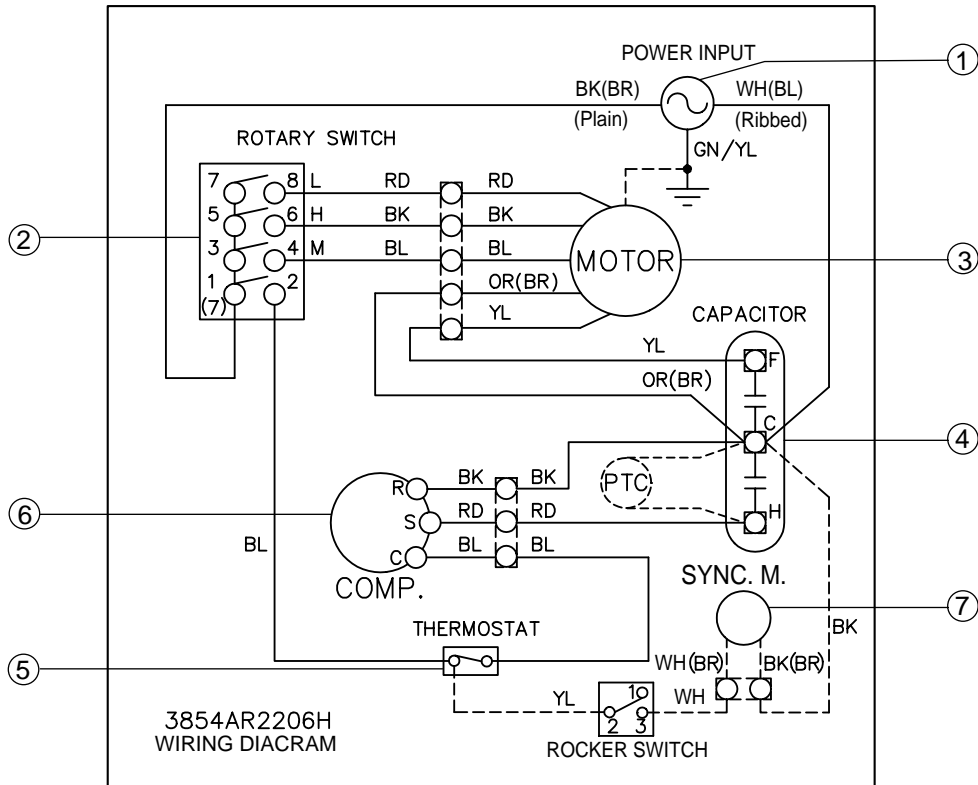

NO.	DESCRIPTION	Q'TY PER SET
1	POWER CORD	1
2	ROTARY SWITCH	1
3	FAN MOTOR	1
4	CAPACITOR	1
5	THERMOSTAT	1
6	COMPRESSOR	1
7	SYNCHRONOUS MOTOR	1

• MODEL : R1803/R1804/R2103/R2403, LWM1836BAG/BAS/BCG, Y5USC18-6A, Y5USC24-6A, LWN2432BCG

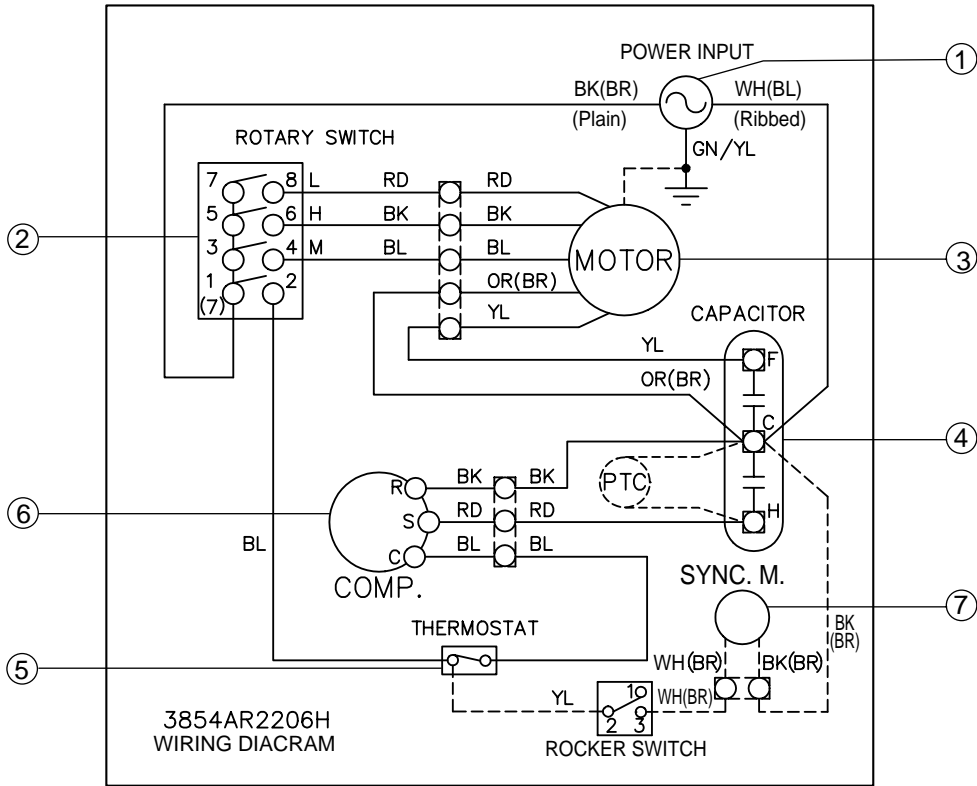

NO.	DESCRIPTION	Q'TY PER SET
1	POWER CORD	1
2	ROTARY SWITCH	1
3	FAN MOTOR	1
4	CAPACITOR	1
5	THERMOSTAT	1
6	COMPRESSOR	1
7	SYNCHRONOUS MOTOR	1

• MODEL :R1801H/R1803H

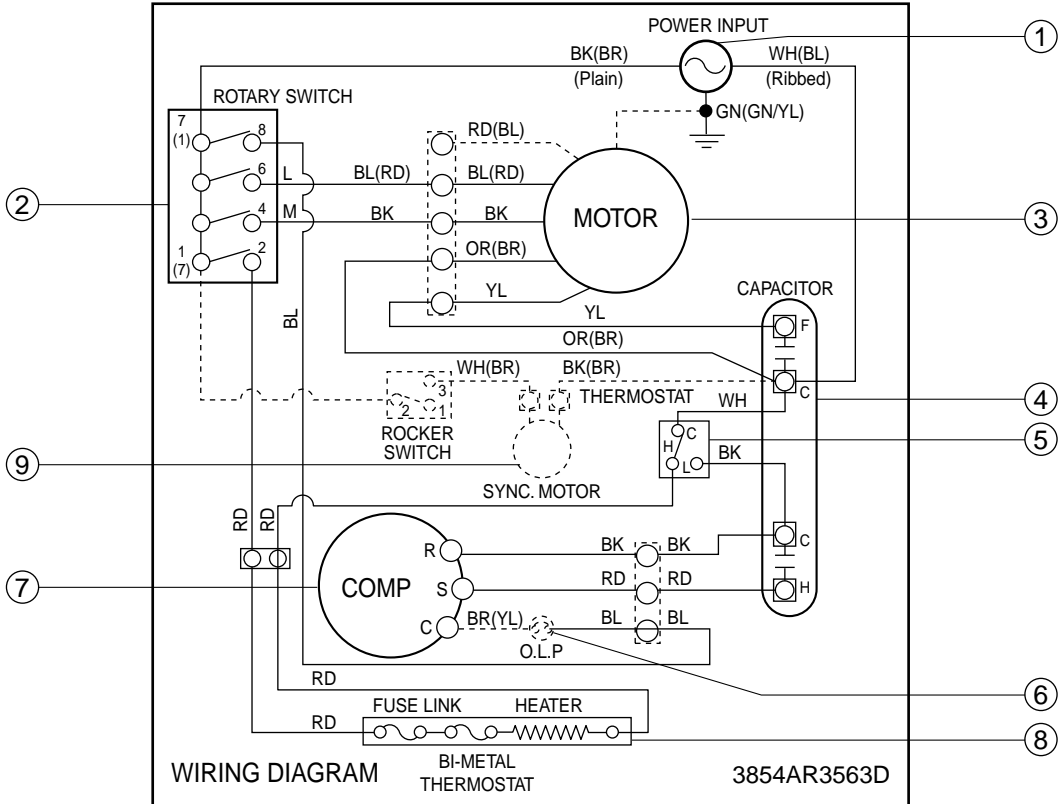

NO.	DESCRIPTION	Q'TY PER SET
1	POWER CORD	1
2	ROTARY SWITCH	1
3	FAN MOTOR	1
4	CAPACITOR	1
5	THERMOSTAT	1
6	OVERLOAD PROTECTOR	1
7	COMPRESSOR	1
8	ELECTRIC HEATER	1
9	SYNCHRONOUS MOTOR	1

• MODEL :M1802/M1803R

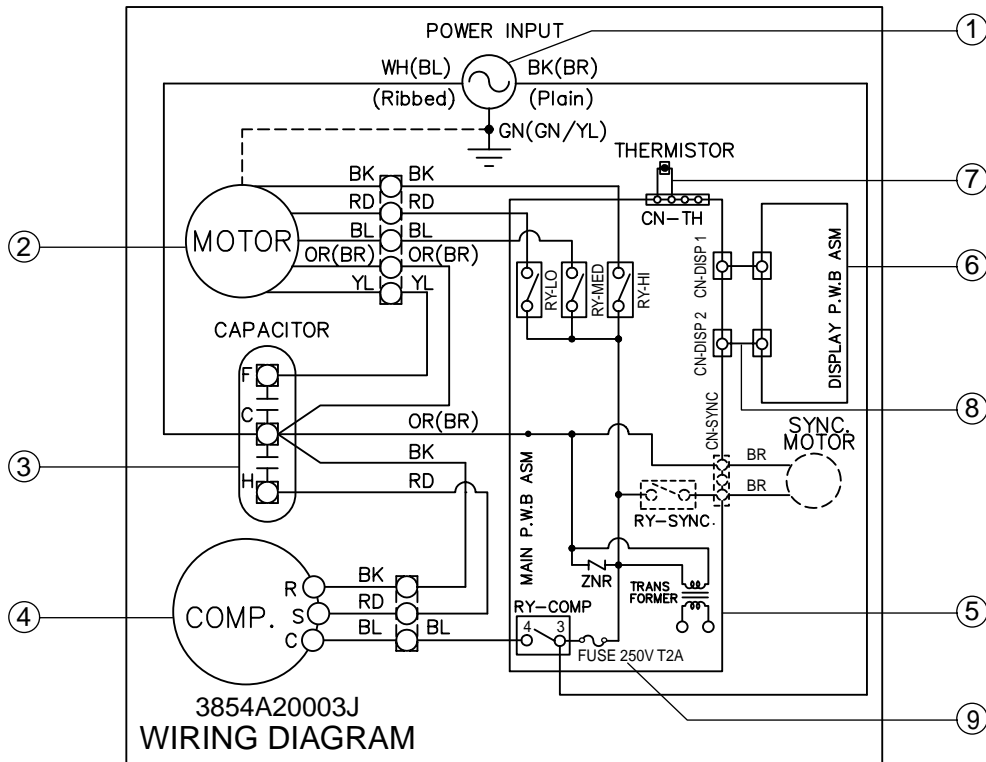

NO.	DESCRIPTION	Q'TY PER SET
1	POWER CORD	1
2	FAN MOTOR	1
3	CAPACITOR	1
4	COMPRESSOR	1
5	MAIN PWB ASM	1
6	DISPLAY PWB ASM	1
7	THERMISTOR ASM	1
8	CONNECTOR	1
9	FUSE	1

5.2. ELECTOINC CONTROL DEVICE

• MODEL : M1802

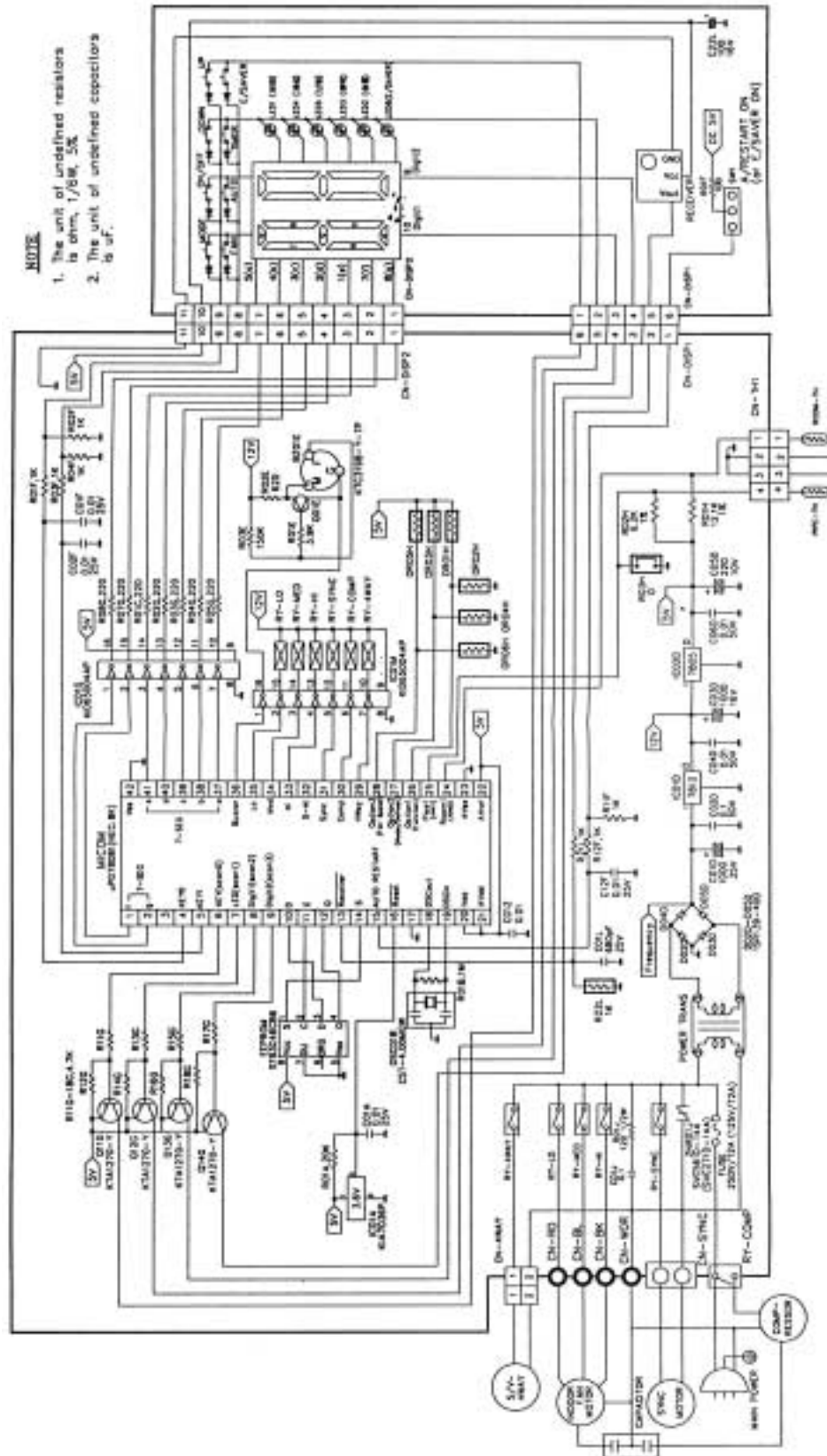

• MODEL : M1803R

NOTE

1. The unit of undefined resistors is ohm, 1/6W, 5%.
2. The unit of undefined capacitors is uF.

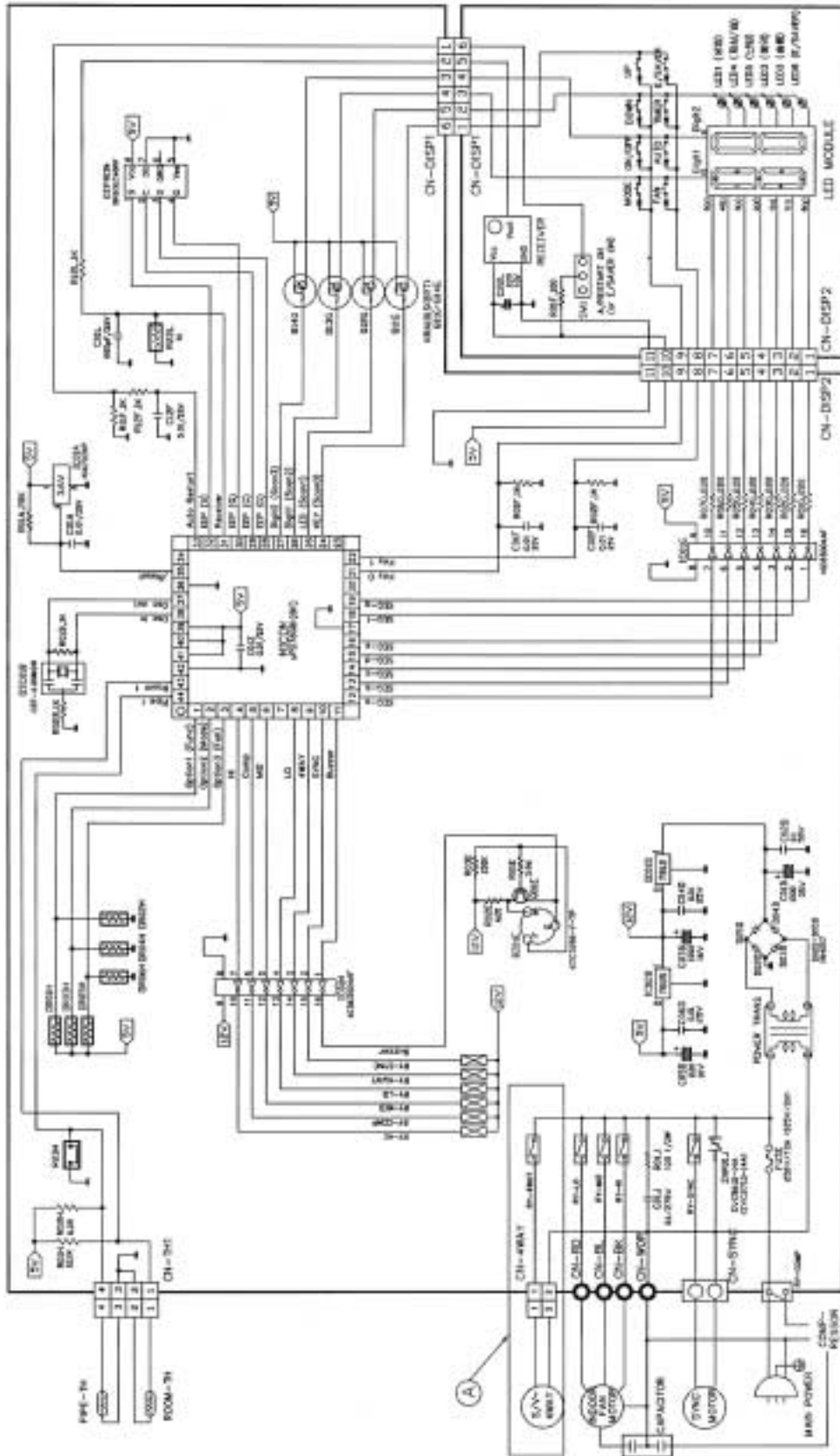

5.3. COMPONENTS LOCATION (FOR MAIN P.C.B ASM)

• MODEL : M1802

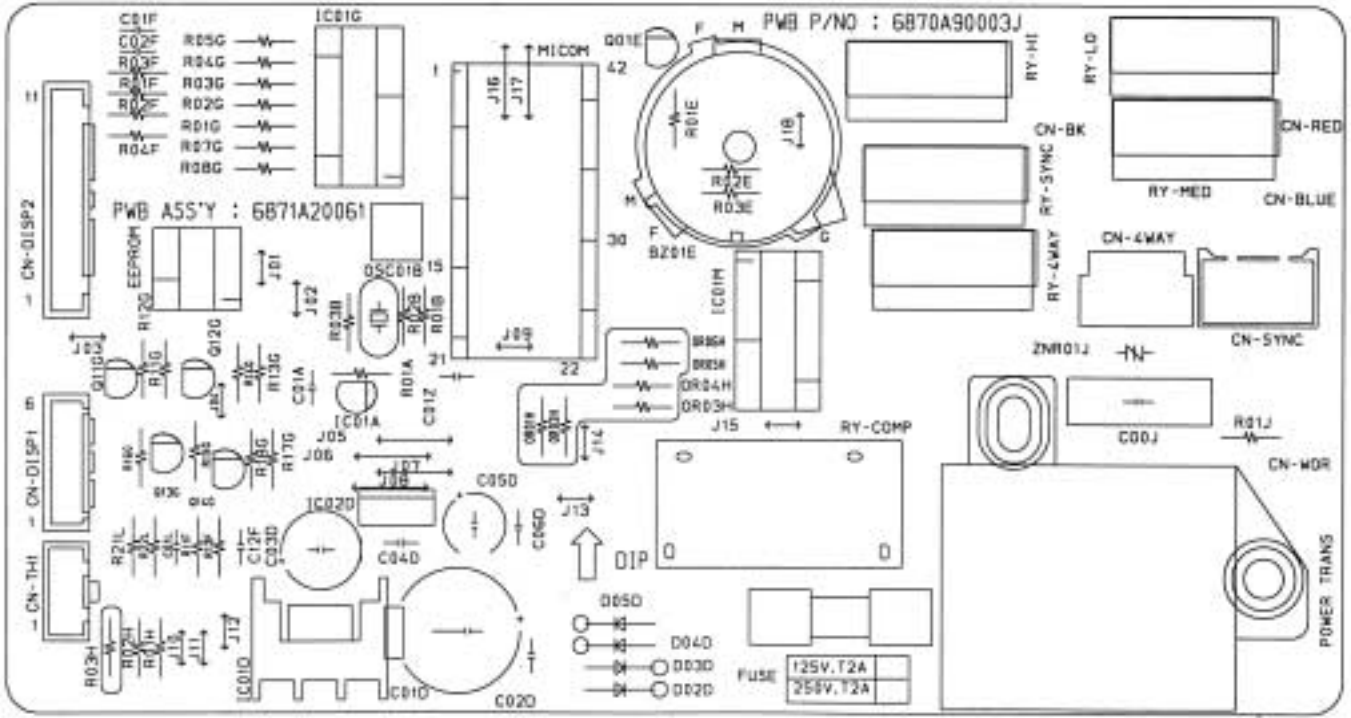

• MODEL : M1803R

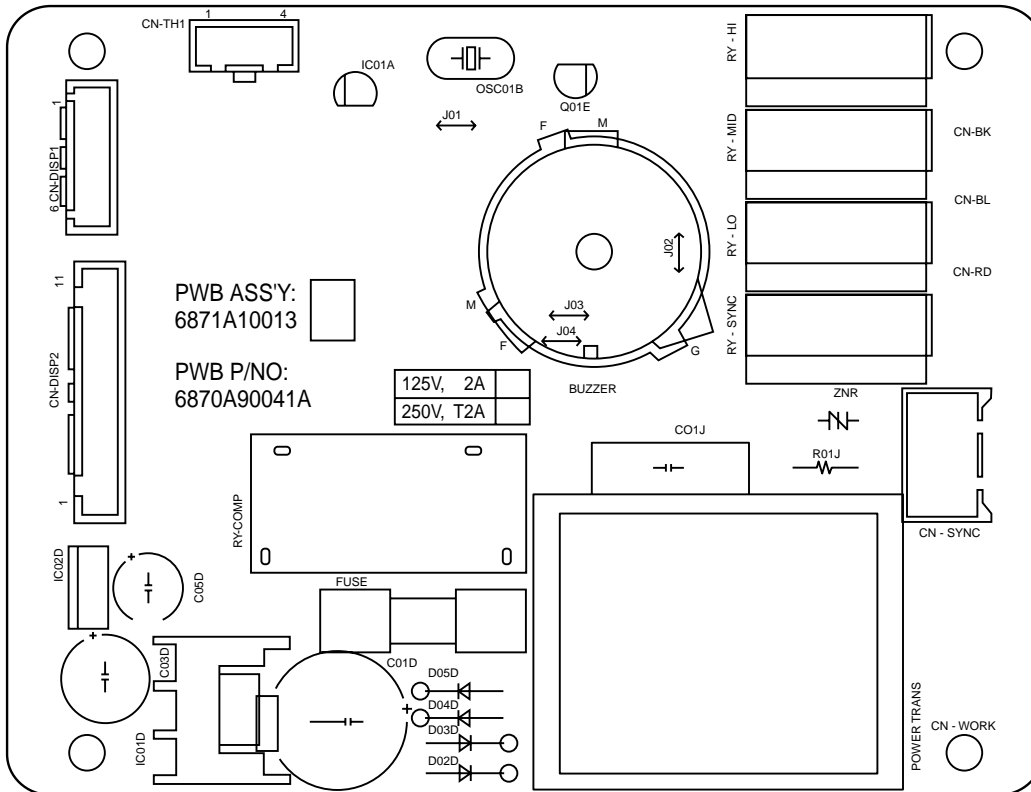

5.4. COMPONENTS LOCATION (FOR DISPLAY P.C.B ASM)

• MODEL : M1802

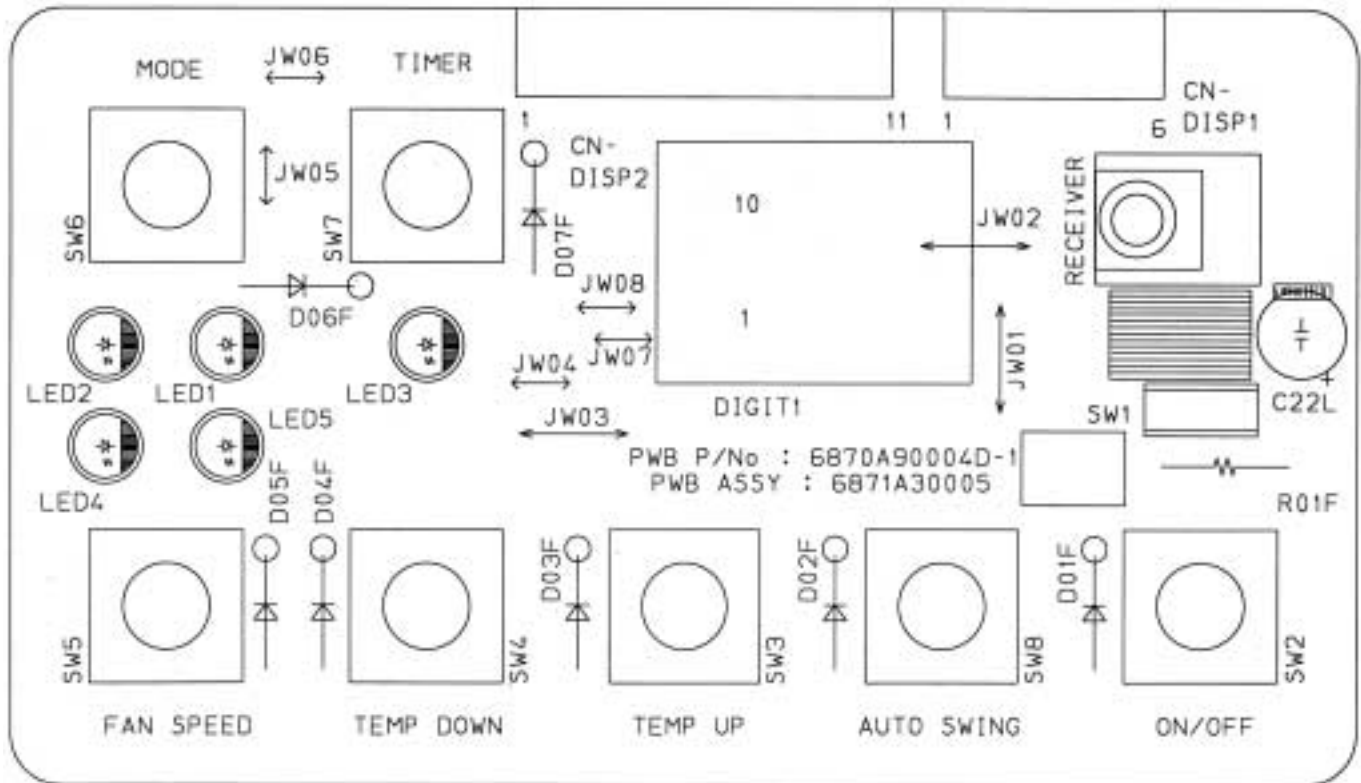

• MODEL : M1803R

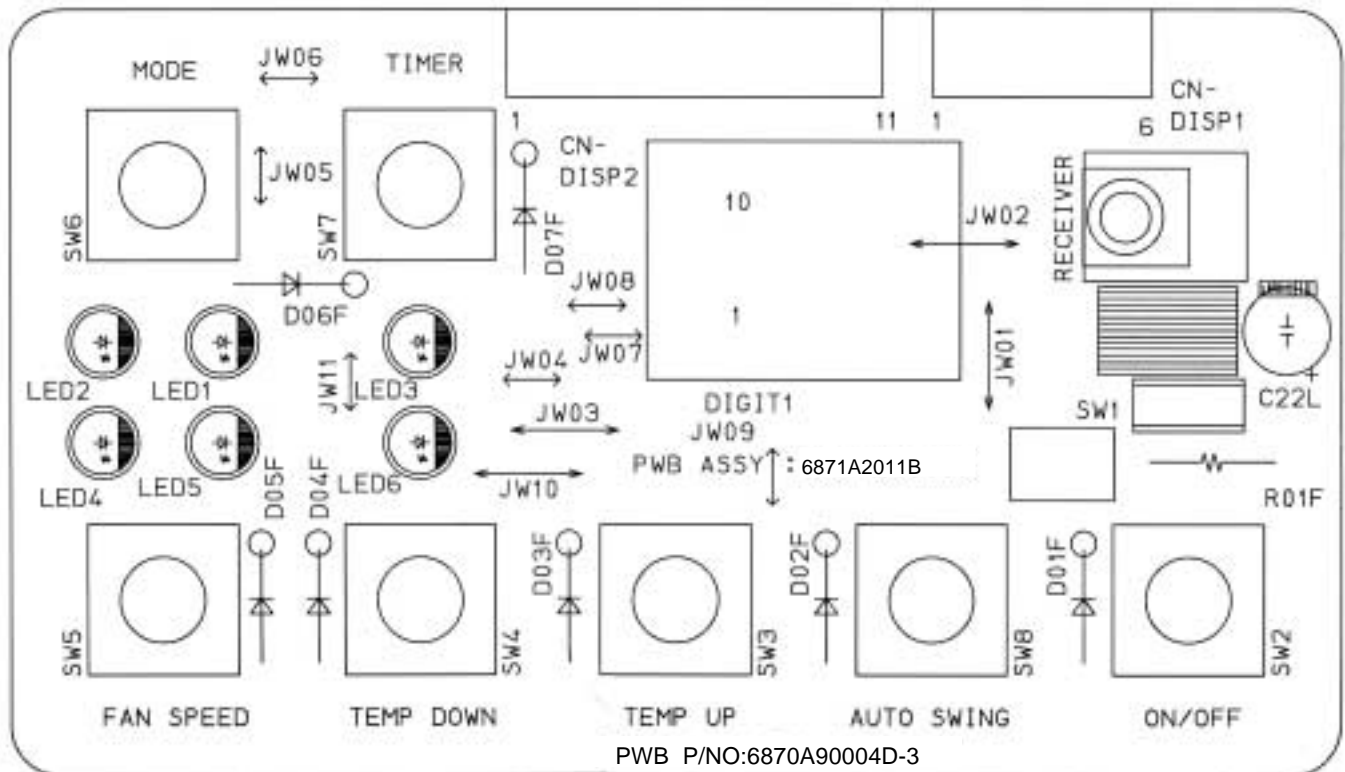

PWB P/NO:6870A90004D-3

6. EXPLODED VIEW

• MODEL: R1402/R1802/R2102/R1801H/M1802/R1803/R1804/R2103/R1803H/M1803R
LWM1836BAG/LWM1836BAS/Y5USC18-6A/LWM1836BCG

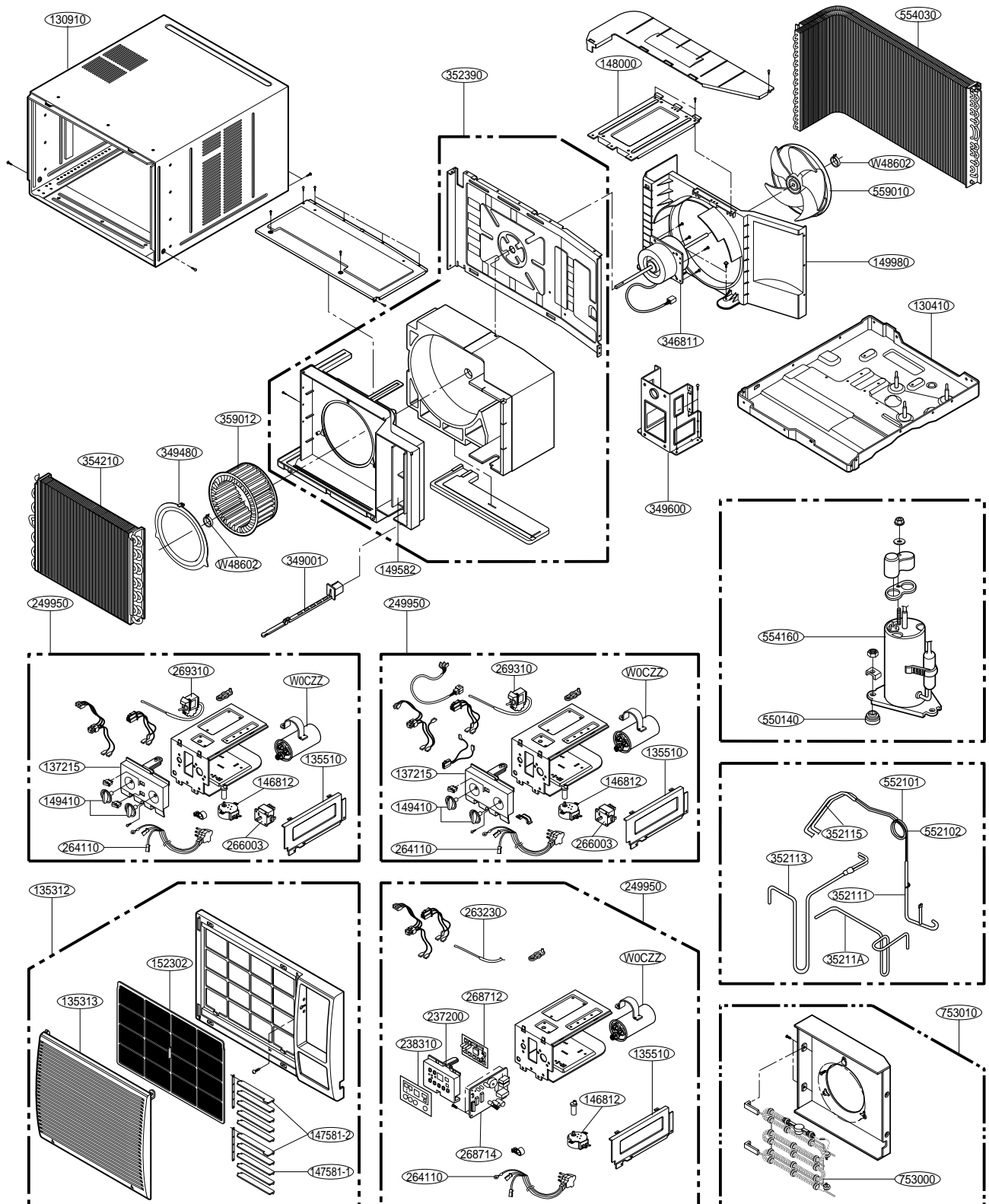

• MODEL: R2402/R2403/Y5USC24-6A/LWN2432BCG/LWN2432BAG/LWC243NSAB0

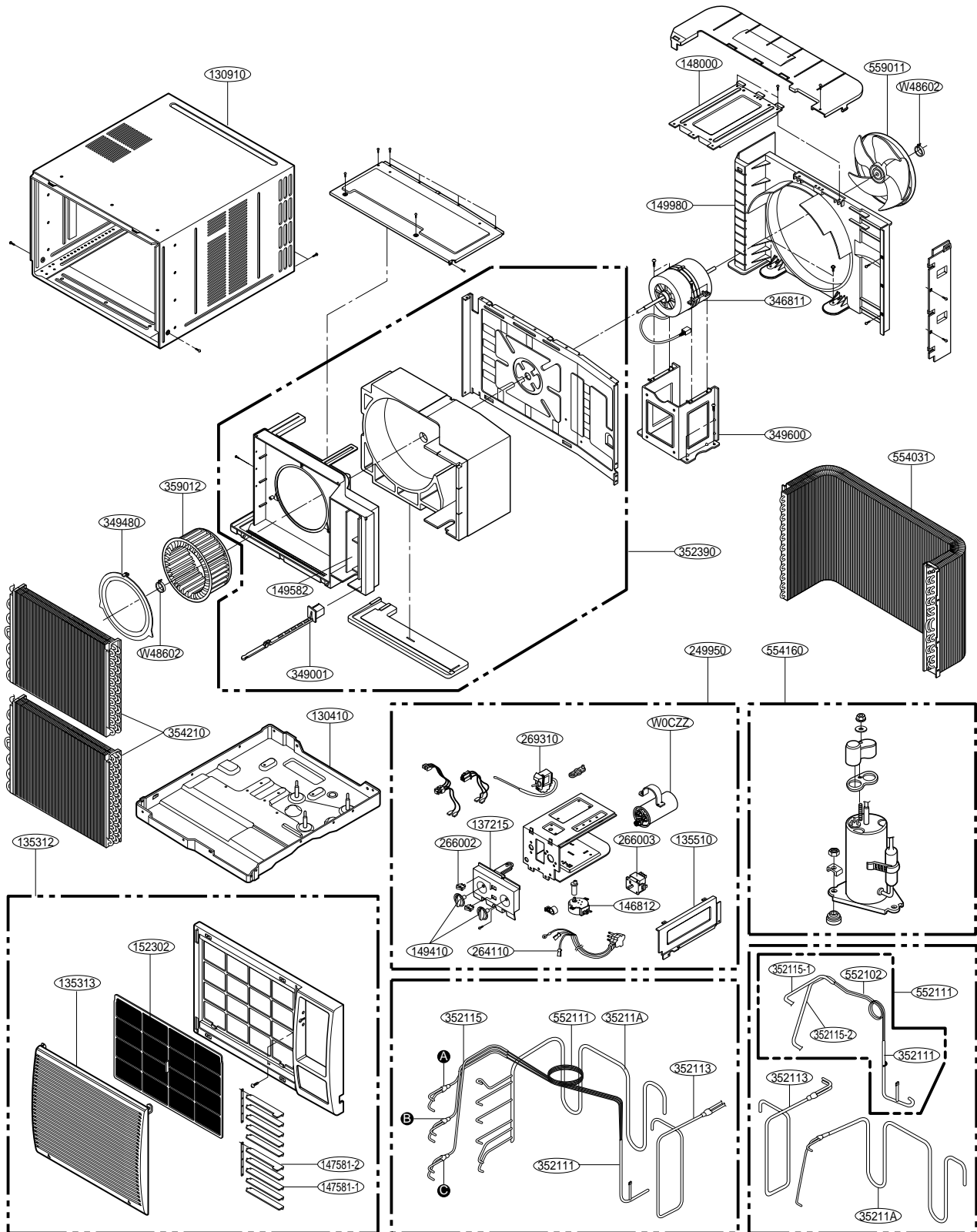

7. REPLACEMENT PARTS LIST

R: Service Parts

LOCATION NO.	DESCRIPTION	PART NO.						REMARK
		R1402	R1802	R1803	R1804	R2102	R2103	
130410	BASE ASSEMBLY, SINGLE	3041A30002B				3041A30001H		R
130910	CABINET ASSEMBLY, SINGLE	3091AR6057A				3091AR6056A		R
135312	GRILLE ASSEMBLY, FRONT(SINGLE)	3531A20005C						R
135313	GRILLE ASSEMBLY, INLET	3530AR1604A						R
135510	COVER ASSEMBLY, CONTROL	3551A30015A						R
137215	PANEL ASSEMBLY, CONTROL	3721A20002B						R
146812	MOTOR ASSEMBLY, SYNC.	2H01102D	2H01102A					R
147581-1	LOUVER, HORIZONTAL	4758AR7264A						R
147581-2	LOUVER, HORIZONTAL	4758AR7278A						R
147582	LOUVER, VERTICAL	4758AR6157A						R
148000	BRACE	4800AR7272A			4800AR7271A			R
149410	KNOB ASSEMBLY	4941A30001A						R
149980	SHROUD	4998AR1597A						R
152302	FILTER(MECH), A/C	5231AR6159A						R
249950	CONTROL BOX ASSEMBLY	4995A20005N	4995A20005P	4995A20005P		4995A20057Z	4995A20057Z	
264110	POWER CORD ASSEMBLY	2H00677S	2H00677Q					R
266003	SWITCH, ROTARY	2H00598E						R
269310	THERMOSTAT ASSEMBLY	2H01109L						R
346811	MOTOR ASSEMBLY, SINGLE	4681AR6033J	4681AR6033K			4681AR6033M		R
349001	DAMPER, VENTILATION	4900AR7265A						R
349480	ORIFICE	4948AR7241A						R
349600	MOUNT, MOTOR	4960AR1596A						R
35211A	TUBE ASSEMBLY, SUCTION	5211A30088C	5211A30210A	5211A20204A	5211A20204C	5211A30292A	5211A30292D	R
352111	TUBE ASSEMBLY, CONNECTOR	5211AR7059A	5211AR7059C			5211AR7059H		R
352113	TUBE ASSEMBLY, DISCHARGE	5211A30066C	5211A30066A	5211A30066K		5211A30293A	5211A30066L	R
352115	TUBE EVAPORATOR	5210A30009G/H	5210A30144J/K	5210A20351B/52B	5211A20433B/34B	5210A30144A/B	5210A30144J/K	R
352390	AIR GUIDE ASSEMBLY	5239A20001D						R
354210	EVAPORATOR ASSEMBLY, FIRST	5421A20017H	5421A20017G	5421A20059A	5421A20059F	5421A20017A		R
359012	FAN ASSEMBLY, BLOWER	5834AR1599A						R
550140	ISOLATOR, COMP.	4H00982C				5040A30017A		R
552101	TUBE CAPILLARY	3H03750H	3H03750Q	5210A30040N		5210A30040M	5424AR3411P	R
552102	TUBE CAPILLARY BEND	-	-	-	5211A20020P	-	-	R
554030	CONDENSER ASSEMBLY, BENT	5403A20004F	5403A20004F			5403A20004H		R
554160	COMPRESSOR	5416A20012A	5416AR20003J			5416A20013E		R
559010	FAN ASSEMBLY, AXIAL	5900AR1508A				5900AR1330A		R
567502	O.L.P	6750U-L046A	-			-		R
W0CZZ	CAPACITOR	6120AR2359Q	6120AR2194D			6120AR2194K		R
W48602	CLAMP SPRING	3H02932C						R

NOTE) *Please ensure GCSC since these parts may be changed depending upon the buyer's request.
(GCSC WEBSITE <http://biz@LGservice.com>)

LOCATION NO.	DESCRIPTION	PART NO.				REMARK
		Y5USC18-6A	LWM1836BAS	LWM1836BAG	LWM1836BCG	
130410	BASE ASSEMBLY,SINGLE	3041A30002B				R
130910	CABINET ASSEMBLY,SINGLE	3091AR6057B				R
135303	GRILLE,INLET	3530A10005A	3530A10070A	3530AR1604A		R
135312	GRILLE ASSEMBLY,FRONT(SINGLE)	3531A20073H	3531A20073E	3531A20005L	3531A20005A	R
135510	COVER ASSEMBLY,CONTROL(SINGLE)	3551A30015A				R
137215	PANEL ASSEMBLY,CONTROL	3721A20058E	3721A20002B			R
146812	MOTOR ASSEMBLY,SYNC.	2H01102A				R
147581-1	LOUVER,HORIZONTAL	4758AR7264A	4758AR7264A	4758AR7264A		R
147581-2	LOUVER,HORIZONTAL	4758AR7278A	4758AR7278A	4758AR7278A		R
147582	LOUVER,VERTICAL	4758AR6157A				R
148000	BRACE	4800AR7272A				R
149410	KNOB ASSEMBLY	4941A30001G	4941A30001A			R
149980	SHROUD	4998AR1597A				R
152302	FILTER ASSEMBLY,A/C	5231AR6159A				R
249950	CONTROL BOX ASSEMBLY,SINGLE	4995A20109C	4995A20097P	4995A20097D	4995A20097P	R
264110	POWER CORD ASSEMBLY	2H00677Q				R
266002	SWITCH,ROCKER	2H01316C				R
266003	SWITCH,ROTARY	2H00598E				R
269310	THERMOSTAT ASSEMBLY	2H01109L				R
346811	MOTOR ASSEMBLY,SINGLE	4681AR6033K				R
349001	DAMPER,VENTILATION	4900AR7265A				R
349480	ORIFICE	4948A30006A				R
349600	MOUNT,MOTOR	4960AR1596A				R
352111	TUBE ASSEMBLY,CONNECTOR	5211AR7059A				R
352113	TUBE ASSEMBLY,DISCHARGE SINGLE	5211A30066K				R
352115	TUBE ASSEMBLY,EVAPORATOR IN	5211A20433B				R
352115	TUBE ASSEMBLY,EVAPORATOR IN	5211A20434B				R
35211A	TUBE ASSEMBLY,SUCTION SINGLE	5211A20204C				R
352390	AIR GUIDE ASSEMBLY	5239A20001J				R
354210	EVAPORATOR ASSEMBLY,FIRST	5421A20059F				R
359012	FAN ASSEMBLY,BLOWER	5834AR1599A				R
550140	ISOLATOR,COMP	4H00982C				R
552102	TUBE,CAPILLARY BEND	5211A20020P				R
554031	CONDENSER ASSEMBLY,BENT	5403A20004F	5403A20004K		5403A20004F	R
554160	COMPRESSOR	5416A20003J				R
559010	FAN ASSEMBLY,AXIAL	5900AR1508A				R
W0CZZ	CAPACITOR,DRAWING	6120AR2194D				R
W48602	CLAMP,SPRING	3H02932C				R

NOTE) *Please ensure GCSC since these parts may be changed depending upon the buyer's request.
(GCSC WEBSITE <http://biz@LGservice.com>)

LOCATION NO.	DESCRIPTION	PART NO.			REMARK
		R1801H	R1803H	LWC243NSABO	
130410	BASE ASSEMBLY, SINGLE	3041A30002B	3041A30002B	3041A30001R	R
130910	CABINET ASSEMBLY, SINGLE	3091AR6057A	3091AR6057A	3091AR6056B	R
135312	GRILLE ASSEMBLY, FRONT (SINGLE)	3531A20005H	3531A20005H	3531A20073E	R
135313	GRILLE, INLET	3530AR1603A	3530AR1603A	3530A10070A	R
135510	COVER ASSEMBLY, CONTROL	3550AR7245A	3550AR7245A	3551A30015A	R
137215	PANEL ASSEMBLY, CONTROL	3721A20002Q	3721A20002Q	3721A10011L	R
146812	MOTOR ASSEMBLY, SYNC.	2H01102A	2H01102A	2H01102A	R
147581-1	LOUVER, HORIZONTAL	4758AR7264C	4758AR7264C	4758AR7278A	R
147581-2	LOUVER, HORIZONTAL	4758AR7278C	4758AR7278C	4758AR7264A	R
147582	LOUVER, VERTICAL	4758AR6157A	4758AR6157A	4758AR6157A	R
148000	BRACE	4800AR7272A	4800AR7272A	4800AR7271A	R
149410	KNOB ASSEMBLY	4941A30001A	4941A30001A	4941A30001A	R
149980	SHROUD	4998AR1597A	4998AR1597A	4998AR1602A	R
152302	FILTER(MECH), A/C	5231AR6159A	5231AR6159A	5231AR6159A	R
249950	CONTROL BOX ASSEMBLY	4995A20051A	4995A20051A	4995A20254C	R
264110	POWER CORD ASSEMBLY	2H00677U	2H00677U	6411A20015G	R
266002	SWITCH,ROCKER	-	-	2H01316C	R
266003	SWITCH, ROTARY	2H00598F	2H00598F	2H00598E	R
269310	THERMOSTAT, ASSEMBLY	2H01127B	2H01127B	2H01109L	R
346811	MOTOR ASSEMBLY, SINGLE	4681AR6033B	4681AR6033K	4681A20043A	R
349001	DAMPER, VENTILATION	4900AR7265A	4900AR7265A	4900AR7265A	R
349480	ORIFICE	-	-	4948A30006A	R
349600	MOUNT, MOTOR	4960AR1596A	4960AR1596A	4960A10006A	R
35211A	TUBE ASSEMBLY, SUCTION	5211A30065A	5211A20204A	5211A10094A	R
352111	TUBE ASSEMBLY, CONNECTOR	5211AR7059C	5211AR7059C	5211AR7059Q	R
352113	TUBE ASSEMBLY, DISCHARGE	5211A30066A	5211A30066K	5211A30325C	R
352115	TUBE EVAPORATOR	5210A30009C/D	5210A20351B/52B	5210A30144A/B	R
352390	AIR GUIDE ASSEMBLY	5239A20001G	5239A20001G	5239A20001J	R
354210	EVAPORATOR ASSEMBLY, FIRST	5421A20017B	5421A20059A	5421A20017A	R
359012	FAN ASSEMBLY, BLOWER	5834AR1599B	5834AR1599B	5834AR1599B	R
550140	ISOLATOR, COMP	4H00982C	4H00982C	5040A30017B	R
552101	TUBE CAPILLARY	3H03750S	5210A30040N	5425AR3147X	R
552102	TUBE,CAPILLARY BEND	-	-	5211A30296E	R
554031	CONDENSER ASSEMBLY, BENT	5403A20004F	5403A20004F	5403A20032D	R
554160	COMPRESSOR	5417AR2256E	5416AR20003J	5416A20013P	R
559010	FAN ASSEMBLY, AXIAL	5900AR1508A	5900AR1508A	5900AR1330A	R
753000	HEATER, ELECTRIC	5300AR1571B	5300AR1571B	-	R
753010	HEATER ASSEMBLY, ELECTRIC	5301A30001A	5301A30001A	-	R
W0CZZ	CAPACITOR, DRAWING	6120AR2359E	6120AR2359E	0CZZA20001P	R
W48602	CLAMP SPRING	3H02932C	3H02932C	3H02932C	R

NOTE) *Please ensure GCSC since these parts may be changed depending upon the buyer's request.
(GCSC WEBSITE <http://biz@LGservice.com>)

LOCATION NO.	DESCRIPTION	PART NO.		REMARK
		M1802	M1803R	
130410	BASE ASSEMBLY, SINGLE	3041A30002B		R
130910	CABINET ASSEMBLY, SINGLE	3091AR6057A		R
135312	GRILLE ASSEMBLY, FRONT (SINGLE)	3531A20005C		R
135313	GRILLE ASSEMBLY, INLET	3530AR1604A		R
135510	COVER ASSEMBLY, CONTROL	3550AR7245A		R
249950	PANEL ASSEMBLY, CONTROL	4995A20045W	4995A20100X	R
146812	MOTOR ASSEMBLY, SYNC.	2H01102A		R
147581-1	LOUVER HORIZONTAL	4758AR7264A		R
147581-2	LOUVER HORIZONTAL	4758AR7278A		R
147582	LOUVER VERTICAL	4758AR6157A		R
148000	BRACE	4800AR7272A		R
149980	SHROUD	4998AR1597A		R
152302	FILTER(MECH), A/C	5231AR6159A		R
237200	PANEL, CONTROL	3720AR6163A		R
238310	ESCUTCHEON	3831A10002G		R
263230	THERMISTOR ASSEMBLY	2H01109L		R
264110	POWER CORD ASSEMBLY	2H00677Q		R
268712	PWB(PCB) ASSEMBLY, DISPLAY	2H00598E	6871A20118C	R
268714	PWB(PCB) ASSEMBLY, MAIN	2H01316C	6871A10013E	R
346811	MOTOR ASSEMBLY, SINGLE	4681AR6033K		R
349001	DAMPER, VENTILATION	4900AR7265A		R
349480	ORIFICE	4948AR7241A		R
349600	MOUNT, MOTOR	4960AR1596A		R
35211A	TUBE ASSEMBLY, SUCTION	5211A30250A	5211A20204A	R
352111	TUBE ASSEMBLY, CONNECTOR	5211AR7059C		R
352113	TUBE ASSEMBLY, DISCHARGE	5211A30066A	5211A30066A	R
352115	TUBE EVAPORATOR	5210A30144J/K	5210A20351B/52B	R
354210	EVAPORATOR ASSEMBLY, FIRST	5421A20017G	5421A20059A	R
359012	FAN ASSEMBLY, BLOWER	5834AR1599A		R
550140	ISOLATOR, COMP.	4H00982C		R
552101	TUBE CAPILLARY	3H03750Q	5210A30040N	R
552102	TUBE CAPILLARY BEND	-	-	R
554030	CONDENSER ASSEMBLY, BENT	5403A20004F		R
554160	COMPRESSOR	5416AR20003J		R
559010	FAN ASSEMBLY, AXIAL	5900AR1508A		R
567502	O.L.P	-		R
W0CZZ	CAPACITOR	6120AR2194D		R
W48602	CLAMP, SPRING	3H02932C		R

NOTE) *Please ensure GCSC since these parts may be changed depending upon the buyer's request.
(GCSC WEBSITE <http://biz@LGservice.com>)

LOCATION NO.	DESCRIPTION	PART NO.					REMARK
		R2402	R2403	Y5USC24-6A	LWN2432BCG	LWN2432BAG	
130410	BASE ASSEMBLY, SINGLE	3041A30001R					R
130910	CABINET ASSEMBLY, SINGLE	3091AR6056A		3091AR6056B			R
135312	GRILLE ASSEMBLY, FRONT (SINGLE)	3531A20005C	3531A20005B	3531A20005A	3531A20005L		R
135313	GRILLE ASSEMBLY, INLET	3530AR1604A	3531A20073H	3530AR1604A	3530AR1604A		R
135510	COVER ASSEMBLY, CONTROL	3551A30015A					R
137215	PANEL ASSEMBLY, CONTROL	3721A20002B	3721A20058E	3721A20002B	3721A20002A		R
146812	MOTOR ASSEMBLY, SYNC.	2H01102A					R
147581-1	LOUVER HORIZONTAL	4758AR7264A					R
147581-2	LOUVER HORIZONTAL	4758AR7278A					R
147582	LOUVER, VERTICAL	4758AR6157A					R
148000	BRACE	4800AR7271A					R
149410	KNOB ASSEMBLY	4941A30001A	4941A30001G	4941A30001A			R
149980	SHROUD	4998AR1602A					R
152302	FILTER(MECH), A/C	5231AR6159A					R
249950	CONTROL BOX ASSEMBLY	4995A20065K	4995A20065V	4995A20065X	4995A20254A		R
264110	POWER CORD ASSEMBLY	2H00677U				6411A20015G	R
266002	SWITCH, ROCKER	-			2H01316C		R
266003	SWITCH, ROTARY	2H00598E					R
269310	THERMOSTAT ASSEMBLY	2H01109L					R
346811	MOTOR ASSEMBLY, SINGLE	4681A20011C	4681A20043A				R
349001	DAMPER, VENTILATION	4900AR7265A					R
349480	ORIFICE	4948A30006A					R
349600	MOUNT, MOTOR	4960AR2895A	4960A10006A				R
352111	TUBE ASSEMBLY, CONNECTOR	5211AR7059J	5211AR7059Q			5211AR7059X	R
352113	TUBE ASSEMBLY, DISCHARGE	5211A30325A	5211A30325C				R
35211A	TUBE ASSEMBLY, SUCTION	5211A20159A	5421A10094A				R
352115	TUBE EVAPORATOR	5211A20162A/B/C	-				R
352390	AIR GUIDE ASSEMBLY	5239A20001J					R
354210	EVAPORATOR ASSEMBLY, FIRST	5421A20052A	5421A20017A				R
359012	FAN ASSEMBLY, BLOWER	5834AR1599A		5834AR1599B			R
552102	TUBE CAPELLARY, BEND	-	5211A30296E				R
552111	TUBE CAPELLARY	5210A30040N	-				R
554031	CONDENSER ASSEMBLY, BENT	5403A20032B				5403A20032D	R
554160	COMPRESSOR	5416A20013G	5416A20013P				R
559010	FAN ASSEMBLY, AXIAL	5900AR1330A					R
W0CZZ	CAPACITOR	6120AR2194Q	0CZZA20001P				R
W48602	CLAMP SPRING	3H02932C					R
W52106-1	TUBE, EVAPORATOR	-	5210A30144B	5210A30144A	5210A30144B		R
W52106-2	TUBE, EVAPORATOR	-	5210A30144A				R

NOTE) *Please ensure GCSC since these parts may be changed depending upon the buyer's request.

(GCSC WEBSITE <http://biz@LGservice.com>)

MEMO

A series of horizontal dotted lines for writing.

MEMO

MEMO body containing horizontal dashed lines for writing.



P/No.: 3828A20140A

January, 2005
Printed in Korea