

This Owner's Manual is provided and hosted by [Appliance Factory Parts](#).

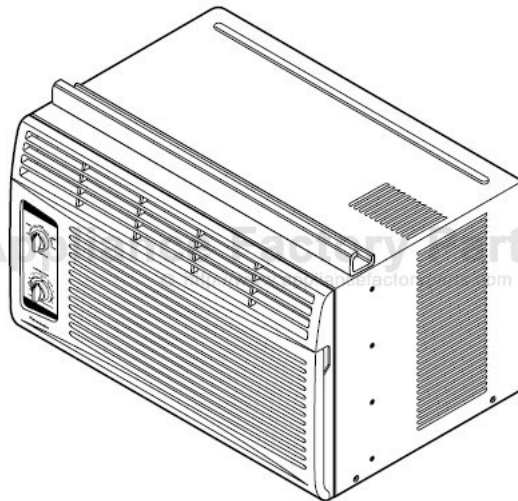

# PANASONIC CW-C53GK Owner's Manual

[Shop genuine replacement parts for PANASONIC  
CW-C53GK](#)



[Find Your PANASONIC Air Conditioner Parts - Select From 287 Models](#)

----- Manual continues below -----

# Service Manual

Room Air Conditioner

**CW-C53GK**  
**CW-C53HU**

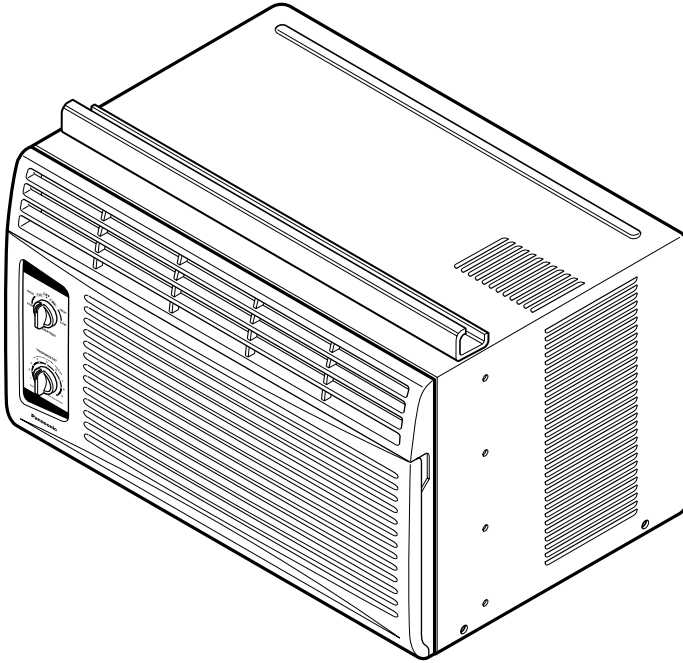

**⚠ WARNING**

This service information is designed for experienced repair technicians only and is not designed for use by the general public. It does not contain warnings or cautions to advise non-technical individuals of potential dangers in attempting to service a product. Products powered by electricity should be serviced or repaired only by experienced professional technicians. Any attempt to service or repair the product or products deal with in this service information by anyone else could result in serious injury or death.

**Panasonic<sup>®</sup>**

© 2002 Matsushita Electric Industrial co., Ltd.  
All rights reserved. Unauthorized copying and distribution is violation of law.

# CONTENTS

<b>1. PREFACE</b> .....	3
1.1 FEATURES.....	3
1.2 SPECIFICATIONS .....	3
1.3 LOCATIONS OF CONTROLS .....	4
1.4 SAFETY PRECAUTIONS .....	4
1.5 INSULATION RESISTANCE TEST .....	4
<b>2. DISASSEMBLY INSTRUCTIONS</b> .....	5
2.1 MECHANICAL PARTS .....	5
2.1.1 FRONT GRILLE .....	5
2.1.2 CABINET.....	5
2.1.3 CONTROL BOARD.....	5
2.2 AIR HANDLING PARTS .....	6
2.2.1 AIR GUIDE UPPER .....	6
2.2.2 ORIFICE, TURBO FAN AND FAN .....	6
2.2.3 MOTOR .....	7
2.2.4 AIR GUIDE .....	7
2.3 ELECTRICAL PARTS .....	7
2.3.1 OVERLOAD PROTECTOR .....	7
2.3.2 COMPRESSOR .....	8
2.3.3 CAPACITOR .....	8
2.3.4 THERMOSTAT .....	8
2.3.5 ROTARY SWITCH.....	8
2.3.6 POWER CORD .....	9
2.4 REFRIGERANT CYCLE .....	9
2.4.1 CONDENSER .....	9
2.4.2 EVAPORATOR .....	10
2.4.3 CAPILLARY TUBE .....	10
<b>3. INSTALLATION</b> .....	12
3.1 SELECT THE BEST LOCATION .....	12
3.2 HOW TO INSTALL .....	12
3.3 ELECTRICAL DATA .....	15
<b>4. TROUBLESHOOTING GUIDE</b> .....	15
4.1 OUTSIDE DIMENSIONS.....	15
4.2 PIPING SYSTEM .....	16
4.3 TROUBLESHOOTING GUIDE .....	17
<b>5. CIRCUIT DIAGRAM</b> .....	22
<b>6. EXPLODED VIEW</b> .....	23
<b>7. SERVICE PARTS LIST</b> .....	24

# 1. PREFACE

This service manual provides various service information, including the mechanical and electrical parts, etc. This room air conditioner was manufactured and assembled under a strict quality control system. The refrigerant is charged at the factory. Be sure to read the safety precautions prior to servicing the unit.

## 1.1 FEATURES

- DESIGNED FOR COOLING ONLY
- POWERFUL AND INCREDIBLE COOLING
- BUILT-IN ADJUSTABLE THERMOSTAT
- WASHABLE ONE-TOUCH FILTER
- COMPACT SIZE

## 1.2 SPECIFICATIONS

ITEMS	MODELS	CW-C53GK	CW-C53HU
COOLING CAPACITY (BTU/h)		5,250	5,200
POWER SUPPLY (Phase, V, Hz)		1ø, 115V, 60Hz	
INPUT (W)		540	480
OPERATING CURRENT (AMP.)		5.0	4.4
REFRIGERANT CONTROL		CAPILLARY TUBE	
REFRIGERANT CHARGE (R-22)		220g(7.8 Oz)	330g(11.6 Oz)
INSIDE FAN		TURBO	
OUTSIDE FAN		PROPELLER FAN WITH SLINGER RING	
AIR DISCHARGE		2-WAY (RIGHT AND LEFT)	
CHASSIS		TOP-DOWN	
PROTECTOR		<ul style="list-style-type: none"> <li>• OVERLOAD PROTECTOR FOR COMPRESSOR</li> <li>• INTERNAL PROTECTOR FOR FAN MOTOR</li> </ul>	
TEMPERATURE CONTROL		THERMOSTAT	
ROTARY SWITCH		5 POSITIONS (LOW FAN, HIGH FAN, OFF, HIGH COOL, LOW COOL)	
FAN MOTOR		6 POLES, 19.9W	

• **NOTE:** Specifications are subject to minor change without notice for further improvement.

## 1.3 LOCATIONS OF CONTROLS

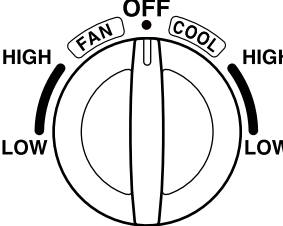
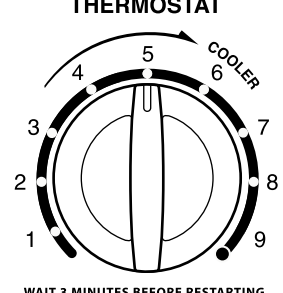
 <p style="text-align: center;"><b>OPERATION</b></p>	<p>Off– Turns air conditioner off.</p> <p>High Fan–High speed fan operation without cooling.</p> <p>Low Fan–Low speed fan operation without cooling.</p> <p>High Cool–Cooling with high speed fan operation.</p> <p>Low Cool–Cooling with low speed fan operation.</p>
 <p style="text-align: center;"><b>THERMOSTAT</b></p> <p style="text-align: center;">WAIT 3 MINUTES BEFORE RESTARTING</p>	<p>This automatically controls the temperature of the indoor air.</p> <p>Turn the knob so that the arrow points to the larger marks for greater cooling. Point the arrow to the smaller marks for more moderate cooling. (i.e. the higher the number, the greater the cooling)</p>

**CAUTION :** After switching the air conditioner from Cool to Off or Fan, wait at least 3 minutes before switching it back to Cool.

## 1.4 SAFETY PRECAUTIONS

1. When servicing, set the ROTARY SWITCH to Off and unplug the power cord.
2. Observe the original lead dress.  
If a short circuit is found, replace all parts which have been overheated or damaged by the short circuit.
3. After servicing, make an insulation resistance test to prevent the customer's exposure to shock hazards.

## 1.5 INSULATION RESISTANCE TEST

1. Unplug the power cord and connect a jumper between 2 pins (black and white).
2. The grounding conductor (green or green and yellow) is to be open.
3. Measure the resistance value with an ohm meter between the jumpered lead and each exposed metallic part on the equipment at all positions [except Off] of the ROTARY SWITCH.
4. The value should be over 1 MΩ.

## 2. DISASSEMBLY INSTRUCTIONS

### 2.1 MECHANICAL PARTS

#### 2.1.1 FRONT GRILLE

1. Disconnect the unit from source of power.
2. Remove the two knobs by pulling them off.  
Using a screwdriver, remove the screw that secures the front grille to control board.  
(See Figure 1)
3. Push the front grille up from the bottom.  
Pull the top of the front grille away from the cabinet as the top tabs lift out of their slots.  
(See Figure 2)
4. Replace the grille by placing the tabs in the slots and push the grille until it snaps into place.

Figure 1

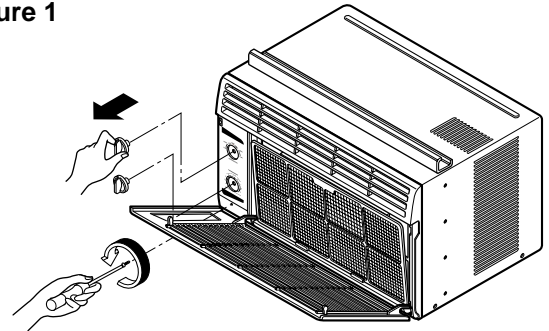

Figure 2

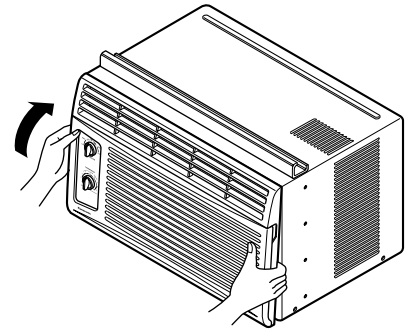

Figure 3

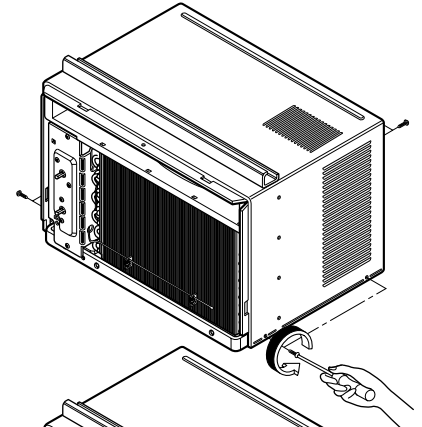

Figure 4

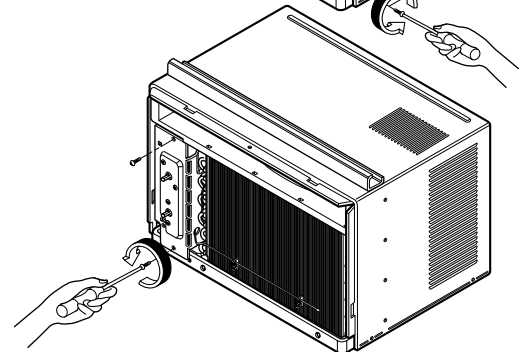
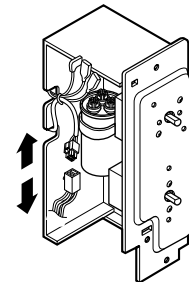

Figure 5



#### 2.1.2 CABINET

1. Disconnect the unit from the power source.
2. Remove the front grille. (Refer to section 2.1.1)
3. Remove 9 screws that secure the cabinet to the base pan and condenser. (See figure 3)
4. Lift the cabinet from the unit.
5. Re-install by referring to the procedures above.

#### 2.1.3 CONTROL BOARD

1. Disconnect the unit from the power source.
2. Remove the front grille. (Refer to Section 2.1.1)
3. Remove the cabinet. (Refer to Section 2.1.2)
4. Remove 2 screws that secure the control board to base pan and air guide. (See Figure 4)
5. Pull the control board toward yourself.

**NOTE :** Controls, wires, and capacitor are now accessible for servicing. Discharge the capacitor before servicing. See step 2.3.3 on page 8 for procedures.

6. Disconnect one housing terminal and 3 wires for the fan motor and compressor. (See Figure 5)
7. Re-install components by referring to procedures above. (Refer to wiring diagram on page 23 in this manual or inside control board.)

## 2.2 AIR HANDLING PARTS

### 2.2.1 AIR GUIDE UPPER

1. Disconnect the unit from the power source.
2. Remove the front grille. (Refer to Section 2.1.1)
3. Remove the cabinet. (Refer to Section 2.1.2)
4. Remove the control board.  
(Refer to Section 2.1.3)
5. Remove 2 screws that secure the air guide upper to air guide lower. (See Figure 6)
6. Lift air guide upper upward.
7. Re-install by referring to the procedures above.

Figure 6

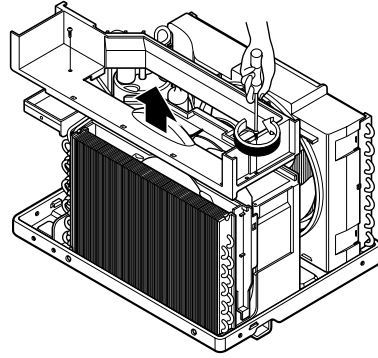

### 2.2.2 ORIFICE, TURBO FAN AND FAN

1. Disconnect the unit from the power source.
2. Remove the front grille. (Refer to Section 2.1.1)
3. Remove the cabinet. (Refer to Section 2.1.2)
4. Remove the control board.  
(Refer to Section 2.1.3)
5. Remove the air guide upper.  
(Refer to Section 2.2.1)
6. Remove 2 screws that secure the base pan to condenser. (See Figure 7)
7. Remove screw that secures the shroud to channel of condenser.
8. Press the snap area of shroud with your thumbs. This allows you to remove it from the condenser.
9. Lift the compressor upward with the evaporator and condenser. (See Figure 7)
10. Remove the orifice by pushing the snap area of the air guide blower. (See Figure 8)
11. Remove the clamp springs which are clamped to the boss of fan and turbo fan by hand plier. (See Figure 9)
12. Pull the fan and turbo fan outward.
13. Remove the shroud.
14. Re-install by referring to the procedures above.

Figure 7

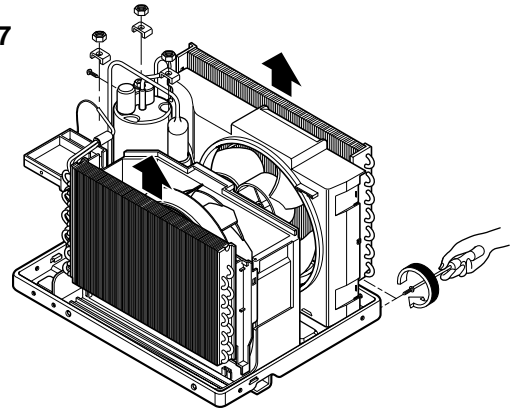

Figure 8

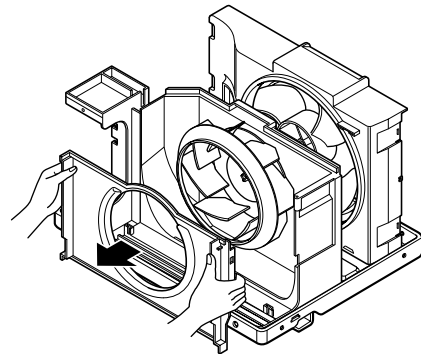
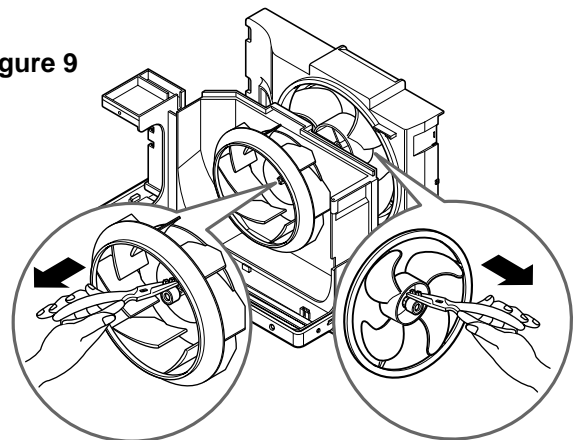

Figure 9



## 2.2.3 MOTOR

1. Disconnect the unit from the power source.
2. Remove the front grille. (Refer to Section 2.1.1)
3. Remove the cabinet. (Refer to Section 2.1.2)
4. Remove the control board.  
(Refer to Section 2.1.3)
5. Remove the air guide upper.  
(Refer to Section 2.2.1)
6. Remove the compressor, turbo fan, fan and shroud. (Refer to Section 2.2.2)
7. Remove 2 screws that secure the motor to the motor. (See figure 10)
8. Remove the motor.
9. Re-install by referring to the procedures above.

Figure 10

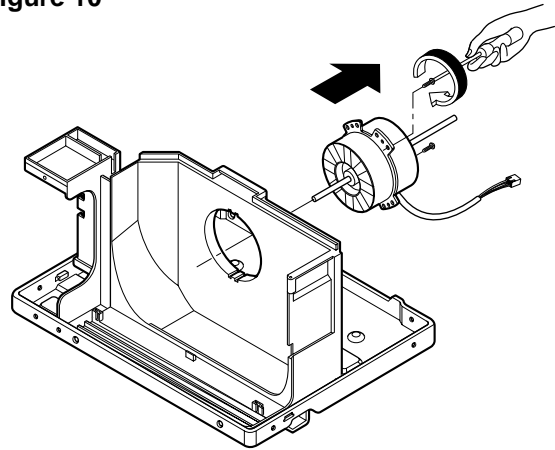

## 2.2.4 AIR GUIDE

1. Disconnect the unit from the power source.
2. Remove the front grille. (Refer to Section 2.1.1)
3. Remove the cabinet. (Refer to Section 2.1.2)
4. Remove the control board.  
(Refer to Section 2.1.3)
5. Remove the air guide upper.  
(Refer to Section 2.2.1)
6. Remove the compressor, turbo fan, fan and shroud. (Refer to Section 2.2.2)
7. Remove the motor. (Refer to Section 2.2.3)
8. Remove 2 screws that secure the air guide to the base pan. (See Figure 11)
9. Push the air guide backward and lift it upward.  
(See Figure 11)
10. Re-install by referring to the procedures above.

Figure 11

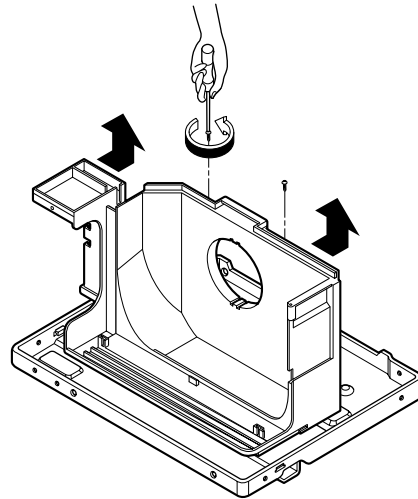

## 2.3 ELECTRICAL PARTS

### 2.3.1 OVERLOAD PROTECTOR

1. Remove the front grille and cabinet.  
(Refer to Section 2.1)
2. Remove the nut which fastens the terminal cover.
3. Remove the terminal cover.
4. Remove all the leads from the overload protector.
5. Remove the overload protector.
6. Re-install the components by referring to the removal procedure above.  
(See Figure 12 and 13)

Figure 12

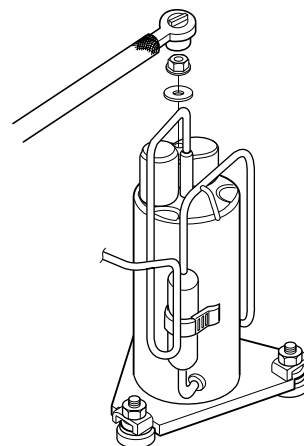
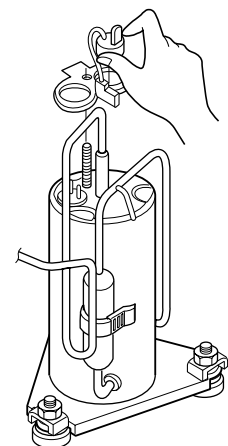

Figure 13



### 2.3.2 COMPRESSOR

1. Remove the front grille and cabinet.  
(Refer to Section 2.1)
2. Discharge the refrigerant by using a refrigerant recovery system.
3. Remove the overload protector.  
(Refer to Section 2.3.1)
4. After discharging the unit completely, unbrace the suction and discharge pipes at the compressor connections.
5. Remove 3 nuts which fasten the compressor.
6. Remove the compressor.
7. Re-install by referring to the removal procedure above. (See Figure 14)

Figure 14

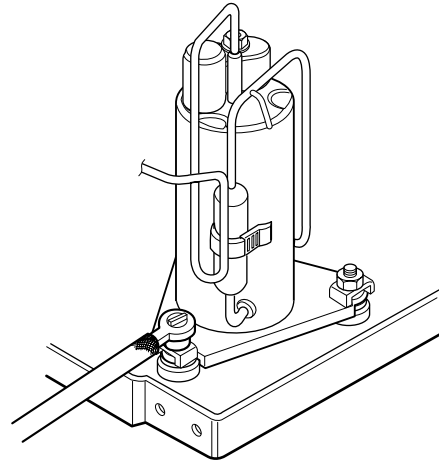

### 2.3.3 CAPACITOR

1. Remove the cabinet. (Refer to Section 2.1.2)
2. Remove the control board.  
(Refer to Section 2.1.3)
3. Discharge the capacitor by placing a 20 K $\Omega$  resistor across the capacitor terminals.
4. Remove the screw which fastens the capacitor clamp.
5. Remove all the leads of capacitor terminals.
6. Re-install the components by referring to the removal procedure above. (See Figure 15)

Figure 15

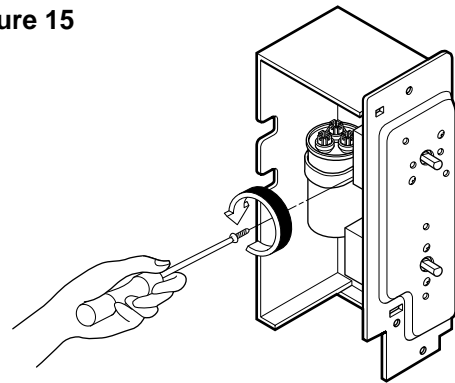

### 2.3.4 THERMOSTAT

1. Remove the cabinet. (Refer to Section 2.1.2)
2. Remove the control board.  
(Refer to Section 2.1.3)
3. Remove 2 screws which fasten the thermostat.
4. Remove all the leads of the thermostat terminals.
5. Remove the thermostat.
6. Re-install the components by referring to the removal procedure above. (See Figure 16)

Figure 16

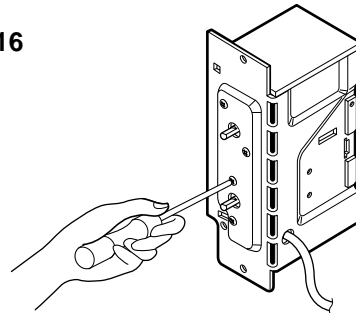

### 2.3.5 ROTARY SWITCH

1. Remove the cabinet. (Refer to Section 2.1.2)
2. Remove the control board.  
(Refer to Section 2.1.3)
3. Remove 2 screws which fasten the rotary switch.
4. Remove all the leads of the rotary switch terminals.
5. Remove the rotary switch.
6. Re-install the components by referring to the removal procedure above. (See Figure 17)

Figure 17

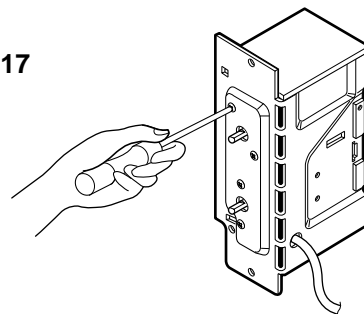

### 2.3.6 POWER CORD

1. Disconnect the unit from source of power.
2. Remove the front grille. (Refer to Section 2.1.1)
3. Remove the cabinet. (Refer to Section 2.1.2)
4. Remove a screw that secures control board to base pan. (Refer to Section 2.1.3)
5. Pulls the control board toward you.
6. Disconnect the 2 receptacles and remove the grounding screw.
7. Remove a screw securing the clip with cord to the control board.
8. Pull the power cord.
9. Re-install by referring to procedures above.

Figure 18

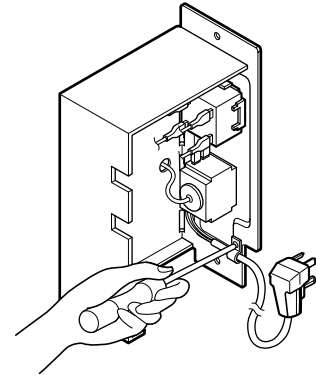

### 2.4 REFRIGERANT CYCLE

#### 2.4.1 CONDENSER

1. Remove the cabinet. (Refer to Section 2.1.2)
2. Discharge the refrigerant by using a refrigerant recovery system.
3. Remove the air guide. (Refer to Section 2.2.1)
4. Remove 2 screws which fasten the condenser.
5. After discharging the refrigerant completely, unbraid the interconnecting tube at the condenser connections.
6. Remove the condenser.
7. Re-install by referring to the procedures above.

Figure19

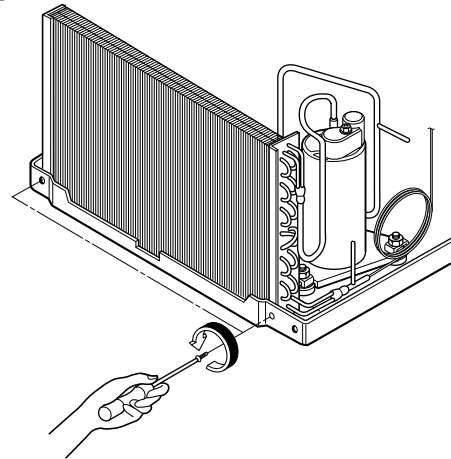

## 2.4.2 EVAPORATOR

1. Remove the cabinet.
2. Discharge the refrigerant by using a refrigerant recovery system.
3. Remove the air guide upper. (Refer to Section 2.2.1)
4. After discharging the refrigerant completely, unbrazed the interconnecting tube at the condenser connections.
5. Remove the evaporator.
6. Re-install by referring to the procedures above.

## 2.4.3 CAPILLARY TUBE

1. Remove the cabinet.
2. Discharge the refrigerant by using a refrigerant recovery system.
3. Remove the air guide upper. (Refer to Section 2.2.1)
4. After discharging the refrigerant completely, unbrazed the interconnecting tube of the capillary tube.
5. Remove the capillary tube.
6. Re-install by referring to the procedures above.

## NOTES

Replacement of the refrigeration cycle.

1. When replacing the refrigerating cycle, be sure to discharge the refrigerant by using a refrigerant recovery system.
2. After discharging the unit completely, remove the desired components, and unbrazed the pinch-off tubes.
3. Solder service valves into the pinch-off tube ports, leaving the valves open.
4. Solder the pinch-off tubes with service valves.
5. After completing the above procedures, the valve must be closed and left in place on the system for any subsequent procedures.
6. Evacuate as follows:
  - 6-1. Connect the vacuum pump, as illustrated in figure 21A.
  - 6-2. Start the vacuum pump. Slowly open manifold valves A and B with two full turns counter-clockwise and leave the valves closed. The vacuum pump is now pulling through valves A and B up to valve C by means of manifold and the entire system.

**CAUTION** : If high vacuum equipment is used, just crack valves A and B for a few minutes, then open slowly with the two full turns counter-clock-

wise. This will keep oil from foaming and being drawn into the vacuum pump.

- 6-3. Operate the vacuum pump for 20 to 30 minutes, until 600 micron vacuum is obtained. Close valves A and B and observe vacuum gauge for a few minutes. A rise in pressure would indicate a possible leak or moisture remaining in the system. With valves A and B closed, stop the vacuum pump.
- 6-4. Remove the hose from the vacuum pump and place it on the charging cylinder. See figure 23B. Open valve C. Discharge the line at the manifold connection.
- 6-5. The system is now ready for final charging.
7. Recharge as follows:
  - 7-1. Rotary compressor systems are charged from the high-side. If the total charge cannot be put in the high-side, the balance will be put in the suction line through the access valve which is installed as the system is opened.
  - 7-2. Connect the charging cylinder as shown in figure 21B. With valve C open, discharge the hose at the manifold connection.
  - 7-3. Open valve A and allow the proper charge to enter the system. Valve B is still closed.
  - 7-4. If more charge is required, the high-side will not take it. Close valve A.
  - 7-5. With the unit running, open valve B and add the balance of the charge.
    - a. Do not add the liquid refrigerant to the low-side.
    - b. Watch the low-side gauge, allow pressure to rise to 30 lbs(0.2MP).
    - c. Turn off valve B and allow the pressure to drop.
    - d. Repeat steps B and C until the balance of the charge is in the system.
  - 7-6. When the unit is operating correctly, use the pinch-off tool with the unit still running and the clamp on the pinch-off tube. Using a tube cutter, cut the pinch-off tube about 5cm(2") from the pinch-off tool. Use sil-fos solder and solder the pinch-off tube closed. Turn off the unit, allow setting for a while and then test the leakage of the pinch-off connection.

**Equipment needed:** Vacuum pump, charging cylinder, manifold gauge, brazing equipment, pinch-off tool capable of making a vapor proof seal, leak detector, tubing cutter, hand tools to remove components and service valve.

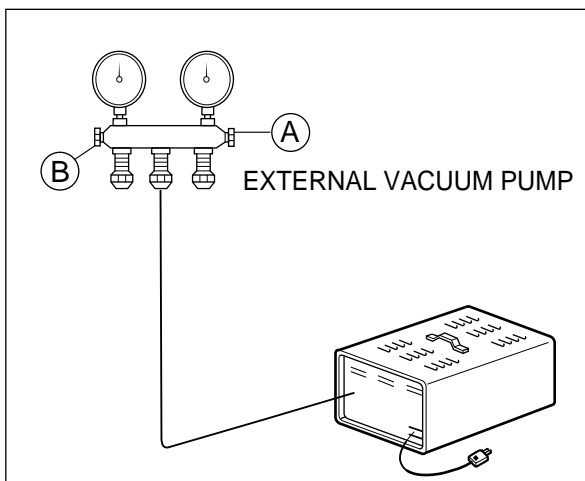
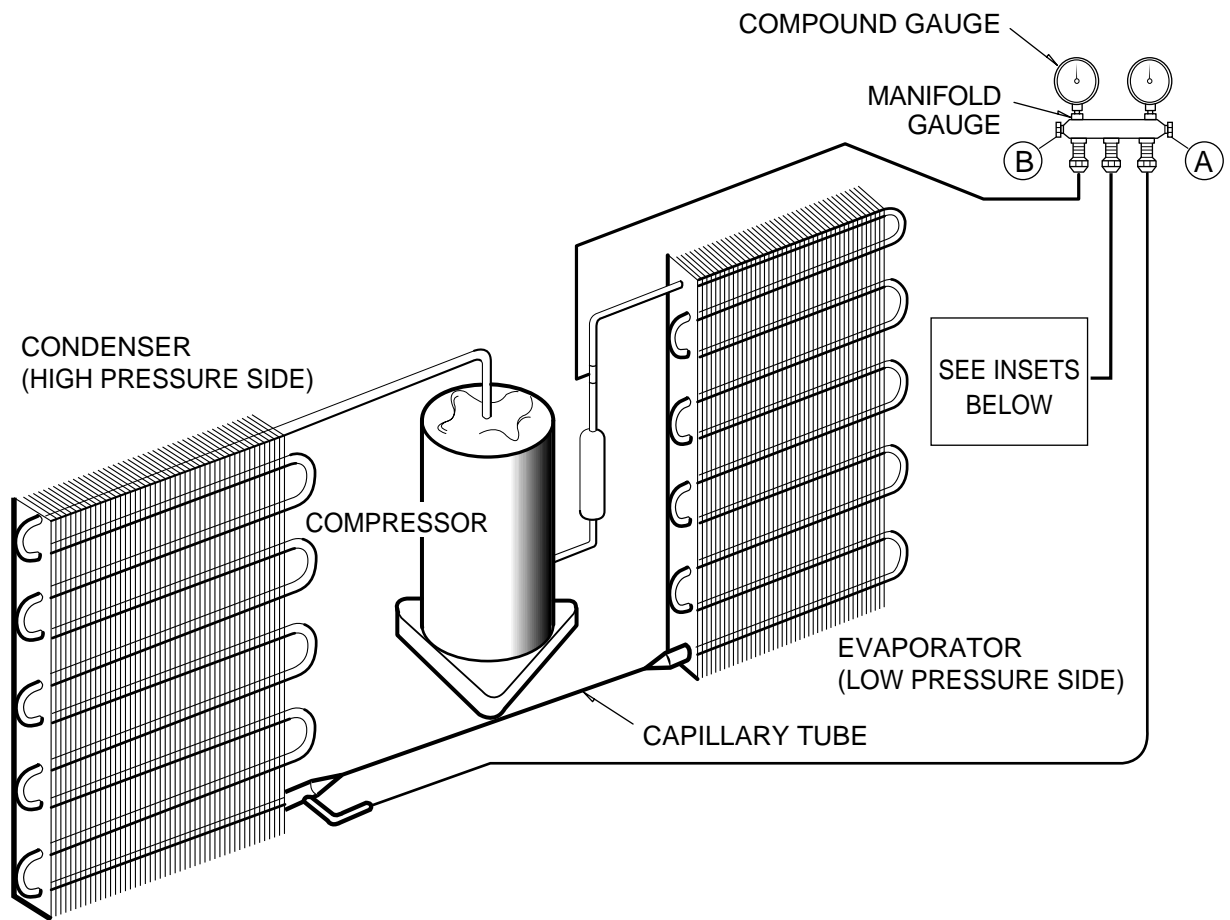

**Figure 21A-Pulling Vacuum**

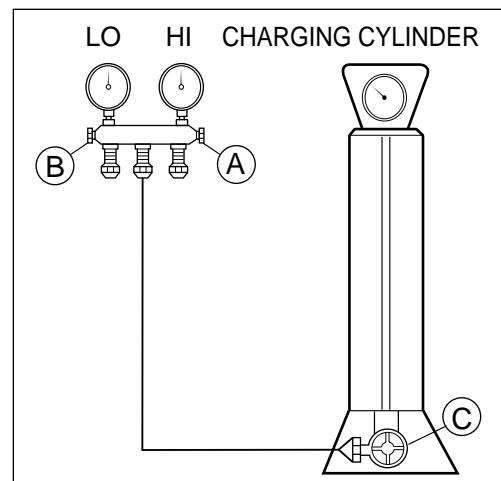

**Figure 21B-Charging**

# 3. INSTALLATION

This air conditioner is designed with a button-down chassis so it can be easily installed in a window.

## 3.1 SELECT THE BEST LOCATION

1. To prevent vibration and noise, make sure the unit is installed securely and firmly.
2. Install the unit where the sun does not shine directly on the unit.
3. The outside of the cabinet must extend outward for at least 25.4cm(10") and there should be no obstacles, such as a fence or wall, within 50.8cm(20") from the back of the cabinet because it will prevent heat radiation of the condenser. Restriction of outside air will greatly reduce the cooling efficiency of the air conditioner.

**CAUTION**

All side louvers of the cabinet must remain exposed on the outside of the structure.

4. Install the unit slanted slightly so the back is slightly lower than the front (about 6.35mm(1/4")). This will force condensed water to the outside.
5. Install the unit with the bottom about 76.2cm(30")~152.4cm(60") above the floor level.

## 3.2 HOW TO INSTALL

### 3.2.1 WINDOW REQUIREMENTS

**NOTE:** All supporting parts should be secured to firm wood, masonry, or metal.

1. This unit is designed for installation in standard double hung windows with actual opening widths of 55.88cm(22") to 91.44cm(36"). The upper and lower sash must open sufficiently to allow a clear vertical opening of 13cm from the bottom of the sash to the window stool.
2. If a storm window presents interference, fasten a 5.08cm(2") wide wood strip to the inner window sill across the full width of the sill. The wood strip should be thick enough to raise the height of the window sill so that the unit can be installed without interference by the storm window frame. See Fig. 24. Top of the wood strip should be approximately 1.9cm(3/4") higher than the storm window frame (STORM WINDOW FRAME) or wood strip (OUTDOORS) to help condensation to drain properly to the outside.
3. Install a second wood strip (approximately 15.24cm(6") long by 3.81cm(1 1/2") wide and same thickness as first strip) in the center of the outer sill flush against the back off the inner sill. This will raise the L bracket as shown Fig. 24. The thickness of the second wood strip may not be the same as the first wood strip. The thickness of the second wood strip must be defined to keep the 1.9cm(3/4") distance between the inner sill or the top of the first wood strip and the outer sill.

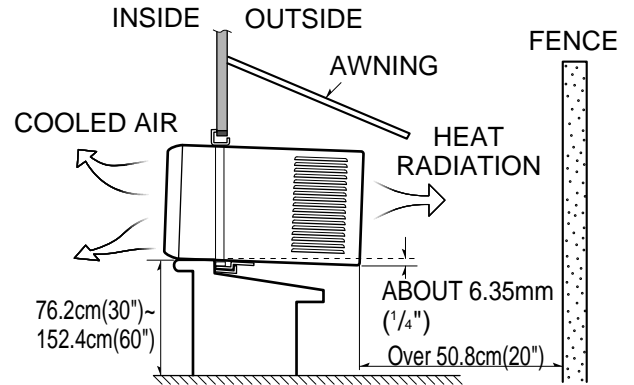

Figure 22

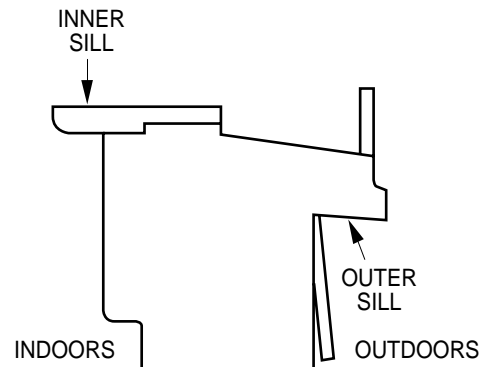

Figure 23

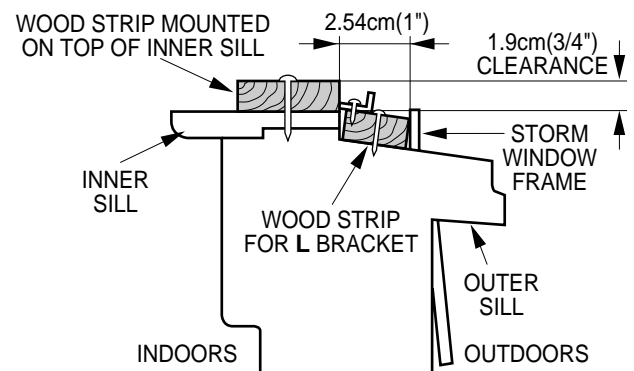
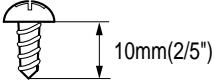
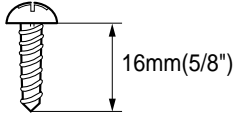
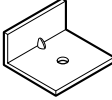

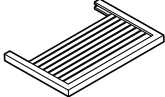





Figure 24

## Installation

HARDWARE			
TYPE A: 11EA (SHORT SCREW)	TYPE B: 4EA (WOOD SCREW)	TYPE C: 3EA (L BACKET)	DRAIN PIPE
			
TYPE D: 1EA (SEAL STRIP)	TYPE E: 1EA (SASH SEAL)	TYPE F: 2EA (GUIDE PANEL)	TYPE G: 1EA (SUPPORT BRACKET)
(Adhesive backed)	(Not adhesive backed)		
			

### 3.2.2 BEFORE INSTALLATION

1. Insert the guide panels into the guides of the air conditioner. Fasten the curtains to the unit with screws (TYPE A), as shown Fig. 25.
2. Cut the adhesive-backed seal strip (TYPE D) to the window width. Remove the backing from the seal strip and attach the seal strip to the underside of the bottom window. (Fig. 26)

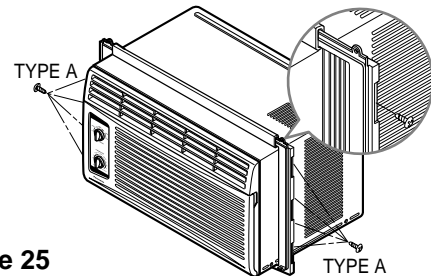

Figure 25

### 3.2.3 NOW START INSTALLATION

#### 1. LOCATING UNIT IN A WINDOW

Open the window and mark center line on the center of the inner sill, as shown in Fig. 27.

#### 2. ATTACH L BRACKET

- a. Install the L brackets behind the inner window sill, with the short side of bracket as shown. Use the 2 screws (TYPE A) provided.
- b. The bracket helps to hold unit securely in place. Be sure to place bracket edge flush against back of inner sill. See Fig. 27.

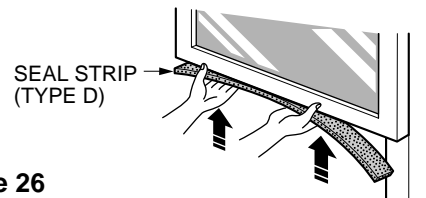

Figure 26

#### **CAUTION**

During the following step, hold unit firmly until window sash is lowered to top channel behind side panel frames. Personal injury or property damage may result if unit falls from window.

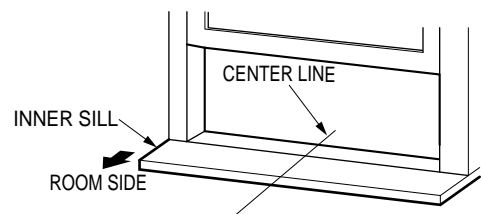
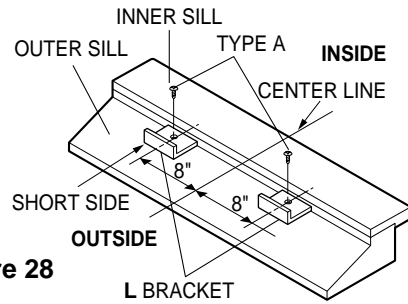

Figure 27

**3. INSTALL THE AIR CONDITIONER IN THE WINDOW**

- a. Carefully lift the air conditioner and slide it into the open window. Make sure the bottom guide of the air conditioner drops into the notches of the L bracket. See Fig. 28.

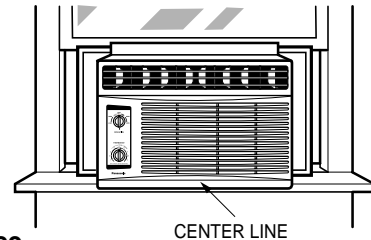

**Figure 28**

**IMPORTANT :**

When the air conditioner drops into the L bracket, the air conditioner will be centered in window opening as shown in Fig. 29.

- b. While steadying the air conditioner, carefully bring the window sash down behind the upper guide of the air conditioner, as shown in Fig. 30.



**Figure 29**

**4. SECURE THE GUIDE PANELS**

Extend the guide panels (TYPE F) to fill the window opening using 4 screws (TYPE B) to secure them, as shown in Fig. 31.

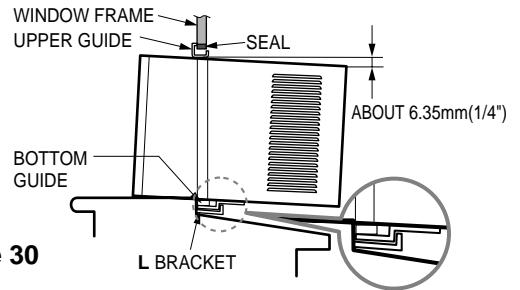

**Figure 30**

**5. INSTALL THE SASH SEAL AND SASH LOCK**

- a. Cut the sash seal (TYPE E) to the window width. Stuff the sash seal between the glass and the window to prevent air and insects from getting into the room, as shown in Fig. 31.
- b. Fasten the L bracket using a screw (TYPE A), as shown in Fig. 31.

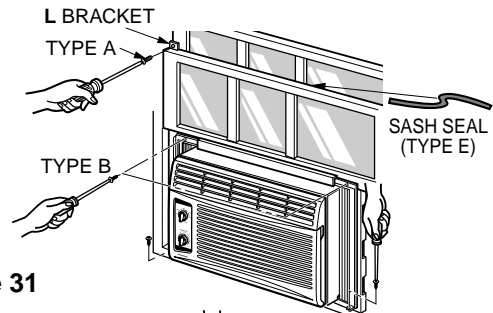

**Figure 31**

- 6. a. Remove the screws that secure the cabinet and base pan in the right side.
- b. Fasten the support bracket (TYPE G) using a removed screw. Attach the support bracket (TYPE G) in the inner window sill with a screw (TYPE B), as shown Fig. 32.

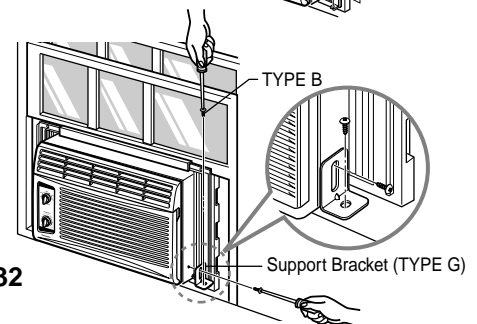
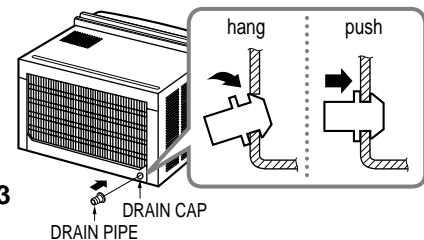

**Figure 32**

**7. Window installation of room air conditioner is now completed. See ELECTRICAL DATA for attaching power cord to electrical outlet.**

**3.2.4 How to Secure the Drain pipe**

In humid weather, excess water may cause the BASE PAN to overflow. To drain the water, remove the DRAIN CAP and secure the DRAIN PIPE to the rear hole of the BASE PAN. (Fig. 33) Press the drain pipe into the hole by pushing down and away from the fins to avoid injury.

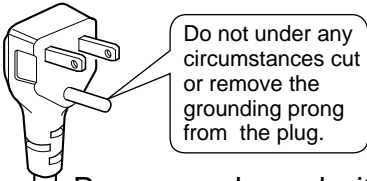
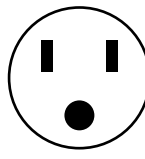

**Figure 33**

## REMOVAL FROM WINDOW

Turn the air conditioner off, disconnect the power cord, remove the Support Bracket, L bracket and the screws installed through the top and bottom of the guide panels, and save for reinstallation later. Close the guide panels. Keeping a firm grip on the air conditioner, raise the sash, and carefully tilt the air conditioner backward, draining any condensate. Lift the air conditioner from the window and remove the sash seal from between the windows.

## 3.3 ELECTRICAL DATA

Line Cord Plug	Use Wall Receptacle	Power Supply
 <p>Power supply cord with 3-prong grounding plug</p>	 <p>Standard 125V, 3-wire grounding receptacle rated 15A, 125V AC</p>	<p>Use 15 AMP, time delay fuse, or circuit breaker.</p>

## USE OF EXTENSION CORDS

Because of potential safety hazards, we strongly discourage the use of an extension cord. However, if you wish to use an extension cord, use a CSA certified/UL-listed 3-wire (grounding) extension cord, rated 15A, 125V.

## 4. TROUBLESHOOTING GUIDE

### 4.1 OUTSIDE DIMENSIONS (unit: mm [in])

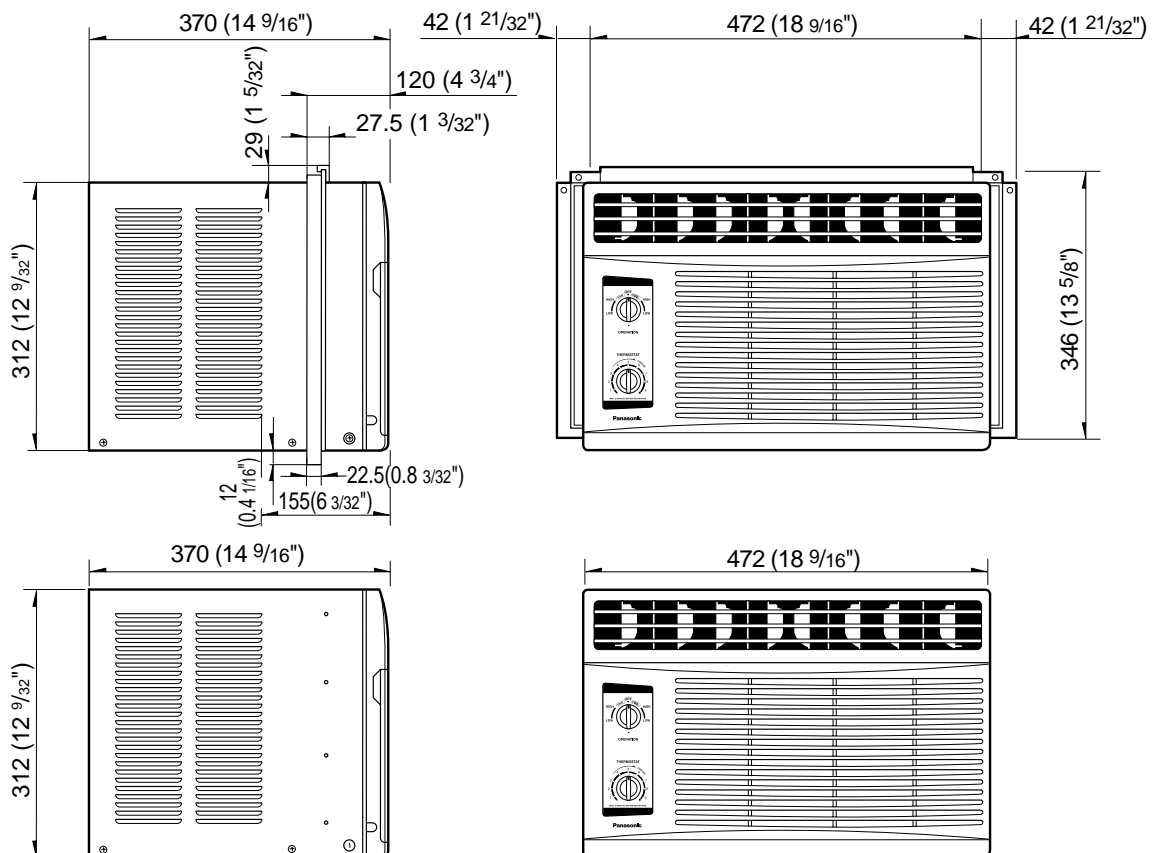

## 4.2 PIPING SYSTEM

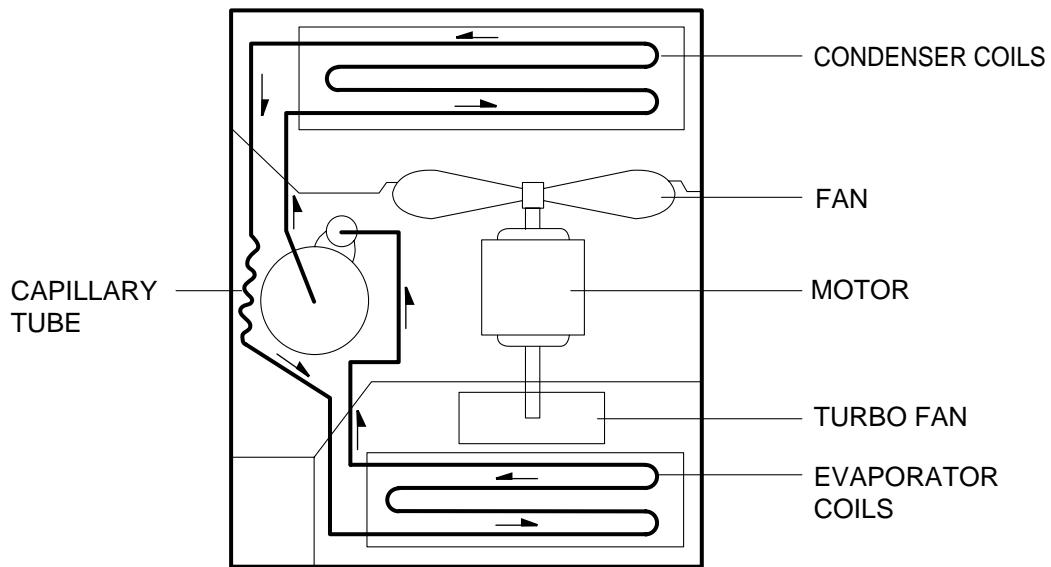

Following is a brief description of the important components and their function in what is called the refrigeration system. Reference should be made to Figure 34 to follow the refrigerating cycle and the flow of the refrigerant in the cooling cycle.

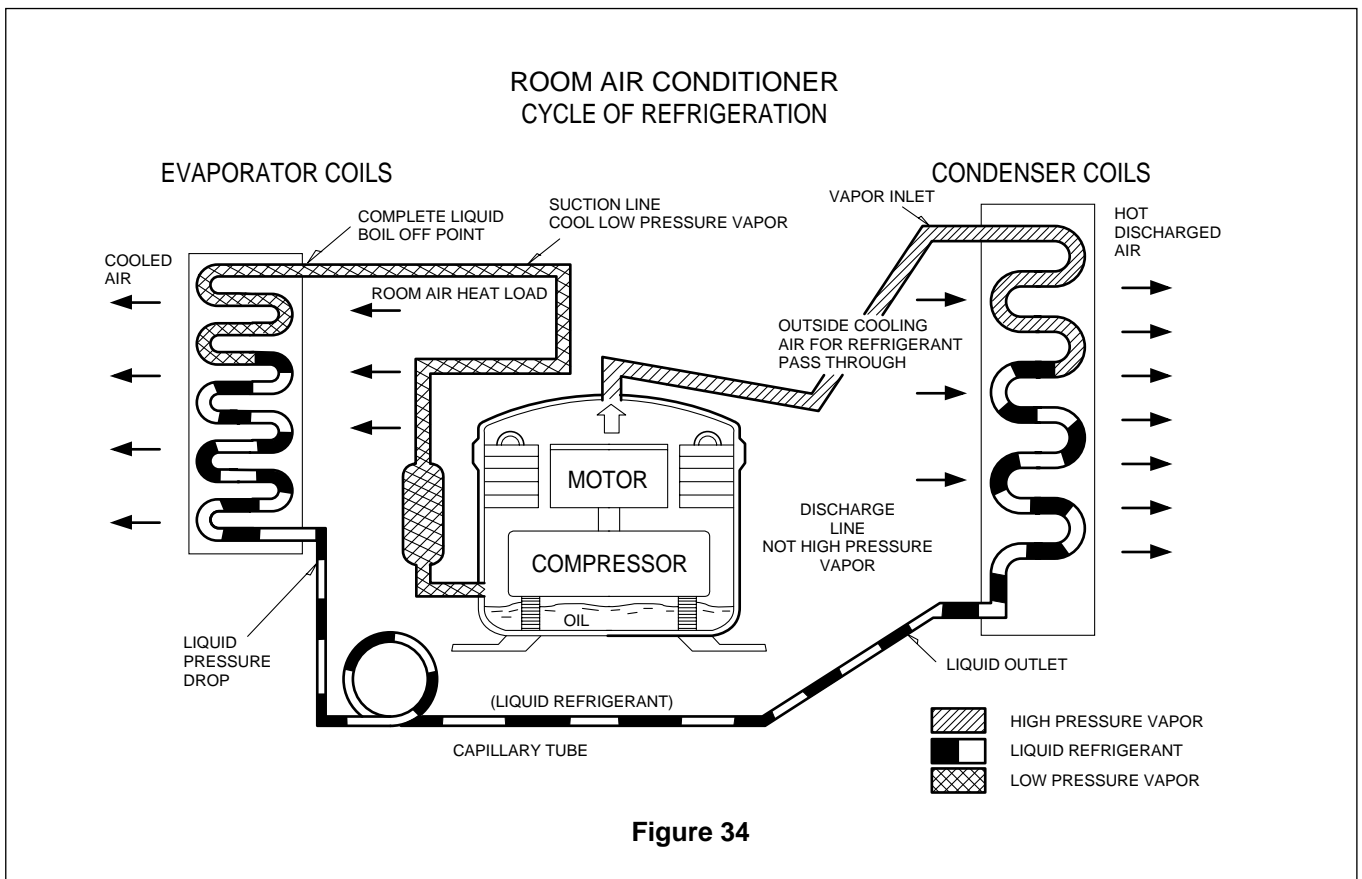

### 4.3 TROUBLESHOOTING GUIDE

In general, possible trouble is classified in two kinds.

The one is called **Starting Failure** which is caused by an electrical defect. The other is **Ineffective Air Conditioning** caused by a defect in the refrigeration circuit and improper application.

#### Unit is running but cooling is ineffective.

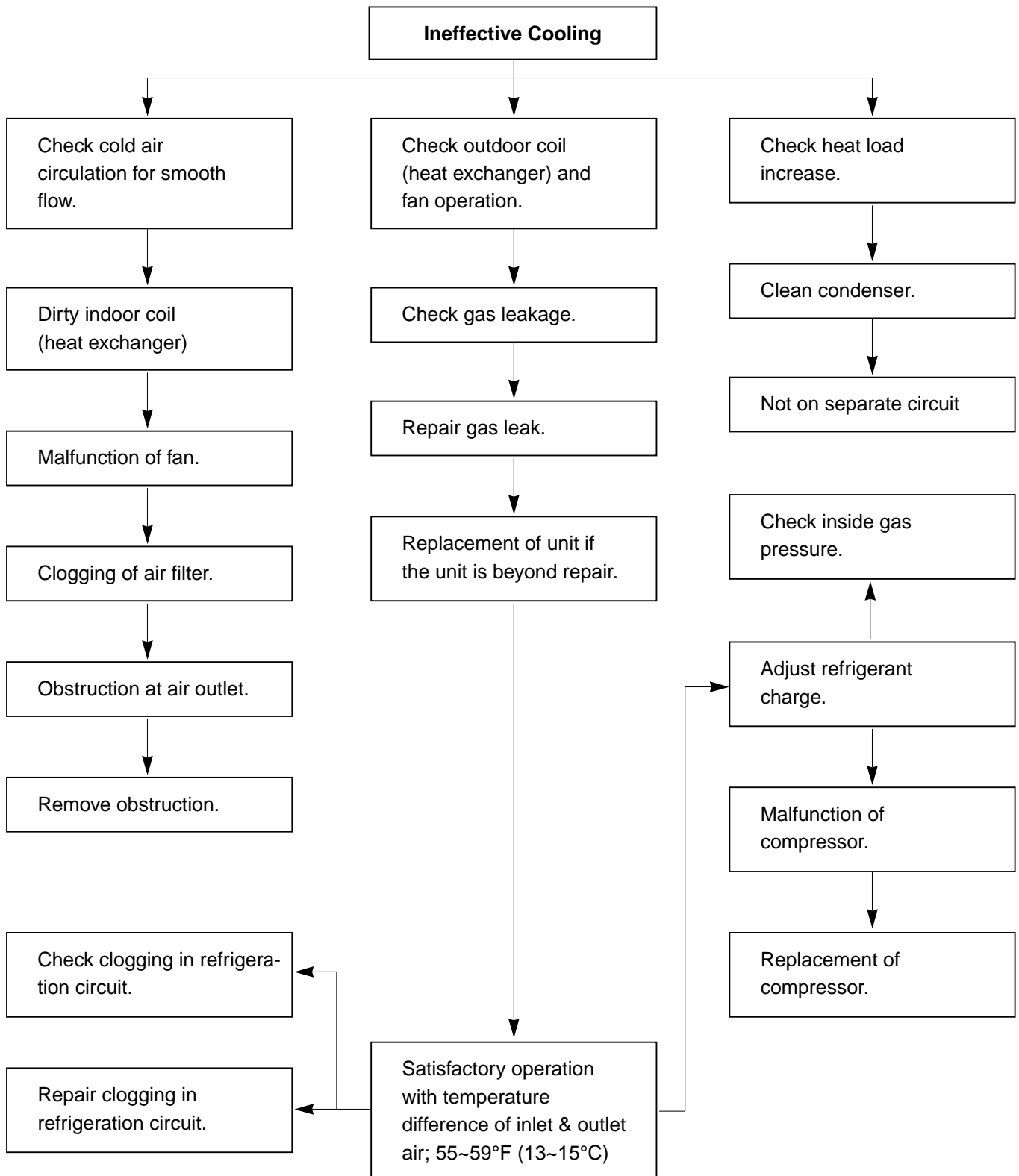

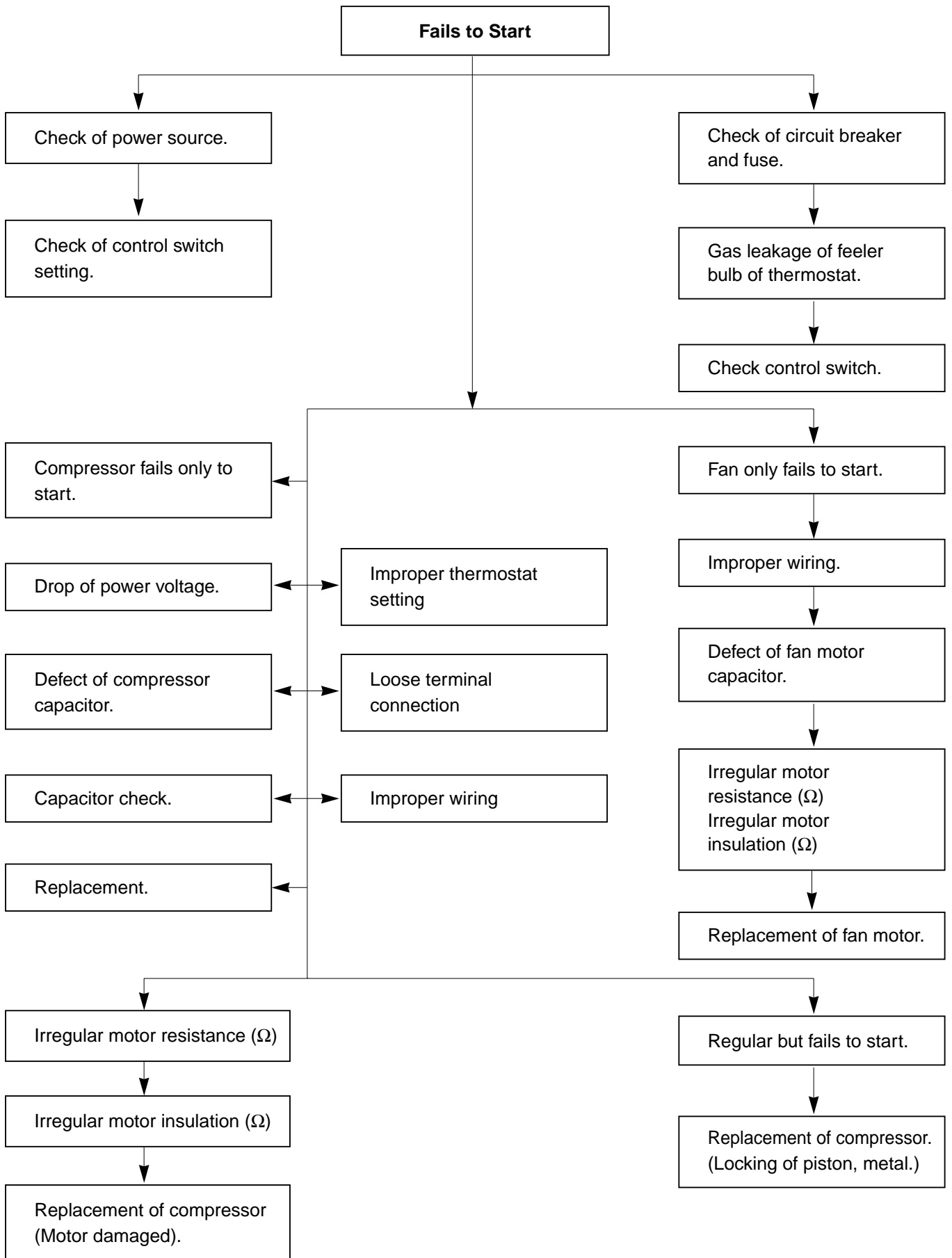

## ROOM AIR CONDITIONER VOLTAGE LIMITS

NAME PLATE RATING	MINIMUM	MAXIMUM
AC 115V $\pm$ 10%	AC 103.5V	AC 126.5V

COMPLAINT	CAUSE	REMEDY
Fan motor will not run.	No power	Check voltage at outlet. Correct if none.
	Power supply cord	Check voltage to rotary switch. If none, check power supply cord. Replace cord if circuit is open.
	Rotary switch	Check switch continuity. Refer to wiring diagram for terminal identification. Replace switch if defective.
	Wire disconnected or connection loose	Connect wire. Refer to wiring diagram for terminal identification. Repair or replace loose terminal.
	Capacitor (Discharge capacitor before testing.)	Test capacitor. Replace if not within $\pm$ 10% of manufacturer's rating. Replace if shorted, open, or damaged.
	Will not rotate	Fan blade hitting shroud or blower wheel hitting scroll. Re-align assembly.  Units using slinger ring condenser fans must have 5.6mm(7/32")~6.35mm(1/4") clearance to the base. If necessary, shim up the bottom of the fan motor with mounting screw(s).  Check fan motor bearings; if motor shaft will not rotate, replace the motor.
Fan motor runs.	Revolves on overload	Check voltage. See limits on this page.  If not within limits, call an electrician.  Test capacitor. Check bearings. Does the fan blade rotate freely? If not, replace fan motor.  Pay attention to any change from high speed to low speed. If the speed does not change, replace the motor.

COMPLAINT	CAUSE	REMEDY
Fan motor noise.	Fan	If cracked, out of balance, or partially missing, replace it.
	Blower	If cracked, out of balance, or partially missing, replace it.
	Loose set screw	Tighten it.
	Worn bearings	If knocking sounds continue when running or loose, replace the motor. If the motor hums or noise appears to be internal while running, replace motor.
Compressor will not run, fan motor runs.	Voltage	Check voltage. See the limits on the preceding page. If not within limits, call an electrician.
	Wiring	Check the wire connections; if loose, repair or replace the terminal. If the wires are disconnected, refer to wiring diagram for identification, and replace the wires. Check the wire connections; If not according to the wiring diagram, correct the connections.
	Rotary	Check for continuity, refer to the wiring diagram for terminal identification. Replace the switch if the circuit is open.
	Thermostat	Check the position of knob. If not at the coldest setting, advance the knob to this setting and restart the unit.
		Check the continuity of the thermostat. Replace the thermostat if the circuit is open.
	Capacitor (discharge capacitor before servicing.)	Check the capacitor. Replace if not within $\pm 10\%$ of manufacturer's rating, replace if shorted, open, or damaged.
	Compressor	Check the compressor for open circuit or ground. If open or grounded, replace the compressor.
	Overload	Check the compressor overload if externally mounted. Replace if open. (If the compressor temperature is high, remove the overload, cool, and retest.)
Compressor cycles on overload.	Voltage	Check the voltage. See the limits on the preceding page. If voltage is not within these limits, call an electrician.
	Overload	Check overload, if externally mounted. Replace if open. (If the compressor temperature is high, remove the overload, cool, and retest.)

<b>COMPLAINT</b>	<b>CAUSE</b>	<b>REMEDY</b>
Compressor cycles on overload.	Fan motor	If not running, determine the cause. Replace if required.
	Condenser air flow restriction	Remove the cabinet, inspect the interior surface of the condenser. If restricted, clean carefully with a vacuum cleaner (do not damage fins) or brush. Clean the interior base before re-assembling.
	Condenser fins (damaged)	If the condenser fins are closed over a large area on the coil surface, head pressures will increase, causing the compressor to cycle. Straighten the fins or replace the coil.
	Capacitor	Test the capacitor.
	Wiring	Check the terminals. If loose, repair or replace.
	Refrigeration system	Check the system for a restriction.
Insufficient cooling	Air filter	If restricted, clean or replace.
	Unit undersized	Determine if the unit is properly sized for the area to be cooled.
Excessive noise	Blower or fan	Check the set screw, or clamp. If loose or missing, correct. If the blower or fan is hitting scroll or barrier, rearrange the air handling parts.
	Copper tubing	Remove the cabinet and carefully rearrange the tubing not to contact the cabinet, compressor, shroud, and barrier.

# 5. CIRCUIT DIAGRAM

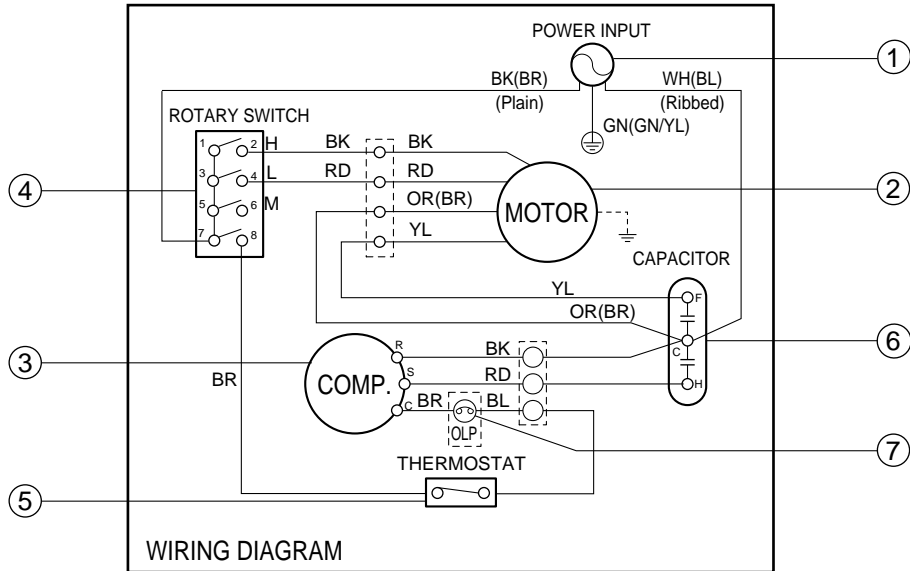

REF. NO	DESCRIPTION & NAME	Q'TY	CW-C53GK	CW-C53HU	REMARKS
1	POWER CORD ASSY	1	CWL00002	CWL00002	R
2	FAN MOTOR	1	CW468110002P	CW468110002Q	R
3	COMPRESSOR	1	CW2520ABC2JA	CW541620004D	R
4	ROTARY SWITCH	1	CWL00004	CWL00004	R
5	THERMOSTAT	1	CWL00003	CWL00003	R
6	CAPACITOR	1	CWL00005	CWL00005	R
7	OVERLOAD PROTECTOR	1	CWL00013	CW675030001U	R

NOTE: "R" mark is recommendable parts.

# 6. EXPLODED VIEW

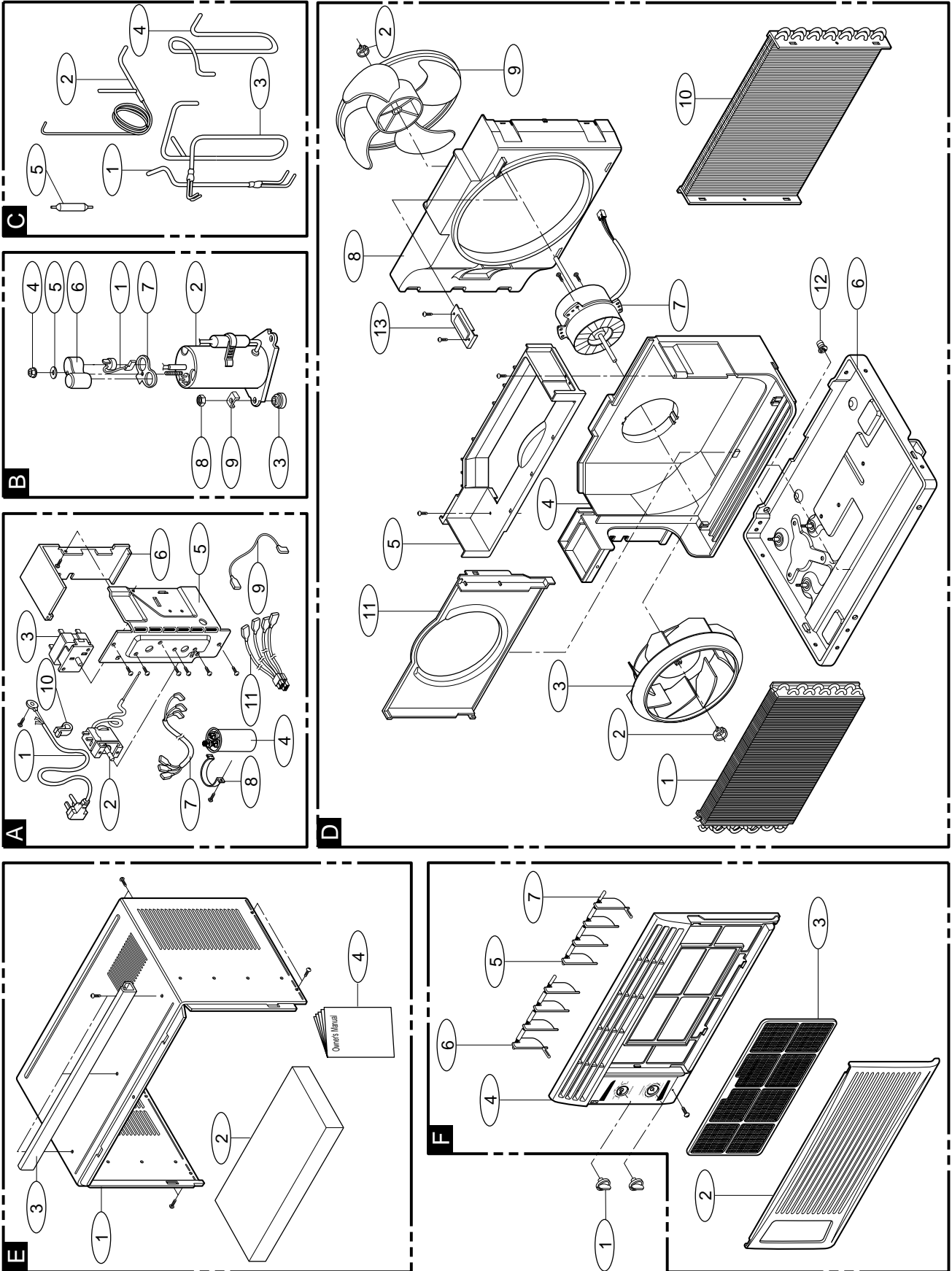

# 7. SERVICE PARTS LIST

R: RECOMMANDABLE PARTS

REF. NO	DESCRIPTION & NAME	Q'TY	CW-C53GK	CW-C53HU	REMARKS
A	CONTROL BOX ASSEMBLY	1	CWL00001	CWL00001	
A-1	POWER CORD ASSEMBLY	1	CWL00002	CWL00002	R
A-2	THERMOSTAT ASSEMBLY	1	CWL00003	CWL00003	R
A-3	SWITCH,ROTARY	1	CWL00004	CWL00004	R
A-4	CAPACITOR	1	CWL00005	CWL00005	R
A-5	CONTROL BOX	1	CWL00006	CWL00006	
A-6	COVER	1	CWL00007	CWL00007	
A-7	CONDUCTOR ASSEMBLY	1	CWL00008	CWL00008	
A-8	CLAMP FOR CAPACITOR	1	CWL00009	CWL00009	
A-9	CONDUCTOR ASSEMBLY	1	CWL00010	CWL00010	
A-10	CLIP	1	CWL00011	CWL00011	
A-11	LEAD WIRE ASSEMBLY	1	CWL00012	CWL00012	
B-1	OVERLOAD PROTECTOR	1	CWL00013	CW675030001U	R
B-2	COMPRESSOR	1	CW2520ABC2JA	CW541620014D	R
B-3	RUBBER,MOUNTING	3	CWL00015	CWL00015	
B-4	NUT,TERMINAL COVER	1	CWL00016	CWL00016	
B-5	GASKET-NUT	1	CWL00017	CWL00017	
B-6	COVER	1	CWL00018	CW355030048A	
B-7	GASKET	1	CWL00019	CW498630001A	
B-8	HEXAGON NUT	3	CWL00020	CWL00020	
B-9	BRACKET,WASHER	3	CWL00021	CWL00021	
C-1	TUBE ASSEMBLY,EVAPORATOR IN	1	CW521110063A	CW521110063C	
C-2	TUBE ASSEMBLY,CAPILLARY	1	CW521030018J	CW521030018K	
C-3	TUBE ASSEMBLY,SUCTION	1	CW521110062A	CW521110062B	
C-4	TUBE ASSEMBLY,DISCHARGE	1	CWL00025	CWL00025	
C-5	DRIER ASSEMBLY	1	CW585130001L	CW585130001L	
D-1	EVAPORATOR ASSEMBLY	1	CWL00026	CW542120016G	
D-2	CLAMP SPRING	2	CWL00027	CWL00027	
D-3	FAN,TURBO	1	CWL00028	CW590010005A	R
D-4	AIR GUIDE	1	CWL00029	CWL00029	
D-5	AIR GUIDE	1	CWL00030	CW523910005B	
D-6	BASE ASSEMBLY	1	CWL00031	CWL00031	

## R: RECOMMANDABLE PARTS

REF. NO	DESCRIPTION & NAME	Q'TY	CW-C53GK	CW-C53HU	REMARKS
D-7	MOTOR ASSEMBLY	1	CW468110012P	CW468110002Q	R
D-8	SHROUD	1	CWL00033	CWL00033	
D-9	FAN,PROPELLER	1	CWL00034	CWL00034	R
D-10	CONDENSER ASSEMBLY	1	CW5403R6200C	CW540320009E	
D-11	ORFICE	1	CWL00036	CWL00036	
D-12	DRAIN PIPE	1	CWL00037	CWL00037	
D-13	BRACE	1	CWL00071	CWL00071	
E-1	CABINET	1	CWL00038	CWL00038	
E-2	INSTALLATION KIT	1	CWL00039	CWL00039	R
E-3	GUIDE	1	CWL00040	CWL00040	
E-4	OPERATING INSTRUCTION	1	CW382820046B	CW382820046B	
F	FRONT GRILLE ASSEMBLY	1	CW353110182A	CW353110182A	R
F-1	KNOB ASSEMBLY	2	CW494120002A	CW494120002A	R
F-2	GRILLE,INLET	1	CW353010133A	CW353010133A	
F-3	AIR FILTER	1	CW5231R2148H	CW5231R2148H	
F-4	GRILE,FRONT	1	CW353010132A	CW353010132A	
F-5	VANE	6	CWL00047	CWL00047	
F-6	VANE	2	CWL00048	CWL00048	
F-7	LINK	2	CWL00049	CWL00049	





