

***Friedrich***

# Room Air Conditioner Service and Parts Manual

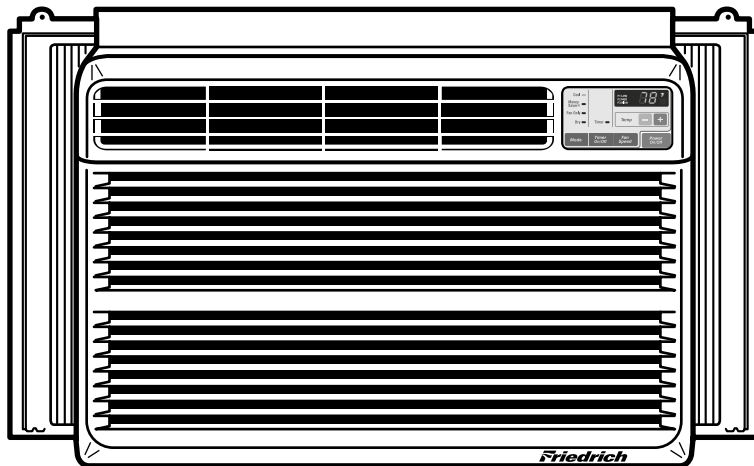

115Volts • ZQ08C10 • ZQ10C10 • CP08C10 • CP10C10 • CP12C10

# CONTENTS

## 1. PREFACE

1.1 SAFETY PRECAUTIONS.....	2
1.2 INSULATION RESISTANCE TEST.....	2
1.3 SPECIFICATIONS.....	3
1.4 FEATURES.....	4
1.5 CONTROL LOCATIONS .....	4

## 2. DISASSEMBLY INSTRUCTIONS

2.1 MECHANICAL PARTS .....	6
2.1.1 FRONT GRILLE .....	6
2.1.2 CABINET .....	6
2.1.3 CONTROL BOX .....	6
2.2 AIR HANDLING PARTS .....	7
2.2.1 AIR GUIDE AND TURBO FAN.....	7
2.2.2 FAN .....	7
2.2.3 SHROUD .....	8
2.3 ELECTRICAL PARTS.....	8
2.3.1 OVERLOAD PROTECTOR .....	8
2.3.2 COMPRESSOR.....	8
2.3.3 CAPACITOR.....	9
2.3.4 POWER CORD .....	9
2.3.5 MOTOR .....	10
2.4 REFRIGERATION CYCLE .....	10
2.4.1 CONDENSER.....	10
2.4.2 EVAPORATOR.....	10
2.4.3 CAPILLARY TUBE .....	11

## 3. TROUBLESHOOTING GUIDE

3.1 PIPING SYSTEM.....	13
3.2 TROUBLESHOOTING GUIDE .....	14

## 4. SCHEMATIC DIAGRAM .....

18

## 5. EXPLODED VIEW .....

19

## 6. REPLACEMENT PARTS LIST .....

20

## 1. PREFACE

This SERVICE MANUAL provides various service information, including the mechanical and electrical parts etc. This room air conditioner was manufactured and assembled under a strict quality control system.

The refrigerant is charged at the factory. Be sure to read the safety precautions prior to servicing the unit.

### 1.1 SAFETY PRECAUTIONS

1. When servicing, turn the unit Off and unplug the power cord.
2. Observe the original lead dress.  
If a short circuit is found, replace all parts which have been overheated or damaged by the short circuit.
3. After servicing, make an insulation resistance test to prevent the customer from being exposed to shock hazards.

### 1.2 INSULATION RESISTANCE TEST

1. Unplug the power cord and connect a jumper between 2 pins (black and white).
2. The grounding conductor (green or green and yellow) is to be open.
3. Measure the resistance value with an ohm meter between the jumpered lead and each exposed metallic part on the equipment at each working status.
4. The value should be over 1 MΩ.

## 1.3 SPECIFICATIONS

### 1.3.1 FOR ZQ08C10,ZQ10C10,CP08C10,CP10C10,CP12C10

ITEMS	MODELS					
	ZQ08C10	ZQ10C10	CP08C10	CP10C10	CP12C10	
POWER SUPPLY	1ø, 115V, 60HZ					
COOLING CAPACITY	(Btu/h)	7,800	9,800	7,800	10,000	11,800
INPUT	(W)	800	1,000	730	920	1,090
RUNNING CURRENT	(A)	7.6	9.4	6.6	8.5	10.1
E.E.R	(BTU/W.h)	9.7	9.8	10.8		
OPERATING CONDITION	INDOOR (iC)	26.7(DB)* 19.4(WB)**				
	OUTDOOR (iC)	35(DB)* 23.9(WB)**				
REFRIGERANT (R-22) CHARGE		300g(10.6oz)	520g(18.3oz)	420g(14.8oz)	525g(18.5oz)	510g(18.0oz)
EVAPORATOR		2 ROW 11STACKS	3 ROW 11STACKS		2 ROW 10STACKS	3 ROW 12STACKS
CONDENSER		2 ROW 16STACKS	2 ROW 16STACKS(L)		2 ROW 17STACKS	2 ROW 17STACKS(L)
FAN, INDOOR	TURBO FAN					
FAN, OUTDOOR	PROPELLER TYPE FAN WITH SLINGER RING					
FAN SPEEDS, FAN/COOLING		2/3		3/3		
FAN MOTOR	6 POLES					
OPERATION CONTROL		ROTARY SWITCH		REMOTE CONTROLLER		
ROOM TEMP. CONTROL		THERMOSTAT		THERMISTOR		
AIR DIRECTION CONTROL	VERTICAL LOUVER (RIGHT & LEFT)					
	HORIZONTAL LOUVER (UP & DOWN)					
CONSTRUCTION	SLIDE IN-OUT CHASSIS					
PROTECTOR	COMPRESSOR	OVERLOAD PROTECTOR				
	FAN MOTOR	INTERNAL THERMAL PROTECTOR				
POWER CORD	(3 WIRE WITH GROUDING)					
	ATTACHMENT PLUG (CORD-CONNECTED TYPE)					
DRAIN SYSTEM	DRAIN PIPE OR SPLASHED BY FAN SLINGER					
NET WEIGHT	(lbs/kg)	62/28				
OUTSIDE DIMENSION (W x H x D)	(inch)	20 <sup>3</sup> / <sub>32</sub> X 13 <sup>29</sup> / <sub>32</sub> X 19 <sup>3</sup> / <sub>8</sub>				
	(mm)	510 x 354 x 490				

\* DB: Dry Bulb

\*\*WB: Wet Bulb

## 1.4 SPECIFICATIONS

14.1 FOR ZQ08N10,

ITEMS		MODELS	CP08N10
POWER SUPPLY			1ø, 115V, 60HZ
COOLING CAPACITY	(Btu/h)		7,800
INPUT	(W)		800
RUNNING CURRENT	(A)		7.4
E.E.R	(BTU/W.h)		9.7
OPERATING CONDITION	INDOOR (iC)		26.7(DB)* 19.4(WB)**
	OUTDOOR (iC)		35(DB)* 23.9(WB)**
REFRIGERANT (R-22) CHARGE			420g(14.8oz)
EVAPORATOR			3 ROW 11STACKS
CONDENSER			2 ROW 16STACKS(L)
FAN, INDOOR			TURBO FAN
FAN, OUTDOOR			PROPELLER TYPE FAN WITH SLINGER RING
FAN SPEEDS, FAN/COOLING			3/3
FAN MOTOR			6 POLES
OPERATION CONTROL			REMOTE CONTROLLER
ROOM TEMP. CONTROL			THERMISTOR
AIR DIRECTION CONTROL			VERTICAL LOUVER (RIGHT & LEFT)
			HORIZONTAL LOUVER (UP & DOWN)
CONSTRUCTION			SLIDE IN-OUT CHASSIS
PROTECTOR	COMPRESSOR		OVERLOAD PROTECTOR
	FAN MOTOR		INTERNAL THERMAL PROTECTOR
POWER CORD			(3 WIRE WITH GROUING)
			ATTACHMENT PLUG (CORD-CONNECTED TYPE)
DRAIN SYSTEM			DRAIN PIPE OR SPLASHED BY FAN SLINGER
NET WEIGHT	(lbs/kg)		62/28
OUTSIDE DIMENSION (W x H x D)	(inch)		20 <sup>3</sup> / <sub>32</sub> X 13 <sup>29</sup> / <sub>32</sub> X 19 <sup>3</sup> / <sub>8</sub>
	(mm)		510 x 354 x 490

\* DB: Dry Bulb

\*\*WB: Wet Bulb

## 1.4 FEATURES

- Designed for COOLING ONLY.
- Slide-out chassis for the simple installation and service.
- Low air-intake, top cooled-air discharge.

- adjustable thermostat
- Washable one-touch filter
- Compact size

## 1.5 CONTROL LOCATIONS

### • THERMOSTAT (Fig A)

Thermostat will control the temperature of the discharge air. For a cooler setting, turn clockwise, For a warmer setting, turn counter clockwise.

### CONTROLS -"ZQ"MODELS

### • OPERATION (Fig A)

OFF : Turns the air conditioner off.

MED FAN : Medium fan speed without cooling.

LOW FAN : Low fan speed without cooling.

HIGH COOL : Cooling with the high fan speed.

MED COOL : Cooling with the medium fan speed.

LOW COOL : Cooling with the low fan speed.

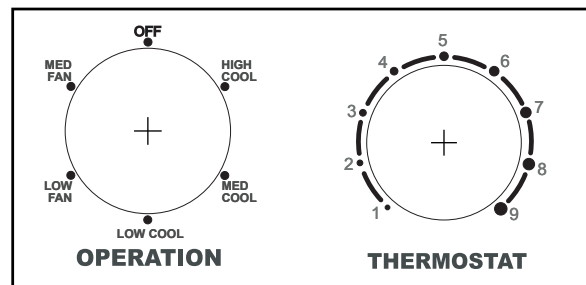

Fig A

## CONTROLS - "CP" MODELS

### DISPLAY

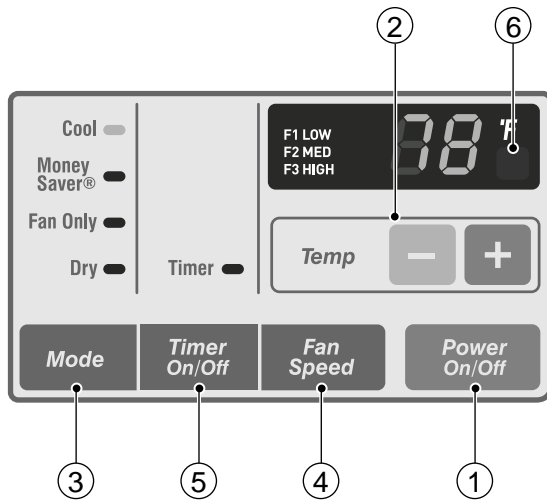

Fig B

### REMOTE CONTROL

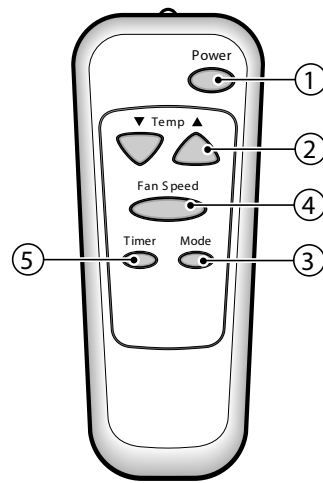

Fig C

**Precaution:** The Remote Control unit will not function properly if strong light shines on the sensor window of the air conditioner or if there are obstacles between the Remote Control unit and the air conditioner.

Refer to Fig B&Fig C

#### **1 POWER BUTTON**

To turn the air conditioner ON and OFF.  
This button takes priority over any other buttons.

#### **2 TEMPERATURE SETTING BUTTON**

This button can control temperature of the room. The temperature can be adjusted within a range of 60°F to 86°F by 1°F, Select the lower number for lower temperature of the room.

#### **3 OPERATION MODE SELECTION BUTTON**

Push this button, it will shift operation between COOL, ENERGY SAVER, FAN and DRY modes.

- Energy Saver: If Energy Save mode is selected, the fan stops when the compressor stops running  
Approximately every 3 minutes the fan will turn on and check the room air to determine if cooling is needed.

#### **4 FAN SPEED SELECTOR**

Push this button, to shift fan speeds, as follows.  
(Hi → Low → Med → Hi → Low →...)

#### **5 ON/OFF TIMER BUTTON**

ON - When the air conditioner is off, it can be set to automatically turn on.

OFF - When the air conditioner is on, it can be set to automatically turn off.

## 2. DISASSEMBLY INSTRUCTIONS

— Before servicing the unit, turn the unit OFF and disconnect the power cord.

### 2.1 MECHANICAL PARTS

#### 2.1.1 FRONT GRILLE

1. Open the Inlet grille downward and remove the air filter.
2. Remove the screw which fastens the front grille. (See Figure 1)
3. Pull the front grille from the right side.
4. Remove the front grille. (There are 4 hooks.)
5. Re-install the components by referring to the removal procedure, above.

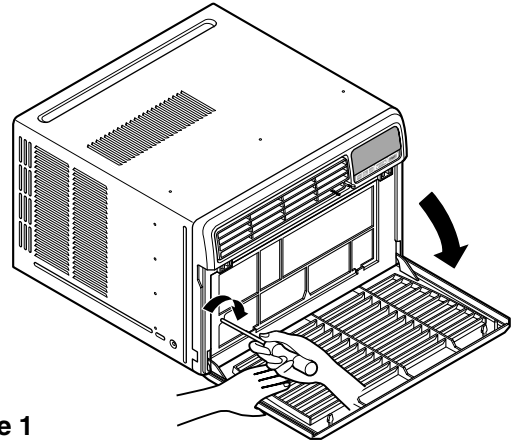

Figure 1

#### 2.1.2 CABINET

1. After removing the FRONT GRILLE, remove the 2 screws which fasten the cabinet at both sides.
2. Remove the 2 screws which fasten the cabinet at the back.
3. Pull the base pan forward. (See Figure 2)
4. Remove the cabinet.
5. Re-install the components by referring to the removal procedure, above.

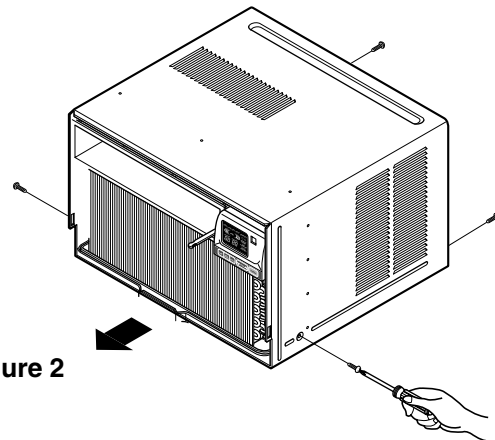

Figure 2

#### 2.1.3 CONTROL BOX

1. Remove the front grille. (Refer to section 2.1.1)
2. Remove the cabinet. (Refer to section 2.1.2)
3. Remove the 2 screws which fasten the power cord.
4. Disconnect the grounding screw from the evaporator channel.
5. Remove the 1 screw which fastens the control box cover.
6. Remove the housing which connects PCB (the control panel) (CP 08/10/12) or connector (ZQ 08/10) and motor wire in the control box.
7. Remove the nut which fastens the terminal cover.
8. Remove the terminal cover.
9. Remove all the leads from the overload protector.
10. Discharge the capacitor by placing a 20,000 ohm resistor across the capacitor terminals.
11. Raise the control box upward. (See Figure 3)
12. Re-install the components by referring to the removal procedure, above. (Refer to the circuit diagram found on page 19 in this manual and on the control box.)

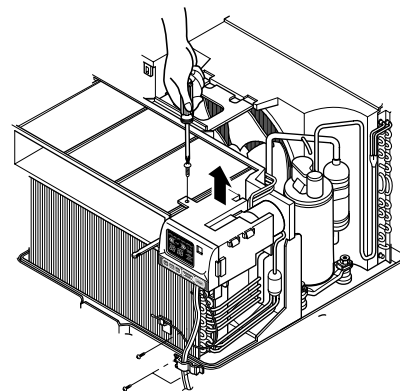

Figure 3

## 2.2 AIR HANDLING PARTS

### 2.2.1 AIR GUIDE AND TURBO FAN

1. Remove the front grille. (Refer to section 2.1.1)
2. Remove the cabinet. (Refer to section 2.1.2)
3. Remove the control box. (Refer to section 2.1.3)
4. Remove the 4 screws which fasten the brace.
5. Remove the brace.
6. Remove the 2 screws which fasten the discharge air guide.
7. Remove the air guide upper. (See figure 4)
8. Remove the 2 screws which fasten the evaporator.
9. Move the evaporator forward pulling it upward slightly. (See Figure 5)
10. Pull the hook out of orifice by pushing the tabs and remove it. (See Figure 6)
11. Using pliers remove the clamp which secures the turbo fan.
12. Remove the turbo fan.
13. Remove the 2 screws which fasten the air guide to the base pan.
14. Move the air guide backward, and pull out from the base pan. (Move the lower air guide carefully.)
15. Re-install the components by referring to the removal procedure, above.

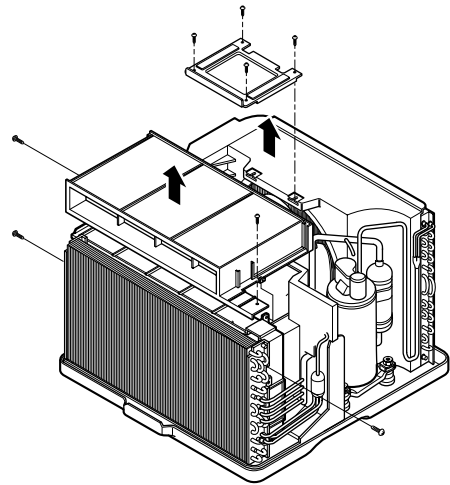

Figure 4

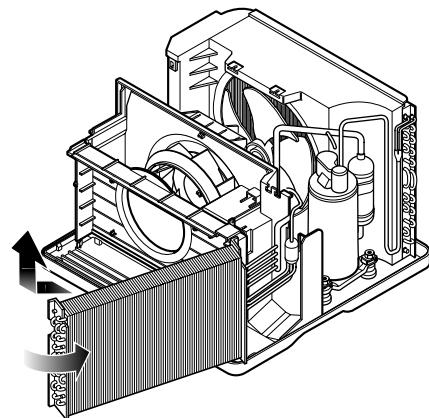

Figure 5

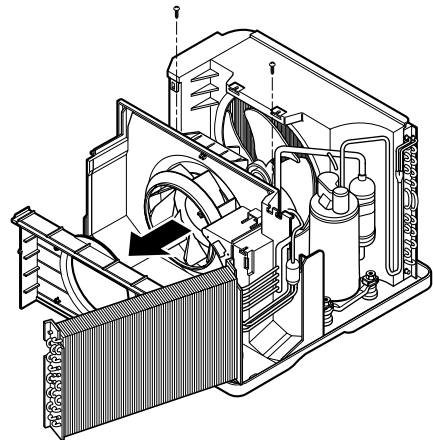

Figure 6

### 2.2.2 FAN

1. Remove the cabinet. (Refer to section 2.1.2)
2. Remove the brace (Refer to section 2.2.1)
3. Remove the 5 screws which fasten the condenser.
4. Move the condenser to the left carefully.
5. Remove the clamp which secures the fan.
6. Remove the fan. (See Figure 7)
7. Re-install by referring to the removal procedure.

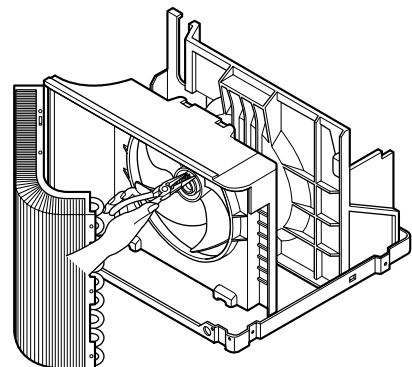

Figure 7



## 2.2.3 SHROUD

1. Remove the fan. (Refer to section 2.2.2)
2. Remove the shroud. (See Figure 8)
3. Re-install the components by referring to the removal procedure, above.

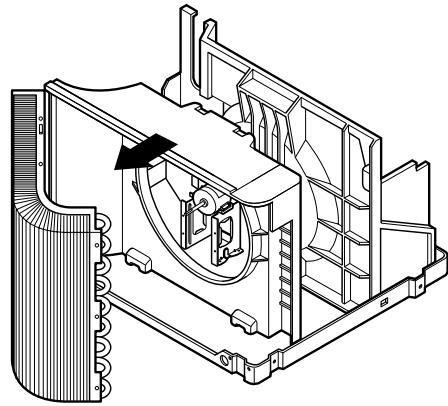

Figure 8

## 2.3 ELECTRICAL PARTS

### 2.3.1 OVERLOAD PROTECTOR

1. Remove the cabinet. (Refer to section 2.1.2)
2. Remove the nut which fastens the terminal cover.
3. Remove the terminal cover. (See Figure 9)
4. Remove all the leads from the overload protector.
5. Remove the overload protector.
6. Re-install the components by referring to the removal procedure, above.

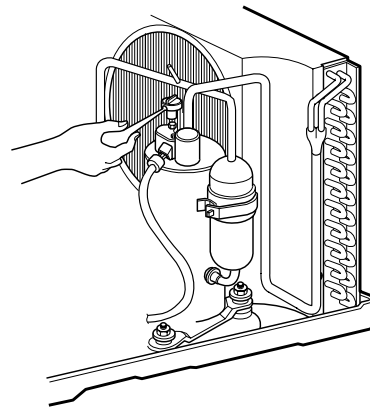

Figure 9

### 2.3.2 COMPRESSOR

1. Remove the cabinet. (Refer to section 2.1.2)
2. Discharge the refrigerant system using a Freon™ Recovery System.  
If there is no valve to attach the recovery system to, install one (such as a WATCO A-1) before venting the Freon™. Remove the valve when finished
3. Remove the overload protector. (Refer to section 2.3.1)
4. After purging the unit completely, unbraid the suction and discharge tubes at the compressor connections.
5. Remove the 3 nuts and the 3 washers which fasten the compressor.
6. Remove the compressor. (See Figure 10)
7. Re-install the components by referring to the removal procedure, above.

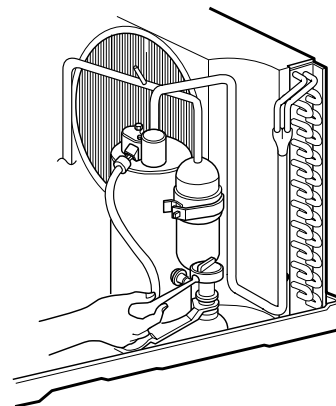

Figure 10

### 2.3.3 CAPACITOR

1. Remove the control box. (Refer to section 2.1.3)
2. Open the top cover from the control box.  
(See Figure 11)
3. Pull out the capacitor from the control box.
4. Disconnect all the leads of capacitor terminals.
5. Re-install the components by referring to the removal procedure, above.

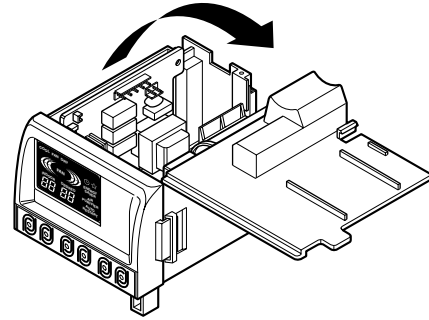

Figure 11

### 2.3.4 POWER CORD

1. Remove the control box. (Refer to section 2.1.3)
2. Open the top cover from the control box.  
(Refer to section 2.3.3)
3. Disconnect the front panel from the control box.  
(See Figure 12)
4. Disconnect the 2 receptacles and remove the grounding screw.
5. Pull out the power cord.
6. Re-install the component by referring to the removal procedure, above.  
(Use only one ground-marked hole for ground connection.)
7. If the supply cord of this appliance is damaged, it must be replaced by the factory supplied cord.

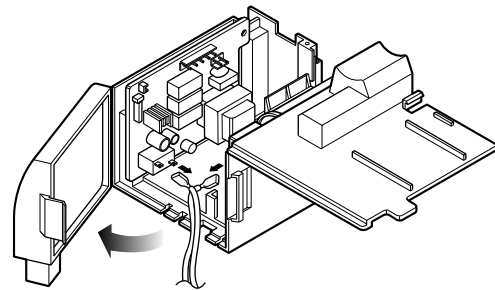
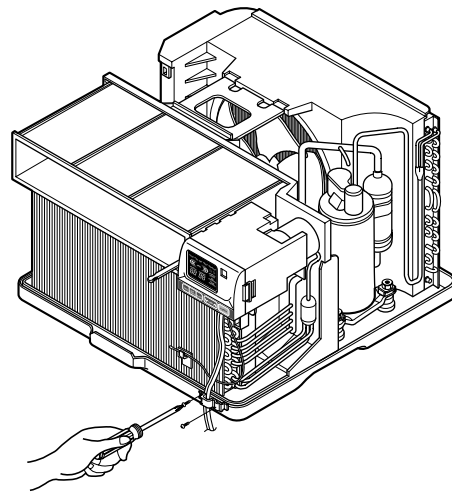

Figure 12

### 2.3.5 MOTOR

1. Remove the cabinet. (Refer to section 2.1.2)
2. Remove the turbo fan. (Refer to section 2.2.1)
3. Remove the fan. (Refer to section 2.2.2)
4. Remove the 4 screws which fasten the motor to the air guide. (See Figure 13)
5. Remove the motor.
6. Re-install the components by referring to the removal procedure, above.(See Figure 13)

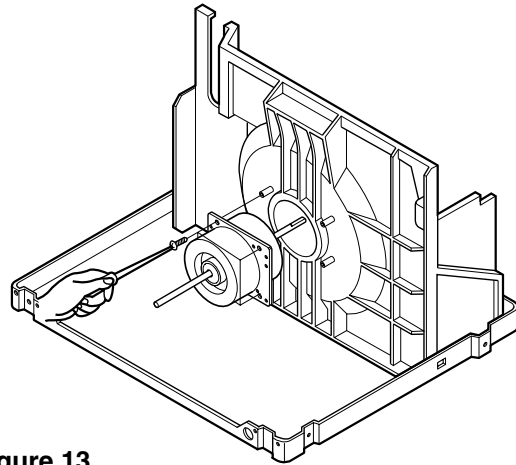

Figure 13

## 2.4 REFRIGERATION CYCLE

### 2.4.1 CONDENSER

#### CAUTION

Discharge the refrigerant system using a Freon™ Recovery System. If there is no valve to attach the recovery system, install one (such as a WATCO A-1) before venting the Freon™. Remove the valve when finished.

1. Remove the cabinet. (Refer to section 2.1.2)
2. Remove the 5 screws which fasten the brace.(Refer to section 2.2.1)
3. Remove the 5 screws which fasten the condenser and shroud.
4. After discharging the refrigerant completely, unbrazed the interconnecting tube at the condenser connections.
5. Remove the condenser.
6. Re-install the components by referring to notes. (See Figure 14)

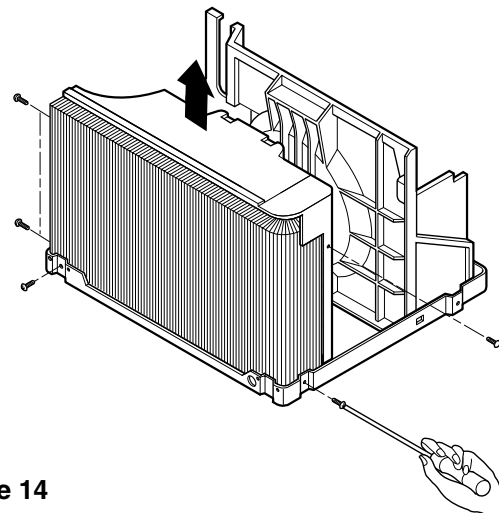

Figure 14

### 2.4.2 EVAPORATOR

1. Remove the control box.(Refer to section 2.1.3)
2. Remove the air guide upper. (Refer to section 2.2.1)
3. Remove the 2 screws which fasten the evaporator.
4. Move the evaporator sideways carefully. (Refer to section 2.2.1)
5. After discharging the refrigerant completely, unbrazed the interconnecting tube at the evaporator connections.
6. Remove the evaporator.
7. Re-install the components by referring to notes. (See Figure 15)

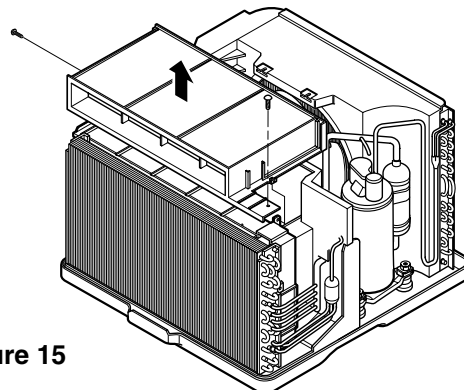

Figure 15

### 2.4.3 CAPILLARY TUBE

1. Remove the cabinet. (Refer to section 2.1.2)
2. After discharging the refrigerant completely, unbraid the interconnecting tube at the capillary tube. (See caution on previous page)
3. Remove the capillary tube.
4. Re-install the components by referring to notes.

#### NOTES

— Replacement of the refrigeration cycle.

1. When replacing the refrigeration cycle, be sure to Discharge the refrigerant system using a Freon™ recovery System.  
If there is no valve to attach the recovery system, install one (such as a WATCO A-1) before venting the Freon™. Remove the valve when finished.
  2. After discharging the unit completely, remove the desired component, and unbraid the pinch-off tubes.
  3. Solder service valves into the pinch-off tube ports, leaving the valves open.
  4. Evacuate as follows.
    - 1) Connect the vacuum pump, as illustrated figure 16A.
    - 2) Start the vacuum pump, slowly open manifold valves A and B with two full turns counterclockwise and leave the valves open. The vacuum pump is now pulling through valves A and B up to valve C by means of the manifold and entire system.
  5. Recharge as follows :
    - 1) Refrigeration cycle systems are charged from the High-side. If the total charge cannot be put in the High-side, the balance will be put in the suction line through the access valve which you installed as the system was opened.
    - 2) Connect the charging cylinder as shown in figure 16B.  
With valve C open, discharge the hose at the manifold connection.
    - 3) Open valve A and allow the proper charge to enter the system. Valve B is still closed.
    - 4) If more charge is required, the high-side will not take it. Close valve A.
    - 5) With the unit running, open valve B and add the balance of the charge.
      - a. Do not add the liquid refrigerant to the Low-side.
      - b. Watch the Low-side gauge; allow pressure to rise to 30 lbs.
      - c. Turn off valve B and allow pressure to drop.
      - d. Repeat steps b. and c. until the balance of the charge is in the system.
    - 6) When satisfied the unit is operating correctly, use the pinch-off tool with the unit still running and clamp on to the pinch-off tube. Using a tube cutter, cut the pinch-off tube about 2 inches from the pinch-off tool. Use sil-fos solder and solder pinch-off tube closed. Turn off the unit, allow it to set for a while, and then test for any leaks at the pinch-off connection.
- 3) Operate the vacuum pump for 20 to 30 minutes, until 600 microns of vacuum is obtained. Close valves A and B, and observe vacuum gauge for a few minutes. A rise in pressure would indicate a possible leak or moisture remaining in the system. With valves A and B closed, stop the vacuum pump.
  - 4) Remove the hose from the vacuum pump and place it on the charging cylinder. See figure 16B.  
Open valve C.  
Discharge the line at the manifold connection.
  - 5) The system is now ready for final charging.

#### CAUTION

If high vacuum equipment is used, just crack valves A and B for a few minutes, then open slowly with the two full turns counterclockwise. This will keep oil from foaming and being drawn into the vacuum pump.

**Equipment needed:** Vacuum pump, Charging cylinder, Manifold gauge, Brazing equipment, Pinch-off tool capable of making a vapor-proof seal, Leak detector, Tubing cutter, Hand Tools to remove components, Service valves.

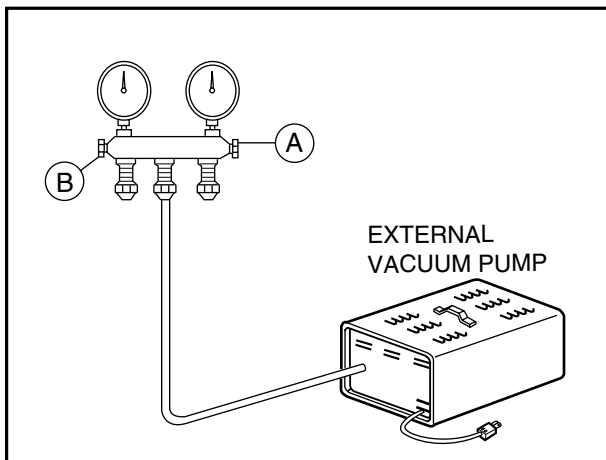
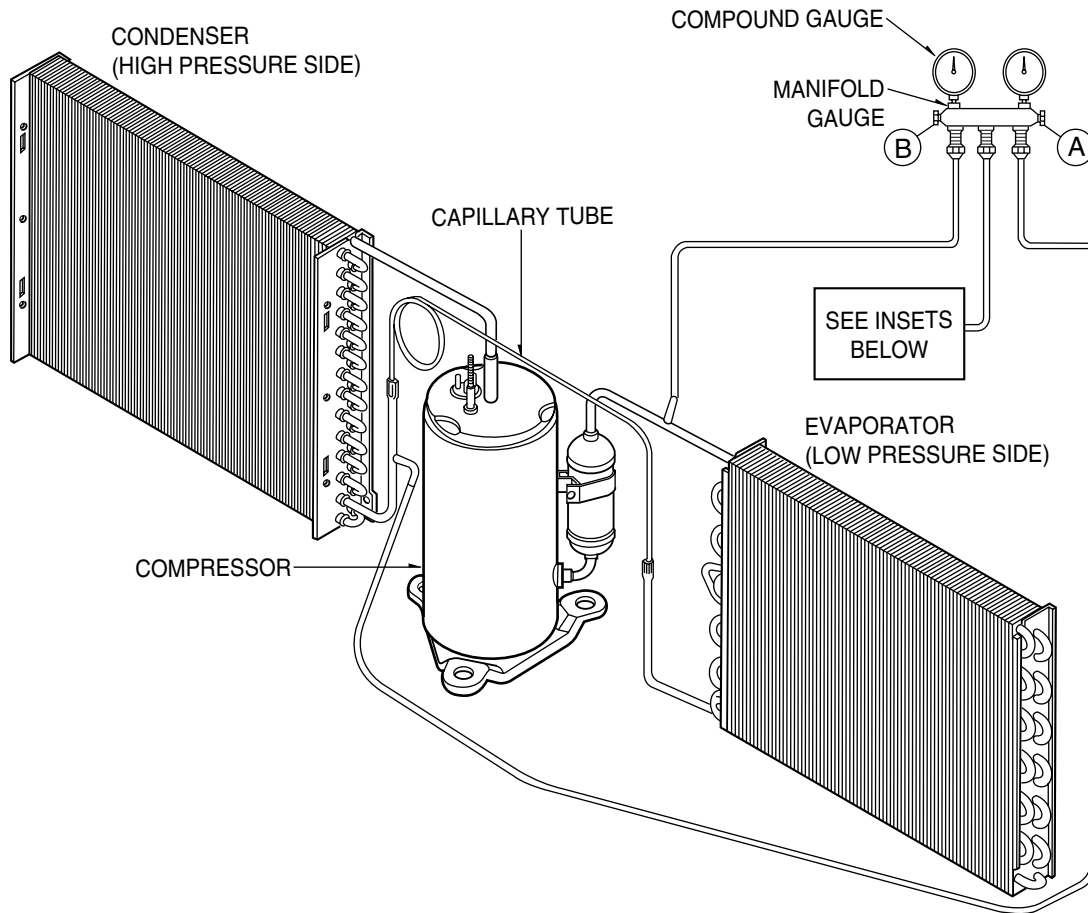

**Figure 16A-Pulling Vacuum**

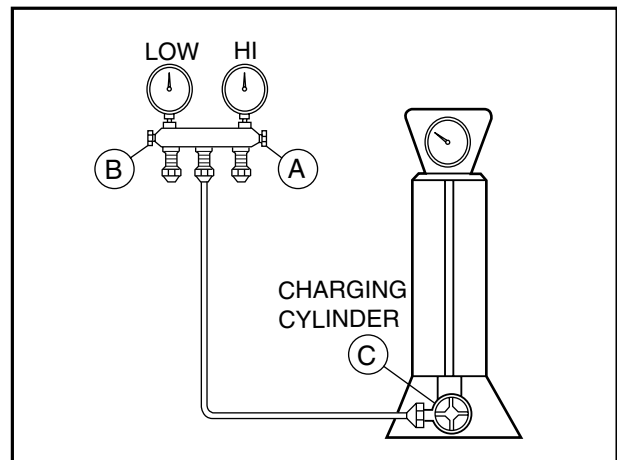

**Figure 16B-Charging**

# 3. TROUBLESHOOTING GUIDE

## 3.1 OUTSIDE DIMENSIONS

unit: mm(inch)

MODEL: ZQ08B10,CP08A10,ZQ10B10

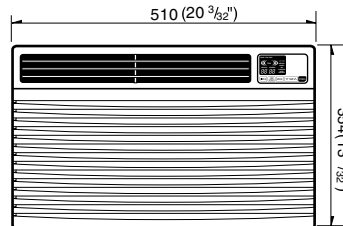
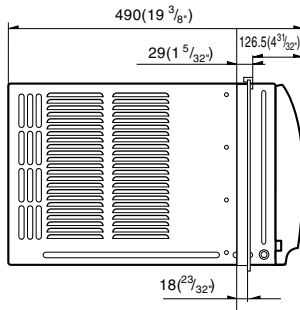

MODEL:CP10A10,CP12A10

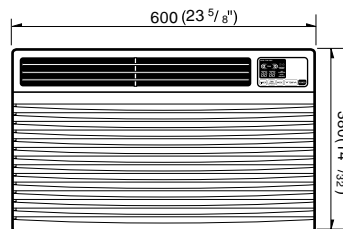
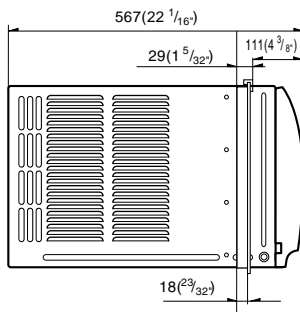

### 3.2 PIPING SYSTEM

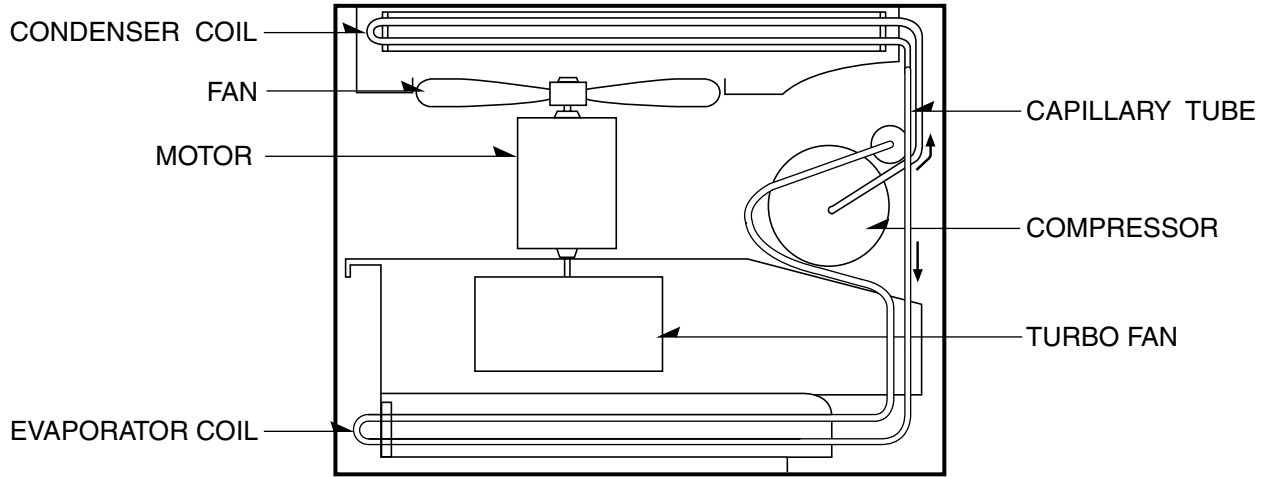
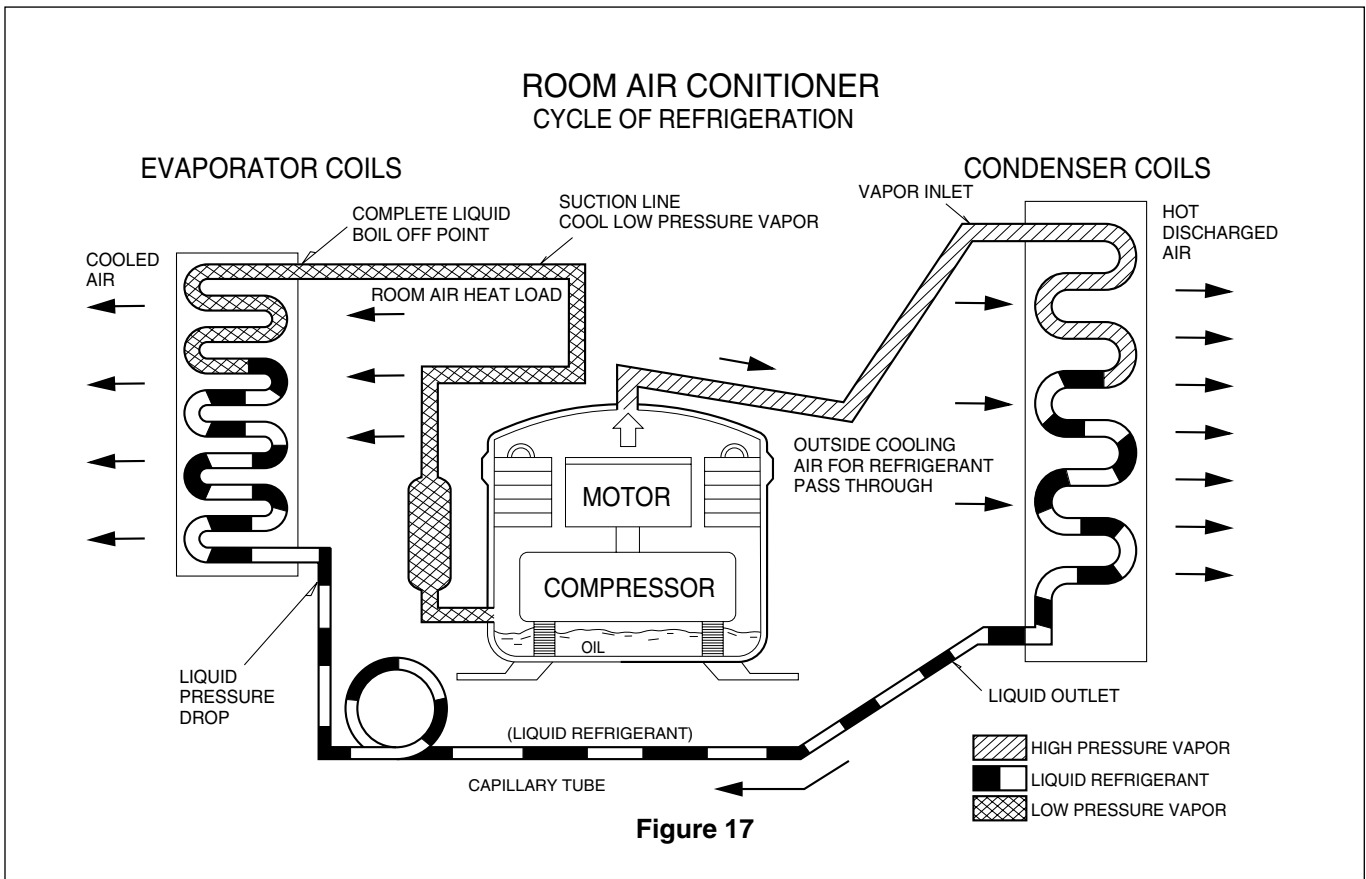
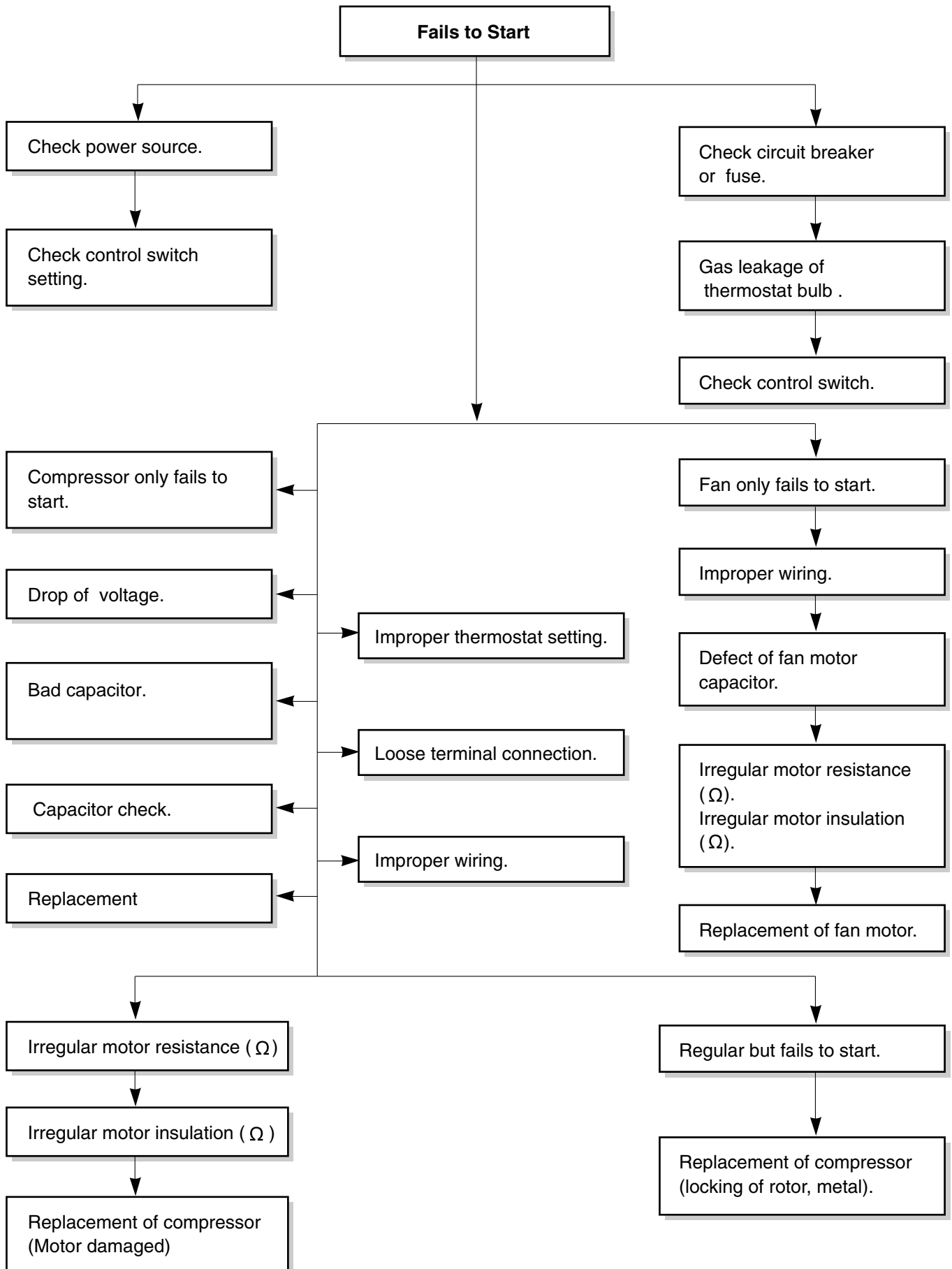

Figure 17 is a brief description of the important components and their function in what is called the refrigeration system. This will help you to understand the refrigeration cycle and the flow of the refrigerant in the cooling cycle.







COMPLAINT	CAUSE	REMEDY
Fan motor will not run.	No power	Check voltage at outlet. Correct if none.
	Power supply cord	Check voltage to rotary switch. If none, check power supply cord. Replace cord if circuit is open.
	Rotary switch	Check switch continuity. Refer to wiring diagram for terminal identification. Replace switch if defective.
	Wire disconnected or connection loose	Connect wire. Refer to wiring diagram for terminal identification. Repair or replace loose terminal.
	Capacitor (Discharge capacitor before testing.)	Test capacitor. Replace if not within $\pm 10\%$ of manufacturer's rating. Replace if shorted, open, or damaged.
	Will not rotate	Fan blade hitting shroud or blower wheel hitting scroll. Realign assembly.  Units using slinger ring for condenser fan must have $\frac{1}{4}$ to $\frac{5}{16}$ inch clearance to the base. If it hits the base, shim up the bottom of the fan motor with mounting screw(s).  Check fan motor bearings; if motor shaft will not rotate, replace the motor.
Fan motor runs intermittently	Revolves on overload.	Check voltage. If not within limits, call an electrician.  Test capacitor. Check bearings. Does the fan blade rotate freely? If not, replace fan motor.  Pay attention to any change from high speed to low speed. If the speed does not change, replace the motor.
Fan motor noise.	Fan	If cracked, out of balance, or partially missing, replace it.
	Blower	If cracked, out of balance, or partially missing, replace it.
	Loose clamp	Tighten it.
	Worn bearings	If knocking sounds continue when running or loose, replace the motor. If the motor hums or noise appears to be internal while running, replace motor.
Compressor will not run, but fan motor runs.	Voltage	Check voltage. If not within limits, call an electrician.
	Wiring	Check the wire connections, if loose, repair or replace the terminal. If wires are off, refer to wiring diagram for identification, and replace. Check wire locations. If not per wiring diagram, correct.
	Rotary	Check for continuity, refer to the wiring diagram for terminal identification. Replace the switch if circuit is open.

<b>COMPLAINT</b>	<b>CAUSE</b>	<b>REMEDY</b>
Compressor will not run, but fan motor runs.	Thermostat	Check the position of knob. If not at the coldest setting, advance the knob to this setting and restart unit. Check continuity of the thermostat. Replace thermostat if circuit is open.
	Capacitor (Discharge capacitor before servicing.)	Check the capacitor. Replace if not within $\pm 10\%$ of manufacturers rating. Replace if shorted, open, or damaged.
	Compressor	Check the compressor for open circuit or ground. If open or grounded, replace the compressor.
	Overload	Check the compressor overload, if externally mounted. Replace if open. (If the compressor temperature is high, remove the overload, cool it, and retest.)
Compressor cycles on overload.	Voltage	Check the voltage. If not within limits, call an electrician.
	Overload	Check overload, if externally mounted. Replace if open. (If the compressor temperature is high, remove the overload, cool, and retest.)
Compressor cycles on overload.	Fan motor	If not running, determine the cause. Replace if required.
	Condenser air flow restriction	Remove the cabinet. inspect the interior surface of the condenser; if restricted, clean carefully with a vacuum cleaner (do not damage fins) or brush. Clean the interior base before reassembling.
	Condenser fins (damaged)	If condenser fins are closed over a large area on the coil surface, head pressures will increase, causing the compressor to overload. Comb the fins or replace the coil.
Compressor cycles on overload.	Capacitor	Test capacitor.
	Wiring	Check the terminals. If loose, repair or replace.
	Refrigerating system	Check the system for a restriction.
Insufficient cooling or heating	Air filter	If restricted, blow out system or replace component.
	Exhaust damper door	Close if open.
	Unit undersized	Determine if the unit is properly sized for the area to be cooled.
Excessive noise	Blower or fan	Check the set screw or clamp. If loose or missing, correct. If the blower or fan is hitting air guide, rearrange the air handling parts.
	Copper tubing	Remove the cabinet carefully and rearrange tubing not to contact cabinet, compressor, shroud, and barrier.

# 4. SCHEMATIC DIAGRAM

MODEL: CP08C10, CP10C10, CP12C10

MODEL: ZQ08C10,ZQ10C10

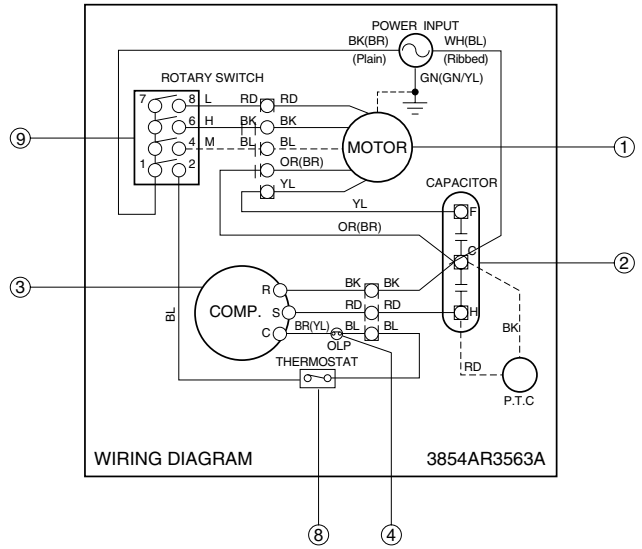
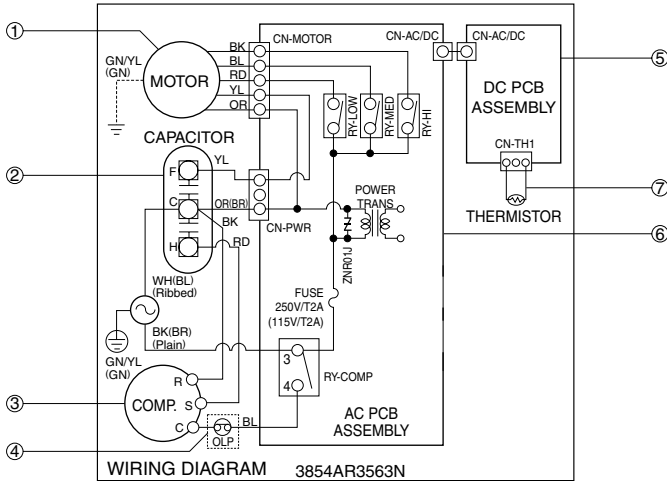

S: Service Parts  
N: Non Service Parts

LOCATION NO.	DESCRIPTION	Q'TY PER SET	RE-MARKS
1	MOTOR ASSY	1	S
2	CAPACITOR	1	S
3	COMPRESSOR	1	S
4	OVERLOAD PROTECTOR	1	S
5	DC PCB ASSEMBLY	1	S
6	AC PCB ASSEMBLY	1	S
7	THERMISTOR	1	S
8	THERMOSTAT	1	S
9	ROTARY SWITCH	1	S

# 5. EXPLODED VIEW

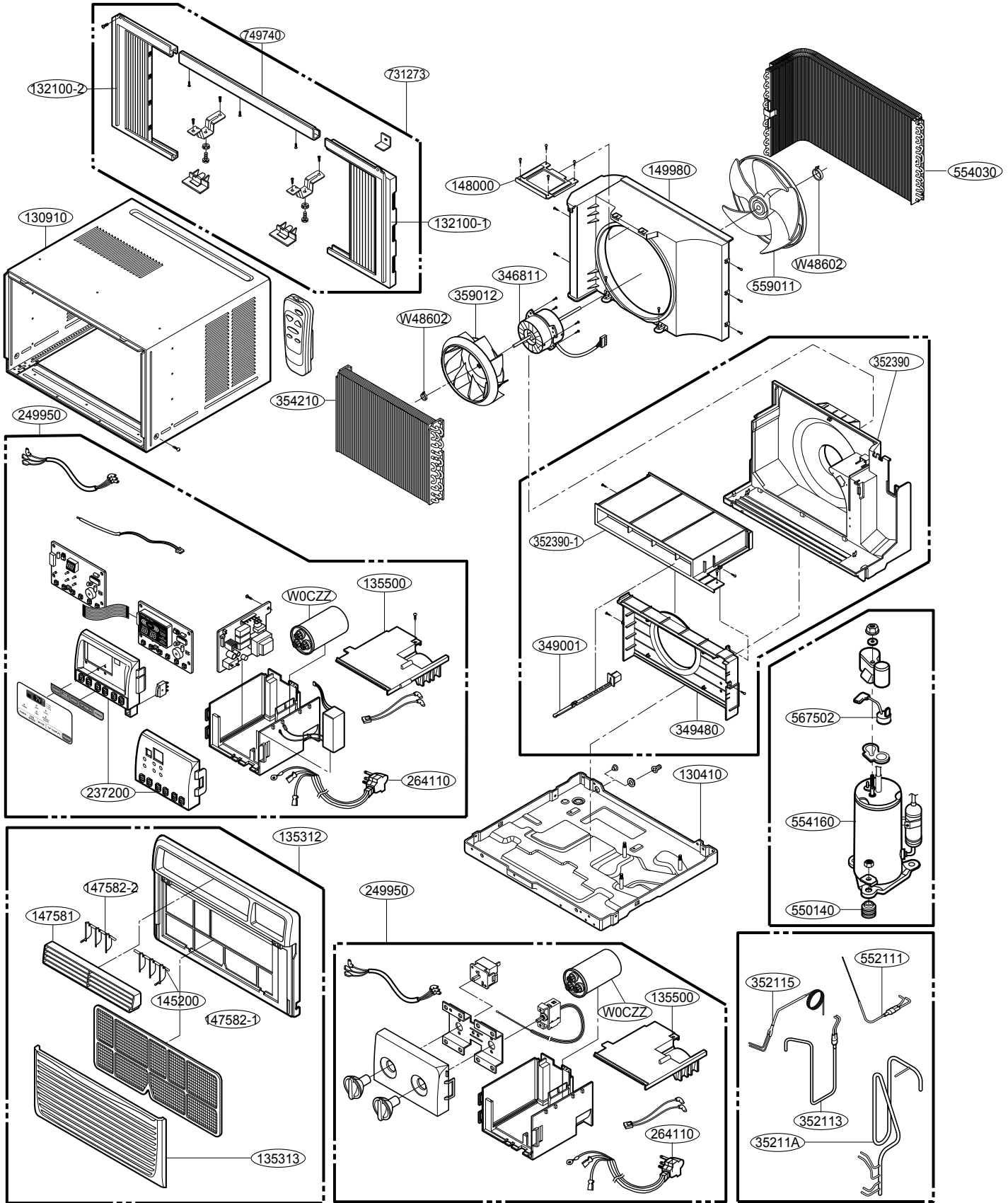

# 6. REPLACEMENT PARTS LIST

R: Service Parts  
N: Non Service Parts

•ZQ08C10 •ZQ10C10 •CP08C10 •CP12C10

LocNo	ZQ08C10	CP08C10	DESCRIPTION	REMARK
130410		67302924	Base Assy Single	R
130910		67303711	Cabinet Assy Single	R
135312		67306014	Grille Assy Front	R
135313		67306109	Grille Assy Inlet	R
135500		67300311	Cover	R
145200		67304601	Link	R
147582-1		67306260	Louver Vertical	R
147582-2		67306261	Louver Vertical	R
149410	67304105	---	Knob Assy	R
149980		67303114	Shroud	R
152302		67304306	Filter (Mech)	R
238310	---	67500116	Escutcheon	R
263230	---	67307807	Thermistor	R
269310	67300402	---	Thermostat	R
264110	67300021	67300021	Power Cord Assy	R
266003	67300501	---	Switch Rotary	R
267110	---	67307701	Remote Controller	R
268712	---	67307613	PWB(PCB) Assy Display	R
268714	---	67307614	PWB(PCB) Assy Main	R
346811	67303031	67303018	Motor Assy Single	R
349480		67303408	Orifice	R
352390-1		67302731	Air Guide Assy Upper	R
352390-2		67302718	Air Guide Assy Lower	R
550140		67301901	Isolator Comp	R
559011		67303201	Fan Blade	R
359012		67302611	Fan Turbo	R
567502	67301417	67301406	O.L.P.	R
W0CZZ	67300718	67300718	Capacitor	R
W48602		67302500	Clamp Spring	R
731373		67306309	Installation Kit w/Curtain	R
749740		67304007	Upper Guide Cabinet	R

LocNo	CP10C10	CP12C10	DESCRIPTION	REMARK
130410	3041A20020X	3041A20020J	Base Assy Single	R
130910	3091A10071G	3091A10071B	Cabinet Assy Single	R
135312	3531A20098F		Grille Assy Front	R
135313	3530A11006A		Grille Assy Inlet	R
135500	3550UTL006A		Cover	R
145200	4520A20007A		Link	R
147582-1	4758A20041A		Louver Vertical	R
147582-2	4758A20041B		Louver Vertical	R
149980	4998A10016A	4999A20001A	Shroud	R
152302	5231A20007A		Filter (Mech)	R
238310	3831A10021N		Escutcheon	R
263230	6323A20004P		Thermistor	R
264110	6411A20056E	6411A20056K	Power Cord Assy	R
267110	6711A20103P		Remote Controller	R
268714	6871A20418E		PWB(PCB) Assy Display	R
268712	6871A20617R		PWB(PCB) Assy Main	R
346811	4681A30025A	4681A20069K	Motor Assy Single	R
349480	4948A10015A		Orifice	R
35211A	5211A20441J	5211A20228E	Tube Assy Suction	R
352113	5211A10074S	5211A21901A	Tube Assy Discharge	R
352115	5421A20108C	5421A20099D	Tube Assy Evaporator In	R
352390-1	5239A20004A		Air Guide Assy Upper	R
352390-2	4974AR3262K		Air Guide Assy Lower	R
550140	-		Isolator Comp	R
552111	5211A32004B	5211AR3332W	Tube Assy Capillary	R
554160	2520UCBK023	2520UCBK027	Compressor	R
559011	5900A10009B		Fan Assy Axial	R
359012	5900A20019C		Fan Turbo	R
567502	6750UL031A	6750UL067A	O.L.P.	R
W0CZZ	0CF1042856A		Capacitor	R
W48602	3H02932B		Clamp Spring	R
132111-1	4959AR3402C		Installation Kit w/Curtains L	R
132111-2	4959AR3402D		Installation Kit w/Curtains R	R
749740	4974AR3262H		Upper Guide Cabinet	R

LOCATION NO.	DESCRIPTION	P/NO
		ZQ10C10
130410	Base Assembly, Single	3041A20021V
352390-1	Guide Assembly, Air	5239A20012A
359012	Fan, Turbo	5900A20020A
W48602	Clamp, Spring	3H02932B
349480	Orifice	4948A10014A
559011	Fan Assembly, Axial	5900AR1167B
352390-2	Guide Assembly, Air	5239A20005B
346811	Motor Assembly, AC	4681A20069N
149980	Shroud	4998A10023C
130910	Cabinet Assembly, Single	3091AR2317M
135312	Grille Assembly, Front	3531A20119B
135313	Grille, Inlet	3530A11005A
159830	Filter Assembly, Air Cleaner	5231A20006A
147582-1	Louver, Vertical	4758A20040A
147582-2	Louver, Vertical	4758A20040B
145200	Link	4520A20006A
749740	Guide	4974AR3328B
135500	Cover	3550A30194A
266003	Switch, Rotary	2H00598E
269310	Thermostat	2H01109L
W0CZZ	Capacitor, Film, Box	2H01451M
264110	Power Cord Assembly	6411A20056E
149410	Knob Assembly	4941A30022A
554160	Compressor Set, China	TBZ30826701
567502	Overload Protect	EAF36097201
550140	Damper, Compressor	4830AR4335B
35211A	Tube Assembly, Suction	5211A21786C
352115	Tube Assembly, Evaporator (In)	5211A20470L
352113	Tube Assembly, Discharge	5211A10074U
552111	Tube Assembly, Capillary	AJR32805501
132111-1	Curtain Assembly	4959AR3402A
132111-2	Curtain Assembly	4959AR3402B

LOCATION NO.	DESCRIPTION	P/NO
		CP08N10
130410	Base Assembly, Single	3041A20021V
352390-1	Guide Assembly, Air	5239A20012A
359012	Fan, Turbo	5900A20020A
W48602	Clamp, Spring	3H02932B
349480	Orifice	4948A10014A
559011	Fan Assembly, Axial	5900AR1167B
148000	Supporter	4800A30002C
352390-2	Guide Assembly, Air	5239A20005B
349001	Damper, Vent	4900A20003A
149980	Shroud	4998A10023C
346811	Motor Assembly, AC	4681A20069G
249950	Case Assembly, Control	4995A11014N
237200	Panel, Control	3720A10111C
268714	PCB Assembly, Main	6871A20617R
W0CZZ	Capacitor, Film, Box	0CF1042856A
268712	PCB Assembly, Display	6871A20418E
266003	Switch, Tact	6600R000017
264110	Power Cord Assembly	6411A20056A
263230	Thermistor, NTC	6323A20004P
130910	Cabinet Assembly, Single	3091AR2317M
135312	Grille Assembly, Front	3531A20119B
135313	Grille, Inlet	3530A11005A
159830	Filter Assembly, Air Cleaner	5231A20006A
147581	Louver, Horizontal	4758A20019A
147582-1	Louver, Vertical	4758A20040A
147582-2	Louver, Vertical	4758A20040B
145200	Link	4520A20006A
749740	Guide	4974AR3328B
731373	Install Part Assembly, Single	3127A10015B
132111-1	Curtain Assembly	4959AR3402A
132111-2	Curtain Assembly	4959AR3402B
267110	Remote Controller Assembly	6711A20103P
550140	Compressor Set, China	2520UCBA013
567502	Overload Protect	6750U3L018A
135500	Cover	3550UTL006A
554160	Damper, Compressor	4830AR4335A
354210	Evaporator Assembly, First	5421A10026M
35211A	Tube Assembly, Suction	5211A20228Z
352115	Tube Assembly, Evaporator (In)	5211A20559Q
554030	Condenser Assembly, First	5403A20092G
352113	Tube Assembly, Discharge	5211A20708G
552111	Tube Assembly, Capillary	5211A30275N



# MEMO

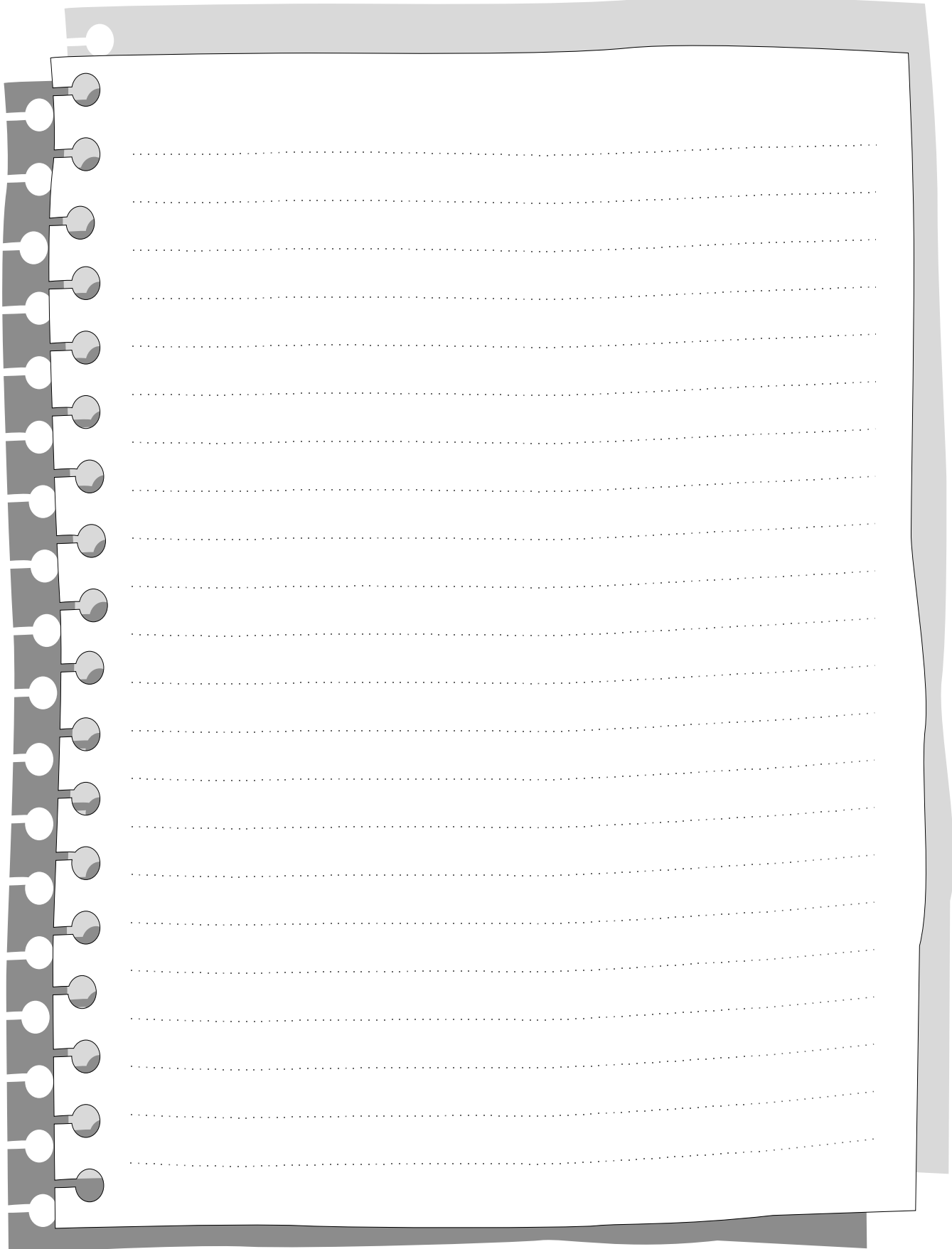

# MEMO

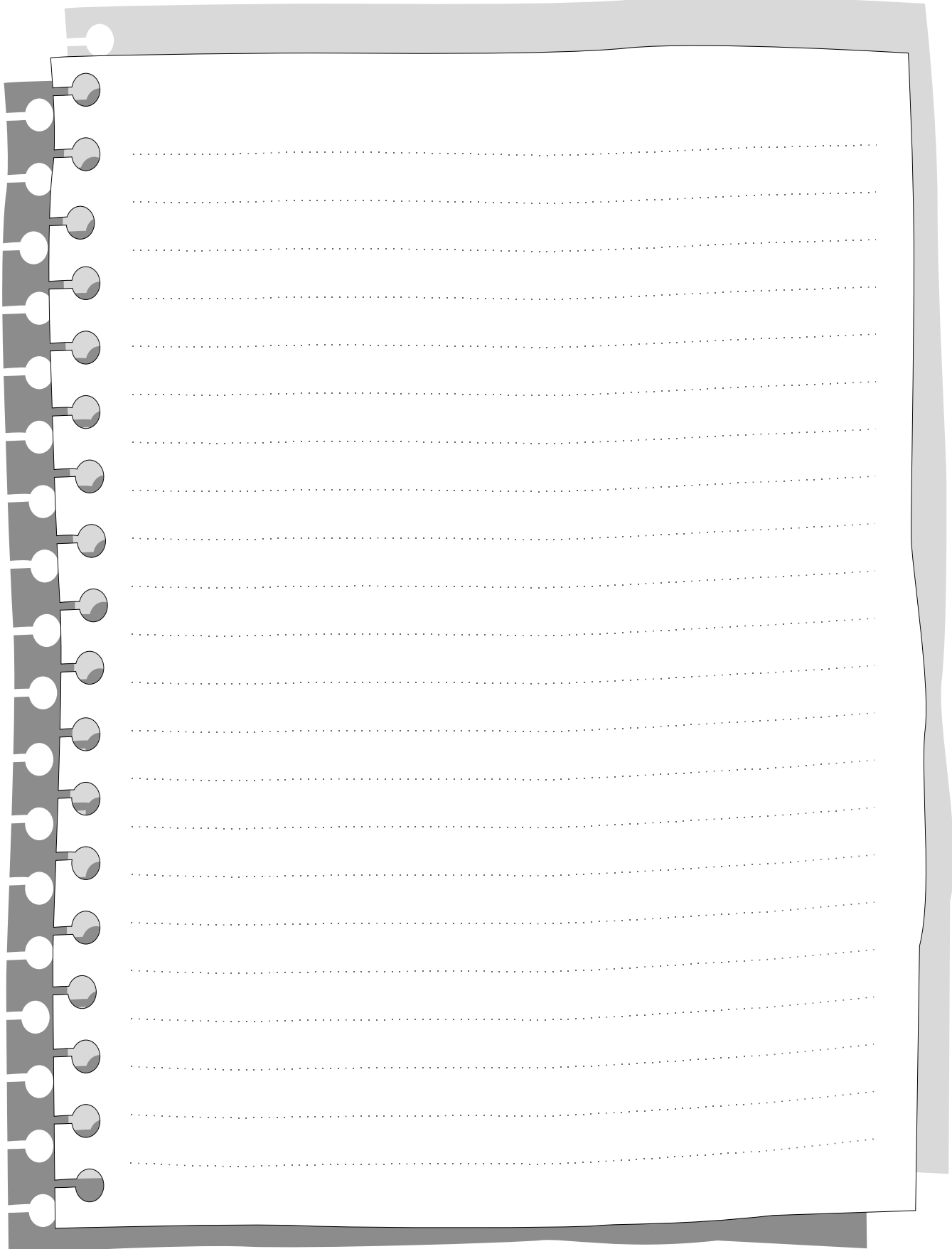

# Use Factory Certified Parts...

***Friedrich***<sup>®</sup>

FRIEDRICH AIR CONDITIONING CO.  
Visit our web site at [www.friedrich.com](http://www.friedrich.com)

Post Office Box 1540 • 4200 N. Pan Am Expressway • San Antonio, Texas 78295-1540  
• (210) 357-4400 • FAX (210) 357-4490