

Friedrich®

**Room Air Conditioner
Service and Parts
Manual**

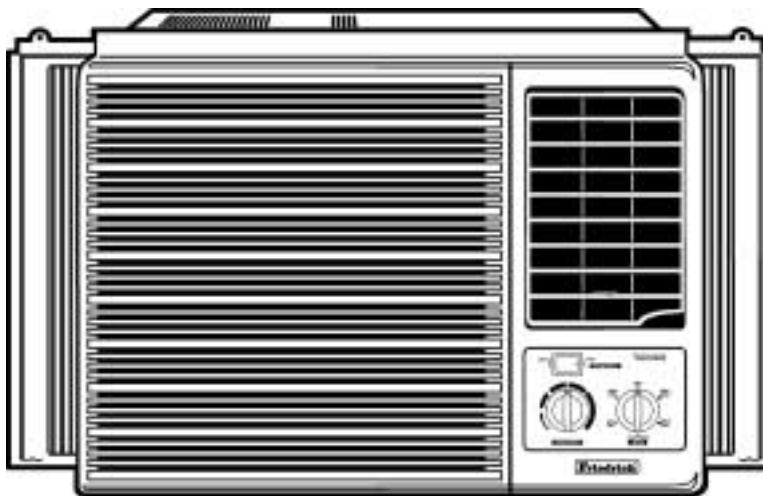

ZStar™

115Volts • ZQ10A10B

CONTENTS

1. PREFACE

1.1 SAFETY PRECAUTIONS.....	2
1.2 INSULATION RESISTANCE TEST	2
1.3 SPECIFICATIONS.....	3
1.4 FEATURES.....	4
1.5 CONTROL LOCATIONS	4

2. DISASSEMBLY INSTRUCTIONS

2.1 MECHANICAL PARTS	5
2.1.1 FRONT GRILLE	5
2.1.2 CABINET	5
2.1.3 CONTROL BOX	5
2.2 AIR HANDLING PARTS	6
2.2.1 AIR GUIDE AND BLOWER	6
2.2.2 FAN AND SHROUD	6
2.3 ELECTRICAL PARTS.....	7
2.3.1 OVERLOAD PROTECTOR	7
2.3.2 COMPRESSOR.....	7
2.3.3 CAPACITOR.....	7
2.3.4 POWER CORD	8
2.3.5 THERMOSTAT	8
2.3.6 ROTARY SWITCH	8
2.3.7 MOTOR	8
2.4 REFRIGERATION CYCLE	9
2.4.1 CONDENSER.....	9
2.4.2 EVAPORATOR.....	9
2.4.3 CAPILLARY TUBE	9

3. INSTALLATION

3.1 INSTALLATION HARDWARE.....	12
3.2 SELECT THE BEST LOCATION	12
3.3 WINDOW REQUIREMENTS	13
3.4 STORM WINDOW REQUIREMENTS	13
3.5 PREPARING THE UNIT FOR INSTALLATION	14
3.6 BEFORE INSTALLATION.....	14
3.7 INSTALL THE CASE IN THE WINDOW	15
3.8 INSTALL THE WINDOW LOCKING BRACKET AND THE FOAM TOP WINDOW GASKET	15
3.9 INSTALL THE AIR CONDITIONER IN THE CASE ...	16
3.10 TO REVERSE THE GRILLE OPENING	16

4. TROUBLESHOOTING GUIDE

4.1 OUTSIDE DIMENSIONS.....	17
4.2 PIPING SYSTEM.....	18
4.3 TROUBLESHOOTING GUIDE	19

5. SCHEMATIC DIAGRAM

• CIRCUIT DIAGRAM	24
-------------------------	----

6. EXPLODED VIEW

7. REPLACEMENT PARTS LIST

1. PREFACE

This **SERVICE MANUAL** provides various service information, the mechanical and electrical parts etc. This room air conditioner was manufactured and assembled under a strict quality control system. The refrigerant is charged at the factory. Be sure to read the safety precautions prior to servicing the unit.

1.1 SAFETY PRECAUTIONS

1. When servicing the unit, set the **ROTARY SWITCH** or **POWER SWITCH** to **OFF** and unplug the power cord.
2. Observe the original lead dress.
If a short circuit is found, replace all parts which have been overheated or damaged by the short circuit.
3. After servicing the unit, make an insulation resistance test to protect the customer from being exposed to shock hazards.

1.2 INSULATION RESISTANCE TEST

1. Unplug the power cord and connect a jumper between 2 pins (black and white).
2. The grounding conductor (green or green & yellow) should be open.
3. Measure the resistance value with an ohm meter between the jumpered lead and each exposed metallic part on the equipment at all the positions (except **OFF** or **O**) of the **ROTARY SWITCH**.
4. The value should be over 1M Ω .

1.3 SPECIFICATIONS

MODELS		ZQ10A10B
ITEMS		
POWER SUPPLY		1 \emptyset , 115V, 60Hz
COOLING CAPACITY	(Btu/h)	10,000
INPUT	(W)	1,020
RUNNING CURRENT	(A)	9.2
E.E.R	(Btu/W.h)	9.8
OPERATING TEMPERATURE	INDOOR (°C)	26.7(DB)* 19.4(WB)**
	OUTDOOR (°C)	35(DB) 23.9(WB)
REFRIGERANT (R-22) CHARGE		439g (15.5 oz)
EVAPORATOR		3 ROW 14 STACKS, S-FIN TYPE
CONDENSER		2 ROW 16 STACKS, L-BENDED TYPE
FAN, INDOOR		TURBO FAN
FAN, OUTDOOR		PROPELLER TYPE FAN WITH SLINGER-RING
FAN SPEEDS, FAN/COOLING		2/3
FAN MOTOR		6 POLES
OPERATION CONTROL		ROTARY SWITCH
ROOM TEMP. CONTROL		THERMOSTAT
AIR DIRECTION CONTROL		VERTICAL LOUVER (RIGHT & LEFT)
		HORIZONTAL LOUVER (UP & DOWN)
CONSTRUCTION		SLIDE IN-OUT CHASSIS
PROTECTOR	COMPRESSOR	OVERLOAD PROTECTOR
	FAN MOTOR	INTERNAL THERMAL PROTECTOR
POWER CORD		1.8m(7') (3 WIRE WITH GROUING)
		ATTACHMENT PLUG (CORD-CONNECTED TYPE)
DRAIN SYSTEM		DRAIN PIPE OR SPLASHED BY FAN SLINGER
NET WEIGHT	(lbs/kg)	70/32
OUTSIDE DIMENSION (W x H x D)	inch	18 ¹ / ₂ x 13 ⁷ / ₈ x 20 ¹¹ / ₁₆
	mm	470 x 353 x 525

* DB : dry bulb

** WB : wet bulb

1.4 FEATURES

- Designed for cooling only.
- Powerful and whisper cooling.
- Slide-in and slide-out chassis for the simple installation and service.
- Side air-intake, side cooled-air discharge.

- Built in adjustable THERMOSTAT.
- Washable one-touch filter.
- Compact size.
- Reliable and efficient rotary compressor equipped.

1.5 CONTROL LOCATIONS

1.5.1 CONTROL ONLY MODEL

• VENTILATION

The ventilation lever must be in the CLOSE position in order to maintain the best cooling conditions. When fresh air is necessary in the room, set the ventilation lever to the OPEN position. The damper is opened and room air is exhausted.

NOTE

Before using the ventilation feature, make a ventilation kit. First, pull down part (A) to horizontal line with part (B).

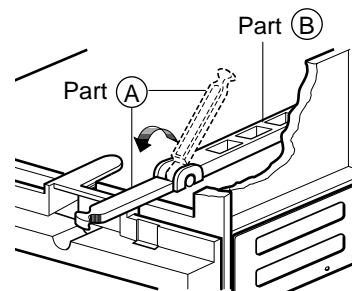
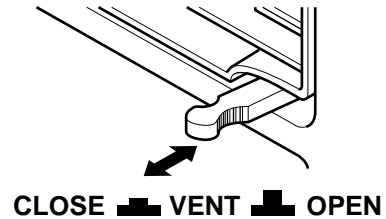

• FOR NORMAL COOLING

1. Turn the Mode switch to the **High, Med** or **Low Cool** setting.
2. Set the Temperature control to the desired temperature point (the mid-point is a good starting position). If the room temperature is not satisfactory after a reasonable time, adjust the control to a cooler or warmer setting, as appropriate.

• FOR MAXIMUM COOLING

1. Turn the Mode switch to the **High Cool** setting.
2. Set the temperature control to the highest temperature point (all the way to the right).

• FOR QUIETER OPERATION

1. Turn the Mode switch to the **Low Cool** setting.
2. Set the Temperature control as needed.

• Energy Saver Switch

This rocker switch can be depressed to either **YES** or **NO**. In the **YES** position, you will get the most economical operation. Both the fan and the compressor will cycle on and off together, maintaining the selected temperature at a more constant level and reducing the humidity more efficiently. This control will only operate when the unit is in a cooling mode. In the **NO** position, the fan will run constantly as long as the unit is in the cooling mode.

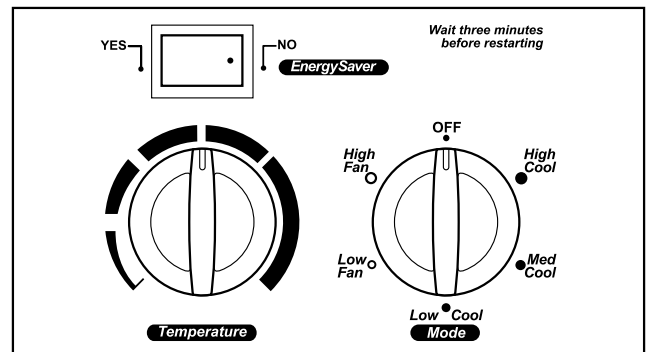

2. DISASSEMBLY INSTRUCTIONS

— Before disassembling, turn the POWER SWITCH to OFF and disconnect the power cord.

2.1 MECHANICAL PARTS

2.1.1 FRONT GRILLE

1. Open the INLET GRILLE downward and remove the air filter.
2. Remove the screw which fastens the FRONT GRILLE.
3. Pull the FRONT GRILLE from the right side.
4. Remove the FRONT GRILLE.
5. Re-install the component by referring to the above removal procedure. (See figure 1)

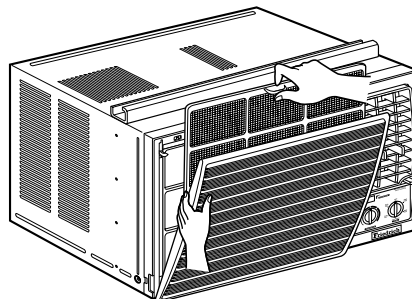

Figure 1

2.1.2 CABINET

1. After disassembling the FRONT GRILLE, remove two screws which fasten the CABINET at both sides.
2. Remove two screws which fasten the CABINET at back.
3. Pull the BASE PAN forward. (See figure 2)

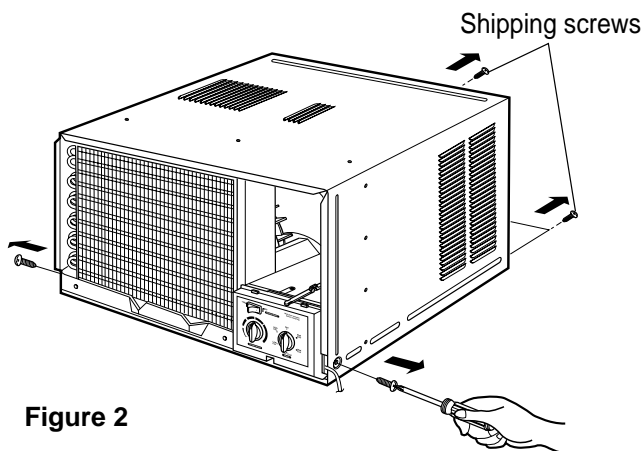

Figure 2

2.1.3 CONTROL BOX

1. Disconnect the unit from the power source.
2. Remove the front grille. (Refer to section 2.1.1)
3. Remove the cabinet. (Refer to section 2.1.2)
4. Remove the screw which fastens the control box cover.
5. Remove the housing which connects motor wire in the control box.
6. Remove the 3 leads from the compressor. (Refer to section 2.3.1)
7. Discharge the capacitor by placing a 20,000 ohm resistor across the capacitor terminals.
8. Remove the 2 screws which fasten the control box. (See Figure 3)
9. Pull the control box forward completely.
10. Re-install the components by referring to the removal procedure, above. (See Figure 3)
(Refer to the circuit diagram found on page 24 in this manual or on the control box.)

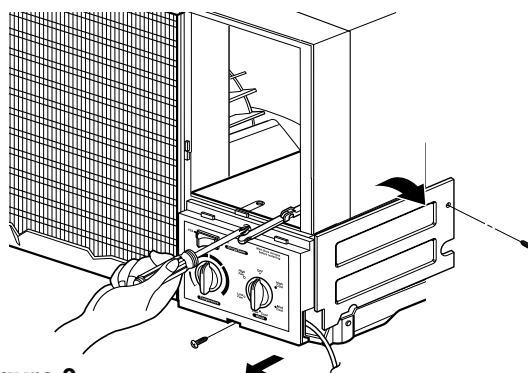

Figure 3

2.2 AIR HANDLING PARTS

2.2.1 AIR GUIDE AND BLOWER

1. Remove the front grille. (Refer to section 2.1.1)
2. Remove the cabinet. (Refer to section 2.1.2)
3. Remove the control box. (Refer to section 2.1.3)
4. Remove the 3 screws which fasten the brace.
5. Remove the brace.
6. Remove the 2 screws which fasten the evaporator.
7. Move the evaporator forward and pulling it upward slightly. (See Figure 4)
8. Move the evaporator to the left carefully.
9. Pull out the hook of orifice by pushing the tabs and remove it. (See Figure 5)
10. Remove the clamp with a hand plier which secures the blower.
11. Remove the blower.
12. Remove the 4 screws which fasten the air guide from the barrier.
13. Move the air guide backward, pulling out from the base pan.
14. Re-install the components by referring to the removal procedure, above.

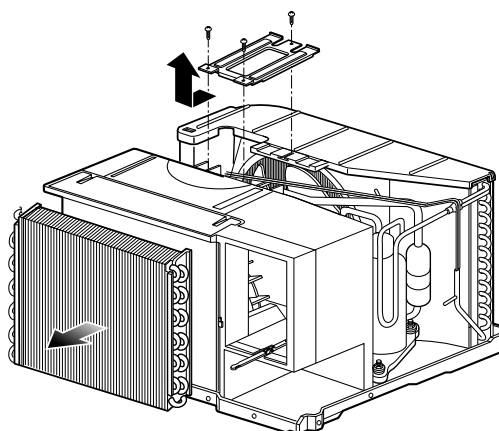

Figure 4

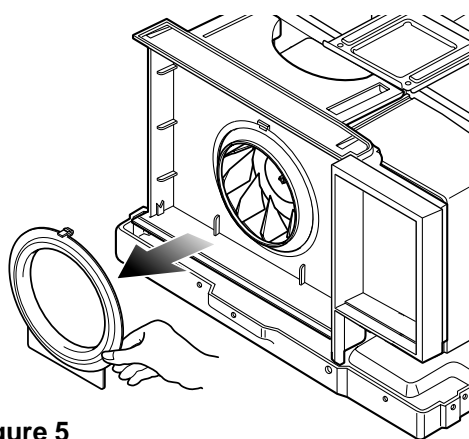

Figure 5

2.2.2 FAN AND SHROUD

1. Remove the cabinet. (Refer to section 2.1.2)
2. Remove the brace (Refer to section 2.2.1)
3. Remove the screw which fastens the cover cond.
4. Remove the 5 screws which fasten the condenser.
5. Move the condenser to the left carefully.
6. Remove the clamp with a hand plier which secures the fan.
7. Remove the fan and then pull out the shroud. (See Figure 6)
8. Re-install the components by referring to the removal procedure.

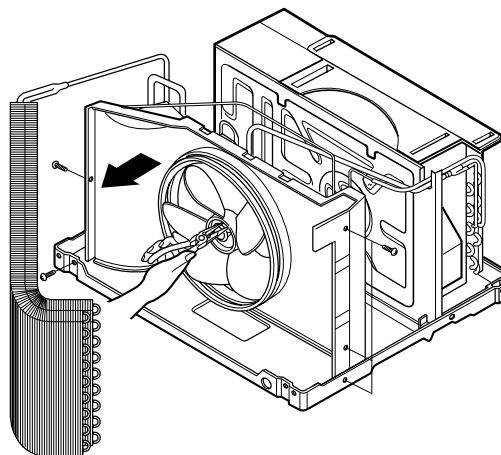

Figure 6

2.3 ELECTRICAL PARTS

2.3.1 OVERLOAD PROTECTOR

1. Remove the cabinet. (Refer to section 2.1.2)
2. Remove the nut which fastens the terminal cover.
3. Remove the terminal cover. (See Figure 7)
4. Remove all the leads from the overload protector.
5. Remove the overload protector.
6. Re-install the component by referring to the removal procedure, above.

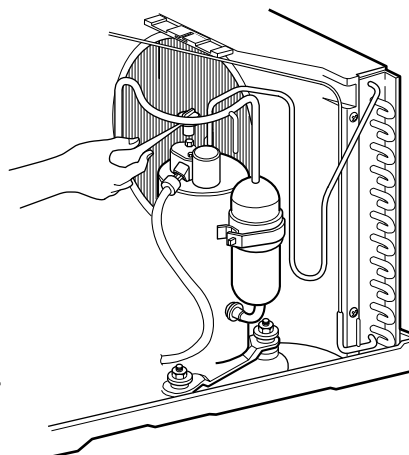

Figure 7

2.3.2 COMPRESSOR

1. Remove the cabinet. (Refer to section 2.1.2)
2. Discharge the refrigerant system using a Freon™ Recovery System.
If there is no valve to attach the recovery system, install one (such as a WATCO A-1) before venting the Freon™. Leave the valve in place after servicing the system.
3. Remove the overload protector. (Refer to section 2.3.1)
4. After purging the unit completely, unbraid the suction and discharge tubes at the compressor connections.
5. Remove the 3 nuts and the 3 washers which fasten the compressor.
6. Remove the compressor. (See Figure 8)
7. Re-install the components by referring to the removal procedure, above.

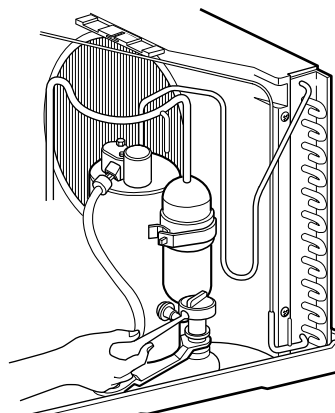

Figure 8

2.3.3 CAPACITOR

1. Remove the control box. (Refer to section 2.1.3)
2. Remove the knobs and the screw which fasten control panel from control box.
3. Remove the screw which is located in the front.
4. Open the bottom side of control box.
5. Remove the screw and the clamp which fasten the capacitor.
6. Disconnect all the leads of capacitor terminals.
7. Re-install the components by referring to the removal procedure, above. (See Figure 9)

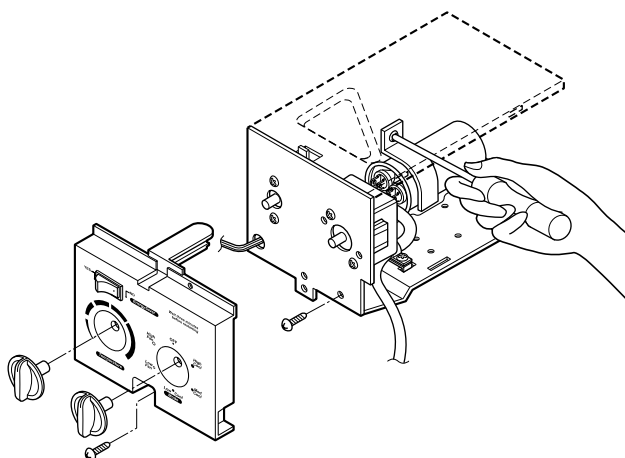

Figure 9

2.3.4 POWER CORD

1. Remove the control box. (Refer to section 2.1.3)
2. Open the control box. (Refer to section 2.3.3)
3. Disconnect the grounding screw from the control box.
4. Disconnect the 2 receptacles.
5. Remove a screw which fastens the clip cord. (See Figure 10)
6. Remove the power cord.
7. Re-install the component by referring to the above removal procedure, above. (Use only one ground-marked hole \oplus for ground connection.)
8. If the supply cord of this appliance is damaged, it must be replaced by the special cord. (The special cord means the cord which has the same specification marked on the supply cord attached at the unit.)

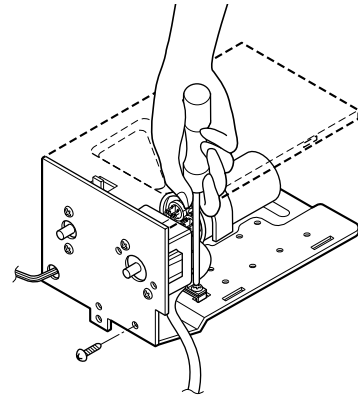

Figure 10

2.3.5 THERMOSTAT

1. Remove the control box. (Refer to section 2.1.3)
2. Open the control box. (Refer to section 2.3.3)
3. Remove the 2 screws which fasten the thermostat.
4. Disconnect 2 leads of thermostat terminals.
5. Remove the thermostat.
6. Re-install the components by referring to the above removal procedure. (See Figure 11)

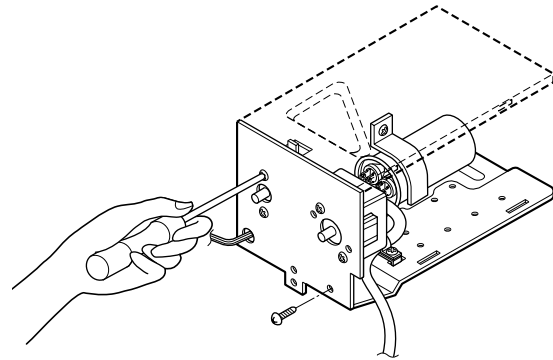

Figure 11

2.3.6 ROTARY SWITCH

1. Remove the control box. (Refer to section 2.1.3)
2. Open the control box. (Refer to section 2.3.3)
3. Remove the 2 screws which fasten the rotary switch.
4. Disconnect all the leads of the rotary switch terminals.
5. Remove the rotary switch.
6. Re-install the components by referring to the above removal procedure. (See Figure 12)

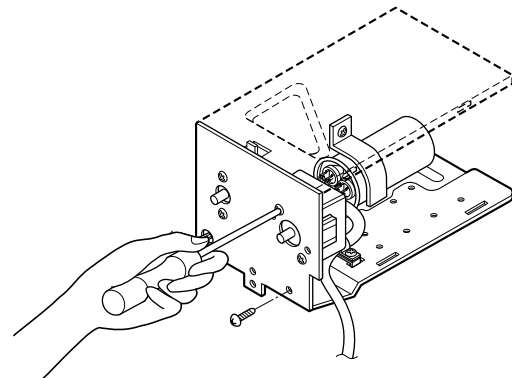

Figure 12

2.3.7 MOTOR

1. Remove the cabinet. (Refer to section 2.1.2)
2. Remove the evaporator. (Refer to section 2.2.1)
3. Remove the orifice. (Refer to section 2.2.1)
4. Remove the blower. (Refer to section 2.2.1)
5. Remove the fan. (Refer to section 2.2.2)
6. Remove the control box cover and housing of the motor in the control box. (Refer to section 2.1.3)
7. Remove the 2 screws which fasten the motor from the mount motor. (See Figure 13)
8. Remove the motor.
9. Re-install the components by referring to the removal procedure, above. (See Figure 13)

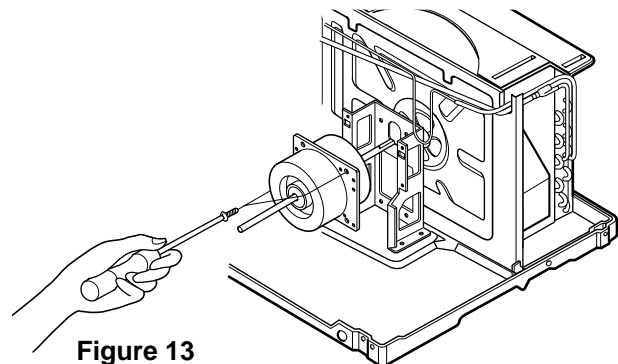

Figure 13

2.4 REFRIGERATING CYCLE

CAUTION

Discharge the refrigerant system using a Freon™ Recovery System. If there is no valve to attach the recovery system, install one (such as a WATCO A-1) before venting the Freon™. Leave the valve in place after servicing the system.

2.4.1 CONDENSER

1. Remove the cabinet. (Refer to section 2.1.2)
2. Remove the 3 screws which fasten the brace.(Refer to section 2.2.1)
3. Remove the screw which fastens the cover cond.
4. Remove the 5 screws which fasten the condenser and shroud.
5. After discharging the refrigerant completely, unbrazed the interconnecting tube at the condenser connections.
6. Remove the condenser carefully.
7. Re-install the components by referring to the removal procedure.
(See Figure 14)

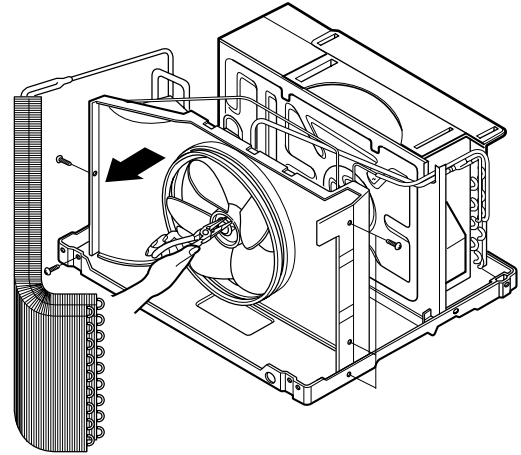

Figure 14

2.4.2 EVAPORATOR

1. Remove the cabinet. (Refer to section 2.1.2)
2. Remove the 2 screws which fasten the evaporator.
3. Move the evaporator sideways carefully.
(Refer to section 2.2.1)
4. After discharging the refrigerant completely, unbrazed the interconnecting tube at the evaporator connections.
5. Remove the evaporator carefully.
6. Re-install the component by referring to notes.
(See Figure 15)

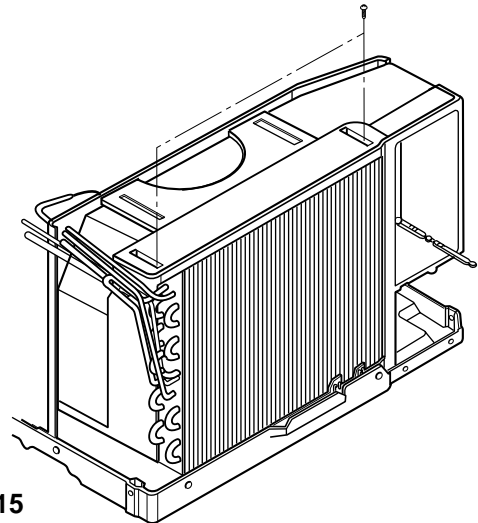

Figure 15

2.4.3 CAPILLARY TUBE

1. Remove the cabinet. (Refer to section 2.1.2)
2. After discharging the refrigerant completely, unbrazed the interconnecting tube at the capillary tube.(See caution above)
3. Remove the capillary tube.
4. Re-install the component by referring to notes.

NOTES

— Replacement of the refrigeration cycle.

1. When replacing the refrigeration cycle, be sure to Discharge the refrigerant system using a Freon™ recovery System.
If there is no valve to attach the recovery system, install one (such as a WATCO A-1) before venting the Freon™. Leave the valve in place after servicing the system.
2. After discharging the unit completely, remove the desired component, and unbrazed the pinch-off tubes.
3. Solder service valves into the pinch-off tube ports, leaving the valves open.
4. Solder the pinch-off tubes with Service valves.
5. Evacuate as follows.
 - 1) Connect the vacuum pump, as illustrated figure 16A.
 - 2) Start the vacuum pump, slowly open manifold valves A and B with two full turns counterclockwise and leave the valves open. The vacuum pump is now pulling through valves A and B up to valve C by means of the manifold and entire system.

CAUTION

If high vacuum equipment is used, just crack valves A and B for a few minutes, then open slowly with the two full turns counterclockwise. This will keep oil from foaming and being drawn into the vacuum pump.

- 3) Operate the vacuum pump for 20 to 30 minutes, until 600 microns of vacuum is obtained. Close valves A and B, and observe vacuum gauge for a few minutes. A rise in pressure would indicate a possible leak or moisture remaining in the system. With valves A and B closed, stop the vacuum pump.
- 4) Remove the hose from the vacuum pump and place it on the charging cylinder. See figure 16B.
Open valve C.
Discharge the line at the manifold connection.
- 5) The system is now ready for final charging.

6. Recharge as follows :

- 1) Refrigeration cycle systems are charged from the High-side. If the total charge cannot be put in the High-side, the balance will be put in the suction line through the access valve which you installed as the system was opened.
- 2) Connect the charging cylinder as shown in figure 16B.
With valve C open, discharge the hose at the manifold connection.
- 3) Open valve A and allow the proper charge to enter the system. Valve B is still closed.
- 4) If more charge is required, the high-side will not take it. Close valve A.
- 5) With the unit running, open valve B and add the balance of the charge.
 - a. Do not add the liquid refrigerant to the Low-side.
 - b. Watch the Low-side gauge; allow pressure to rise to 30 lbs.
 - c. Turn off valve B and allow pressure to drop.
 - d. Repeat steps b. and c. until the balance of the charge is in the system.
- 6) When satisfied the unit is operating correctly, use the pinch-off tool with the unit still running and clamp on to the pinch-off tube. Using a tube cutter, cut the pinch-off tube about 2 inches from the pinch-off tool. Use sil-fos solder and solder pinch-off tube closed. Turn off the unit, allow it to set for a while, and then test the leakage of the pinch-off connection.

Equipment needed: Vacuum pump, Charging cylinder, Manifold gauge, Brazing equipment. Pin-off tool capable of making a vapor-proof seal, Leak detector, Tubing cutter, Hand Tools to remove components, Service valve.

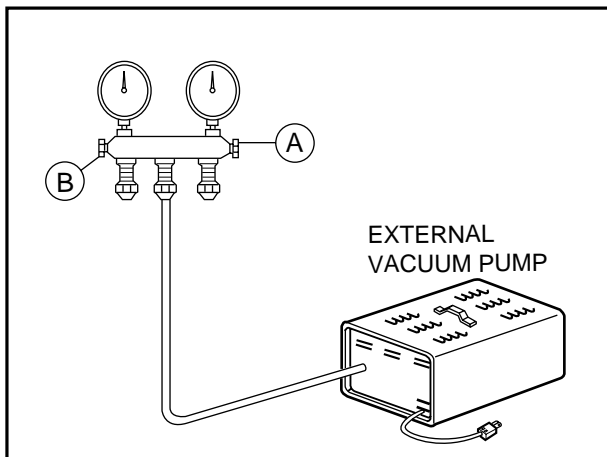
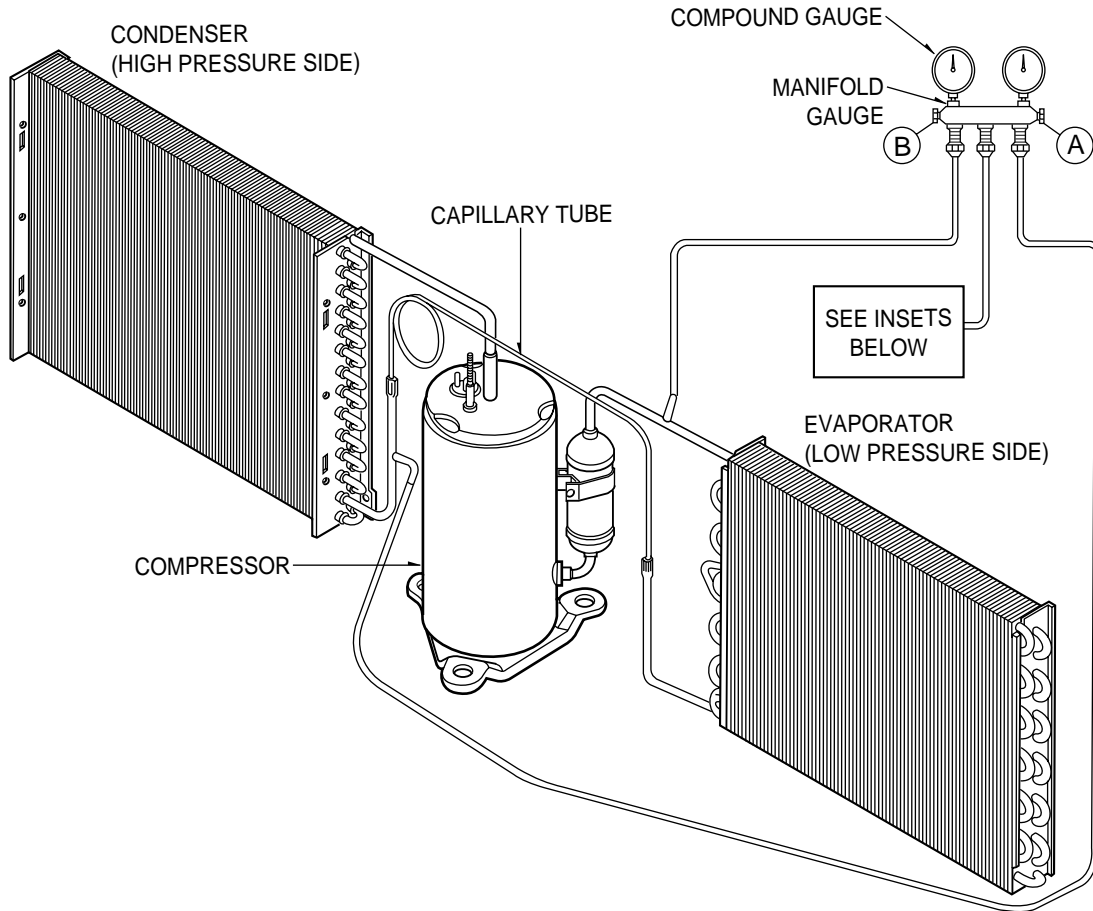

Figure 16A-Pulling Vacuum

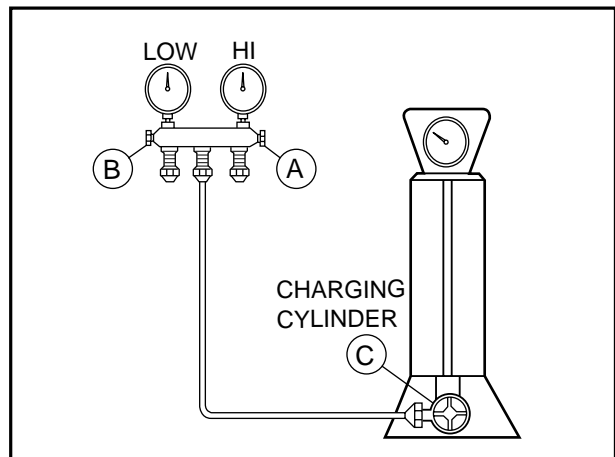
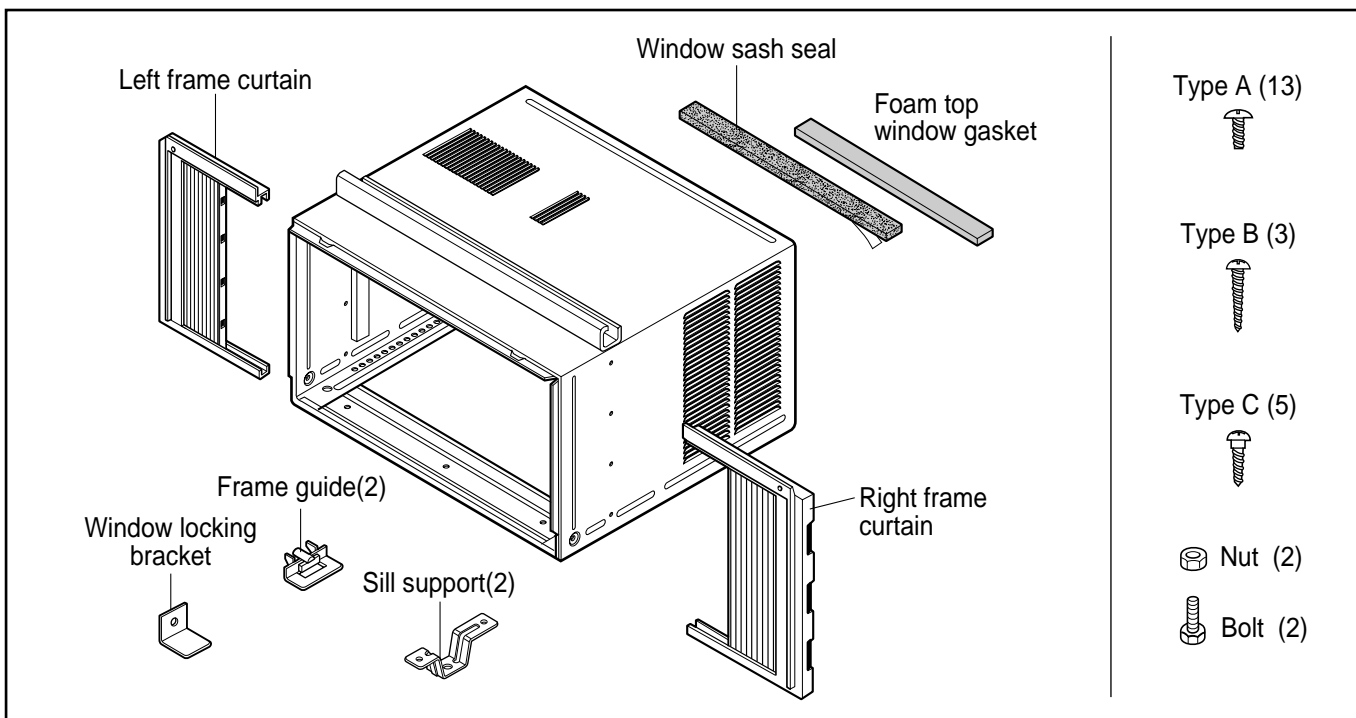

Figure 16B-Charging

3. INSTALLATION

3.1 INSTALLATION HARDWARE



3.2 SELECT THE BEST LOCATION

- Step 1. To prevent vibration and noise, make sure the unit is installed securely and firmly
- Step 2. If possible, install the unit where sunlight does not shine directly on the unit.
- Step 3. The outside of the cabinet must extend outward for at least 11" and there should be no obstacles, such as a fence or wall, within 20" from the back of the cabinet because it will prevent heat radiation of the condenser. Restriction of outside air will greatly reduce the cooling efficiency of the air conditioner.
- Step 4. Install the unit with a little tilt outward not to leak the condensed water into the room (about 10-15cm or 1/4 bubble with level).

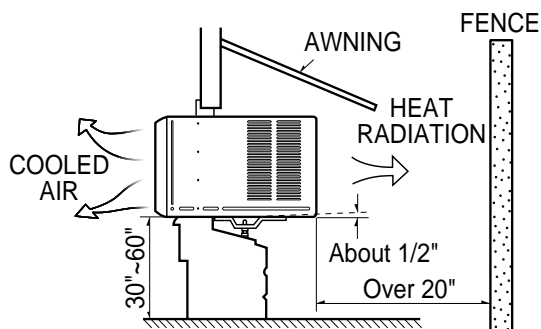

CAUTION: All side louvers of the cabinet must remain exposed to the outside of the structure.

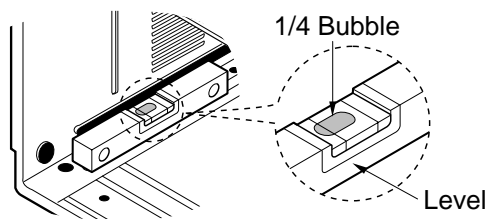

3.3 WINDOW REQUIREMENTS

- Step 1. These instructions are for a standard double hung window. You will need to modify them for other types of windows.
- Step 2. The air conditioner can be installed without the frame curtain if needed to fit in a narrow window. See the window opening dimensions to the right.
- Step 3. All supporting parts must be secured to firm wood, masonry, or metal.
- Step 4. The electric outlet must be within reach of the power cord.

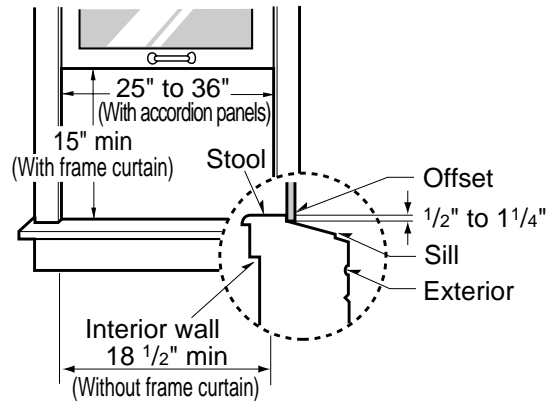

3.4 STORM WINDOW REQUIREMENTS

A storm window frame will not allow the air conditioner to tilt toward the outside and will keep it from draining properly. To adjust for this, attach a piece of wood to the stool.

WOOD PIECES-

Width: Minimum 1 1/2" (38mm)

Length: Long enough to fit inside the window frame.

Thickness: To determine the thickness, place a piece of wood on the stool to make it 1/2" higher than the top of the storm window frame.

Attach securely with nails or screws provided.

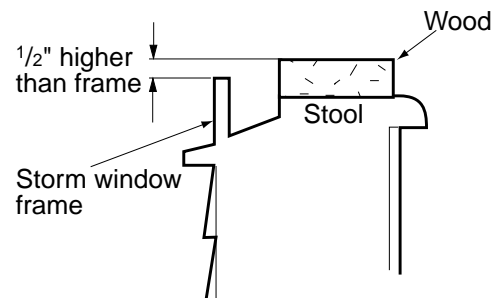

3.5 PREPARING THE UNIT FOR INSTALLATION

- ✓ Remove the 2 shipping screws from the back of the case.
- ✓ Remove the 2 screws on each side of the case. Keep these for later use.
- ✓ Slide the air conditioner from the case by gripping the base pan handle and pulling forward while bracing the case.

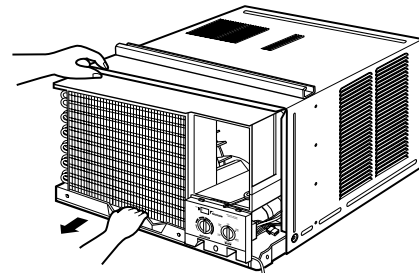
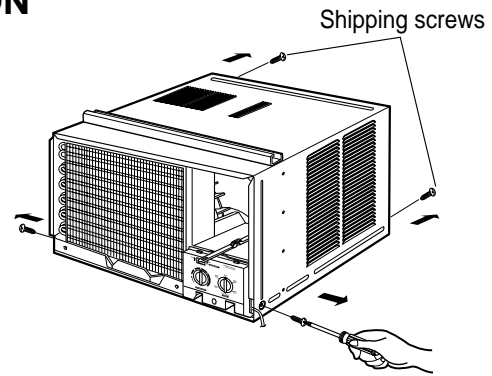

3.6 BEFORE INSTALLATION...

- ✓ Cut the window sash seal to the proper length. Peel off the backing and attach the seal to the underside of the window sash.
- ✓ Carefully insert the plastic frame guides into the bottom of the case on each side. When the frame guides are set, the arrows should be pointing toward the back end of the unit.
- ✓ Insert the frames for the frame curtains into the top mounting rail and the frame guides. Attach the frame curtains to the side of the case using 4 type A screws

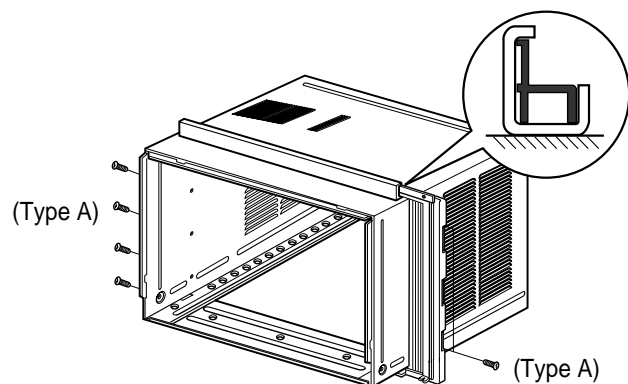
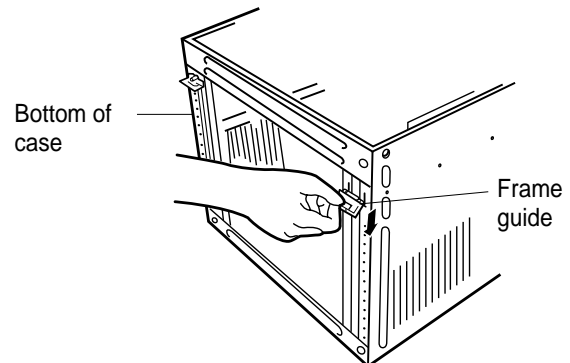
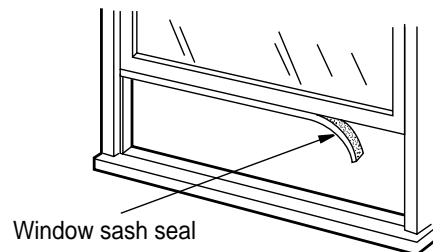

3.7 INSTALL THE CASE IN THE WINDOW

- Step 1. Open the window and mark the centerline of the window stool (or desired air conditioner location).
- Step 2. Carefully place the case on the window stool and align the center mark on the bottom front with the centerline of the stool.
- Step 3. Pull the window down behind the top mounting rail.

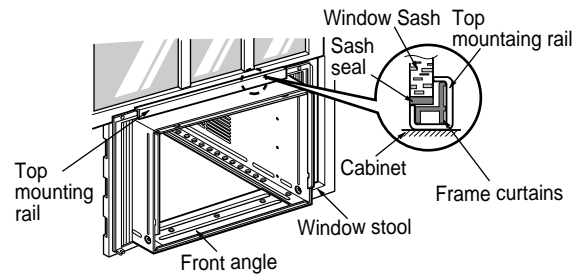

NOTE: Do not shut the window so tightly that movement of the frame curtains is restricted.

- Step 4. Loosely assemble the sill supports.

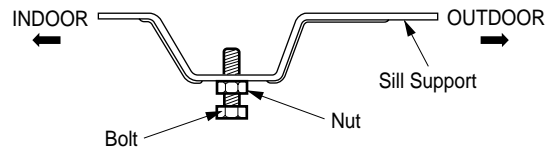

- Step 5. Select the position that will place the sill supports near the outermost point on the sill. Attach the sill supports to the case track hole in relation to the selected position using 2 type A screws in each support.

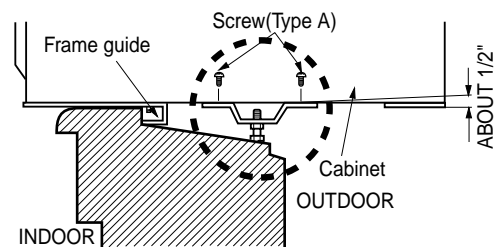

- Step 6. Adjust the bolt and the nut in each support so that the case is installed with a slight downward tilt (about 1/2").

- Step 7. Secure the case to the window stool by using 3 type B screws.

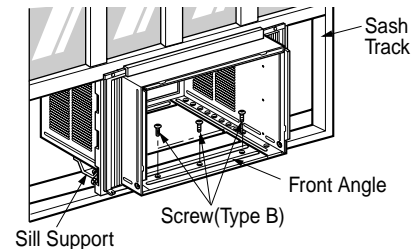

- Step 8. Pull the frame curtains to each window sash track. Attach them on each side to the window sash and the window stool using 4 type C screws.

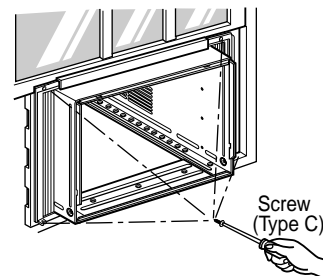

3.8 INSTALL THE WINDOW LOCKING BRACKET AND THE FOAM TOP WINDOW GASKET

- Step 1. Attach the window locking bracket with type C screw.

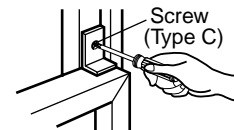

- Step 2. Cut the foam top window gasket to the window width.

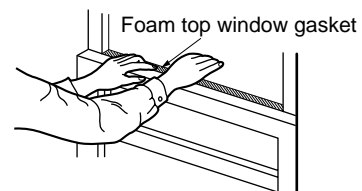

- Step 3. Stuff the foam between the glass and the window to prevent air and insects from getting into the room.

3.9 INSTALL THE AIR CONDITIONER IN THE CASE

Step 1. Slide the air conditioner into the case. Reinstall the 2 screws removed earlier on each side of the case.

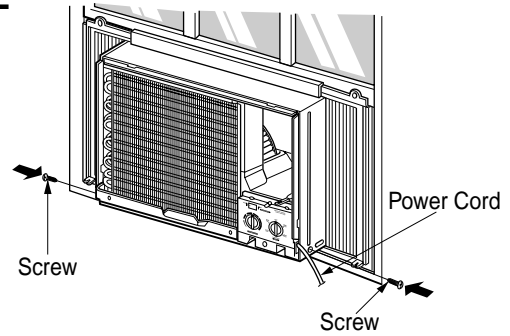

Step 2. Before installing the front grille, pull out the vent control lever located above the unit control knobs, as shown.

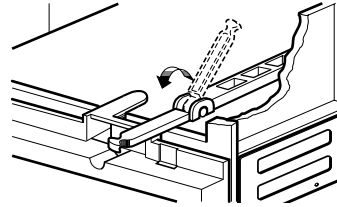

Step 3. Attach the front grille to the case by inserting the tabs on the grille into the slots on the front of the case. Push the grille in until it snaps into place.

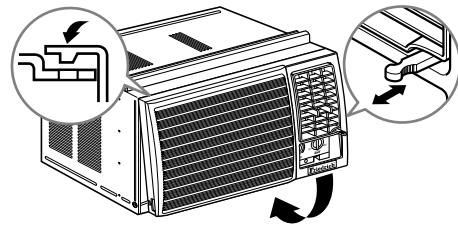

When you detach the front grille from the case, push the grille to your right side and pull it toward you.

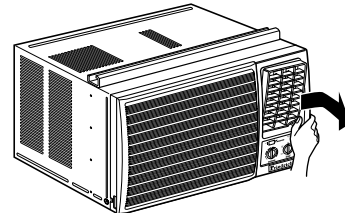

Step 4. Lift the inlet grille and secure the front grille with a type A screw. Lower the inlet grille into place.

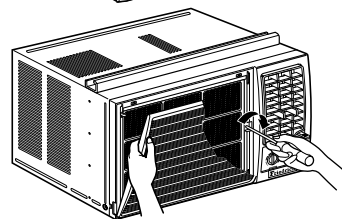

3.10 TO REVERSE THE GRILLE OPENING

The Friedrich ZQ08A10A has a reversible grille. The grille is designed to open from both the top and the bottom.

To reverse the grille opening, you must follow the following steps;

- Step 1. Pull the entire grill of the front of the unit and locate the hinges that hold the grille in place on the inside of the grille.
- Step 2. Insert the tip of a flat screwdriver in between one of the Hinges and the ball shaped bearing of the grille.
- Step 3. Very carefully pull the bearing out of the socket of the Hinge and repeat steps 1-3 for the remaining hinge and socket.
- Step 4. Locate the top hinges on the grille.
- Step 5. Turn the grille upside down and using flat screwdriver, create an opening on the top hinge and insert the ball shaped bearing to snap the grille in place. Repeat the same steps on the remaining hinge.

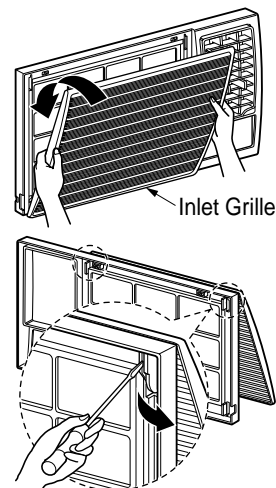

4. TROUBLESHOOTING GUIDE

4.1 OUTSIDE DIMENSIONS

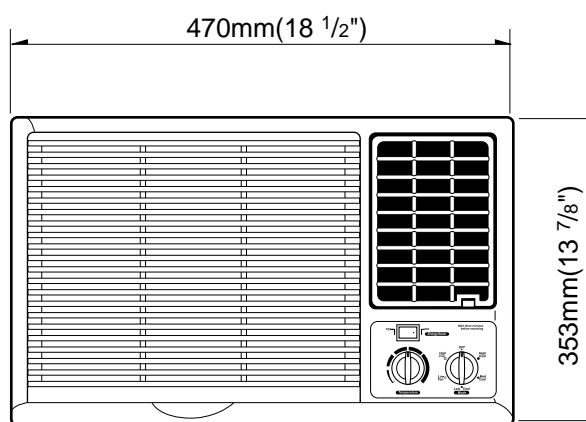
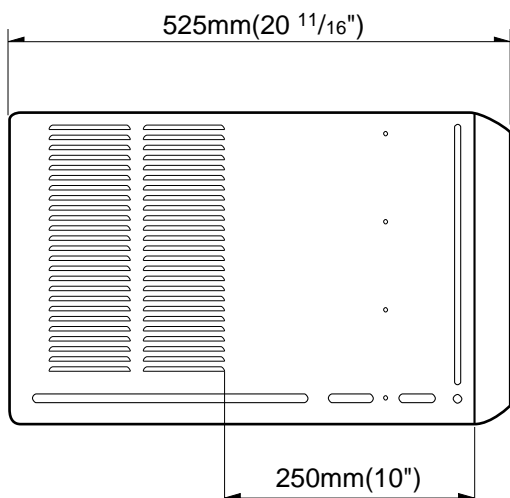

4.2 PIPING SYSTEM

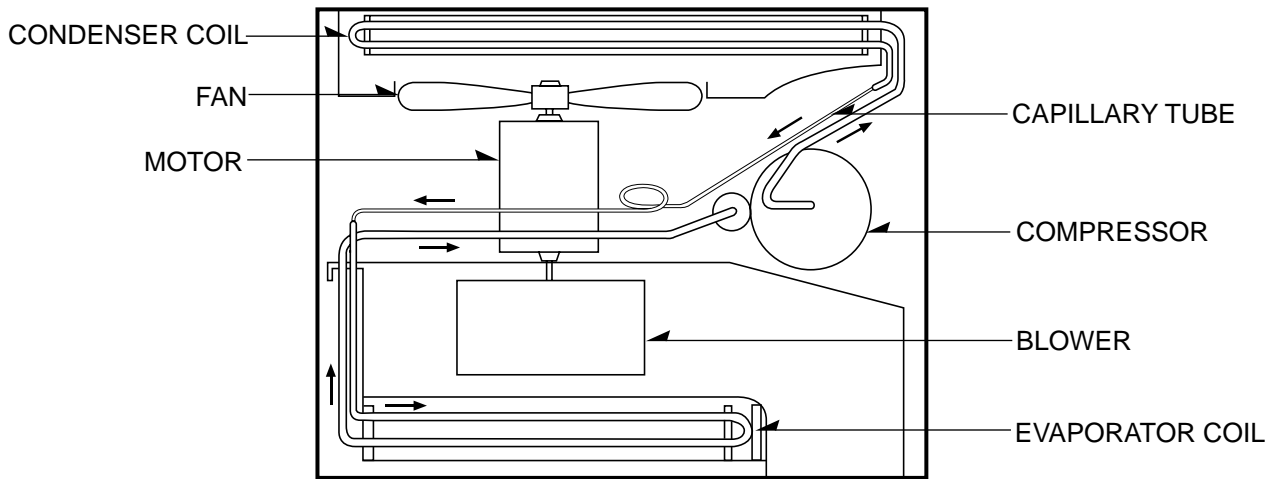

Discharge the refrigerant system using a Freon™ Recovery System. If there is no valve to attach the recovery system, install one (such as a WATCO A-1) before venting the Freon™. Leave the valve in place after servicing the system. Do not vent Freon™ into the atmosphere.

→ : REFRIGERANT FLOW

The following is a brief description of the important components and their function in what is called the refrigeration system. Reference should be made to figure 17 to follow the refrigerating cycle and the flow of the refrigerant in the cooling cycle.

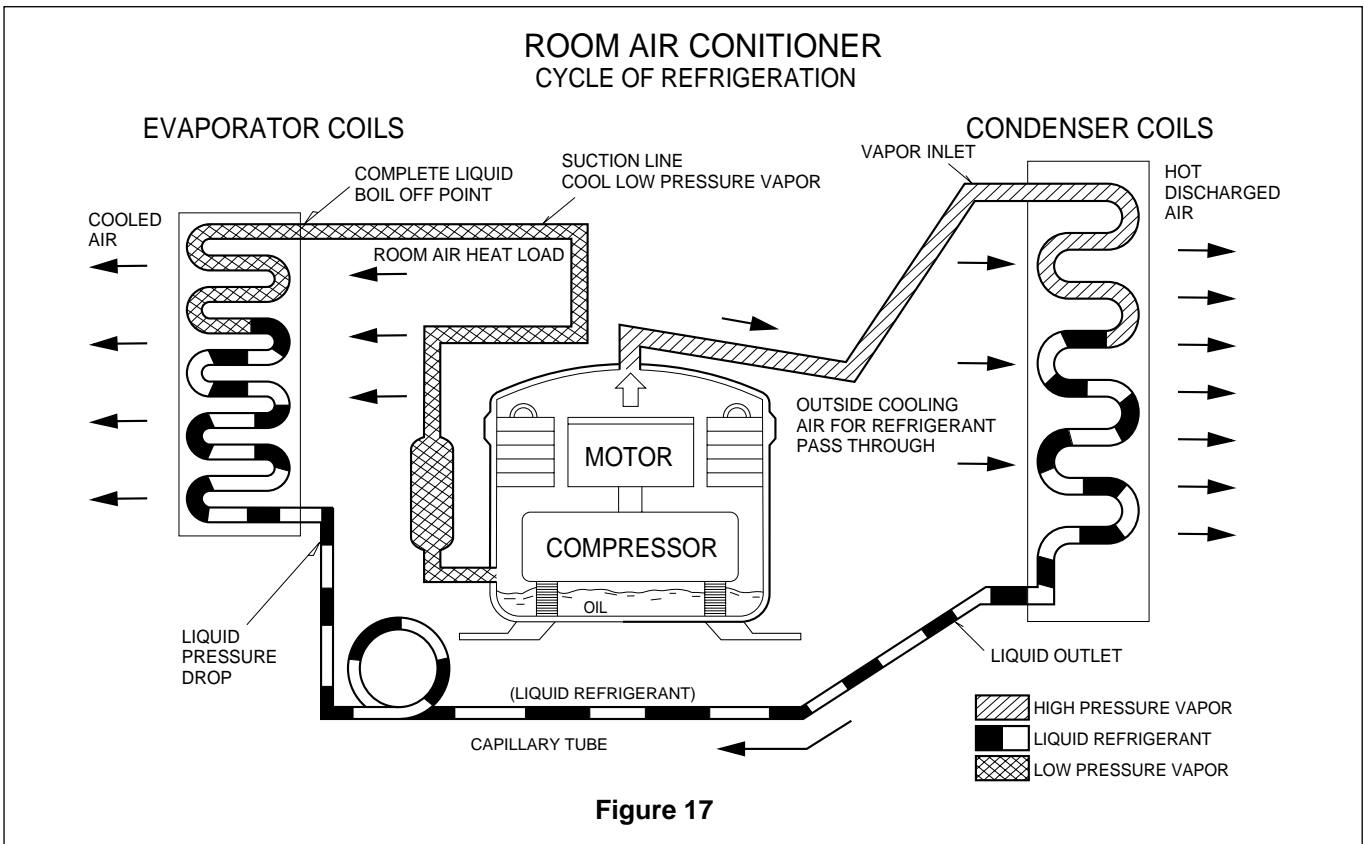

4.3 TROUBLESHOOTING GUIDE

In general, possible trouble is classified in two kinds.

The one is called **Starting Failure** which is caused from an electrical defect. The other is **Ineffective Air Conditioning** caused by a defect in the refrigeration circuit and improper application.

Unit runs but poor cooling is ineffective.

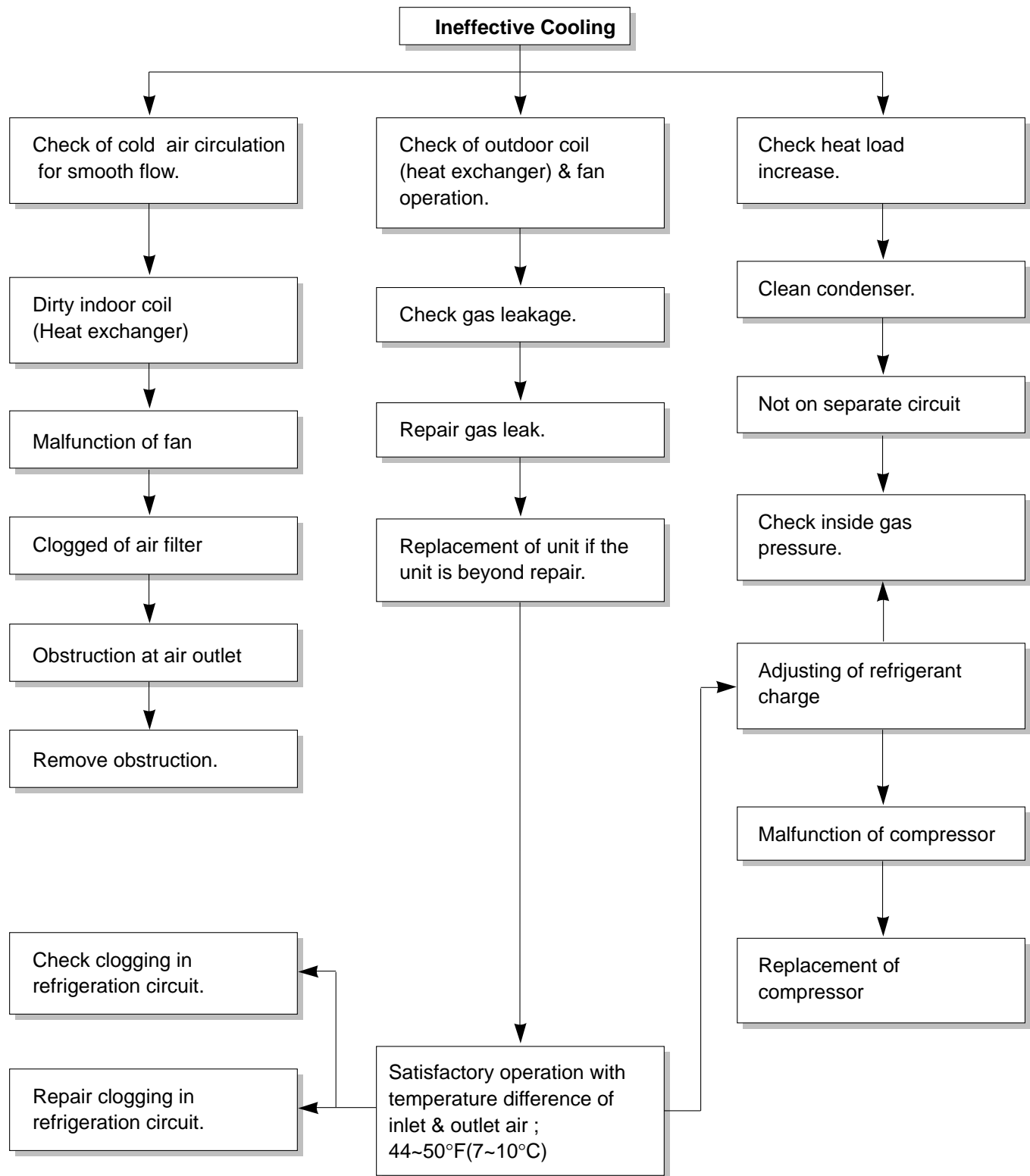

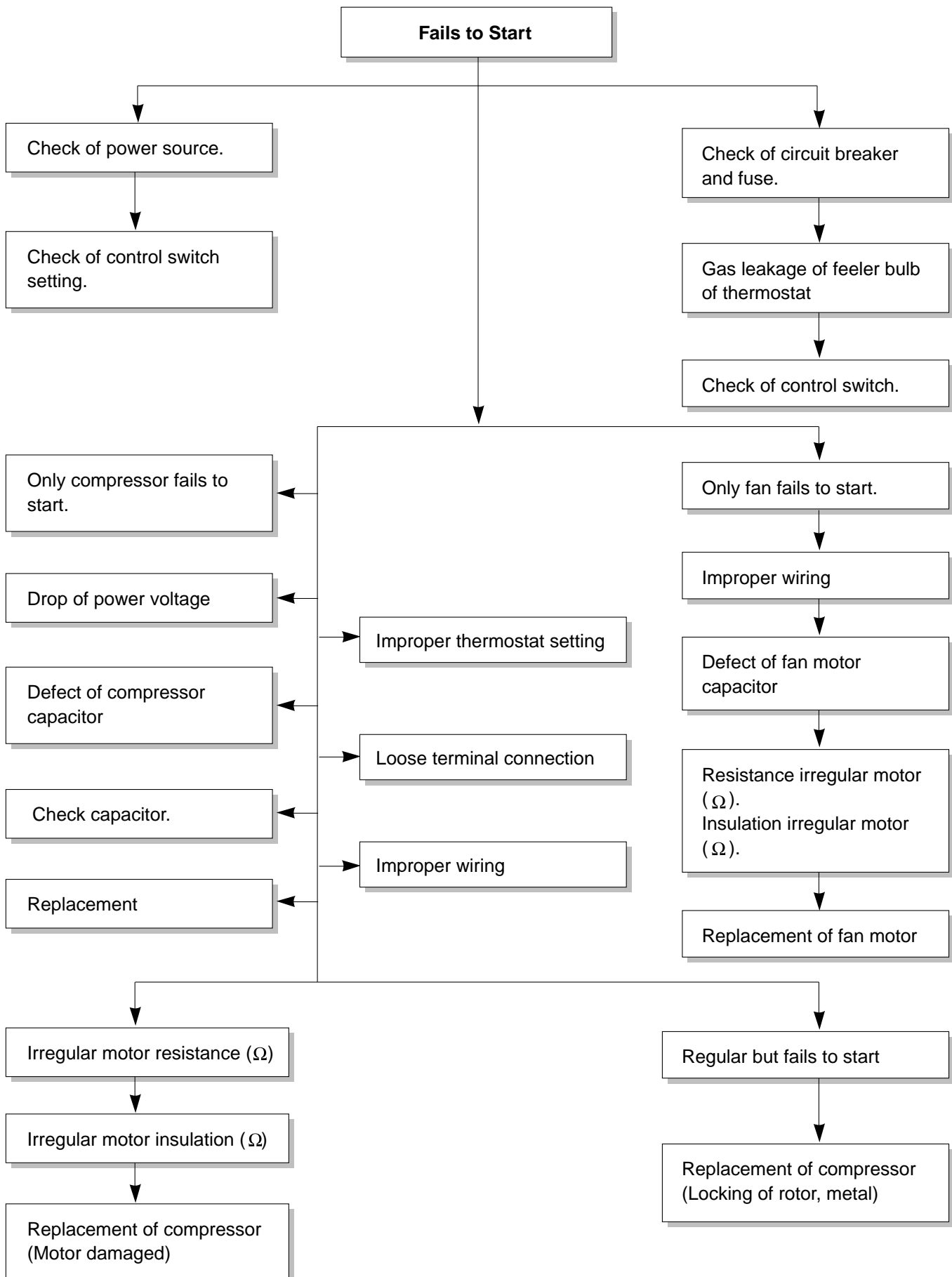

ROOM AIR CONDITIONER VOLTAGE LIMITS

NAME PLATE RATING	MINIMUM	MAXIMUM
115V	103.5V	126.5V

COMPLAINT	CAUSE	REMEDY
Fan motor will not run.	No power	Check voltage at outlet. Correct if none.
	Power supply cord	Check voltage to rotary switch. If none, check power supply cord. Replace cord if circuit is open.
	Rotary switch	Check switch continuity. Refer to wiring diagram for terminal identification. Replace switch if none defective.
	Wire disconnected or connection loose	Connect wire. Refer to wiring diagram for terminal identification. Repair or replace loose terminal.
	Capacitor (Discharge capacitor before testing.)	Test capacitor. Replace if not within $\pm 10\%$ of manufacturer's rating. Replace if shorted, open, or damaged.
	Will not rotate	Fan blade hitting shroud or blower wheel hitting scroll. Realign assembly. Units using slinger ring condenser fans must have $\frac{2}{9}$ to $\frac{1}{4}$ inch clearance to the base. If it is the base, shim up the bottom of the fan motor with mounting screw(s). Check fan motor bearings; if motor shaft will not rotate, replace the motor.
Fan motor runs intermittently.	Revolves on overload.	Check voltage. See limits on this page. If not within limits, call an electrician. Test capacitor. Check bearings. Does the fan blade rotate freely? If not, replace fan motor. Pay attention to any change from high speed to low speed. If the speed does not change, replace the motor.

COMPLAINT	CAUSE	REMEDY
Fan motor noise.	Fan	If cracked, out of balance, or partially missing, replace it.
	Blower	If cracked, out of balance, or partially missing, replace it.
	Loose set screw	Tighten it.
	Worn bearings	If knocking sounds continue when running or loose, replace the motor. If the motor hums or noise appears to be internal while running, replace motor.
Compressor will not run, fan motor runs.	Voltage	Check voltage. See the limits on the preceding page. If not within limits, call an electrician.
	Wiring	Check the wire connections ; if loose, repair or replace the terminal. If the wires are disconnected, refer to wiring diagram for identification, and replace the wires. Check the wire connections ; if not according to the wiring diagram, correct the connections.
	Rotary	Check for continuity, refer to the wiring diagram for terminal identification. Replace the switch if the circuit is open.
	Thermostat	Check the position of knob. If not at the coldest setting, advance the knob to this setting and restart the unit.
		Check the continuity of the thermostat. Replace the thermostat if the circuit is open.
	Capacitor (Discharge capacitor before servicing.)	Check the capacitor. Replace if not within $\pm 10\%$ of manufacturer's rating, replace if shorted, open, or damaged.
	Compressor	Check the compressor for open circuit or ground. If open or grounded, replace the compressor.
Overload	Check the compressor overload if externally mounted. Replace if open. (If the compressor temperature is high, remove the overload, cool and retest.)	
Compressor cycles on overload.	Voltage	Check the voltage. See the limits on the preceding page. If voltage is not within these limits, call an electrician.
	Overload	Check overload, if externally mounted. Replace if open. (If the compressor temperature is high, remove the overload, cool, and retest.)

COMPLAINT	CAUSE	REMEDY
Compressor cycles on overload	Fan motor	If not running, determine the cause. Replace if required.
	Condenser air flow restriction	Remove the cabinet, inspect the interior surface of the condenser. If restricted, clean carefully with a vacuum cleaner (do not damage fins) or brush. Clean the interior base before re-assembling.
	Condenser fins (damaged)	If the condenser fins are closed over a large area on the coil surface, head pressures will increase, causing the compressor to cycle. Straighten the fins or replace the coil.
	Capacitor	Test the capacitor.
	Wiring	Check the terminals. If loose, repair or replace.
	Refrigeration system	Check the system for a restriction.
Insufficient cooling	Air filter	If restricted, clean or replace.
	Exhaust damper door	Close if open.
	Unit undersized	Determine if the unit is properly sized for the area to be cooled.
Excessive noise	Blower or fan	Check the set screw, or clamp. If loose or missing, correct. If the blower or fan is hitting scroll or barrier, rearrange the air handling parts.
	Copper tubing	Remove the cabinet and carefully rearrange the tubing not to contact the cabinet, compressor, shroud and barrier.

5. SCHEMATIC DIAGRAM

• CIRCUIT DIAGRAM

• MODEL : ZQ10A10B

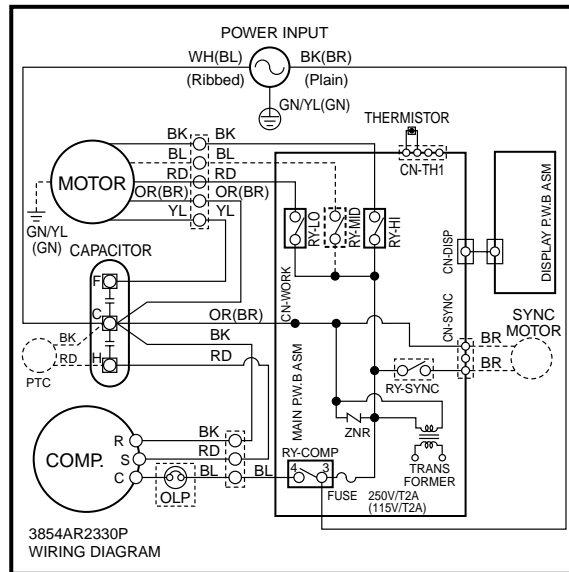

LOCATION NO.	DESCRIPTION	PART NO.	Q'TY PER SET	REMARKS
		ZQ10A10A		
1	POWER CORD ASS'Y	2H00677R	1	
2	MOTOR ASS'Y	4681A20027J	1	
3	COMPRESSOR	2520UKEC2CB	1	
4	ROTARY SWITCH	2H00598E	1	
5	THERMOSTAT	2H01109L	1	
6	CAPACITOR, SH	0CZZA20001N	1	
7	CONNECTOR ASS'Y	6631AR3843P	1	
9	CONNECTOR ASS'Y	6631AR2687R	1	
10	OVERLOAD PROTECTOR	6750U-L049A	1	

6. EXPLODED VIEW

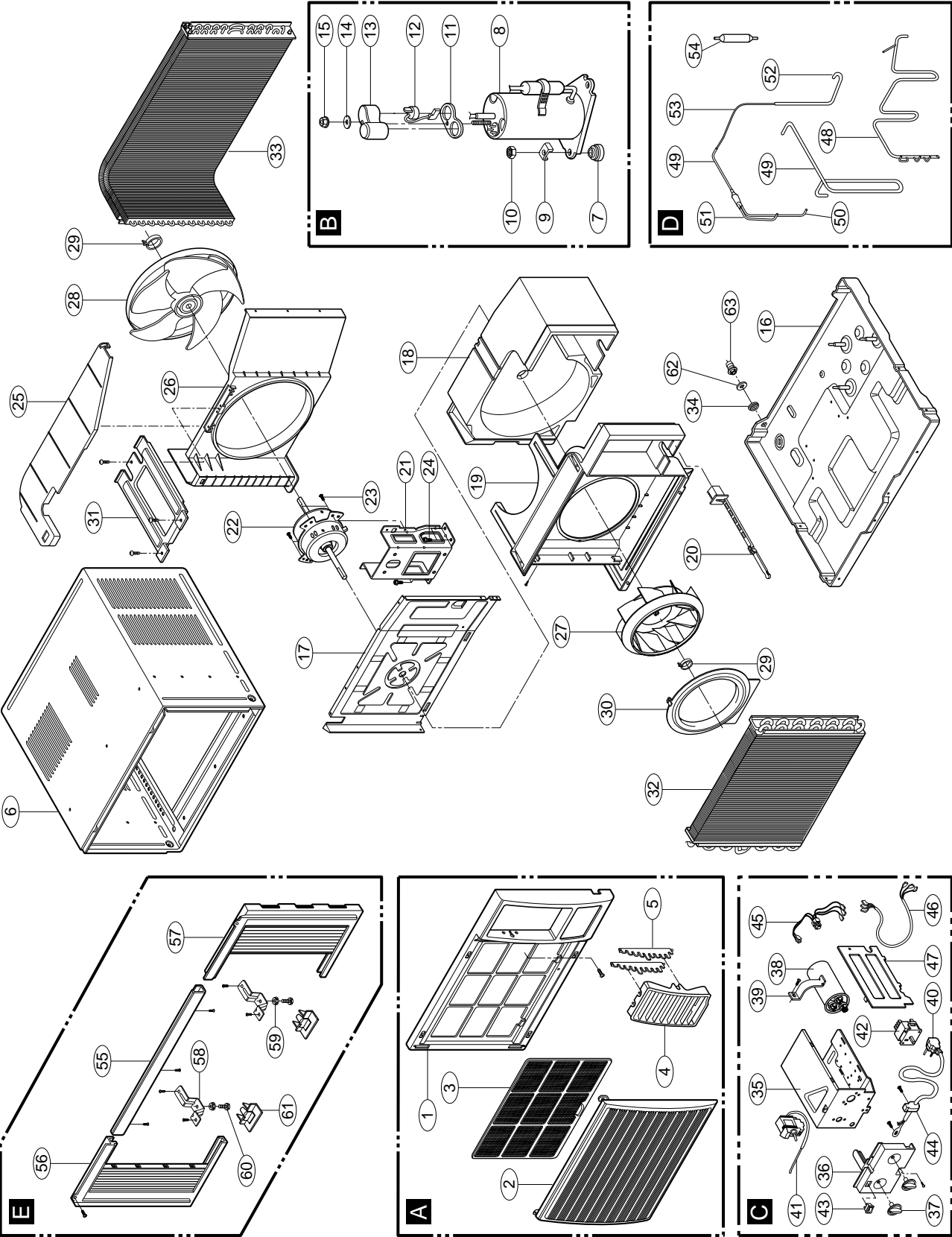

7. REPLACEMENT PARTS LIST

• MODEL: ZQ10A10B

LOCATION NO.	FRIEDRICH PART NO.	DESCRIPTION	PART NO.	Q'TY PER SET	REMARK
			ZQ10A10B		
A	673-060-02	FRONT GRILLE ASSY	3531A20034C	1	R
1	673-044-02	FRONT GRILLE	3530A10026A	1	R
2	673-061-01	INLET GRILLE	3530A10028A	1	R
3	673-043-02	AIR FILTER ASSY	5231A20004A	1	R
4	673-062-01	LOUVER, HORIZONTAL	4758A20002A	1	R
5	673-062-50	VERTICAL LOUVER	4758A30008A	2	R
6	673-037-03	CABINET ASSY	3091A30005C	1	R
B		COMP & ACCESSORY ASSY			
7		ANTI-VIBRATION BUSH	4830AR4335A	3	R
8		COMPRESSOR	2520UKLC2CA	1	R
9	673-018-00	BRACKET, WASHER	4810AR4155B	3	N
10	673-017-00	HEXAGON NUTS	1NHA0801206	3	N
11		GASKET	4986U-L001G	1	R
12		OVERLOAD PROTECTOR	6750U-L031A	1	R
13		TERMINAL COVER	3550U-L006A	1	R
14	673-011-00	GASKET-NUT	4H01058A	1	R
15	673-010-00	NUT, TERMINAL COVER	4H00947A	1	R
16		BASE PAN WELD ASSY	3041A30005P	1	R
17	673-068-00	BARRIER, SINGLE	4790A10008A	1	R
18		SCROLL	3072A20004A	1	R
19		AIR GUIDE	5238A10006A	1	R
20	673-035-02	VENTILATION DAMPER	4901A30001A	1	R
21		MOTOR MOUNT	4960A20014A	1	R
22		MOTOR ASSY	4681A20027J	1	R
23	673-069-01	SCREW	4000W4A003A	2	N
24	673-069-00	SCREW, TAP	4H00006D	4	N
25		COVER, COND.	3550A30064A	1	R
26		SHROUD	4998A10010A	1	R
27		FAN, TURBO	5900A20016A	1	R
28		FAN	5900A20015A	1	R
29	673-025-00	CLAMP SPRING	3H02932B	2	R
30		ORIFICE	4948A30007A	1	R
31	673-039-01	BRACE	4800A30001A	1	R
32		EVAPORATOR ASSY	5421A20061F	1	R
33		CONDENSER ASSY	5403A20043B	1	R
34	673-071-00	RUBBER	4H02023A	1	R

LOCATION NO.	FRIEDRICH PART NO.	DESCRIPTION	PART NO.	Q'TY PER SET	REMARK
			ZQ10A10B		
C		CONTROL BOX ASSY	4995A20118N	1	R
35	673-054-01	CONTROL BOX, SINGLE	4994A10006B	1	R
36	673-055-01	CONTROL PANEL ASSY	3721A20037B	1	R
37	673-041-03	KNOB ASSY	4941A30011A	2	R
38		CAPACITOR	0CZZ20001V	1	R
39	673-006-00	CAPACITOR CLAMP	4H00442N	1	R
40		POWER CORD ASSY	2H00677R	1	R
41	673-004-02	THERMOSTAT	2H01109L	1	R
42	673-005-01	ROTARY SWITCH	2H00598E	1	R
43	673-057-01	ROCKER SWITCH	2H01316C	1	R
44		CLIP CORD	4H01762A	1	R
45	673-003-62	LEAD WIRE ASSY	6631AR2687A	1	R
46		CONDUCT ASSY	6631AR3843P	1	R
47		COVER, CONTROL BOX	3550A30036B	1	R
D		PIPE			
48		SUCTION TUBE ASSY	5211A20130R	1	R
49		DISCHARGE TUBE	5211AR2930Z	1	R
50		TUBE EVAPORATOR	5210A21847A	1	R
51		TUBE EVAPORATOR	5210A20847B	1	R
52		TUBE ASSY, CONNECTOR	5211AR7059Y	1	R
53		CAPILLARY	5211A20598B	1	R
54		DRIER ASSY	5851A30001F	1	R
E	673-063-03	INSTALL PART ASSY	3127AR3403M	1	R
55	673-040-02	UPPER GUIDE	5210AR3196F	1	R
56	673-038-02	CURTAIN ASSY	4959AR3402A	1	R
57	673-038-03	CURTAIN ASSY	4959AR3402B	1	R
58	673-065-00	BRACKET, ANGLE	4810AR3240A	2	R
59	673-067-00	NUT, HEXAGON	1NHC1000006	2	R
60	673-066-00	BOLT	1BHD1004006	2	R
61	673-064-00	FRAME GUIDE	3210AR3337A	2	R
62	673-069-02	WASHER, PLAIN	4H01029D	1	R
63	673-070-00	DRAIN, PIPE	3H02773A	1	R

Use Factory Certified Parts...



FRIEDRICH AIR CONDITIONING CO.
Visit our web site at www.friedrich.com

Post Office Box 1540 • 4200 N. Pan Am Expressway • San Antonio, Texas 78295-1540
• (210) 357-4400 • FAX (210) 357-4480

P/NO.: 3828A20038V

Printed in the U.S.A

ZQ10 (03/01)