

This Owner's Manual is provided and hosted by [Appliance Factory Parts](#).

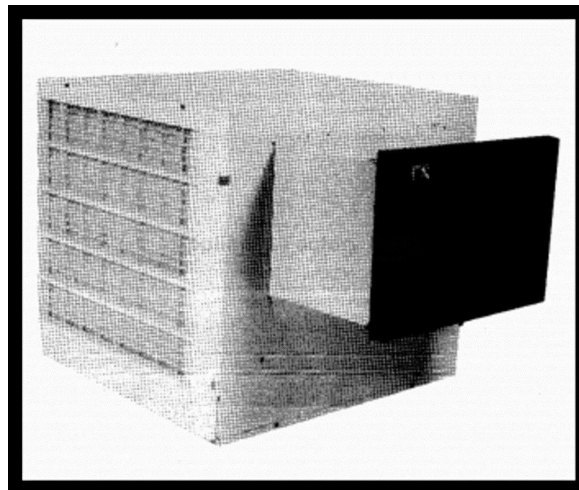

Kenmore 661.626020 Owner's Manual

[Shop genuine replacement parts for Kenmore
661.626020](#)



[Find Your Kenmore Air Conditioner Parts - Select From 261 Models](#)

----- Manual continues below -----

SEARS

owners
manual

MODEL NO.
661.624921
661.626020
661.626920

**READ
AND
SAVE
THIS
INSTRUCTION
MANUAL**

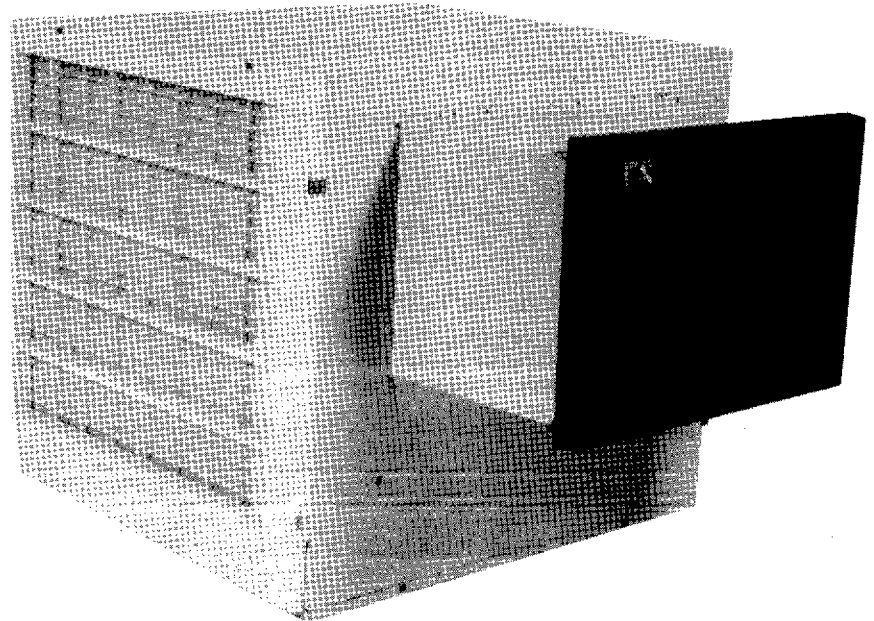

Kenmore WINDOW TYPE EVAPORATIVE AIR COOLER

- Installation
- Operation
- Repair Parts

SEARS, ROEBUCK AND CO., Chicago, IL 60684 U.S.A.

CONTENTS

INSTALLATION AND OPERATION

Tools and Supplies You Will Need	3
Adjusting Cooler for Your Window	3
Mounting Cooler in Window	4-5
Installation Accessories	6
Startup Checklist, Cooling Information	7-8
Specifications	8
How to Operate	8

COOLER CARE

Spring, Summer and Fall Care	9
Cleaning	9
Replacing Pads	10
Oiling	10
Belt Adjustment	10

REPAIR PARTS	11-12
---------------------------	-------

INTRODUCTION

Your air cooler uses a new design for evaporating water to cool air. The low energy use of conventional evaporative air coolers is combined with new water handling methods and materials which help overcome most rust problems of conventional coolers. The compact size and modern appearance allow easy installation.

Please read our instructions before you install and use your new cooler. This will help you obtain the full benefits from your cooler and will also help you avoid any needless service costs that result from causes we cannot control and cannot cover in our warranty.

FULL ONE YEAR WARRANTY ON SEARS EVAPORATIVE COOLER

One year from the date of purchase, when this Kenmore Roto-Belt evaporative air cooler is installed and maintained according to our instructions, Sears will repair defects in material or workmanship free of charge.

FIVE YEAR LIMITED WARRANTY

All Sears Kenmore Roto-Belt cooler cabinets and blower housings are warranted against rusting out and becoming inoperative after one year and through five (5) years from the date of purchase. Sears Roto-Belt cooler water reservoirs and louvers are warranted also against leaking and deterioration due to water corrosion for the same period of time. You pay for labor.

WARRANTY SERVICE IS AVAILABLE BY SIMPLY CONTACTING THE NEAREST SEARS SERVICE CENTER THROUGHOUT THE UNITED STATES.

This warranty gives you specific legal rights, and you may also have other rights which vary from state to state.

SEARS, ROEBUCK AND CO., DEPT. 698/731A, SEARS TOWER, CHICAGO, IL 60684

Note: Replacement of filter pads is normal maintenance and is not covered in the warranty.

To function properly, your cooler must be installed correctly. You must know how to use tools and equipment. If you have any doubt, we suggest that you contact your Sears salesperson who will arrange for a prompt, quality installation by Sears authorized installers.

SEARS INSTALLATION WARRANTY

In addition to any warranty extended to you on the Sears merchandise involved, which warranty becomes effective the date the merchandise is installed, should the workmanship of any Sears arranged installation prove faulty within one year, Sears will, upon notice from you, cause such faults to be corrected at no additional cost to you.

SEARS INSTALLATION POLICY

All installation labor arranged by Sears shall be performed in a neat, workmanlike manner in accordance with generally accepted trade practices. Further, all installations shall comply with all local laws, codes, regulations and ordinances. The customer shall also be protected, during installation, by insurance relating to property damage, Workmen's Compensation and Public Liability.

NEED ADVICE? MISSING PARTS? - CALL MANUFACTURER FIRST:

Just dial this toll free number **1-800-643-2742** to get facts fast:

Call Monday through Friday 8:00 A.M. to 5:00 P.M. - Central Time

Our experienced Hotline Service Representative can:

- Answer installation questions.
- Provide prompt shipment of missing parts.

YOUR SATISFACTION IS OUR NUMBER ONE PRIORITY

Reminder: The person you will be talking to is **Not** a **SEARS** store employee and cannot handle exchanges, arrange service calls etc.. This must be handled through your Sears Store or Catalog Order Department. This toll-free number is for **technical assistance only**.

INSTALLATION

TOOLS AND SUPPLIES YOU WILL NEED

Pliers	Electric Drill
Adjustable Wrenches	Drill Bits, 1/8", 3/16"
Screwdrivers	* Water Connection Kit
Tubing Cutter	Level
5/16 inch nut driver	* See page 6

NOTE: You may change the cooler air duct to fit sliding or narrow windows. The following instructions are ONLY FOR CHANGING THE DUCT POSITION.

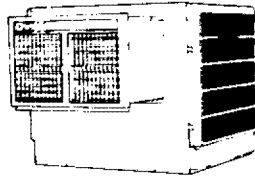

NORMAL POSITION

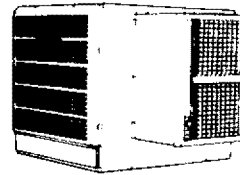

POSITION FOR NARROW WINDOWS

FIGURE 6

CHANGING DUCT TO VERTICAL POSITION for narrow windows (Figure 7)

1. Turn the cooler so that the duct points up.
2. Remove screws around the duct mounting flange.
3. Use the foam tape included in the parts envelope. Remove the backing.
4. Put the tape on the duct flange which will be on top.
5. Turn the duct to vertical position and line up the screw holes.
6. Securely fasten the duct with screws removed in step 2.
7. See narrow window installation instructions on page 5.

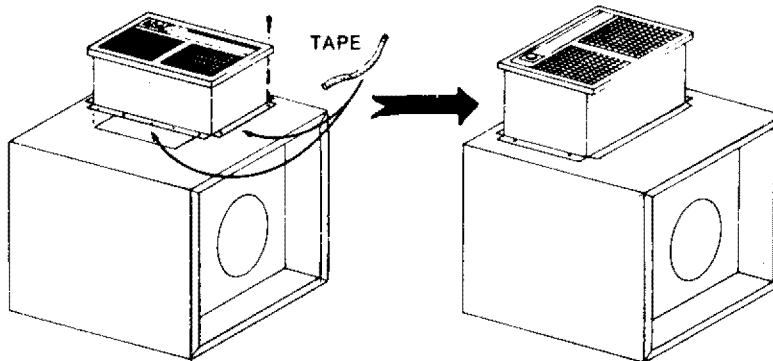

FIGURE 7

DETERMINE YOUR WINDOW TYPE

Your window opening must be at least 23 inches by 17 inches.

For narrow windows you may need to change the duct position as described above.

For narrow window installations see page 5.

For regular window installations see page 4.

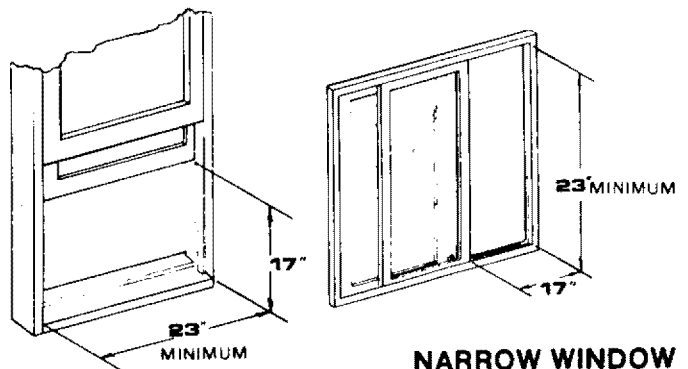

NARROW WINDOW

INSTALLATION

PREPARE WINDOW (Figure 1)

1. Mark four screw locations on the sill. Drill 1/8 inch pilot holes about 1/2 inch deep at each mark.
2. Fasten each bracket (furnished) with 2 #8 x 5/8 inch screws found in the parts bag.

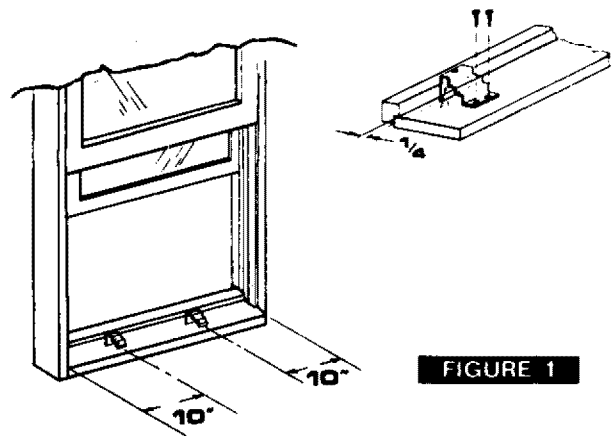

FIGURE 1

INSTALL COOLER (Figure 2)

3. Take the two outside louvers off the cooler. Page 9 shows how. Set the louvers where they will not fall.
4. Raise the cooler to window level and hook the duct over the sill brackets. Hold up the cooler cabinet with a temporary stand during installation.
5. Put a nut on each support rod. Insert the rods into the cabinet holes. The nut must be on the outside of the cabinet.
6. Turn the support rod adjustment nuts until the rod ends touch the wall.
7. Put rod ends into brackets. Be sure rods are level. Mark bracket screw holes on wall. Remove cooler from window and drill 1/8" pilot holes. Attach each bracket to your wall with 4 each #8 x 5/8" screws.
8. Install cooler (Step 5). Put rod ends into brackets. TURN ADJUSTMENT NUTS TO LEVEL COOLER.
9. Lower the inside window sash until it is in back of the angle bracket.
10. Fasten a stop above the inside sash to stop the window from being raised. IF THE WINDOW IS RAISED THE COOLER MAY FALL!

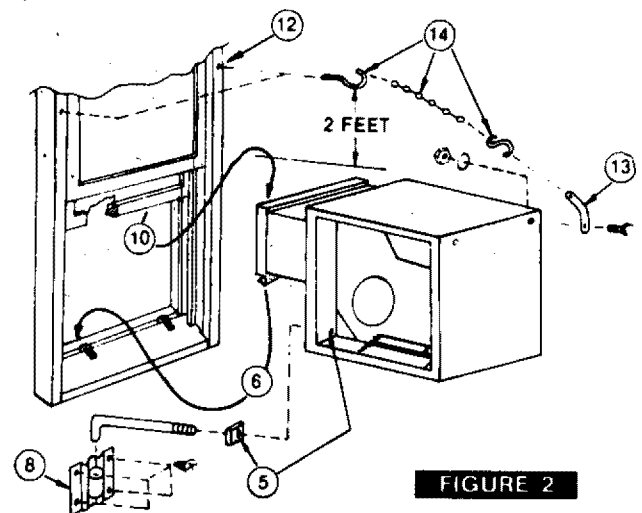

FIGURE 2

The following instructions are for use with the chain kit 32-61000.

11. Drill 3/16 inch pilot holes in window frame. Screw hooks in to full thread depth.
12. Fasten straps to cooler cabinet. Use 5/16 x 5/8 screws, lockwashers and nuts. Tighten securely.
13. Attach the chains and S hooks. Adjust until each chain is tight.

PUT PANELS IN WINDOW (Figure 3)

14. Put in the left panel first. See figure 3.
15. Measure between the duct side and the window frame.
16. Mark the measured distance (from 15) on the panel measured from the step. Break the panel on the first break line past the mark.
17. Put the notched panel edge into the slot behind the grille frame. The notch fits around the cord.
18. Put in the right panel in the same way.

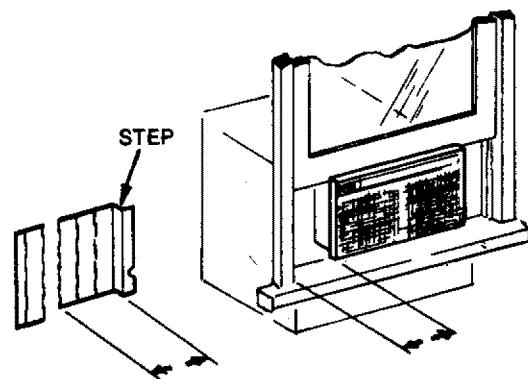

FIGURE 3

INSTALLATION

NARROW WINDOW INSTALLATION

(Figure 4)

1. If window between 14 inches and 16 1/2 inches wide, you must remove both duct flanges. Reattach flanges to duct after it is put through window.
2. Take the two outside louvers off the cooler. Page 9 shows how. Set the louvers where they will not fall.
3. Raise the cooler to window level and place the duct flanges against window and window frame. Install spacer between the duct flange and window as required. Hold up the cooler with a temporary stand during installation.
4. Put a nut on each support rod. Insert the rods into the cabinet holes. The nuts must be on the outside of the cabinet. (Figure 6)
5. Turn support rod adjustment nuts until rod ends touch the wall.
6. Put rod ends into brackets. Be sure rods are level. Mark bracket screw holes on wall. Remove cooler from window and drill 1/8" pilot holes. Attach each bracket to wall with 4 each #8 x 5/8" screws.

Install cooler (Step 3). Put rod ends into brackets. **TURN ADJUSTMENT NUTS TO LEVEL COOLER.**

7. Fasten a stop block next to the duct to prevent the duct from shifting and unhooking from the window frame (Figure 5). **IF THE DUCT UNHOOKS THE COOLER MAY FALL.**
8. **TURN ADJUSTMENT NUTS TO LEVEL THE COOLER.** (Figure 6, Key 5)

NOTE: If you do not fasten the cooler to the window frame as below, support the cooler on a stand made to fit your installation.

The following instructions are for use with the chain kit 32-61000.

9. Drill 3/16 inch pilot holes in window frame. Screw hooks in to full thread depth.
10. Fasten straps to cooler cabinet. Use 5/16 x 5/8 screw, lockwasher and nut. Tighten securely.
11. Attach chains and S hooks. Adjust until chain is tight.
12. Fill open space with glass in a removable frame to fit the window frame above the cooler.

THROUGH THE WALL INSTALLATION

With the duct changed to the vertical position, the cooler can be installed through a wall between existing interior wall studs (without cutting studs). Plan the work carefully so that interior water pipes and wiring won't be disturbed. Make sure installation complies with local codes.

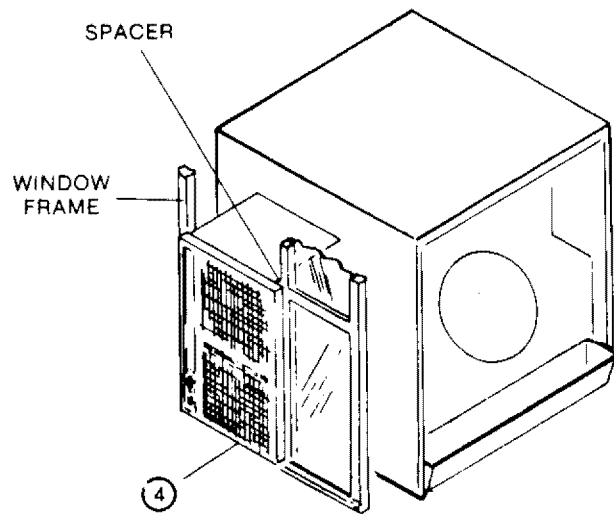

FIGURE 4

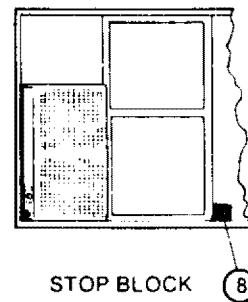

FIGURE 5

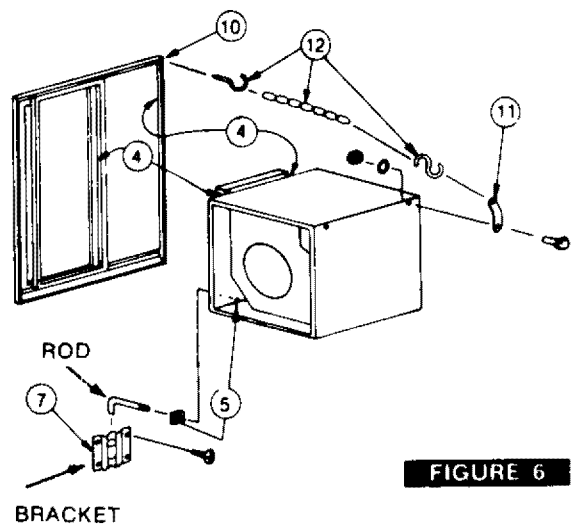

FIGURE 6

INSTALLATION

FINAL ASSEMBLY & ADJUSTMENT

PUT FLOAT VALVE IN COOLER

Put the float valve through the spout hole and cabinet hole. Tighten the ring nut. Be sure the float moves straight up and down. **TURN THE FLOAT UNTIL A NARROW SIDE IS UP.** Snap the splash guard cover into the water spout as shown. The water spout and splash guard cover are provided to prevent water from "spurting" and splashing outside the water reservoir.

CONNECT WATER LINE

Use Kit 32-62527 Copper Water Hook Up Kit - 25' of 1/4" Copper Tubing plus a Brass Outdoor Faucet Adapter (Fig. 8). Kit 32-62528 is the same as above, but use plastic tubing instead of copper.

To hook up to a cold Pipe, use 32-62522 Saddle Valve and 32-62551 for 25' of 1/4" Copper Tubing or 32-62552 for 50' of Copper Tubing (Fig. 7) **RUN WATER TO CLEAR LINE BEFORE CONNECTING TO COOLER.** Install line to Float Valve.

PUT IN WATER DRAIN KIT (Fig. 9)

- Push the BUSHING through the washer and into the water reservoir hole. Tighten the ring nut onto the bottom. Screw the overflow pipe into the bushing and tighten to prevent leaks. Repeat for the second reservoir.

ADJUST WATER LEVEL

- Turn on the water. Check the water level when the float valve shuts off. If the water level is above the mark on the water tray, bend the float rod down; if the level is too low, bend the rod up.

WARNING: TO REDUCE THE RISK OF FIRE OR ELECTRIC SHOCK, DO NOT USE THIS FAN WITH ANY SOLID-STATE SPEED CONTROL DEVICE.

START UP CHECKLIST

Before turning on your cooler check the following:

1. Duct is securely fastened to the window frame.
2. Cooler is level, front to back and side to side.
3. Water supply is turned on and line fittings do not leak.
4. Float valve is adjusted for proper water level. See page 6.
5. Belt tension is correct. See page 10.
6. Evaporative pads are correctly installed. See page 10.
7. Pad motors are plugged into receptacles. See page 9.
8. All louver clips are snapped tight. See page 9.

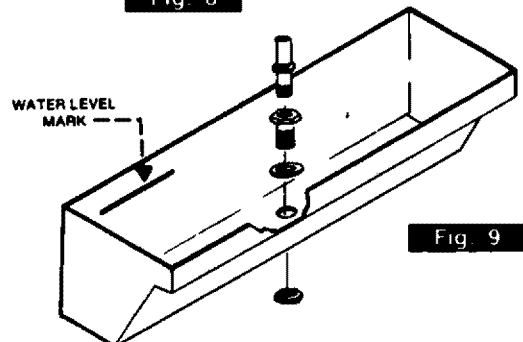
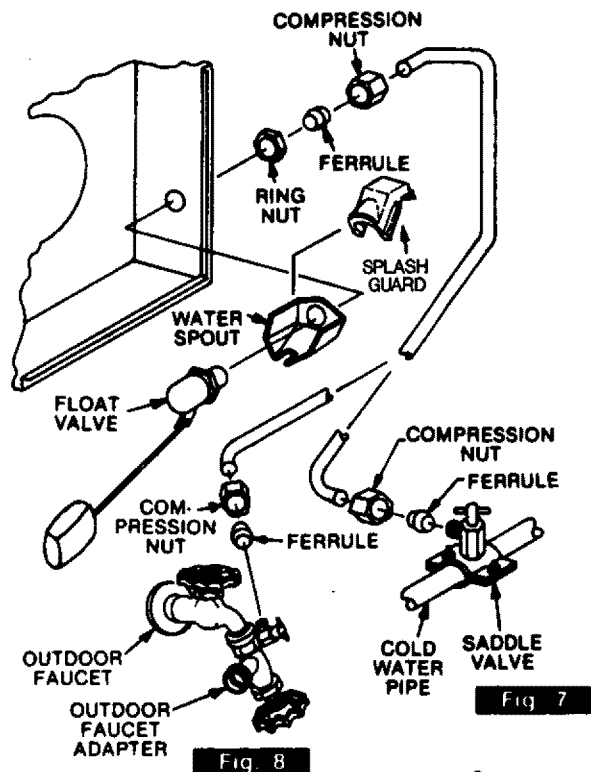

9. Model 661.626020, 661.626920 requires a 15 ampere time delay fuse in the fuse box.
10. Open windows, doors and vents to let out the hot house air.
Model 661.624921 requires 5 to 6 square feet of openings.
Model 661.626020 requires 7 to 8 square feet of openings.
Model 661.626920 requires 9 to 10 square feet of openings.
11. Check out operations. Both pads moved in maximum cool high and low switch positions. (Only one pad moves in minimum cool high or low. Models 661.624921, 661.626020, 661.626920.)

HOW TO USE YOUR COOLER

HOW YOUR COOLER WORKS (Figure 10)

Your cooler evaporates water to cool air. Evaporative air cooling is the same natural cooling that happens when a breeze springs up after a summer shower. You feel cool because the rain water evaporates and carries away heat.

Your new design cooler has a motor (1) driven blower (2) which draws outside air through pads (3) which are turned by drive motors (4). The pads revolve in water reservoirs (5) filled through float valve (6) and water crossover pipe (7). The cooled air enters your home through the inside grille (8).

If the output air is too cold you may switch this cooler from "Maximum Cool" to "Minimum Cool"

Then only one pad will turn, reducing the cooling effect. You may also run the cooler in "Vent" position when you want fresh air but no cooling.

Relative humidity affects the cooling capacity of any cooler. See chart to determine the maximum amount of cooling possible at your outside temperature and outside humidity (Figure 11).

COOLING YOUR HOME (Figure 12)

Your cooler and windows or vents are the two parts of your air cooling system. Outside air is filtered and cooled, goes through your home, and carries away heat and many household odors. You control the air cooling flow to your rooms by opening doors, windows, or vents.

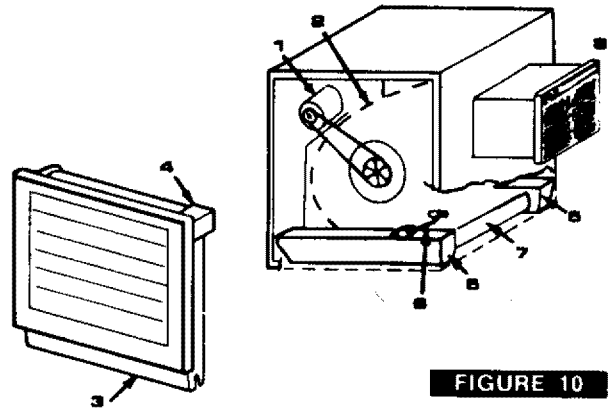

FIGURE 10

OUTSIDE TEMPERATURE	OUTSIDE RELATIVE HUMIDITY - %							
	5	10	15	20	30	40	50	60
80°	56°	58°	60°	61°	64°	67°	69°	72°
90°	62°	64°	66°	68°	72°	75°	78°	81°
100°	68°	71°	73°	75°	79°	83°	87°	90°
110°	74°	77°	80°	82°	87°	92°	95°	—
120°	79°	83°	86°	95°	100°	—	—	—

COOLEST POSSIBLE OUTPUT TEMPERATURE OF COOLER

FIGURE 11

You must have window, door, or vent openings to let air out when the cooler runs. The total opening areas you need follow:

MODEL	TOTAL OPENING AREA
661.624921	5 square feet minimum area
661.626020	7 square feet minimum area
661.626920	9 square feet minimum area

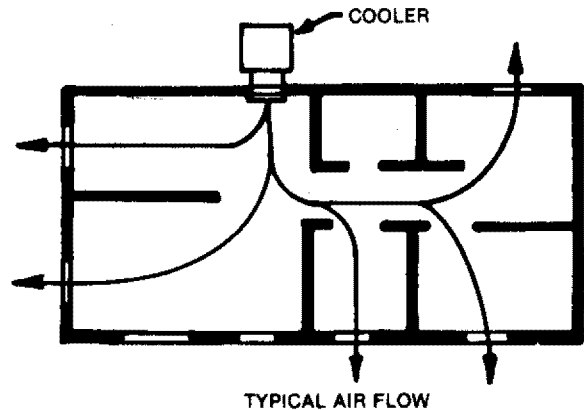

TYPICAL AIR FLOW

FIGURE 12

HOW TO USE YOUR COOLER

COOLER CONTROL USE

MODEL 661.624921, 661.626020, 661.626920

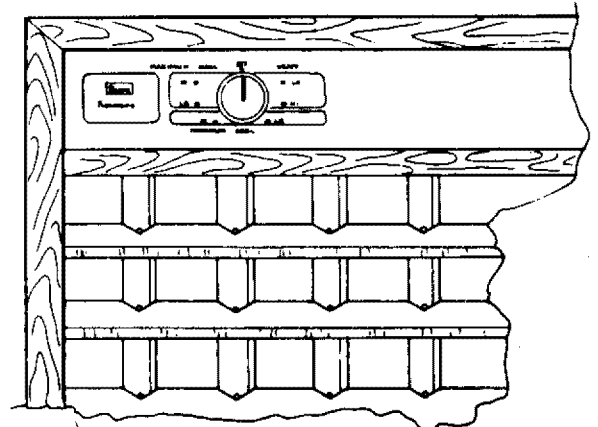
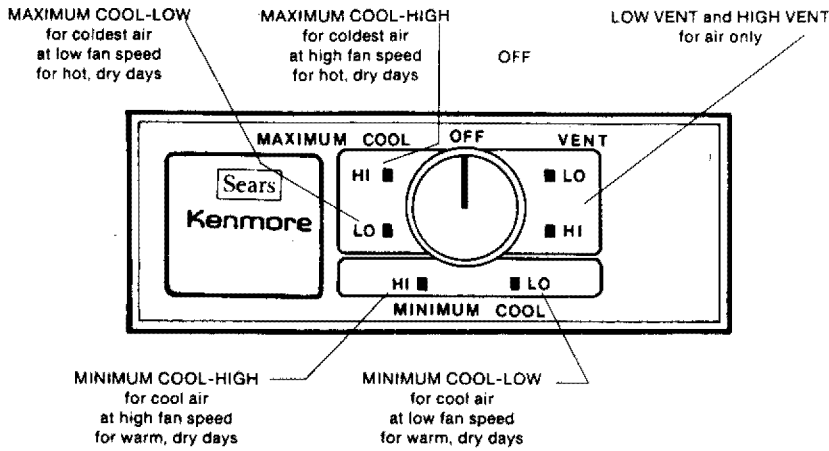

The grille fins are adjustable up and down and left and right.

SPECIFICATIONS

Model Number	624921	626020	626920
Output cubic feet per minute industry rating (High/Low)	4300/2900	4700/3100	5600/3400
Weight, pounds dry	122	161	161
with water	156	215	215
Volts, 60HZ (cycles)	120	120	120
Sears Pad No.	32-6290	32-6293	32-6293

WIRING DIAGRAM

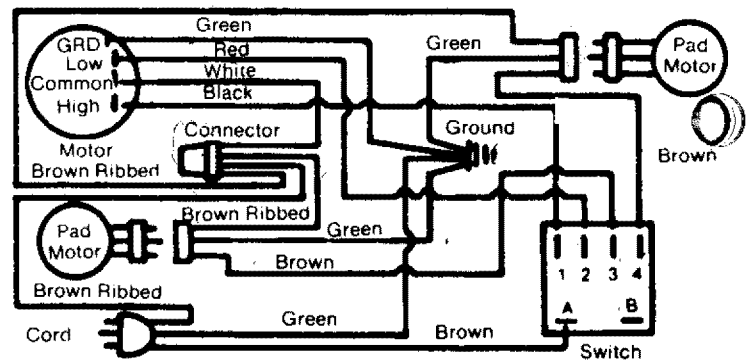

MODELS 661.624921, 661.626020, 661.626920

FLOAT VALVE INSTALLATION INSTRUCTIONS

It is of the Utmost Importance that the Float Valve, Splash Guard and Splash Guard Cover be installed exactly as described in the illustration below.

- 1) The Float Valve-Must be installed with the narrow side of the float in the vertical position. If not installed this way the float will hang up and cause the reservoir drain pipes to overflow.
- 2) The water Spout and Water Spout Cover are provided to prevent water from "spurting" and splashing outside of the reservoirs. Snap in the Splash Guard Cover as illustrated below.

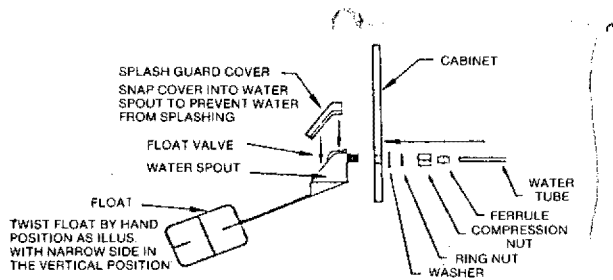

INSTALLATION OF OUTSIDE ROLLERS

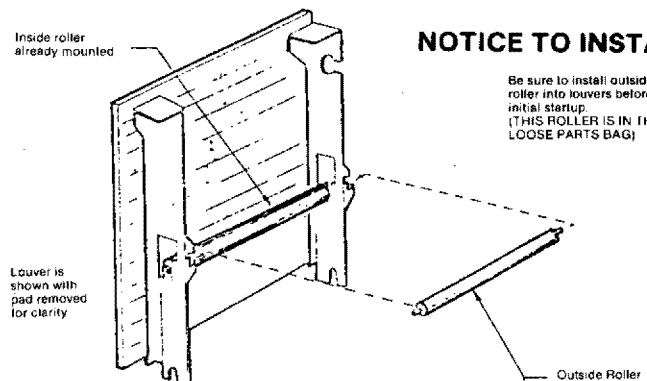

NOTICE TO INSTALLERS

Be sure to install outside roller into louvers before initial startup. (THIS ROLLER IS IN THE LOOSE PARTS BAG)

CARE OF YOUR COOLER

CAUTION: ALWAYS UNPLUG YOUR COOLER BEFORE YOU WORK ON IT. YOU COULD BE HURT IF THE COOLER IS TURNED ON WHEN YOUR HANDS ARE INSIDE THE COOLER.

SPRING CARE:

Oil your cooler.

Put a new pad in if the old pad is plugged with dirt or water hardness.

CAUTION:
Disconnect the power supply to the cooler before attempting to install, open or service your cooler.



OPERATION OF ROTO-BELT COOLERS IN "HARD WATER" AREAS

1. Clean the cooler frequently.
2. Remove mineral build-up from water troughs and Roto Belts to prevent clogging.
3. A water analysis will determine: Mineral Content, what water treatments can be used, what cleaning agents should be used.
4. A "Bleed-Off" kit (32-62562) should be installed to help keep mineral build up to a minimum.

CLEANING YOUR COOLER

WARNING: NEVER WASH YOUR COOLER INTERIOR WITH A GARDEN HOSE. WATER MAY HARM THE MOTOR OR GET INTO YOUR HOUSE.

1. Unsnap the six louver clips. Use a small screwdriver. See Fig. 13.
2. Unplug the pad motor and remove the louver.
3. Connect a garden hose to the water tray drain fitting.
4. Unscrew and remove the overflow pipe to drain the tray.
5. Take off the pad if it is dirty or plugged with hard water deposits.
6. Use a sponge and mild detergent to wash the dirt and scale from the water tray and louver. **DO NOT GET WATER ON THE PAD MOTOR!**
7. If the pads are plugged with hard water deposits and dirt, replace the pads.
8. Replace the overflow pipe and louver.

Note: Sears has an automatic Bleed-off System (32-62562) for your Roto Belt® cooler. It will help keep the water in the reservoirs clean and increase pad life.

SUMMER CARE:

Drain and clean your cooler every two months if your water is hard or the air is dusty.

You may prolong pad life in many hard water areas if you drain the water tray every two to three weeks.

FALL CARE:

Drain the cooler and water line to prevent frost damage.

Cover the cooler or take it out of the window.

Sears has covers to fit your cooler.

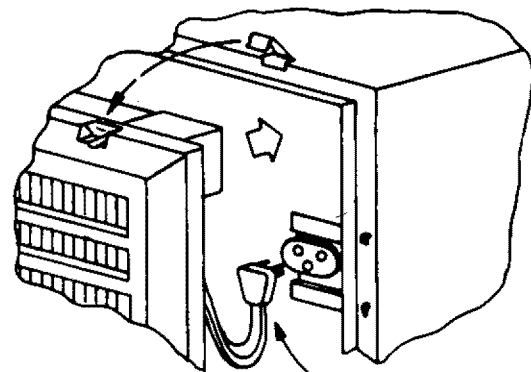

FIGURE 13

PAD MOTOR PLUG

WARNING: To Reduce The Risk Of Fire Or Electric Shock, Do Not Use This Fan With Any Solid-State Speed Control Device.

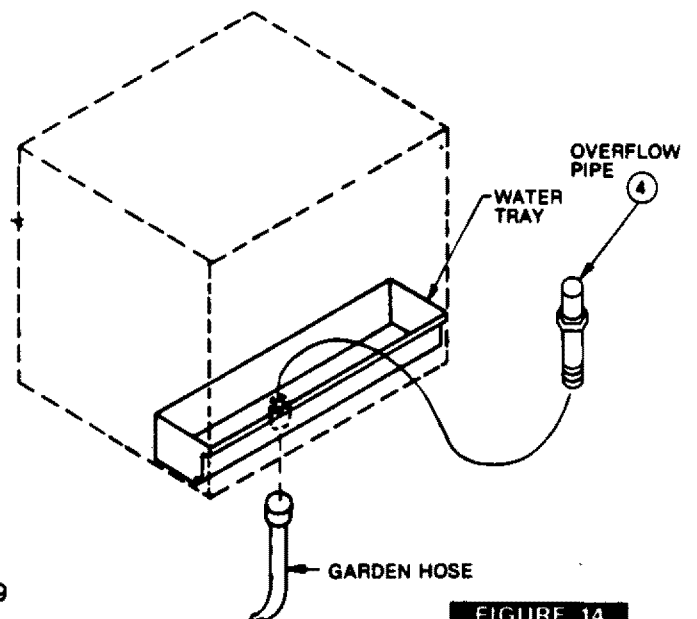

FIGURE 14

CARE OF YOUR COOLER

REPLACING THE PAD

1. Lift up the small roller ends to unsnap the two center rollers.
2. Pull out and turn the top roller bearing arm to line up the slot.
3. Pull out the top roller end.
4. Remove and discard the pad.
5. Put the lower roller in the new pad.
6. Fit the lower roller into the louver frame slots.
7. Push the top roller through the pad. Fit the roller end over the pad motor shaft drive block.
8. Push the top roller end into the bearing.
9. Turn the bearing arm to hold the roller in place.
10. Tuck the pad edges under the 2 guides on each side.
11. Put the two small center rollers in place. Snap the small roller ends into the holders.

MODEL NUMBER	SEARS PAD NUMBER
661.624921	32-6290
661.626020	32-6293
661.626920	32-6293

OILING YOUR COOLER

Use SAE 20 non-detergent motor oil. Oil your cooler once a year.

1. Put 3 or 4 drops in the end bearing on each pad motor.
2. Put 2 or 3 drops in each oil fill tube on the blower motor, unless motor is permanently lubricated, in which case it will not have oil tubes.
3. Fill the oil filler on each blower bearing.

BLOWER BELT ADJUSTMENT

1. If you can easily move the belt side to side over 1 inch, it needs adjustment.
2. To adjust belt tension loosen the 3 motor mount bolts.
3. Push motor to tighten belt until it moves about 1/2 inch up with finger force.
4. Tighten 3 motor mount bolts.

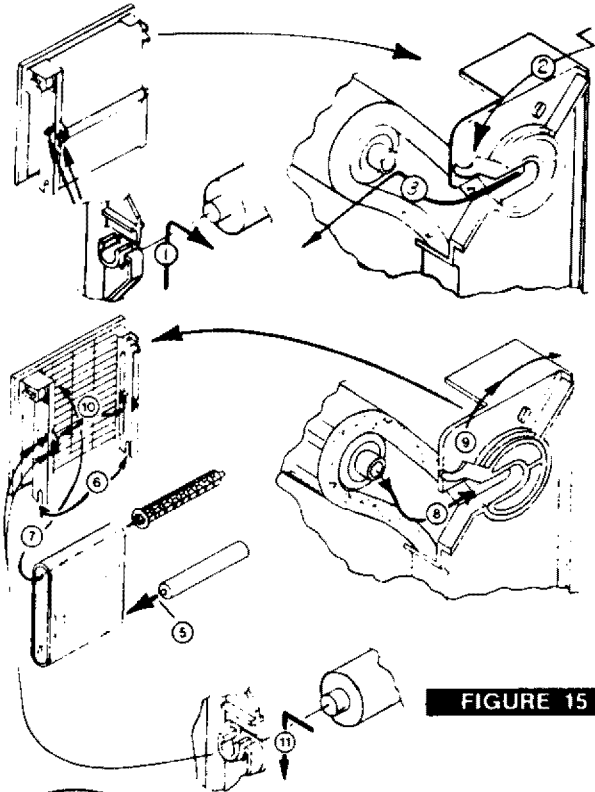

FIGURE 15

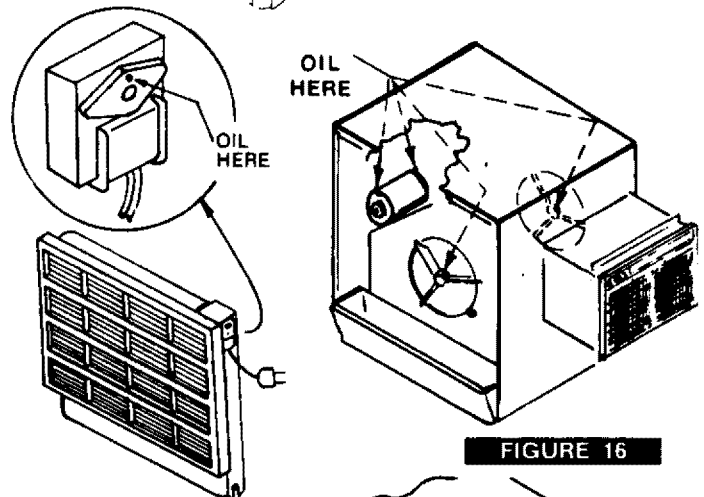

FIGURE 16

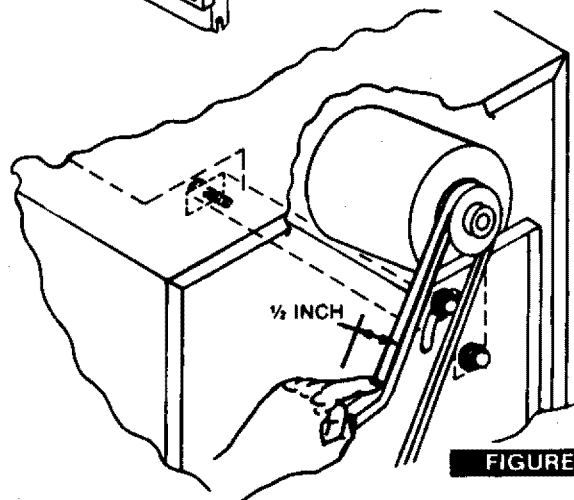
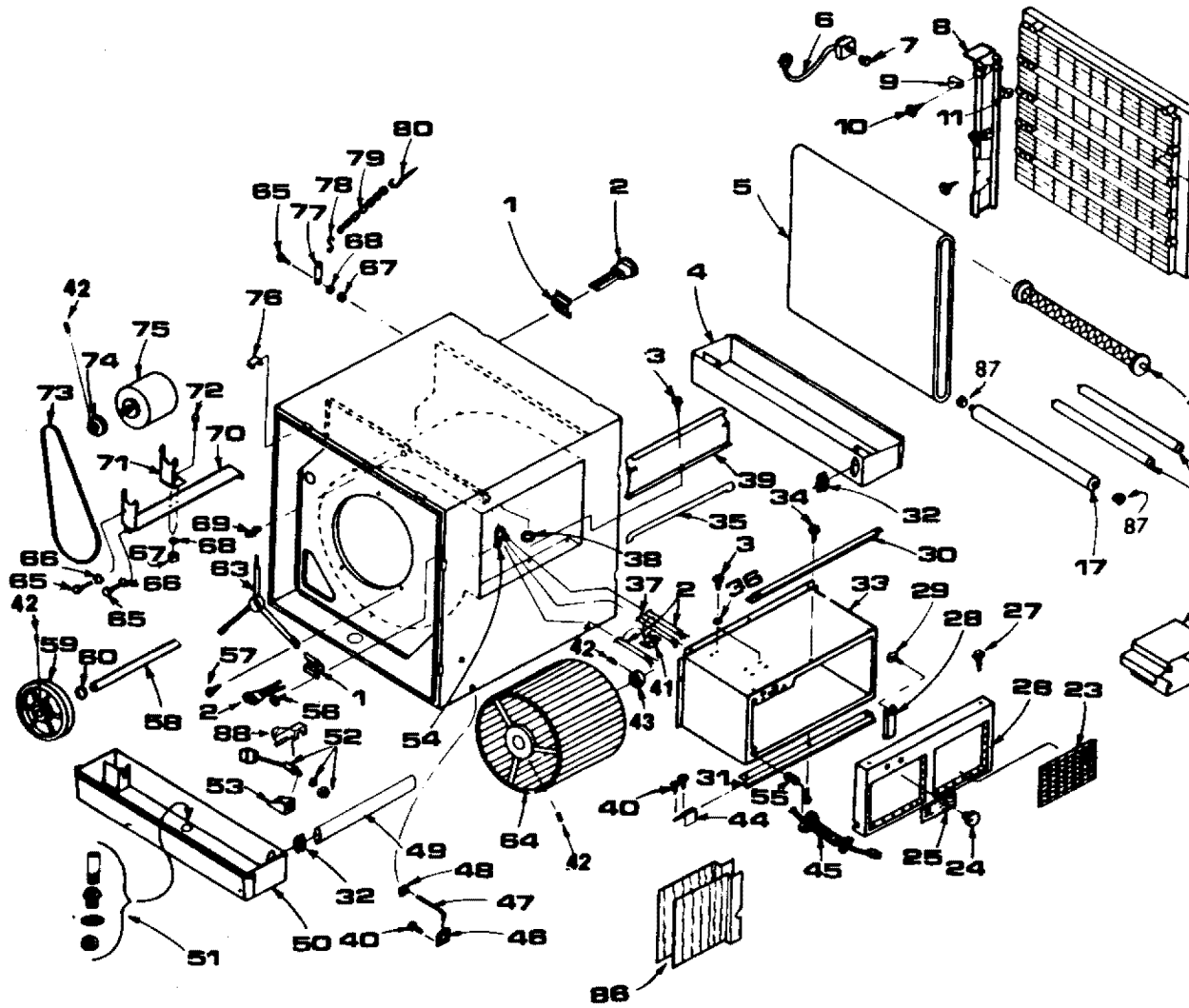

FIGURE 17

KENMORE WINDOW TYPE EVAPORATIVE AIR COOLER
MODEL 661.624921, 661.626020, 661.626920



**REPAIR PARTS KENMORE WINDOW TYPE EVAPORATIVE AIR COOLER
MODEL NOS. 661-624921, and 661.626020 and 661.626920**

NOTICE: Order by PART NUMBER, not by Key number. Refer to information below for parts ordering information.

KEY NO.	PART NO. FOR MODEL NO.		PART DESCRIPTION	KEY NO.	PART NOS. FOR MODEL NO.		PART DESCRIPTION
	624921	626020/626920			624921	626020/626920	
1.	30311-00	30311-00	Receptacle Mount - (2 Req.)	44.	30572	30572	Step Bracket - (2 Req.)
2.	30876	30543	Pad Motor Connector	45.	31501	31501	Cord. Electric (7'10" long)
3.	STD610805	STD610805	Screw Hex. Hd. Ty B#8 X 1/2	46.	30160	30160	Wall Bracket - (2 Req.)
4.	32013-10	32019-10	Reservoir	47.	30161	30161	Support Rod - (2 Req.)
5.	32-6290	32-6293	Evaporator Pad - (2 Req.)	48.	05494	05494	Nut Sq. 10-24
6.	32-6298	32-6298	Motor (2 Req.)	49.	31985-01	31985-03	Tube
7.	29862	29862	Roller Drive - (2 Req.)	50.	32013-20	32019-20	Reservoir
8.	30297-01	30233-01	Support, Motor Side	51.	31086	31086	Drain Overflow
9.	14201	14201	Clamp	52.	30482	30482	Float Valve
10.	30465	30465	Screw Hex. Hd. Ty BT # 10 x 3/8	53.	30418-01	30418-01	Water Shield
11.	STD511103	STD51103	Screw Pan Hd 10-32 X 3/8	54.	30525	30525	Clamp
12.	29931-01	30214-01	Louver	55.	30462	30462	Bushing
13.	31047	31047	Bearing (2 Req.)	56.	STD610803	STD610803	Screw Pan Hd. Ty AB # 8 x 3/8
14.	30296-01	30206-01	Side Support (2 Req.)	57.	08133	08133	Screw Hex Hd. Ty B 1/4-20 X 3/8
15.	30248-01	30224-01	Drive Roller (2 Req.)	58.	30241	30238-02	Shaft
16.	30234	30211	Roller (4 Req.)	59.	50124	583091/583099	Pulley (includes Key 42)
17.	30236	30212	Bottom Roller (2 Req.)	60.	501244	501241	Washer, Leather
18.	50222	50222	Switch Cover	63.	30287	30289	Bearing Mount
19.	30488	30488	Switch				
20.	14982	14982	#8 Star Lockwasher				
21.	30585	30585	Screw Hex. Hd. Ty T 8- 32 x 7/16	64.	30318	30322	Blower Wheel
22.	14863	14863	Nut Hex. 3/8 - 24	65.	30551	30551	Screw Hex Hd. 5/16-18 3/8
23.	29169	29169	Louver (2 Req.)	66.	STD551137	STD551137	Lockwasher 3/8
24.	30564	30564	Knob	67.	STD541031	STD541031	Nut 5/16-18
25.	30706	30706	Nameplate	68.	STD551131	STD551131	Lockwasher 5/16
26.	50429	50429	Frame	69.	14864	14864	Bushing
27.	STD610905	STD610805	Screw Hex. Hd. Ty AB #8 x 1/2	70.	30306	30305	Motor Mount
28.	30524	30524	Channel	71.	50255	50255	Tail Mount
29.	24391	24391	Screw Hex. Hd. Ty B 8 x 7/16	72.	STD523107	STD523107	Screw Hex Hd. 5/16-18- x 3/4
30.	30172-01	30172-01	Flange, Duct Top	73.	30558	30560/582006	V-Belt
31.	30173-01	30173-01	Flange, Duct Bottom	74.	31085	16579	Pulley (includes Key 42)
32.	31984	31984	Grommet	75.	32-61073	32-61074/61075	Motor
33.	30513-01	30512-01	Duct	76.	30105	30105	Clip (12 Req.)
34.	STD611005	STD611005	Screw Hex. Hd. Ty AB #10 x 1/2	77.	30565	30565	Strap
35.	30848	30848	Gasket	78.	30567	30567	S-Hook
36.	18741	18741	Washer, Rubber	79.	30566	30566	Chain
37.	30539	30882	Switch Cord	80.	30568	30568	Screw Hook
38.	29816	29816	Bushing	81.	30339	30338	Louver Assembly (Keys 5-17)
39.	30208	30177	Baffle				
40.	STD610807	STD610807	Screw Pan Hd. Ty AB #8 x 3/4	83.	32-6230	32-6230	Grille Cover (2 Req.)
41.	30529	30529	Strain Relief	*	32-62562	32-62562	Bleed Kit Optional
42.	STD503105	STD503105	Set Screw - 5/16 - 18 x 1/2	*	522216	522216	Owners Manual - F642-1089
43.	501280	501243	Hex Socket	86.	30569	30569	Side Panels
			Collar	87.	24971-1	24971-1	Bushing - Bottom Roller
				88.	523122	523122	Splash Guard Cover
				*	32-6201	32-6202	Winter Cooler Cover

* Not Shown

Model Numbers 661.624921
661.626020
661.626920

The Model Number of your Evaporative Air Cooler will be found on the cooler cabinet label.

How to Order Repair Parts

All parts listed herein may be ordered from any SEARS ROEBUCK AND CO. service center.

WHEN ORDERING REPAIR PARTS ALWAYS GIVE THE FOLLOWING INFORMATION:

1. PART NUMBER (SEE REPAIR PARTS)
2. PART DESCRIPTION (SEE REPAIR PARTS)
3. MODEL NUMBER
4. NAME OF ITEM (EVAPORATIVE COOLER)

If the parts you need are not stocked locally, your order will be electronically transmitted to a Sears Repair Parts Distribution Center for handling.