

This Owner's Manual is provided and hosted by [Appliance Factory Parts](#).



# FRIEDRICH UE08A13A Owner's Manual

[Shop genuine replacement parts for FRIEDRICH  
UE08A13A](#)



[Find Your FRIEDRICH Air Conditioner Parts - Select From 1575 Models](#)

----- Manual continues below -----

# **Friedrich®**

## **Thru-the-Wall Series Service and Parts Manual**

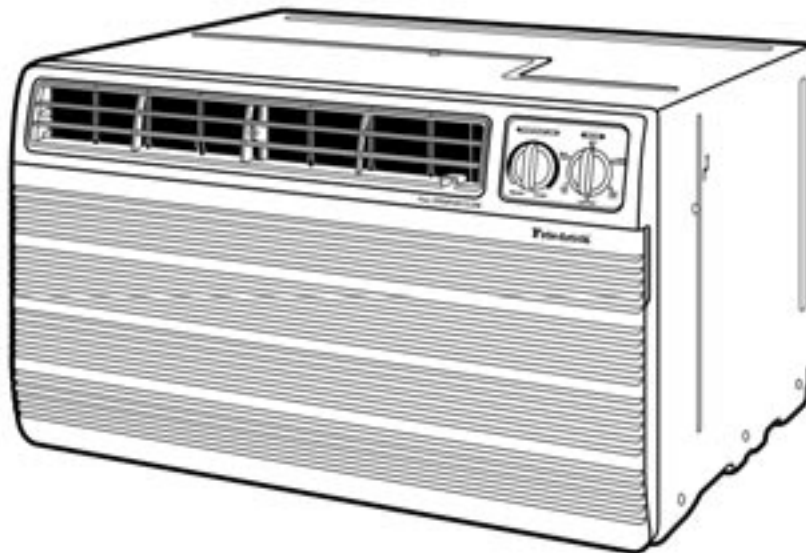

## **Thru-the-Wall Series**

**115 Volts • UE08A13A • US08A10A • US10A10A • US12A10A  
230 Volts • US10A30A • UE10A33A • US12A30A • UE12A33A**

# CONTENTS

## 1. PREFACE

1.1 SAFETY PRECAUTIONS .....	2
1.2 INSULATION RESISTANCE TEST.....	2
1.3 SPECIFICATIONS .....	3
1.4 FEATURES .....	6
1.5 CONTROL LOCATIONS.....	6

## 2. DISASSEMBLY INSTRUCTIONS

2.1 MECHANICAL PARTS.....	8
2.1.1 FRONT GRILLE .....	8
2.1.2 CABINET.....	8
2.1.3 CONTROL BOX .....	8
2.2 AIR HANDLING PARTS.....	9
2.2.1 ORIFICE, HEATER ASSY AND TURBO FAN .....	9
2.2.2 FAN.....	9
2.2.3 SHROUD.....	10
2.3 ELECTRICAL PARTS .....	10
2.3.1 MOTOR.....	10
2.3.2 COMPRESSOR .....	10
2.3.3 CAPACITOR .....	10
2.3.4 POWER CORD .....	11
2.3.5 THERMOSTAT .....	11
2.3.6 ROTARY SWITCH.....	11

2.4 REFRIGERATION CYCLE.....	12
2.4.1 CONDENSER .....	12
2.4.2 EVAPORATOR .....	12
2.4.3 CAPELLARY TUBE.....	12

## 3. INSTALLATION

3.1 INSTALLATION REQUIREMENTS.....	15
3.2 INSTALLATION.....	16
3.3 PROCEDURE A.....	17
3.4 PROCEDURE B.....	18
3.5 PROCEDURE C.....	20
3.4 ELECTRICAL REQUIREMENTS .....	22
3.4.1 ELECTRICAL DATA(FOR 115V MODEL) .....	22
3.4.2 ELECTRICAL DATA(FOR 230V/208 MODEL) .....	22
3.4.3 ELECTRICAL SAFETY .....	22

## 4. TROUBLESHOOTING GUIDE

4.1 OUTSIDE DIMENSIONS.....	23
4.2 PIPING SYSTEM .....	23
4.3 TROUBLESHOOTING GUIDE.....	24

## 5. SCHEMATIC DIAGRAM

5.1 CIRCUIT DIAGRAM.....	29
--------------------------	----

## 6. EXPLODED VIEW .....

## 7. REPLACEMENT PARTS LIST .....

## 1. PREFACE

This SERVICE MANUAL provides various service information, including the mechanical and electrical parts etc. This room air conditioner was manufactured and assembled under a strict quality control system. The refrigerant is charged at the factory. Be sure to read the safety precautions prior to servicing the unit.

### 1.1 SAFETY PRECAUTIONS

1. When servicing the unit, set the ROTARY SWITCH or POWER SWITCH to OFF(O) and unplug the power cord.
2. Observe the original lead dress.  
If a short circuit is found, replace all parts which have been overheated or damaged by the short circuit.
3. After servicing the unit, make an insulation resistance test to protect the customer from being exposed to shock hazards.

### 1.2 INSULATION RESISTANCE TEST

1. Unplug the power cord and connect a jumper between 2 pins (black and white).
2. The grounding conductor (green or green & yellow) is to be open.
3. Measure the resistance value with an ohm meter between the jumpered lead and each exposed metallic part on the equipment at all the positions (except OFF or O) of the ROTARY SWITCH.
4. The value should be over 1MΩ.

## 1.3 SPECIFICATIONS

### 1.3.1 FOR US08A10A/ US10A10A/ US12A10A

ITEMS		MODELS			REMARK
		US08A10A	US10A10A	US12A10A	
POWER SUPPLY		1Ø, 115V, 60Hz			
COOLING CAPACITY (Btu/h)		8,000	10,000	11,700	
INPUT (W)		800	1,050	1,230	
RUNNING CURRENT (A)		7.5	9.8	11.5	
E.E.R (Btu/w.h)		10.0	9.5	9.5	
REFRIGERANT (R-22) CHARGE(g)		425(15.0 OZ)	410(14.5 OZ)	475(16.8 OZ)	
OPERATING TEMPERATURE	INDOOR (°C)	26.7(DB) 19.4(WB)			
	OUTDOOR (°C)	35(DB) 23.9(WB)			
EVAPORATOR		2 ROW 12 STACKS		2 ROW 11 STACKS	LOUVERED-FIN TYPE
CONDENSER		2 ROW 17 STACKS, L-BENDED TYPE			
FAN, INDOOR		TURBO FAN			
FAN, OUTDOOR		PROPELLER TYPE FAN WITH SLINGER-RING			
FAN SPEEDS, FAN/COOLING		2/3			
FAN MOTOR		6 POLES			
OPERATION CONTROL		ROTARY SWITCH			
ROOM TEMP. CONTROL		THERMOSTAT			
AIR DIRECTION CONTROL		VERTICAL LOUVER(RIGHT & LEFT)			
		HORIZONTAL LOUVER(UP & DOWN)			
CONSTRUCTION		TOP-DOWN			
PROTECTOR	COMPRESSOR	EXTERNAL OVERLOAD PROTECTOR			
	FAN MOTOR	INTERNAL THERMAL PROTECTOR			
POWER CORD		1.6m (3WIRE WITH GROUNDING)			
		ATTACHMENT PLUG(CORD-CONNECTED TYPE)			
DRAIN SYSTEM		SPLASHED BY FAN SLINGER			
NET WEIGHT (lbs/kg)		72/33	79/36	80/37	
DIMENSION (W x H x D)		(inch)	24 <sup>21/32</sup> x 14 <sup>13/32</sup> x 19 <sup>21/32</sup>		
		(mm)	626 x 366 x 499		
SLEEVE DIMENSION (W x H x D)		(inch)	25 <sup>7/8</sup> x 15 <sup>17/32</sup> x 16 <sup>23/32</sup>		OPTIONAL PART
		(mm)	656 x 394 x 425		
SLEEVE DEPTH WITH FRONT GRILLE		(inch)	20		
		(mm)	510		

### 1.3.2 FOR US10A30A/US12A30A

ITEMS		MODELS		REMARK
		US10A30	US12A30	
POWER SUPPLY		1Ø, 208/ 230V, 60Hz		
COOLING CAPACITY	(Btu/h)	9,800/10,000	11,400/11,700	
INPUT	(W)	1,030/1,050	1,200/1,230	
RUNNING CURRENT	(A)	5.2/4.7	6.2/5.8	
E.E.R.	(Btu/W.h)	9.5	9.5	
OPERATING TEMPERA-TURE	INDOOR (°C)	26.7 (DB)	19.4 (WB)	
	OUTDOOR (°C)	35 (DB)	23.9 (WB)	
REFRIGERANT (R-22) CHARGE(g)		440(15.5 OZ)	465(16.4 OZ)	
EVAPORATOR		2 ROW 12 STACKS	2 ROW 11 STACKS	LOUVERED-FIN TYPE
CONDENSER		2 ROW 17 STACKS, L-BENDED TYPE		
FAN, INDOOR		TURBO FAN		
FAN, OUTDOOR		PROPELLER TYPE FAN WITH SLINGER-RING		
FAN SPEEDS (FAN/COOLING/HEATING)		2/3		
FAN MOTOR		6 POLES		
OPERATION CONTROL		ROTARY SWITCH		
ROOM TEMP. CONTROL		THERMOSTAT		
AIR DIRECTION CONTROL		VERTICAL LOUVER (RIGHT & LEFT)		
		HORIZONTAL LOUVER (UP & DOWN)		
CONSTRUCTION		TOP-DOWN		
PROTECTOR	COMPRESSOR	EXTERNAL OVERLOAD PROTECTOR		
	FAN MOTOR	INTERANL THERMAL PROTECTOR		
POWER CORD		1.6m (3 WIRE WITH GROUDING)		
		ATTACHMENT PLUG (CORD-CONNECTED TYPE)		
DRAIN SYSTEM		SPLASHED BY FAN SLINGER		
NET WEIGHT	(lbs/kg)	80/36	80/37	
DIMENSION (W x H x D)	(inch)	24 <sup>21/32</sup> x 14 <sup>13/32</sup> x 19 <sup>21/32</sup>		
	(mm)	626 x 366 x 499		
SLEEVE DIMESION (W x H x D)	(inch)	25 <sup>7/8</sup> x 15 <sup>17/32</sup> x 16 <sup>23/32</sup>		OPTIONAL PART
	(mm)	656 x 394 x 425		
SLEEVE DEPTH WITH FRONT GRILLE	(inch)	20		
	(mm)	510		

### 1.3.3 FOR UE08A13B/UE10A33B/UE12A33B

ITEMS		MODELS	UE08A13B	UE10A33B	UE12A33B	REMARK
POWER SUPPLY			1Ø, 115V, 60Hz	1Ø, 208/ 230V, 60Hz		
COOLING	CAPACITY (Btu/h)		8,000	9,800/10,000	11,400/11,700	
	INPUT (W)		830	1,040/1,060	1,210/1,250	
	RUNNING CURRENT (A)		7.5	5.2/4.7	6.2/5.8	
	E.E.R. (Btu/W.h)		9.6	9.4	9.4	
HEATING	CAPACITY (Btu/h)		3,850	9,200/11,200		
	INPUT (W)		1,230	2,900/3,500		
	RUNNING CURRENT (A)		10.7	14.0/15.3		
OPERATING TEMPERATURE	COOLING	INDOOR (°C)	26.7 (DB) 19.4 (WB)			
		OUTDOOR (°C)	35 (DB) 23.9 (WB)			
	HEATING	INDOOR (°C)	21.1 (DB) 15.6 (WB)			
		OUTDOOR (°C)	8.3 (DB) 6.1 (WB)			
REFRIGERANT (R-22) CHARGE(g)			425(15.0 OZ)	440(15.5 OZ)	465(16.4 OZ)	
EVAPORATOR			2 ROW 12 STACKS		2 ROW 11 STACKS	LOUVERED-FIN TYPE
CONDENSER			2 ROW 17 STACKS, L-BENDED TYPE			
FAN, INDOOR			TURBO FAN			
FAN, OUTDOOR			PROPELLER TYPE FAN WITH SLINGER-RING			
FAN SPEEDS (FAN/COOLING/HEATING)			1/ 2/ 2			
FAN MOTOR			6 POLES			
OPERATION CONTROL			ROTARY SWITCH			
ROOM TEMP. CONTROL			THERMOSTAT			
AIR DIRECTION CONTROL			VERTICAL LOUVER (RIGHT & LEFT)			
			HORIZONTAL LOUVER (UP & DOWN)			
CONSTRUCTION			TOP-DOWN			
ELECTRIC HEATER			1.2KW, 115V	3.5KW, 208/230V		
PROTECTOR	COMPRESSOR		EXTERNAL OVERLOAD PROTECTOR			
	FAN MOTOR		INTERANL THERMAL PROTECTOR			
	ELECTRIC HEATER		FUZE LINK, BIMETAL THERMOSTAT			
POWER CORD			1.6m (3 WIRE WITH GROUDING)			
			ATTACHMENT PLUG (CORD-CONNECTED TYPE)			
DRAIN SYSTEM			SPLASHED BY FAN SLINGER			
NET WEIGHT (lbs/kg)			73/33	80/36	81/37	
DIMENSION (W x H x D)		(inch)	24 <sup>21</sup> / <sub>32</sub> x 14 <sup>13</sup> / <sub>32</sub> x 19 <sup>21</sup> / <sub>32</sub>			
		(mm)	626 x 366 x 499			
SLEEVE DIMESION (W x H x D)		(inch)	25 <sup>7</sup> / <sub>8</sub> x 15 <sup>17</sup> / <sub>32</sub> x 16 <sup>23</sup> / <sub>32</sub>			OPTIONAL PART
		(mm)	656 x 394 x 425			
SLEEVE DEPTH WITH FRONT GRILLE		(inch)	20			
		(mm)	510			

## 1.4 FEATURES

- Designed for cooling only.
- Powerful and quiet cooling.
- Top-down chassis for the simple installation and service.
- Side air-intake, side cooled-air discharge.
- Built in adjustable THERMOSTAT.
- Washable one-touch filter.
- Compact size.

## 1.5 CONTROL LOCATIONS

### 1.5.1 COOLING ONLY MODEL

#### • OPERATION

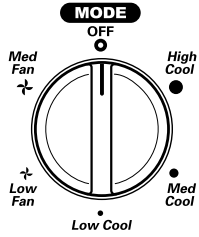
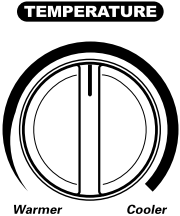
 <p>The diagram shows a circular knob with a vertical slot. The top position is labeled 'OFF'. Moving clockwise from 'OFF', the positions are: 'Med Fan Only', 'High Cool', 'Med Cool', and 'Low Cool'. Moving counter-clockwise from 'OFF', the positions are: 'Low Fan Only' and 'Med Fan'.</p>	<p>Off - Turns air conditioner off.</p> <p>Med Fan Only - Med speed fan operation without cooling.</p> <p>Low Fan Only - Low speed fan operation without cooling.</p> <p>High Cool - Cooling with high speed fan operation.</p> <p>Med Cool - Cooling with med speed fan operation.</p> <p>Low Cool - Cooling with low speed fan operation.</p>
 <p>The diagram shows a circular knob with a vertical slot. The left side is labeled 'Warmer' and the right side is labeled 'Cooler'.</p>	<p>This automatically controls the temperature of the indoor air.</p> <p>Turn the knob clockwise for greater cooling.</p> <p>Turn the knob counter-clockwise for more moderate cooling.</p>

#### • VENTILATION

Push the lever to the "CLOSE" position to cool, heat or recirculate room air only.

Pull the lever to the "OPEN" position to exhaust smoke or stale air from the room.

This feature is best used in conjunction with the FAN ONLY position.

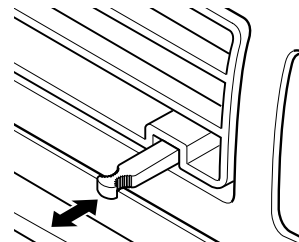

**PULL OPEN / PUSH CLOSE**

## 1.5.2 COOLING AND HEATING MODEL

### • OPERATION

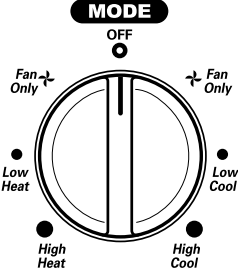
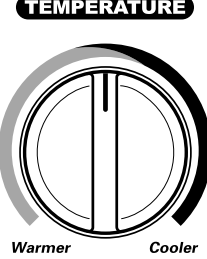
 <p>The diagram shows a circular MODE knob with a vertical line through the center. At the top is 'OFF'. Moving clockwise from the top, the settings are: 'Fan Only' (two positions), 'Low Cool', 'High Cool', 'Low Heat', and 'High Heat'.</p>	<p>Off - Turns the air conditioner off.          Fan Only - The low fan speed operation without cooling (heating).          Low Cool - Cooling with the low speed fan operation.          High Cool - Cooling with the high speed fan operation.          Low Heat - Heating with the low speed fan operation.          High Heat - Heating with the high speed fan operation.</p>
 <p>The diagram shows a circular TEMPERATURE knob with a vertical line through the center. A curved arrow on the left indicates the 'Warmer' direction (counter-clockwise), and a curved arrow on the right indicates the 'Cooler' direction (clockwise).</p>	<p>Turn the Temperature Knob to the desired setting. The central position is a normal setting for average conditions. You can change this setting, if necessary, in accordance with your temperature preference.</p> <p>The thermostat automatically controls cooling or heating, but the fan runs continuously whenever the air conditioner is in operation. If the room is too warm, turn the thermostat control clockwise. If the room is too cool, turn the thermostat control counterclockwise.</p>

### CAUTION

When the air conditioner has been operated in the cooling or heating mode and is turned off or set to the fan position, wait at least 3 minutes before resetting to the cooling operation again.

A slight burning odor may come from the unit when first switching to HEAT after the cooling season is over. This odor, caused by fine dust particles on the heater, will disappear quickly. This is normal operation.

## 2. DISASSEMBLY INSTRUCTIONS

— Before the following disassembly, POWER SWITCH is set to OFF and disconnected the power cord.

### 2.1 MECHANICAL PARTS

#### 2.1.1 FRONT GRILLE

1. Open the inlet grille upward or downward.
2. Remove the screw which fastens the front grille.
3. Pull the front grille from the right side.
4. Remove the front grille. (See Fig. 1)
5. Re-install the component by referring to the removal procedure.

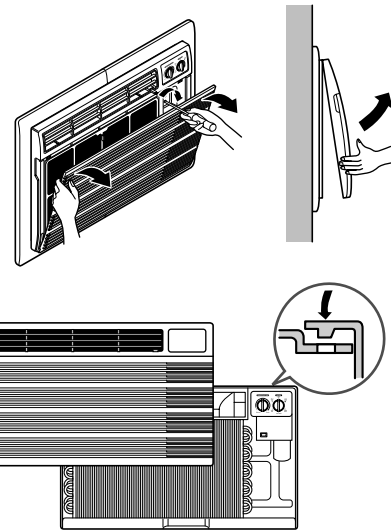

Figure 1

#### 2.1.2 CABINET

1. After disassembling the FRONT GRILLE, remove the 9 screws which fasten the cabinet at the both sides and the top. (See Fig. 2)  
Keep these for later use.

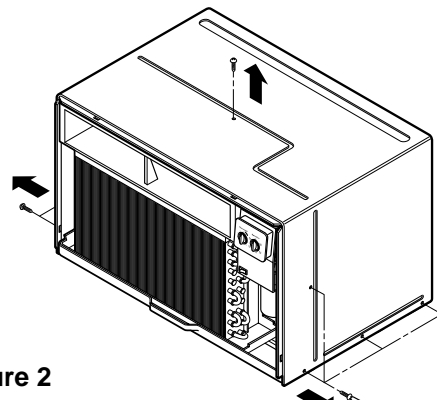

Figure 2

#### 2.1.3 CONTROL BOX

1. Remove the front grille. (Refer to section 2.1.1)
2. Remove the screw which fasten the control box. (See Fig. 3)
3. Pull the control box from the barrier. (See Fig. 3)
4. Discharge the capacitor by placing a 20,000 ohm resistor across the capacitor terminals.
5. Disconnect two wire housings in the control box.
6. Pull the control box forward completely.
7. Re-install the components by referring to the removal procedure. (See Fig. 3)  
(Refer to the circuit diagram found on pages 26~27 in this manual and on the control box.)

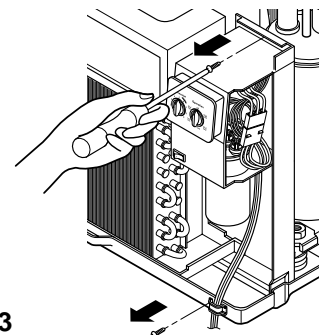

Figure 3

## 2.2 AIR HANDLING PARTS

### 2.2.1 ORIFICE, HEATER ASSY AND TURBO FAN

1. Remove the front grille. (Refer to section 2.1.1)
2. Remove the cabinet. (Refer to section 2.1.2)
3. Remove the 2 screws which fasten the evaporator at the left side and the right side. (See Fig. 4)
4. Move the evaporator sideward carefully.
5. Remove the 2 terminals carefully (See Fig. 5, at Electric Heater Model only)
6. Remove the 4 screws which fasten the orifice. (See Fig. 5)
7. Remove the orifice. (See Fig. 5)

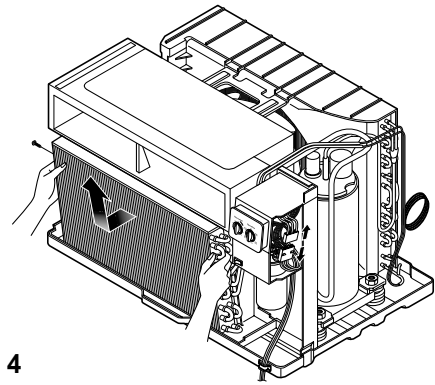

Figure 4

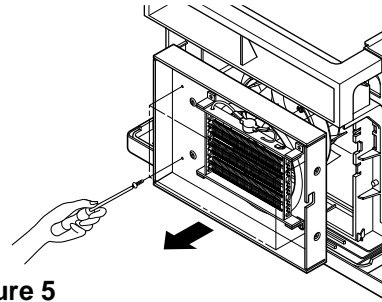

Figure 5

8. Remove the clamp which secures the turbo fan with plier. (See Fig. 6)

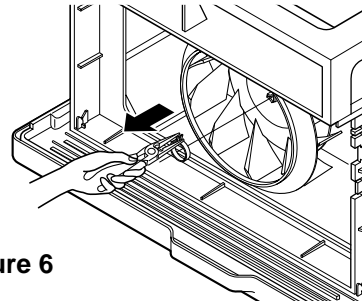

Figure 6

9. Remove the turbo fan with plier or your hand without touching blades. (See Fig. 7)
10. Re-install the components by referring to the removal procedure, above.

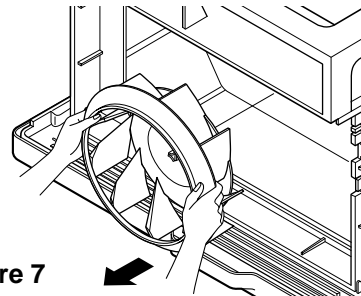

Figure 7

### 2.2.2 FAN

1. Remove the cabinet. (Refer to section 2.1.2)
2. Remove the brace and shroud cover. (Refer to section 2.2.1)
3. Remove the 6 screws which fasten the condenser.
4. Move the condenser sideways carefully.
5. Remove the clamp which secures the fan.
6. Remove the fan. (See Fig. 8)
7. Re-install the components by referring to the removal procedure, above.

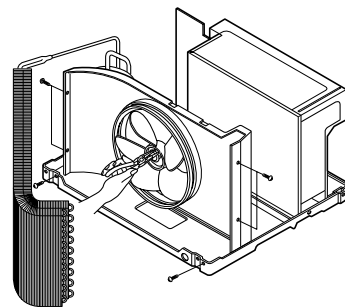

Figure 8

### 2.2.3 SHROUD

1. Remove the fan. (Refer to section 2.2.2)
2. Remove the screw which fasten the shroud.
3. Remove the shroud. (See Fig. 9)
4. Re-install the component by referring to the removal procedure, above.

## 2.3 ELECTRICAL PARTS

### 2.3.1 MOTOR

1. Remove the cabinet. (Refer to section 2.1.2)
2. Remove the clamp cord and disconnect a wire housing in control box. (Refer to section 2.1.3)
3. Remove the turbo fan. (Refer to section 2.2.2)
4. Remove the fan. (Refer to section 2.2.2)
5. Remove the 4 or 2 screws which fasten the motor. (See Fig. 10)
6. Remove the motor.
7. Re-install the components by referring to the removal procedure, above.

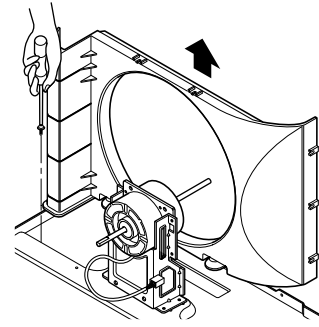

Figure 9

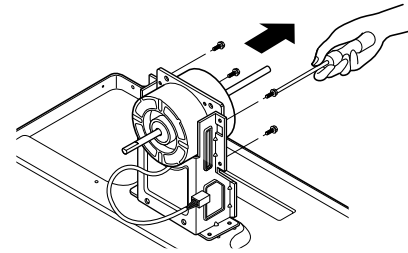

Figure 10

### 2.3.2 COMPRESSOR

1. Remove the cabinet. (Refer to section 2.1.2)
2. Discharge the refrigerant system using Freon™ Recovery System.  
If there is no valve to attach the recovery system, install one (such as a WATCO A-1) before venting the Freon™. Leave the valve in place after servicing the system.
3. Disconnect the 3 leads from the compressor.
4. After purging the unit completely, unbraid the suction and discharge tubes at the compressor connections.
5. Remove the 3 nuts and the 3 washers which fasten the compressor. (See Fig. 11)
6. Remove the compressor.
7. Re-install the components by referring to the removal procedure, above.

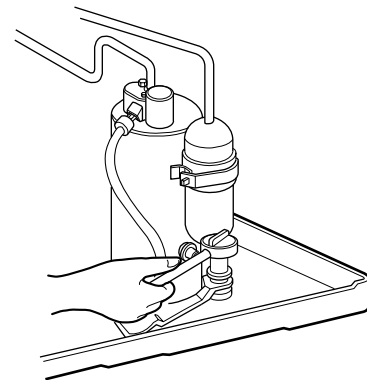

Figure 11

### 2.3.3 CAPACITOR

1. Remove the control box. (Refer to section 2.1.3)
2. Remove knobs and the tips which fasten the display panel.
3. Disconnect the 2 leads from the rocker switch and remove the panel (Energy saver model only).
4. Remove 2 screws and unfold the control box. (See Fig. 12)
5. Remove the Rotary Switch.
6. Remove the screw and the clamp which fastens the capacitor. (See Fig. 12)
7. Disconnect all the leads of capacitor terminals.
8. Re-install the components by referring to the removal procedure, above.

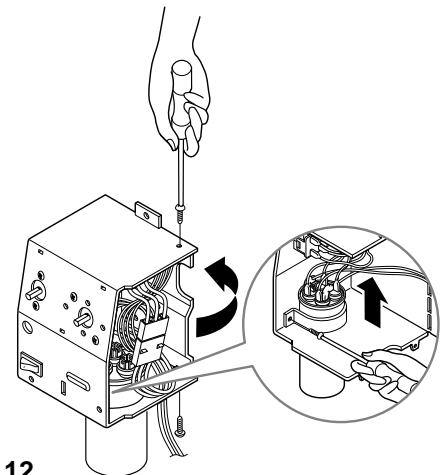

Figure 12

### 2.3.4 POWER CORD

1. Remove the control box. (Refer to section 2.1.3)
2. Unfold the control box. (Refer to section 2.3.3)
3. Disconnect the grounding screw from the control box.
4. Disconnect 2 receptacles.
5. Remove a screw which fastens the clip cord.
6. Pull the power cord. (See Fig. 13)
7. Re-install the component by referring to the removal procedure, above.  
(Use only one ground-marked hole ⊕ for ground connection.)
8. If the supply cord of this appliance is damaged, it must be replaced by the special cord.  
(The special cord means the cord which has the same specification marked on the supply cord fitted to the unit.)

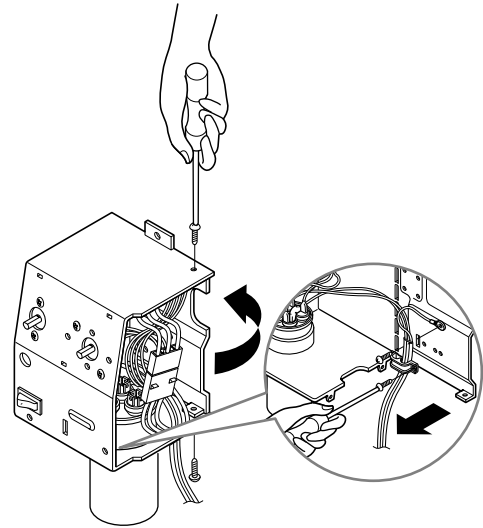

Figure 13

### 2.3.5 THERMOSTAT

1. Remove the control box. (Refer to section 2.1.3)
2. Unfold the control box. (Refer to section 2.3.3)
3. Remove the 2 screws which fasten the thermostat.
4. Disconnect all the leads of thermostat terminals.
5. Remove the thermostat. (See Fig. 14)
6. Re-install the components by referring to the removal procedure, above.

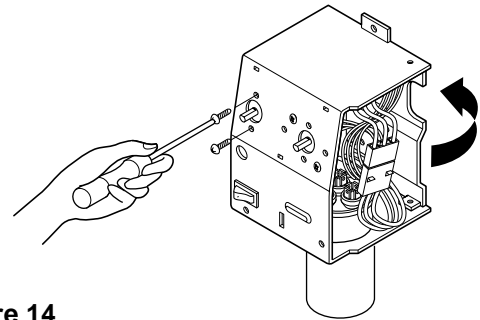

Figure 14

### 2.3.6 ROTARY SWITCH

1. Remove the control box. (Refer to section 2.1.3)
2. Unfold the control box. (Refer to section 2.3.3)
3. Remove 2 screws which fasten the rotary switch.
4. Disconnect all the leads of the rotary switch terminals.
5. Remove the rotary switch. (See Fig. 15)
6. Re-install the components by referring to the above removal procedure, above.

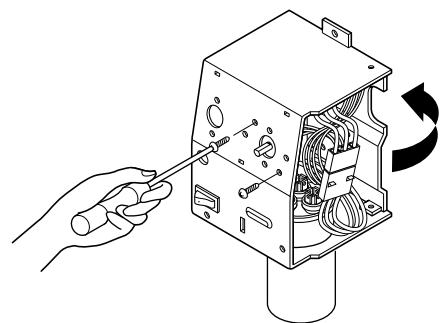

Figure 15

## 2.4 REFRIGERATION CYCLE

### CAUTION

Discharge the refrigerant system using Freon™ Recovery System.  
If there is no valve to attach the recovery system, install one (such as a WATCO A-1) before venting the Freon™. Leave the valve in place after servicing the system.

### 2.4.1 CONDENSER

1. Remove the cabinet. (Refer to section 2.1.2)
2. Remove the brace and the shroud cover. (Refer to section 2.2.1)
3. Remove the 5 screws which fasten the condenser.
4. After discharging the refrigerant completely, unbrazed the interconnecting tube at the condenser connections.
5. Remove the condenser.
6. Re-install the components by referring to notes. (See Fig. 16)

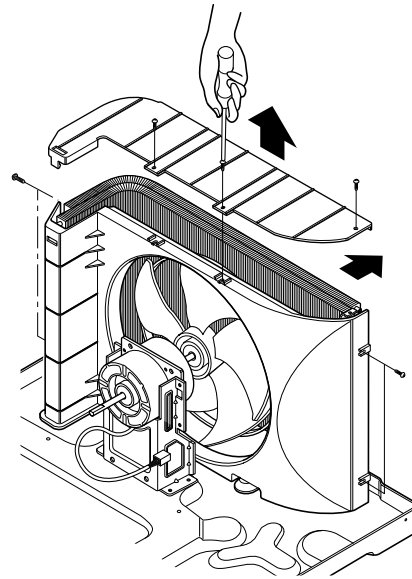

Figure 16

### 2.4.2 EVAPORATOR

1. Remove the cabinet. (Refer to section 2.1.2)
2. Discharge the refrigerant completely.
3. Remove the 2 screws which fasten the evaporator at the left side and the right side.
4. Move the evaporator sideward carefully and then unbrazed the interconnecting tube at the evaporator connectors.
5. Remove the evaporator.
6. Re-install the components by referring to notes. (See Fig. 17)

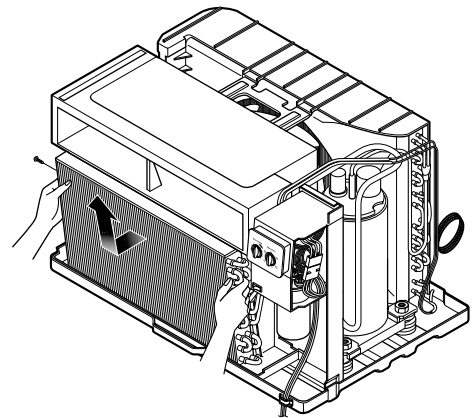

Figure 17

### 2.4.3 CAPILLARY TUBE

1. Remove the cabinet. (Refer to section 2.1.2)
2. After discharging the refrigerant completely, unbrazed the interconnecting tube at the capillary tube.
3. Remove the capillary tube.
4. Re-install the components by referring to notes.

## NOTES

— Replacement of the refrigeration cycle.

1. When replacing the refrigeration cycle, be sure to discharge the refrigerant system using a Freon™ recovery System.  
If there is no valve to attach the recovery system, install one (such as a WATCO A-1) before venting the Freon™. Leave the valve in place after servicing the system.
2. After discharging the unit completely, remove the desired component, and unbrace the pinch-off tubes.
3. Solder service valves into the pinch-off tube ports, leaving the valves open.
4. Solder the pinch-off tubes with Service valves.
5. Evacuate as follows.
  - 1) Connect the vacuum pump, as illustrated Fig. 18A.
  - 2) Start the vacuum pump, slowly open manifold valves A and B with two full turns counterclockwise and leave the valves closed. The vacuum pump is now pulling through valves A and B up to valve C by means of the manifold and entire system.

### CAUTION

If high vacuum equipment is used, just crack valves A and B for a few minutes, then open slowly with the two full turns counterclockwise. This will keep oil from foaming and being drawn into the vacuum pump.

- 3) Operate the vacuum pump for 20 to 30 minutes, until 600 microns of vacuum is obtained. Close valves A and B, and observe vacuum gauge for a few minutes. A rise in pressure would indicate a possible leak or moisture remaining in the system. With valves A and B closed, stop the vacuum pump.
- 4) Remove the hose from the vacuum pump and place it on the charging cylinder. See Fig. 18B. Open valve C.  
Discharge the line at the manifold connection.
- 5) The system is now ready for final charging.

6. Recharge as follows :

- 1) Refrigeration cycle systems are charged from the High-side. If the total charge cannot be put in the High-side, the balance will be put in the suction line through the access valve which you installed as the system was opened.
- 2) Connect the charging cylinder as shown in Fig. 18B. With valve C open, discharge the hose at the manifold connection.
- 3) Open valve A and allow the proper charge to enter the system. Valve B is still closed.
- 4) If more charge is required, the high-side will not take it. Close valve A.
- 5) With the unit running, open valve B and add the balance of the charge.
  - a. Do not add the liquid refrigerant to the Low-side.
  - b. Watch the Low-side gauge; allow pressure to rise to 30 lbs.
  - c. Turn off valve B and allow pressure to drop.
  - d. Repeat steps B and C until the balance of the charge is in the system.
- 6) When satisfied the unit is operating correctly, use the pinch-off tool with the unit still running and clamp on to the pinch-off tube. Using a tube cutter, cut the pinch-off tube about 2 inches from the pinch-off tool. Use sil-fos solder and solder pinch-off tube closed. Turn off the unit, allow it to set for a while, and then test the leakage of the pinch-off connection.

**Equipment needed:** Vacuum pump, Charging cylinder, Manifold gauge, Brazing equipment. Pinch-off tool capable of making a vapor-proof seal, Leak detector, Tubing cutter, Hand Tools to remove components, Service valve.

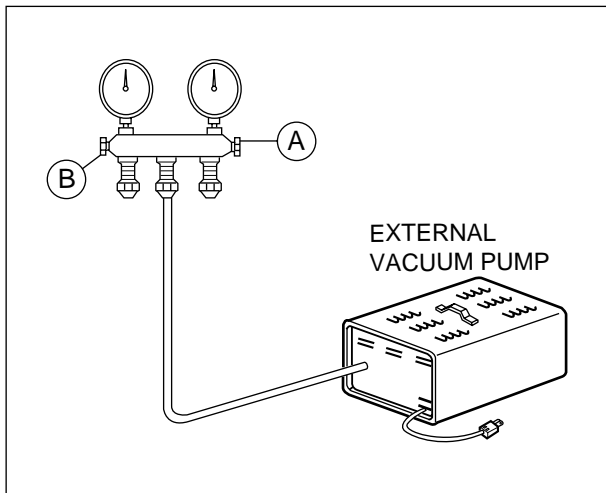
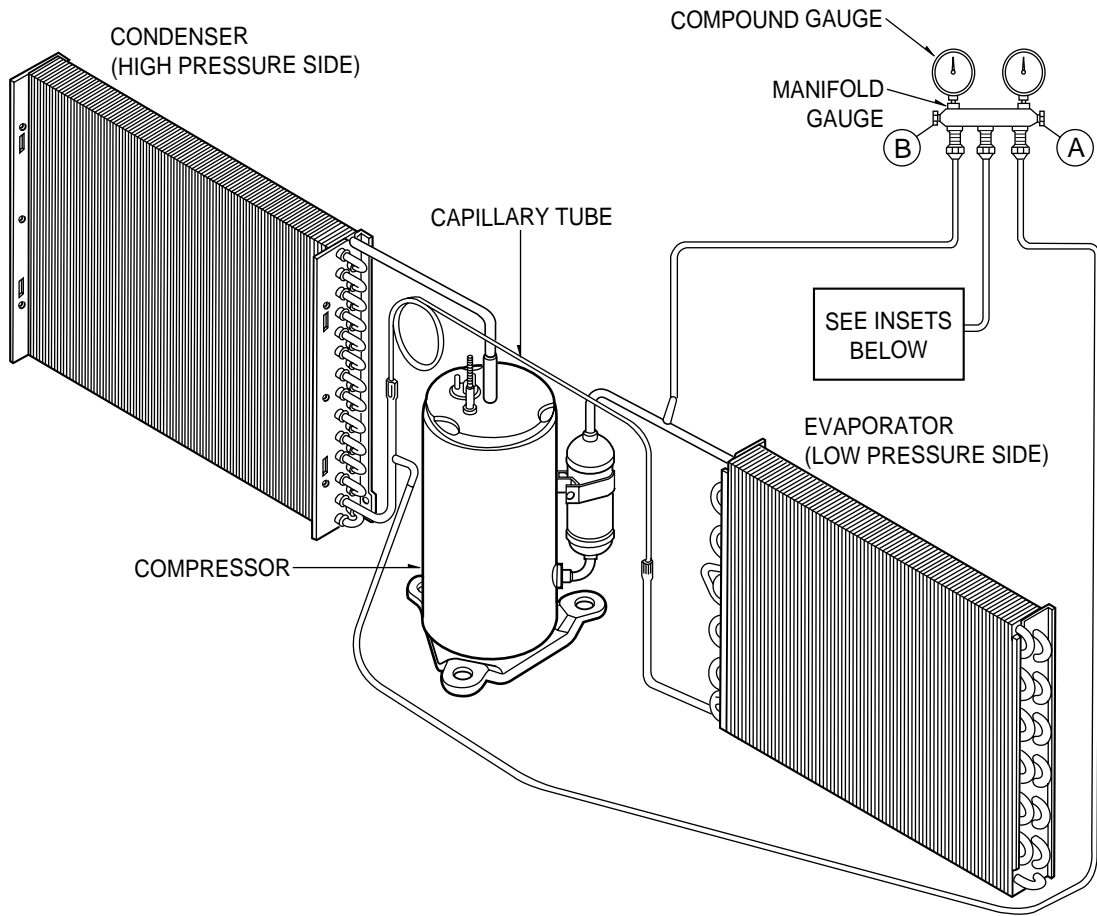

**Figure 18A-Pulling Vacuum**

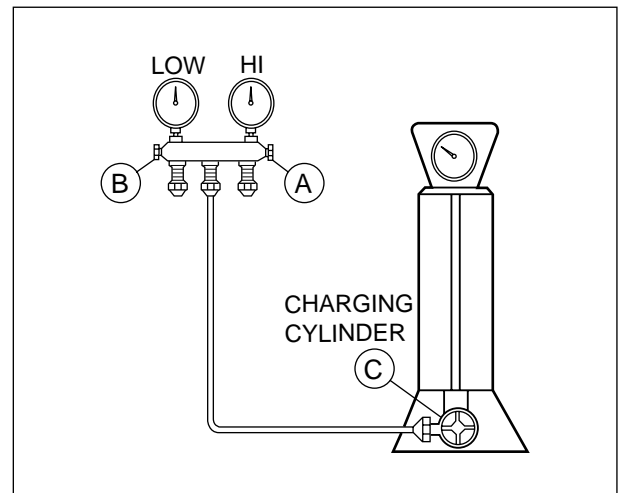

**Figure 18B-Charging**

# 3. INSTALLATION

## 3.1 INSTALLATION REQUIREMENTS

If you use an existing wall sleeve, you should measure its dimensions.

Install the new air conditioner according to these installation instructions to achieve the best performance. All wall sleeves used to mount the new air conditioner must be in good structural condition and have a rear grille to securely attach the new air conditioner. (FIG. 19A)

With the **FRIEDRICH USC sleeve**, you can maintain the best performance of the new air conditioner. (FIG. 19B)

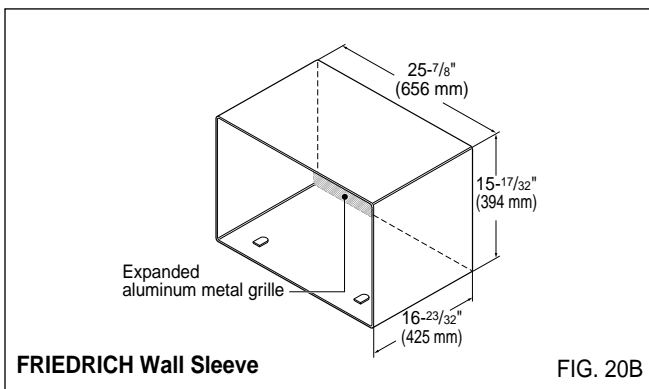
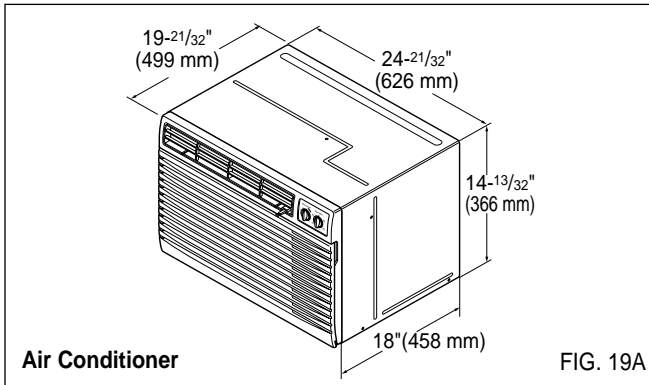

### ELECTRICAL SERVICE

Check your available electrical service. The power supply available must be the same as that shown on the unit nameplate (found on left side of cabinet).

All models are equipped with a 3-prong service plug to provide proper service and safe positive grounding. Do not change plug in any way. Do not use an adapter plug. If your present wall outlet does not match your plug, call a qualified electrician to make the necessary corrections. SAVE CARTON for storage and this OWNER'S MANUAL for future reference. The carton is the best way to store unit during winter or when not in use.

## INSTALLATION HARDWARE

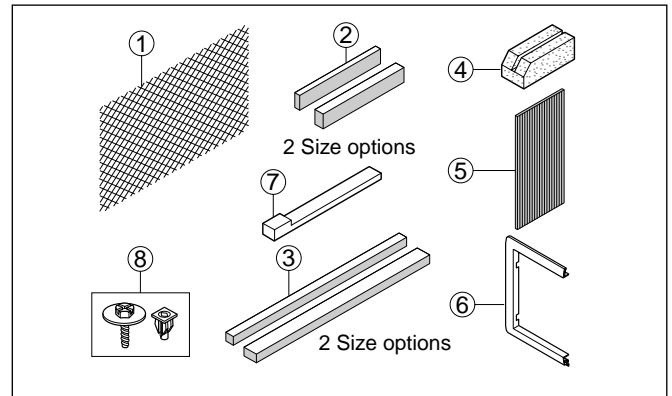

ITEM	NAME OF PARTS	Q'TY
①	PLASTIC GRILLE	1
②	HORIZONTAL INSULATION STRIPS	2
③	AROUND INSULATION STRIPS	2
④	SUPPORT BLOCK	2
⑤	BAFFLE	1
⑥	TRIM FRAME	2
⑦	SHIM	2
⑧	PLASTIC NUTS AND WASHER SCREWS	4

### ⚠ CAUTION

To avoid risk of personal injury, property damage, or product damage due to the weight of this device and sharp edges that may be exposed:

- Air conditioners covered in this manual pose an excessive weight hazard. Two or more people are needed to move and install the unit. To prevent injury or strain, use proper lifting and carrying techniques when moving unit.
- Carefully inspect location where air conditioner will be installed. Be sure it will support the weight of the unit over an extended period of time.
- Handle air conditioner with care. Wear protective gloves whenever lifting or carrying the unit. AVOID the sharp metal fins of front and rear coils.
- Make sure air conditioner does not fall during installation.

### REQUIRED TOOLS:

- Tight Fitting gloves
- Standard screwdriver
- Phillips screwdriver
- Pliers
- Sharp knife
- 3/8-inch open end wrench or adjustable wrench
- 1/4-inch hex socket and ratchet
- Tape measure
- Electric drill
- 1/4-inch drill bit

## 3.2 INSTALLATION

### CAUTION

**We strongly recommend the removal of the old wall sleeve and the installation of a new FRIEDRICH USC Wall Sleeve.**

If you decide to keep the existing wall sleeve, you have to redirect the louvers at the back of the wall sleeve illustration. The use of pliers is recommended. If you DO NOT redirect, you run the risk of poor performance or product failure. This is not covered under the terms of the FRIEDRICH warranty.

- Pick a location which will allow the conditioned air to blow into the area you want. Good installation with special attention to the proper position of the unit will lessen the chance that service will be needed.

### ITEMS IN INSTALLATION HARDWARE

You may not need all parts in the kit. Discard unused parts

ITEM (inches)	Qty.	
Plastic grille	26 <sup>3</sup> / <sub>4</sub> x 16 <sup>1</sup> / <sub>2</sub>	1
Horizontal Insulation Strips	1 <sup>3</sup> / <sub>8</sub> x 5 <sup>5</sup> / <sub>8</sub> x 27 <sup>3</sup> / <sub>16</sub>	1
	1 <sup>3</sup> / <sub>8</sub> x 1 <sup>3</sup> / <sub>8</sub> x 27 <sup>3</sup> / <sub>16</sub>	1
Around Insulation Strips	1 <sup>3</sup> / <sub>8</sub> x 3 <sup>3</sup> / <sub>4</sub> x 61 <sup>1</sup> / <sub>2</sub>	1
	1 <sup>3</sup> / <sub>8</sub> x 1 <sup>3</sup> / <sub>8</sub> x 61 <sup>1</sup> / <sub>2</sub>	1
Support Block	1 <sup>3</sup> / <sub>4</sub> x 1 <sup>3</sup> / <sub>8</sub> x 4 <sup>5</sup> / <sub>16</sub>	2
Baffle	14 x 4 <sup>1</sup> / <sub>2</sub> x 1 <sup>1</sup> / <sub>8</sub>	1
Shim	13 x 1 x 3 <sup>3</sup> / <sub>4</sub>	2
Trim Frame		2
Washer Screw		4
Nuts(Plastic)		4

### HOW TO INSTALL

- 1 Identify the existing wall sleeve before installing the unit from the listed below.

Brand	Wall Sleeve Dimensions (inches)		
	Width	Height	Depth
White-Westinghouse Frigidaire Carrier (52F series)	25-1/2	15-1/4	16, 17-1/2 or 22
General Electric /Hotpoint	26	15-5/8	16-7/8
Whirlpool	25-7/8	16-1/2	17-1/8 or 23
Fedders/Emerson Friedrich WSC	27	16-3/4	16-3/4 or 19-3/4
FRIEDRICH USC	25-7/8	15-17/32	16-23/32
Emerson/Fedders	26-3/4	15-3/4	15
Carrier (51S Series)	25-3/4	16-7/8	18-5/8

**NOTE:** All wall sleeves used to mount the new Air Conditioner must be in sound structural condition and have a rear grille that securely attaches to sleeve, or rear flange that serves as a stop for the Air Conditioner.

- 2 Remove old air conditioner from existing wall sleeve.
- 3 Clean the interior of an existing sleeve. (Do not disturb seals.)
- 4 Wall sleeve must be securely fastened in wall before installing the air conditioner. Use the nails or screws through sleeve into wall, if needed. Repaint sleeve if needed.
- 5 Prepare the wall sleeve for installation of the unit. If you plan to use your existing wall sleeve, and it is not FRIEDRICH, use procedure B or C below.

Procedure	Brand	Depth(inches)
A	FRIEDRICH USC	16-23/32
B	White-Westinghouse Frigidaire Carrier (52F series)	16, 17-1/2 or 22
	General Electric /Hotpoint	16-7/8
	Whirlpool Carrier (51S series)	17-1/8 or 23 18-5/8
C	Fedders/Emerson	16-3/4 or 19-3/4
	Emerson/Fedders	15

- 6 Install new unit into wall sleeve.

**CAUTION:** When installation is completed, replacement unit MUST have a rearward slope as shown.

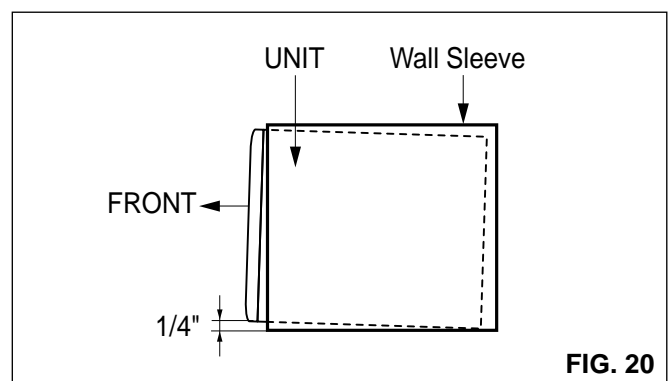

### 3.3 PROCEDURE A

- 1 If you are using the new LGE sleeve supplied with your unit, skip to step 3. Otherwise, install the plastic grille from the kit. Cut the plastic grille to 25-1/2" wide and 15-1/4" high. Place the plastic grille to the inside of the wall sleeve at the rear flange.

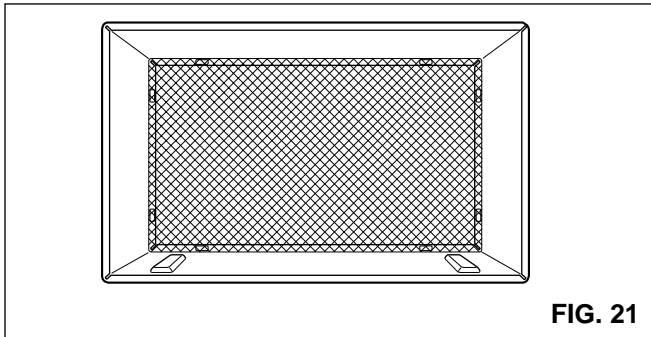

FIG. 21

- 2 Fasten the 4 washer screws to secure the grille to the wall sleeve. If you need plastic nuts to mount plastic grille to the inside of the wall sleeve, there are plastic nuts in the installation kit. The nuts are installed from the inside of the sleeve and are pressed into the square holes of the rear flanges.

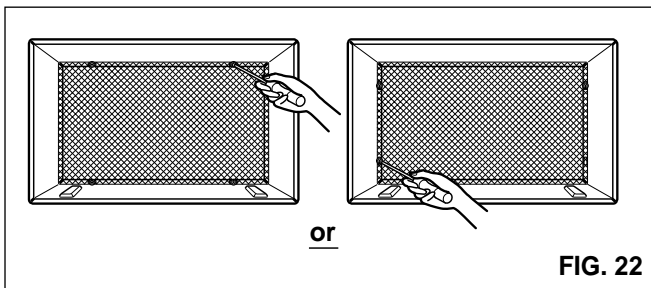

FIG. 22

- 3 Remove the backing from the Horizontal Insulation strip  $1\frac{3}{8} \times \frac{3}{8} \times 27\frac{3}{16}$  and attach that to the inside bottom of the sleeve as shown below. Remove the backing from the Around Insulation strip  $1\frac{3}{8} \times \frac{3}{4} \times 61\frac{1}{2}$  and attach that to the inside front of the sleeve as shown below.

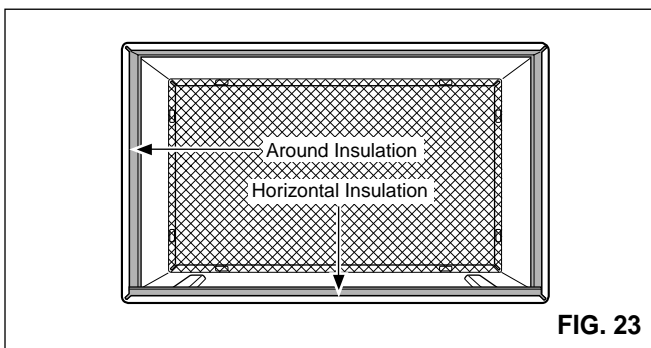

FIG. 23

- 4 Install the new unit into the wall sleeve.
- 5 To assemble trim, snap the tab of each piece into the slot of the other piece as shown below. Slide trim over the front of the air conditioner until trim is flush with sleeve as shown below.

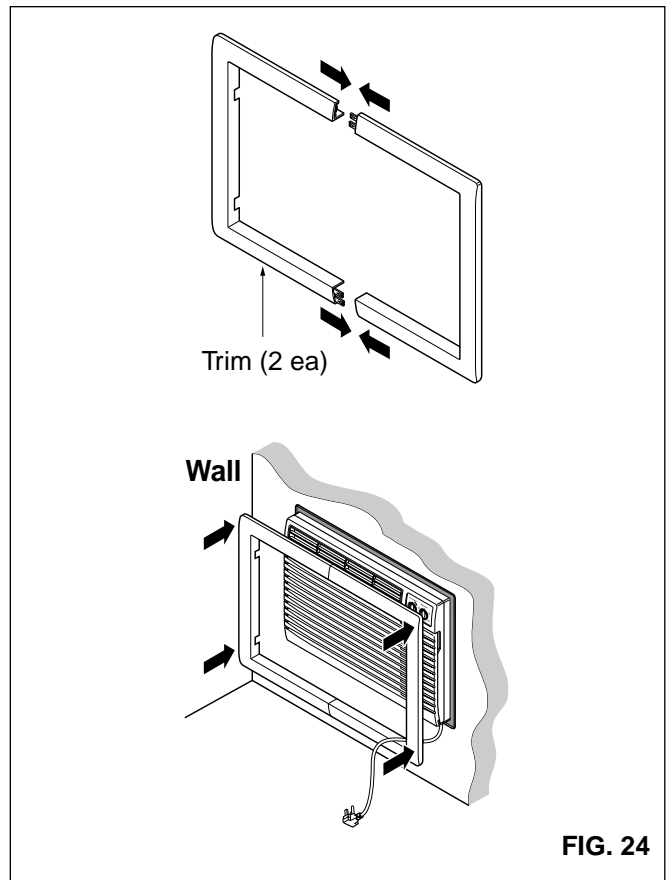

FIG. 24

#### CAUTION

- Air conditioners covered in this manual pose an excessive weight hazard. Two or more people are needed to move and install the unit. To prevent injury or strain, use proper lifting and carrying techniques when moving unit.
- When handling the air conditioner, be careful to avoid cuts from sharp metal fins on front and rear coils.
- Make sure air conditioner does not fall during removal.

### 3.4 PROCEDURE B

- 1 Redirect the louvers at the back of the wall sleeve to 60° angle as shown in the FIG 25. The use of pliers is recommended.

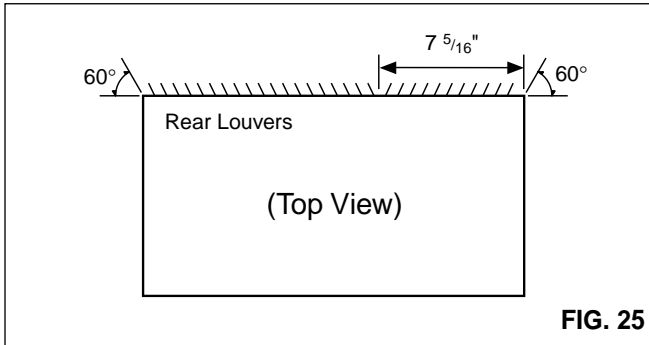

FIG. 25

- 2 If the wall sleeve already has a rear grille, skip to step 4. If the wall sleeve does not have a rear grille or louvered panel, install the plastic grille from the kit. Cut the plastic grille to 25-1/2" wide and 15-1/4" high. Place the plastic grille to the inside of the wall sleeve at the rear flange.

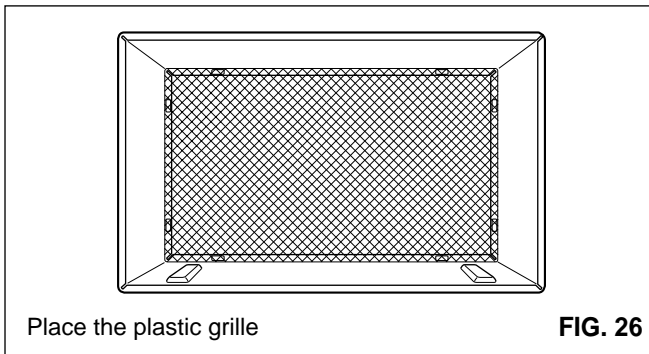

FIG. 26

- 3 Fasten the 4 washer screws to secure the grille to the wall sleeve. If you need plastic nuts to mount plastic grille to the inside of the wall sleeve, there are plastic nuts in the installation kit. The nuts are installed from the inside of the sleeve and are pressed into the square holes of the rear flanges.

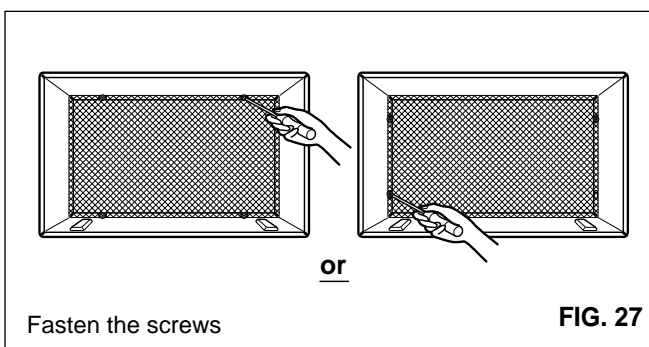

FIG. 27

- 4 Remove the backing from the Horizontal Insulation strip  $1\frac{3}{8} \times \frac{5}{8} \times 27\frac{3}{16}$  and attach that to the inside bottom of the sleeve as shown below. Remove the backing from the Around Insulation strip  $1\frac{3}{8} \times \frac{3}{4} \times 61\frac{1}{2}$  and attach that to the inside front of the sleeve as shown below.

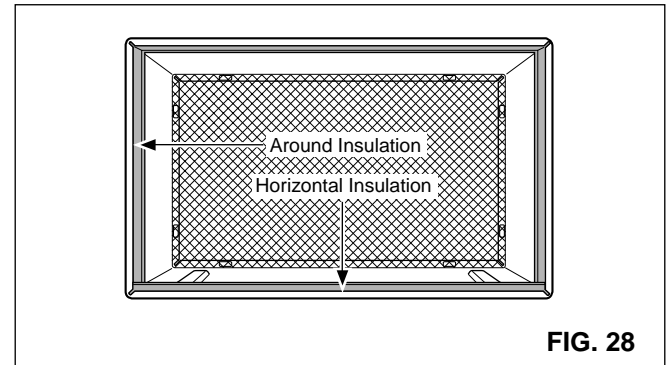

FIG. 28

- 5 If the depth of your existing wall sleeve is less than or equal to 18", skip to step 7. Otherwise, cut the baffles and the support blocks according to length "A" in the table below.

Depth "D" of the existing wall sleeve (inches)	Length "A" (inches)
$18 < D \leq 18\text{-}\frac{5}{8}$	$\frac{3}{4}$
$18\text{-}\frac{5}{8} < D \leq 19\text{-}\frac{3}{4}$	$1\text{-}\frac{3}{4}$
$19\text{-}\frac{3}{4} < D \leq 22$	4

FIG. 29

- 6 Remove the backing from the support blocks and attach them to the inside of the wall sleeve as shown FIG 30. Slide the baffle into slots of the support blocks.

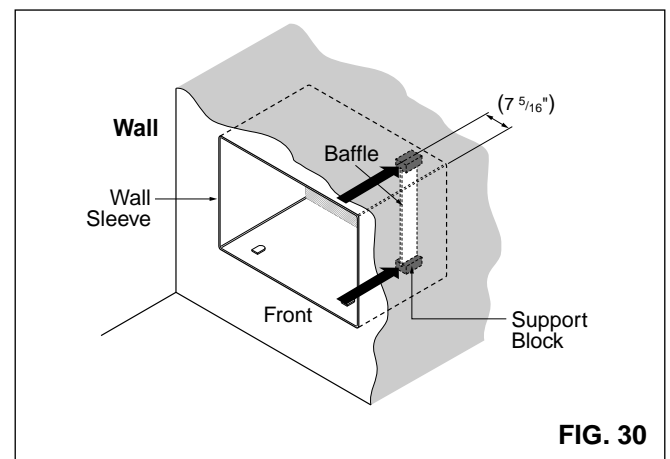
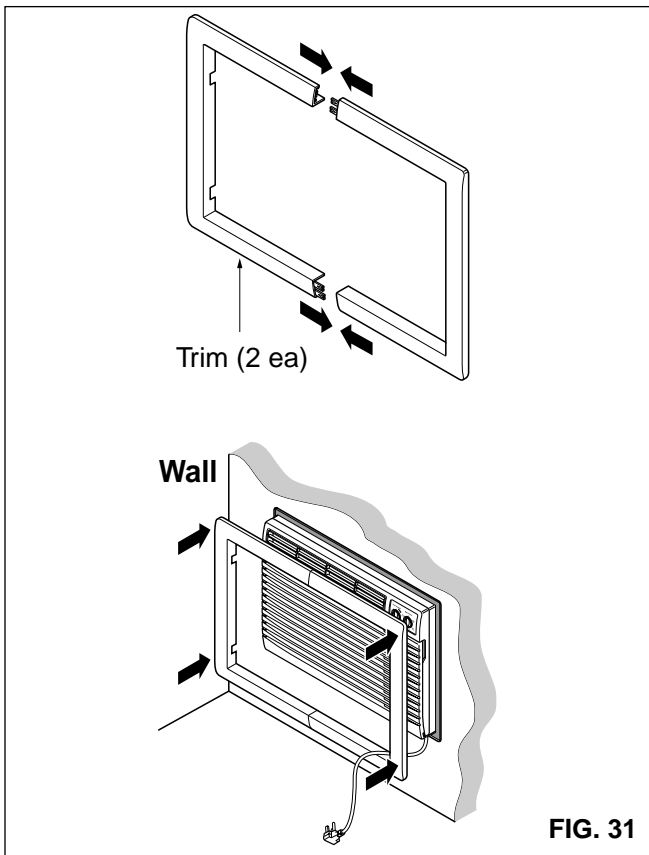

FIG. 30

- 7 Install the new unit into the wall sleeve.

## PROCEDURE B

- 8** To assemble trim, snap the tab of each piece into the slot of the other piece as shown below. Slide trim over the front of the air conditioner until trim is flush with sleeve as shown below.



### CAUTION

- Air conditioners covered in this manual pose an excessive weight hazard. Two or more people are needed to move and install the unit. To prevent injury or strain, use proper lifting and carrying techniques when moving unit.
- When handling the air conditioner, be careful to avoid cuts from sharp metal fins on front and rear coils.
- Make sure air conditioner does not fall during removal.

### 3.5 PROCEDURE C

- 1 Redirect the louvers at the back of the wall sleeve to 60° angle as shown in the FIG 32. The use of pliers is recommended.

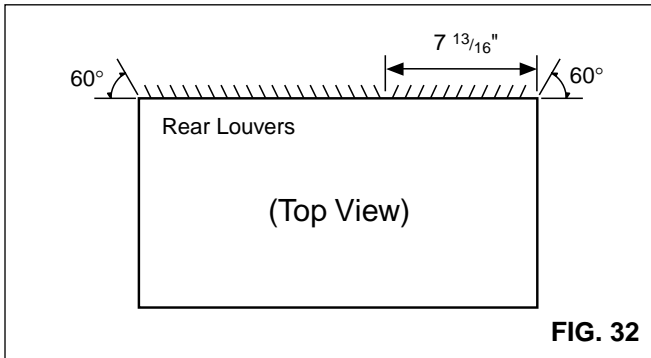
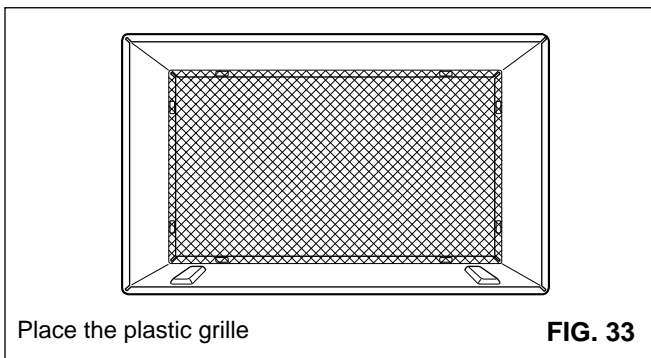

FIG. 32

- 2 If the wall sleeve already has a rear grille, skip to step 4. If the wall sleeve does not have a rear grille or louvered panel, install the plastic grille from the kit. Cut the plastic grille to 26-1/2" wide and 15-1/2" high. Place the plastic grille to the inside of the wall sleeve at the rear flange.



- 3 Fasten the 4 washer screws to secure the grille to the wall sleeve. If you need plastic nuts to mount plastic grille to the inside of the wall sleeve, there are plastic nuts in the installation kit. The nuts are installed from the inside of the sleeve and are pressed into the square holes of the rear flanges.

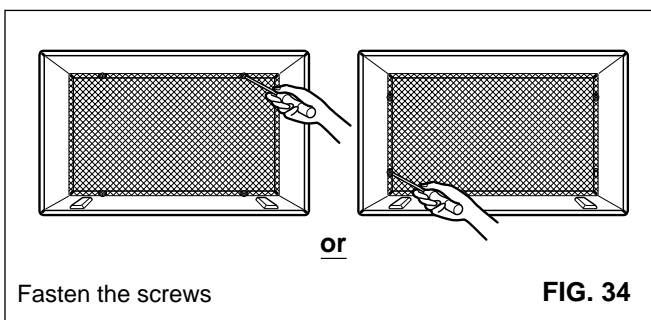

FIG. 34

- 4 Remove the backing from the Horizontal Insulation strip 1 3/8 x 1 3/8 x 27 3/16 and attach that to the inside bottom of the sleeve as shown below. Remove the backing from the Around Insulation strip 1 3/8 x 1 3/8 x 61 1/2 and attach that to the inside front of the sleeve as shown below.

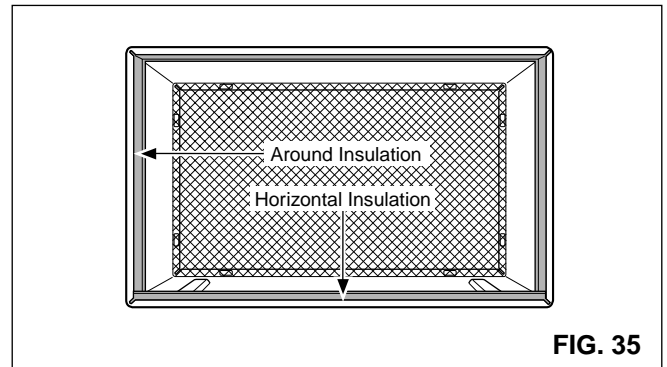

FIG. 35

- 5 If the depth of your existing sleeve is less than or equal to 18", skip to step 7. Otherwise, cut the baffles and the support blocks according to Length "A" in the table below.

Depth "D" of the existing wall sleeve (inches)	Length "A" (inches)
$18 < D \leq 18\text{-}5/8$	$3/4$
$18\text{-}5/8 < D \leq 19\text{-}3/4$	$1\text{-}3/4$
$19\text{-}3/4 < D \leq 22$	4

FIG. 36

- 6 Remove the backing from the support blocks and attach them to the inside of the wall sleeve as shown FIG 37. Slide the baffle into slots of the support blocks

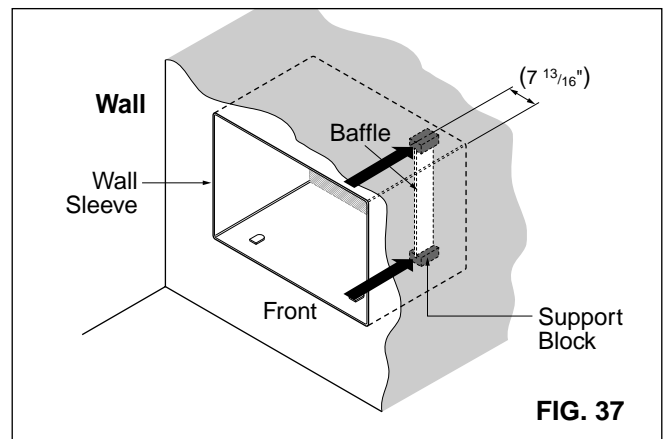
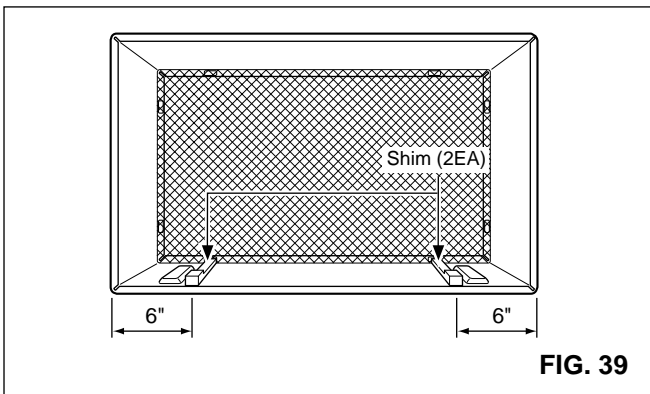
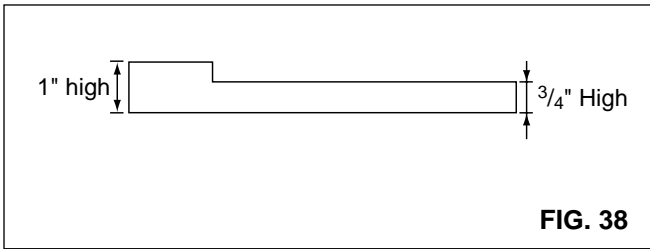

FIG. 37

## PROCEDURE C

- 7** Remove the backing from the 13" shim strips and attach them as shown below in Fig. 39. The higher portion of shim is to be placed in front of the rib on the base of wall sleeve.



- 8** Install the new unit into the wall sleeve

- 9** To assemble trim, snap the tab of each piece into the slot of the other piece as shown below. Slide trim over the front of the air conditioner until trim is flush with sleeve as shown below.

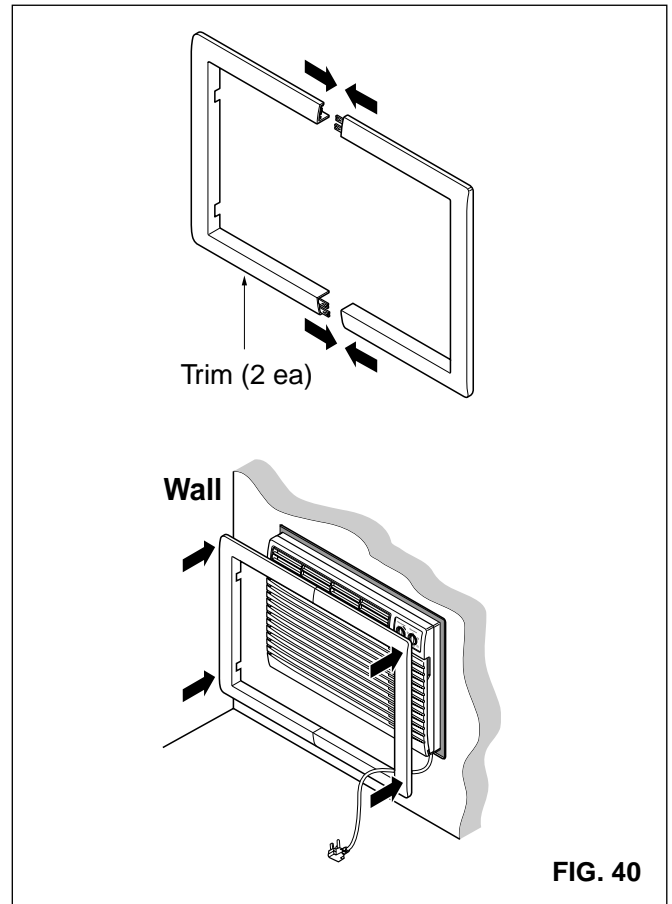

### CAUTION



- Air conditioners covered in this manual pose an excessive weight hazard. Two or more people are needed to move and install the unit. To prevent injury or strain, use proper lifting and carrying techniques when moving unit.
- When handling the air conditioner, be careful to avoid cuts from sharp metal fins on front and rear coils.
- Make sure air conditioner does not fall during removal.

### 3.4 ELECTRICAL REQUIREMENTS

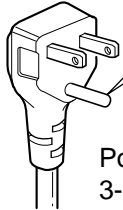
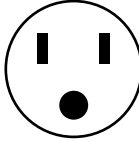
#### 3.4.1 ELECTRICAL DATA (FOR 115V MODEL)

Line Cord Plug	Use Wall Receptacle	Power Supply
 <p data-bbox="368 501 647 562">Power supply cord with 3-prong grounding plug</p>	<p data-bbox="730 409 831 470"><b>Parallel type</b></p>  <p data-bbox="703 501 1098 562">Standard 125V, 3-wire grounding receptacle rated 15A, 125V AC</p>	<p data-bbox="1142 409 1390 501">Use 15 AMP time delay fuse or 15 AMP circuit breaker.</p>
<p data-bbox="252 584 695 613"><b>USE OF EXTENSION CORDS</b></p> <p data-bbox="252 622 1394 683">Because of potential safety hazards, we strongly discourage the use of an extension cord. However, if you wish to use an extension cord, use a CSA certified/UL-listed 3-wire (grounding) extension cord, rated 15A, 125V.</p>		

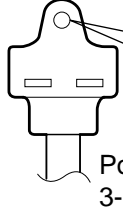
#### 3.4.2 ELECTRICAL DATA (FOR 230/208V MODEL)

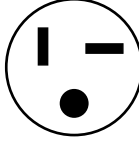
Line Cord Plug	Use Wall Receptacle	Power Supply
 <p data-bbox="368 1023 647 1084">Power supply cord with 3-prong grounding plug</p>	<p data-bbox="730 925 831 985"><b>Tandem type</b></p>  <p data-bbox="695 1023 1090 1084">Standard 250V, 3-wire grounding receptacle rated 15A, 250V AC</p>	<p data-bbox="1126 896 1334 987">Use 15 AMP time delay fuse or circuit breaker.</p>
 <p data-bbox="368 1274 647 1335">Power supply cord with 3-prong grounding plug</p>	<p data-bbox="730 1182 903 1243"><b>Perpendicular type</b></p>  <p data-bbox="695 1274 1090 1335">Standard 250V, 3-wire grounding receptacle rated 20A, 250V AC</p>	<p data-bbox="1126 1144 1390 1301">Use 20 AMP time delay fuse or circuit breaker. Refer to the nameplate for correct fusing.</p>

All wiring should be made in accordance with local electrical codes and regulations.

**NOTE :** Aluminum house wiring may pose special problems. Consult a qualified electrician.

#### 3.4.3 ELECTRICAL SAFETY

##### IMPORTANT GROUNDING INSTRUCTIONS

Air conditioner has a three-prong grounding plug on its power supply cord, which must be plugged into properly grounded three-prong wall receptacle for your protection against possible shock hazard.

**FUSE** – Use a time-delay fuse or circuit breaker. Refer to the nameplate for proper power supply requirements.

##### 208, 230, and 208/230 VOLT UNITS

These units are equipped with a three-prong grounding plug on the power supply cord, which must be plugged into a matching properly grounded three-prong wall receptacle for your protection against possible shock hazard. If such an outlet is not present, one must be installed by a qualified electrician in accordance with the National Electrical Code and local codes and ordinances.

**NOTE:** DO NOT USE AN EXTENSION CORD on 208, 230, and 208/230 Volt units.

# 4. TROUBLESHOOTING GUIDE

## 4.1 OUTSIDE DIMENSIONS

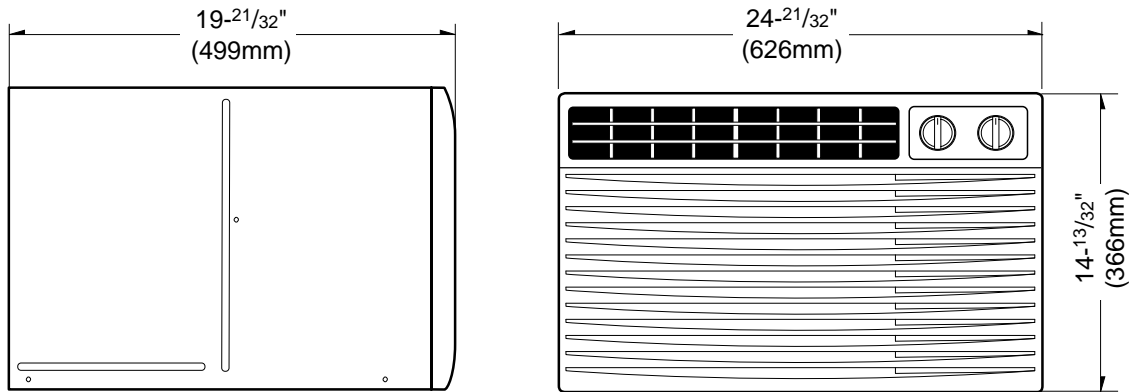

## 4.2 PIPING SYSTEM

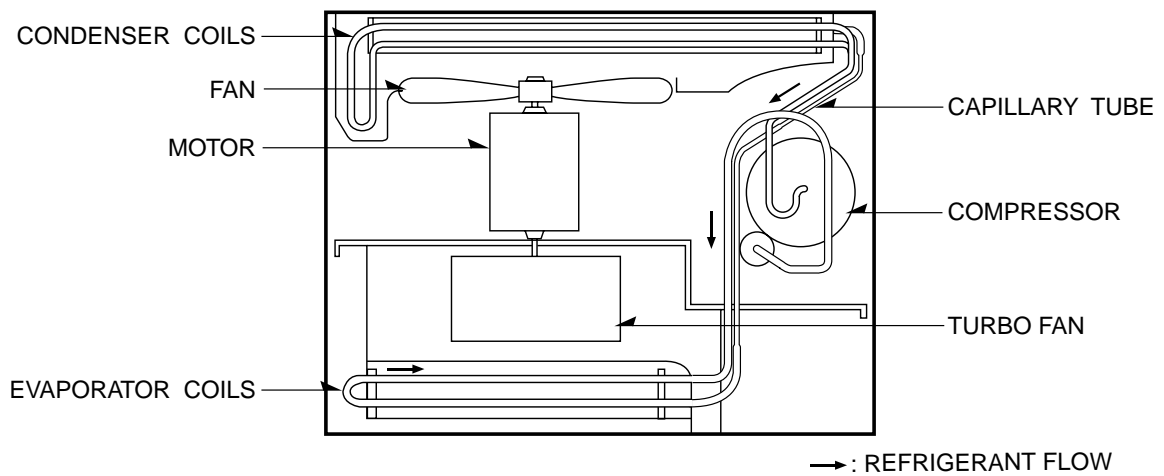

Following is a brief description of the important components and their functions in the refrigeration system. Refer to Fig. 41 to follow the refrigeration cycle and the flow of the refrigerant in the cooling cycle.

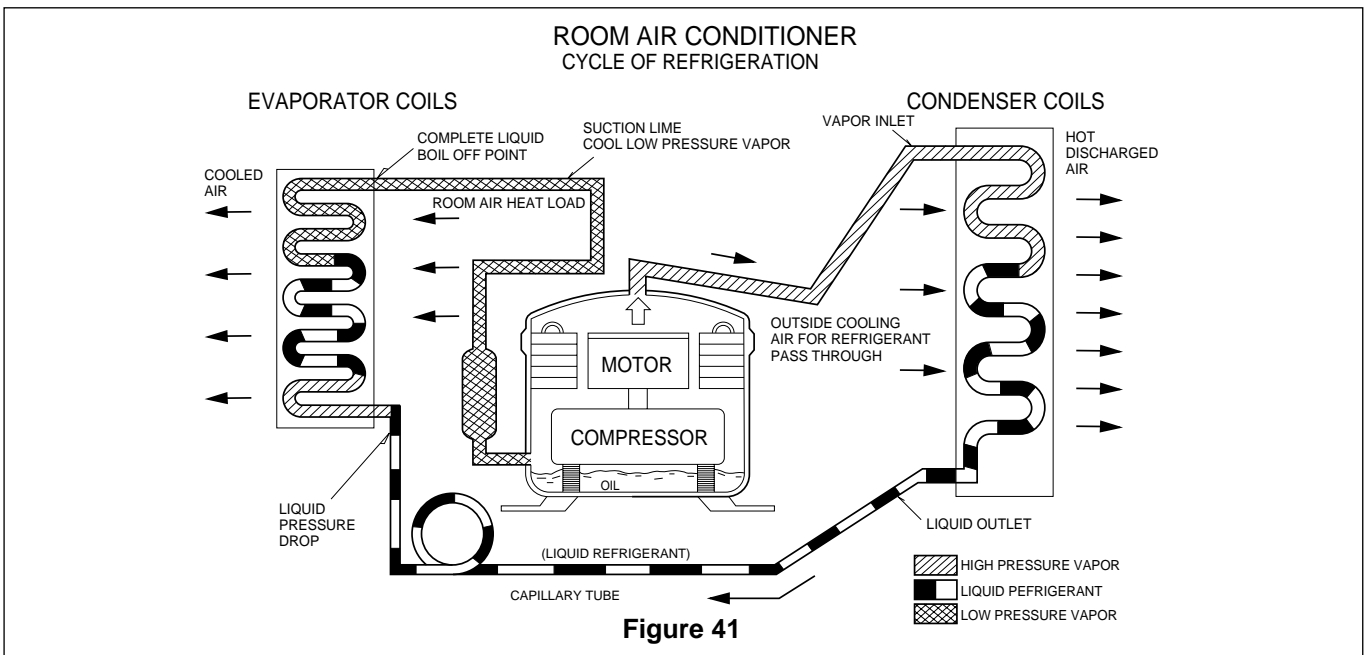

### 4.3 TROUBLESHOOTING GUIDE

In general, possible trouble is classified in two causes.

The one is called Starting Failure which is caused from an electrical defect, and the other is Ineffective Air Conditioning caused by a defect in the refrigeration circuit and improper application.

#### Unit is running but cooling is ineffective

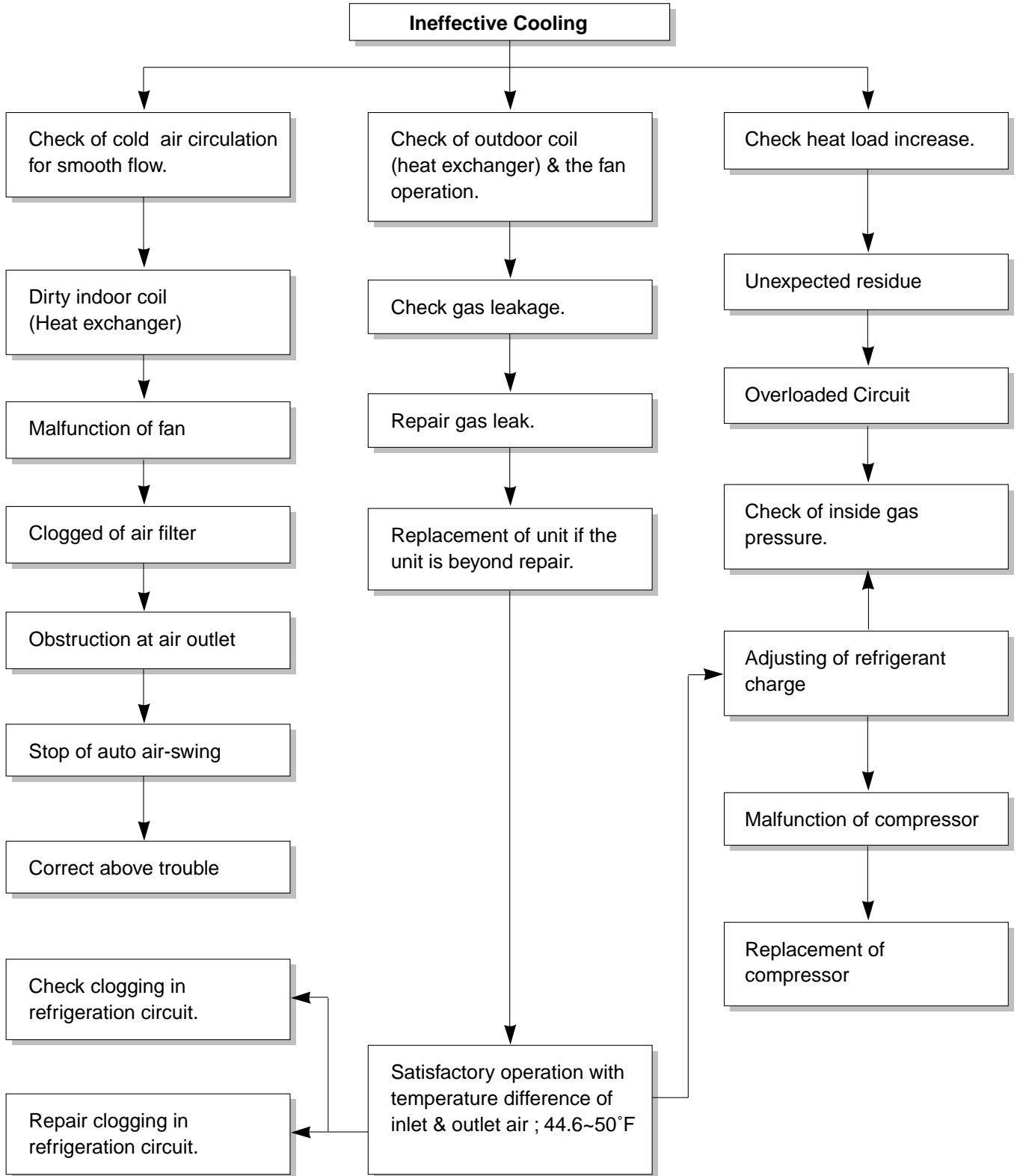

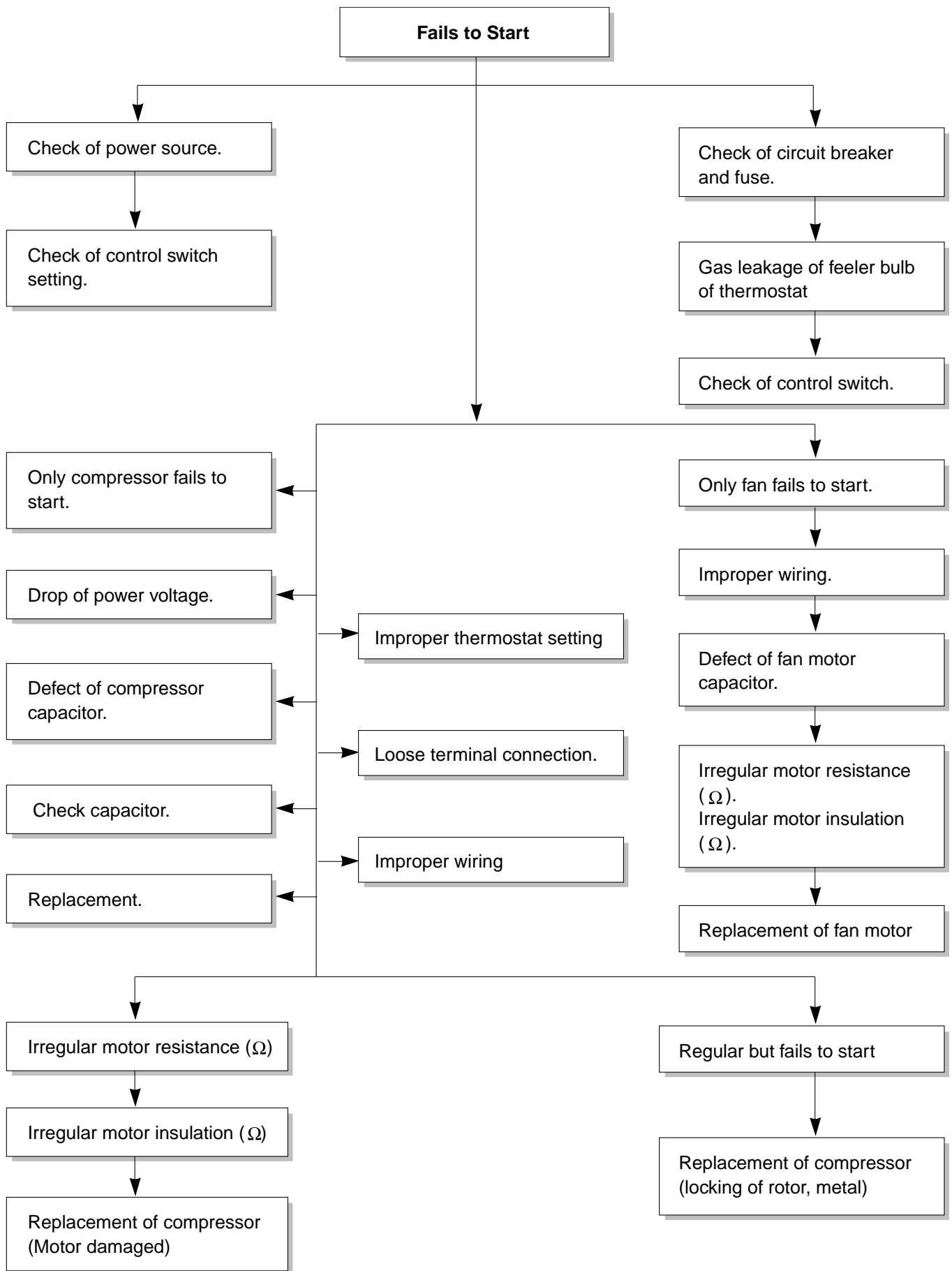

COMPLAINT	CAUSE	REMEDY
Fan motor will not run.	No power	Check voltage at outlet. Correct if none.
	Power supply cord	Check voltage to rotary switch. If none, check power supply cord. Replace cord if circuit is open.
	Rotary switch	Check switch continuity. Refer to wiring diagram for terminal identification. Replace switch if defective.
	Wire disconnected or connection loose	Connect wire. Refer to wiring diagram for terminal identification. Repair or replace loose terminal.
	Capacitor (Discharge capacitor before testing.)	Test capacitor. Replace if not within $\pm 10\%$ of manufacturer's rating. Replace if shorted, open, or damaged.
	Will not rotate	Fan blade hitting shroud or blower wheel hitting scroll. Realign assembly.  Units using slinger ring condenser fans must have $\frac{1}{4}$ to $\frac{5}{16}$ inch clearance to the base. If it is hitting the base, shim up the bottom of the fan motor with mounting screw(s).  Check fan motor bearings; if motor shaft will not rotate, replace the motor.
Fan motor runs intermittently	Revolves on overload.	Check voltage. See limits on this page. If not within limits, call an electrician.  Test capacitor. Check bearings. Does the fan blade rotate freely? If not, replace fan motor.  Pay attention to any change from high speed to low speed. If the speed does not change, replace the motor.
Fan motor noise.	Grommets	Check grommets; if worn or missing, replace them.
	Fan	If cracked, out of balance, or partially missing, replace it.
	Turbo fan	If cracked, out of balance, or partially missing, replace it.
	Loose set screw	Tighten it.
	Worn bearings	If knocking sounds continue when running or loose, replace the motor. If the motor hums or noise appears to be internal while running, replace motor.

<b>COMPLAINT</b>	<b>CAUSE</b>	<b>REMEDY</b>
Compressor will not run, but fan motor runs.	Voltage	Check voltage. See the limits on the preceding page. If not within limits, call an electrician.
	Wiring	Check the wire connections, if loose, repair or replace the terminal. If wires are off, refer to wiring diagram for identification, and replace. Check wire locations. If not per wiring diagram, correct.
	Rotary	Check for continuity, refer to the wiring diagram for terminal identification. Replace the switch if circuit is open.
	Thermostat	Check the position of knob. If not at the coldest setting, advance the knob to this setting and restart unit. Check continuity of the thermostat. Replace thermostat if circuit is open.
	Capacitor (Discharge capacitor before servicing.)	Check the capacitor. Replace if not within $\pm 10\%$ of manufacturer's rating. Replace if shorted, open, or damaged.
	Compressor	Check the compressor for open circuit or ground. If open or grounded, replace the compressor.
	Overload	Check the compressor overload, if externally mounted. Replace if open. (If the compressor temperature is high, remove the overload, cool it, and retest.)

## ROOM AIR CONDITIONER VOLTAGE LIMITS

<b>NAME PLATE RATING</b>	<b>MINIMUM</b>	<b>MAXIMUM</b>
115V	103.5V	126.5V
208/230V	187V	253V

<b>COMPLAINT</b>	<b>CAUSE</b>	<b>REMEDY</b>
Compressor cycles on overload.	Voltage	Check the voltage. See the limits on the preceding page. If not within limits, call an electrician.
	Overload	Check overload, if externally mounted. Replace if open. (If the compressor temperature is high, remove the overload, cool, and retest.)
	Fan motor	If not running, determine the cause. Replace if required.
	Condenser air flow restriction	Remove the cabinet. inspect the interior surface of the condenser; if restricted, clean carefully with a vacuum cleaner (do not damage fins) or brush. Clean the interior base before reassembling.
	Condenser fins (damaged)	If condenser fins are closed over a large area on the coil surface, head pressures will increase, causing the compressor to cycle. Straighten the fins or replace the coil.
	Capacitor	Test capacitor.
	Wiring	Check the terminals. If loose, repair or replace.
	Refrigerating system	Check the system for a restriction.
Insufficient cooling or heating	Air filter	If restricted, clean or replace.
	Exhaust damper door	Close if open.
	Unit undersized	Determine if the unit is properly sized for the area to be cooled.
Excessive noise.	Blower or fan	Check the set screw or clamp. If loose or missing, correct. If the blower or fan is hitting air guide, rearrange the air handling parts.
	Copper tubing	Remove the cabinet and carefully rearrange tubing not to contact cabinet, compressor, shroud, and barrier.

# 5. SCHEMATIC DIAGRAM

## 5.1 CIRCUIT DIAGRAM

• MODEL : US08A10A/US10A10A/US12A10A/US10A30A/US12A30A

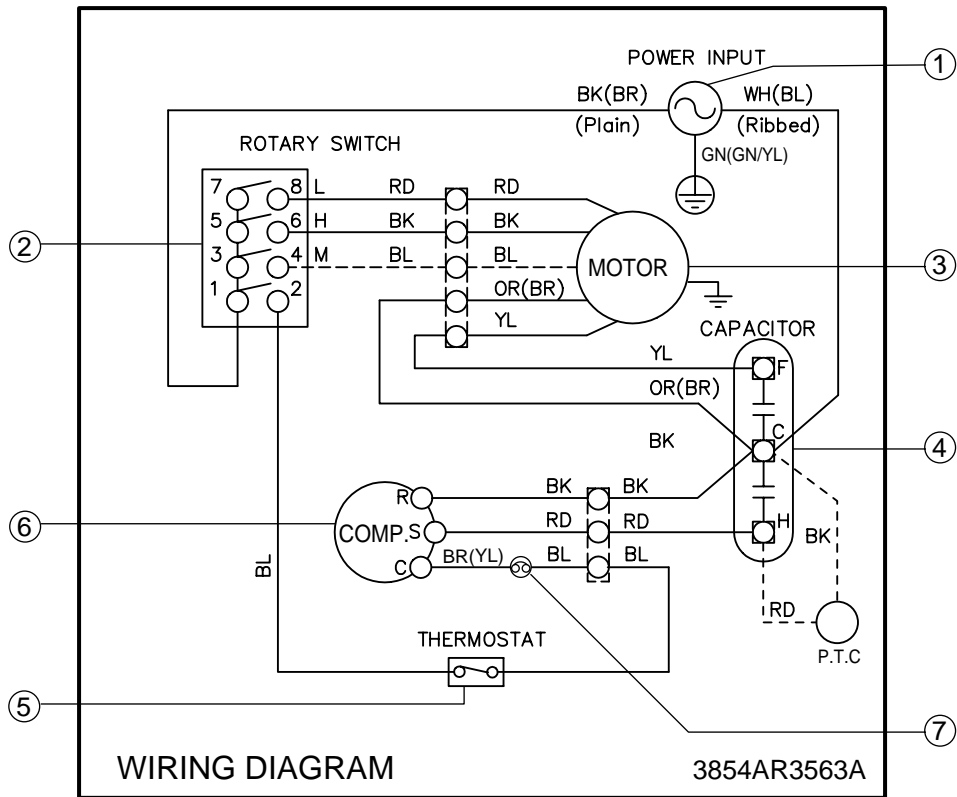

LOCATION NO.	DESCRIPTION	PART NO.					Q'TY PER SET	RE-MARKS
		US08A10A	US10A10A	US12A10A	US10A30A	US12A30A		
1	POWER CORD	2H00677R		2H00677S	2H00677G		1	
2	ROTARY SWITCH	2H00598E					1	
3	FAN MOTOR	4681A20044G	4681A20044F	4681A20041D	4681A20044E	4681A20041C	1	
4	CAPACITOR	6120AR2194P	6120AR2194K	2A00986Y	6120AR2194D		1	
5	THERMOSTAT	2H01109M					1	
6	COMPRESSOR	2520UAFC2AC	2520UKC2AC	2520UKGC2DA	2520UKCK2BA	2520UKHK2CA	1	
7	OVERLOAD PROTECTOR	6750U-L005A	6750U-L031A	6750U-L004A	6750U-L028A	6750U-058A	1	

• MODEL : UE08A13A/UE10A33A/UE12A33A

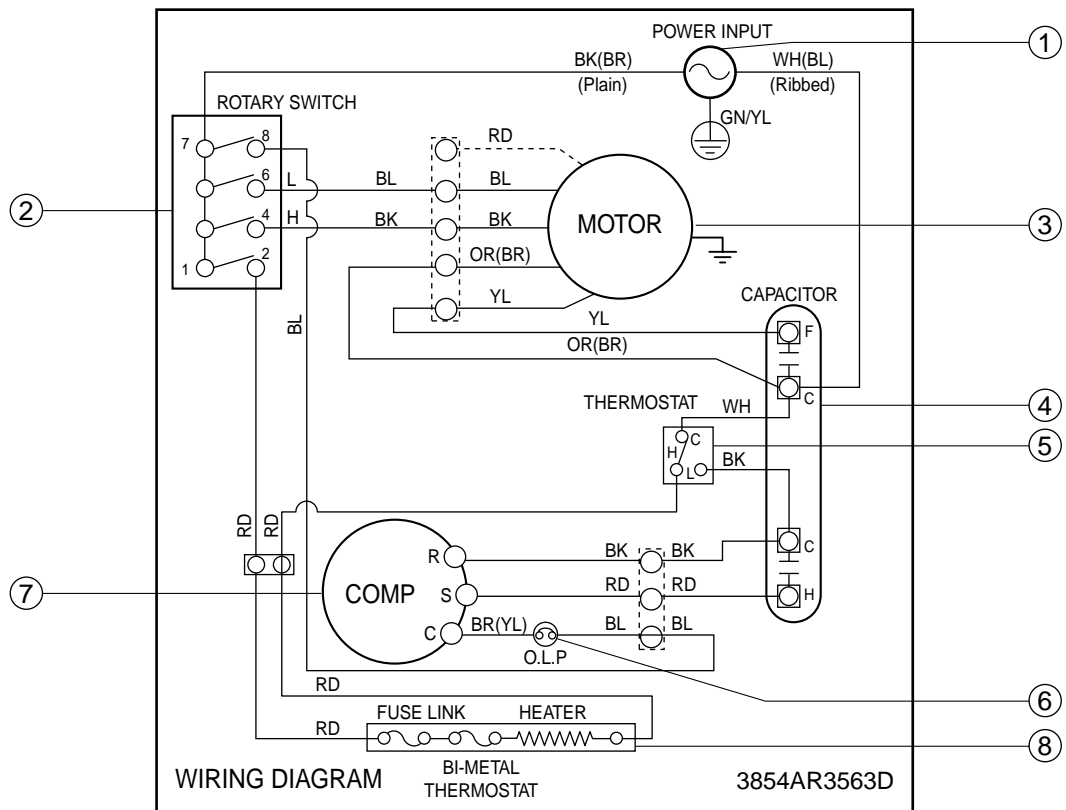

NO.	DESCRIPTION	PART NO.			Q'TY PER SET	RE-MARKS
		UE08A13A	UE10A33A	UE12A33A		
1	POWER CORD	2H00677S	2H00677U		1	
2	ROTARY SWITCH	2H00598F			1	
3	FAN MOTOR	4681A20044G	4681A20044E	4681A20041C	1	
4	CAPACITOR	6120AR2359H	6120AR2359E		1	
5	THERMOSTAT	2H01127D			1	
6	COMPRESSOR	2520U AFC2AC	2520UKCK2BA	2520UKHK2CA	1	
7	OVERLOAD PROTECTOR	6750U-L005A	6750U-L028A	6750U-L058A	1	
8	ELECTRIC HEATER	5300A20003B	5300A20003A		1	

# 6. EXPLODED VIEW

• MODEL: US08A10A/US10A10A/US12A10A/US10A30A/US12A30A/UE08A13A/UE10A33A/UE12A33A

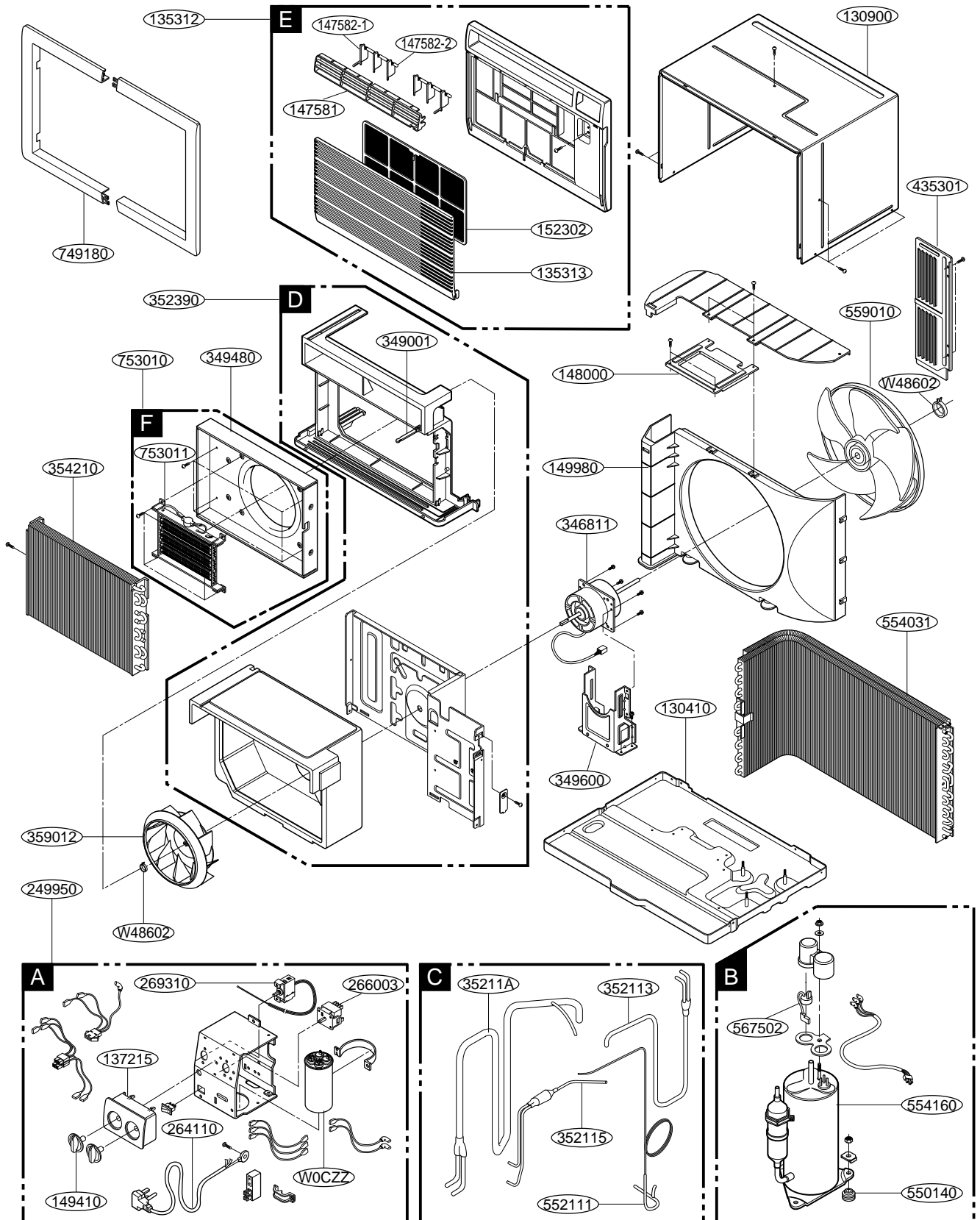

# 7. REPLACEMENT PARTS LIST

• MODEL: US08A10A/US10A10A/US12A10A

R: Service Parts  
N: Non Service parts

	LOCATION NO.	DESCRIPTION	PART NO.			REMARK
			US08A10A	US10A10A	US12A10A	
<b>A</b>	249950	CONTROL BOX ASSY, SINGLE	4995A20131U	4995A20131T	4995A20131S	R
	264110	POWER CORD ASSY	2H00677R		2H00677S	R
	266003	SWITCH, ROTARY	2H00598E			R
	269310	THERMOSTAT ASSY	2H01109M			R
	W0CZZ	CAPACITOR, DRAWING	6120AR2194P	6120AR2194K	2A00986Y	R
	149410	KNOB ASSY	4941A30005B			R
	137215	PANEL ASSY, CONTROL	3721A20049E			R
<b>B</b>	554160	COMPRESSOR	2520UAF2C2AC	2520UKCC2CA	2520UKGC2DA	R
	550140	ISOLATOR, COMP	4H00982E			R
	567502	O.L.P	6750U-L005A	6750U-L031A	6750U-L004A	R
<b>C</b>	352113	TUBE ASSY, DISCHARGE SINGLE	5211A30588C	5211A30588E	5211A30588A	R
	352115	TUBE ASSY, EVAPORATOR IN	5211A20289C	5211A20289D	5211A20904A	R
	352115-1	TUBE ASST, EVAPORATOR IN	-	-	5211A20904B	R
	35211A	TUBE ASSY, SUCTION SINGLE	5211A20498A	5211A20494C	5211A30587A	R
	552111	TUBE ASSY, CAPILLARY	5211A20214N	5211A20214L	5211A20214Q	R
<b>D</b>	352390	AIR GUIDE ASSY	5239A10002E			R
	349001	DAMPER, VENTILATION	4900A20001A			R
<b>E</b>	135312	GRILLE ASSY, FRONT	3531A20121A			R
	135313	GRILLE, INLET	3530A20053A			R
	147581	LOUVER, HORIZONTAL	4758A20008B			R
	147582-1	LOUVER, VERTICAL	4758A20009A			R
	147582-2	LOUVER, VERTICAL	4758A20009B			R
	152302	FILTER(MESH), A/C	5230A20007A			R
	349480	ORIFICE	4948A10006A			R
	149980	SHROUD	4998A10007B			R
	346811	MOTOR ASSY, SINGLE	4681A20044G	4681A20044F	4681A20041D	R
	349600	MOUNT, MOTOR	4960A20005A		4960A20008A	R
	148000	BRACE	4800A30002A			R
	435301	GRILLE, REAR	3530A30002A			R
	354210	EVAPORATOR ASSY, FIRST	5421A20071E		5421A20060A	R
	359012	FAN, TURBO	5900A20009A			R
	554031	CONDENSER ASSY, BENT	5403A20040P		5403A20040K	R
	559010	FAN ASSY, AXIAL	5900AR1173A			R
	W48602	CLAMP, SPRING	3H02932B			R
	130410	BASE ASSY, SINGLE	3041A10014X	3041A10014V	3041A10014T	R
	130900	CABINET	3090A20003B			R
	749180	TRIM	4918A20001A			R

• **MODEL: US10A30A/US12A30A**

R: Service Parts  
N: Non Service parts

	LOCATION NO.	DESCRIPTION	PART NO.		REMARK
			US10A30A	US12A30A	
<b>A</b>	249950	CONTROL BOX ASSY, SINGLE	4995A20131R		R
	264110	POWER CORD ASSY	2H00677G		R
	266003	SWITCH, ROTARY	2H00598E		R
	269310	THERMOSTAT ASSY	2H01109M		R
	W0CZZ	CAPACITOR, DRAWING	6120AR2194D		R
	149410	KNOB ASSY	4941A30005B		R
	137215	PANEL ASSY, CONTROL	3721A20049E		R
<b>B</b>	554160	COMPRESSOR	2520UKCK2BA	2520UKHK2CA	R
	550140	ISOLATOR, COMP	4H00982E		R
	567502	O.L.P	6750U-L028A	6750U-L058A	R
<b>C</b>	352113	TUBE ASSY, DISCHARGE SINGLE	5211A30588B	5211A30588A	R
	352115	TUBE ASSY, EVAPORATOR IN	5211A20289C	5211A20904A	R
	352115-1	TUBE ASST, EVAPORATOR IN	-	5211A20904B	R
	35211A	TUBE ASSY, SUCTION SINGLE	5211A20498B	5211A30587A	R
	552111	TUBE ASSY, CAPILLARY	5211A20214L	5211A20214K	R
<b>D</b>	352390	AIR GUIDE ASSY	5239A10002E		R
	349001	DAMPER VENTILATION	4900A20001A		R
<b>E</b>	135312	GRILLE ASSY, FRONT	3531A20121A		R
	135313	GRILLE, INLET	3530A20053A		R
	147581	LOUVER, HORIZONTAL	4758A20008B		R
	147582-1	LOUVER, VERTICAL	4758A20009A		R
	147582-2	LOUVER, VERTICAL	4758A20009B		R
	152302	FILTER(MESH), A/C	5230A20007A		R
	349480	ORIFICE	4948A10006A		R
	149980	SHROUD	4998A10007B		R
	346811	MOTOR ASSY, SINGLE	4681A20044E	4681A20041C	R
	349600	MOUNT, MOTOR	4960A20005A	4960A20008A	R
	148000	BRACE	4800A30002A		R
	435301	GRILLE, REAR	3530A30002A		R
	354210	EVAPORATOR ASSY, FIRST	5421A20071E	5421A20060A	R
	359012	FAN, TURBO	5900A20009A		R
	554031	CONDENSER ASSY, BENT	5403A20040P	5403A20040H	R
	559010	FAN ASSY, AXIAL	5900AR1173A		R
	W48602	CLAMP, SPRING	3H02932B		R
	130410	BASE ASSY, SINGLE	3041A10014V	3041A10014T	R
	130900	CABINET	3090A20003B		R
	749180	TRIM	4918A20001A		R

• MODEL: UE08A13A/UE10A33A/UE12A33A

R: Service Parts  
N: Non Service parts

	LOCATION NO.	DESCRIPTION	PART NO.			REMARK
			UE08A13A	UE10A33A	UE12A33A	
A	249950	CONTROL BOX ASSY, SINGLE	4995A20131W	4995A20131V		R
	264110	POWER CORD ASSY	2H00677S	2H00677U		R
	266003	SWITCH, ROTARY	2H00598F			R
	269310	THERMOSTAT ASSY	2H01127D			R
	W0CZZ	CAPACITOR, DRAWING	6120AR2359H	6120AR2359E		R
	149410	KNOB ASSY	4941A30005B			R
	137215	PANEL ASSY, CONTROL	3721A20049F			R
B	554160	COMPRESSOR	2520U AFC2AC	2520UKCK2BA	2520UKHK2CA	R
	550140	ISOLATOR, COMP	4H00982E			R
	567502	O.L.P	6750U-L005A	6750U-L028A	6750U-L058A	R
C	352113	TUBE ASSY, DISCHARGE SINGLE	5211A30588C	5211A30588B	5211A30588A	R
	352115	TUBE ASSY, EVAPORATOR IN	5211A20289C	5211A20289C	5211A20904A	R
	352115-1	TUBE ASST, EVAPORATOR IN	-	-	5211A20904B	R
	35211A	TUBE ASSY, SUCTION SINGLE	5211A20498A	5211A20498B	5211A30587A	R
	552111	TUBE ASSY, CAPILLARY	5211A20214N	5211A20214L	5211A20214K	R
D	352390	AIR GUIDE ASSY	5239A10002F			R
	349001	DAMPER, VENTILATION	4900A20001A			R
E	135312	GRILLE ASSY, FRONT	3531A20121C	3531A20121B		R
	135313	GRILLE, INLET	3530A20053A			R
	147581	LOUVER, HORIZONTAL	4758A20008B			R
	147582-1	LOUVER, VERTICAL	4758A20009A			R
	147582-2	LOUVER, VERTICAL	4758A20009B			R
	152302	FILTER(MESH), A/C	5230A20007A			R
F	753010	HEATER ASSY	5301A20011B	5301A20011A		R
	753011	HEATER ASSY, ELECTRIC	5300A20003B	5300A20003A		R
	349480	ORIFICE	4948A10006A			R
	149980	SHROUD	4998A10007B			R
	346811	MOTOR ASSY, SINGLE	4681A20044G	4681A20044E	4681A20041C	R
	349600	MOUNT, MOTOR	4960A20005A		4960A20008A	R
	148000	BRACE	4800A30002A			R
	435301	GRILLE, REAR	3530A30007A			R
	354210	EVAPORATOR ASSY, FIRST	5421A20071E		5421A20060A	R
	359012	FAN, TURBO	5900A20009B			R
	554031	CONDENSER ASSY, BENT	5403A20040P		5403A20040H	R
	559010	FAN ASSY, AXIAL	5900AR1173A			R
	W48602	CLAMP, SPRING	3H02932B			R
	130410	BASE ASSY, SINGLE	3041A10014X	3041A10014V	3041A10014T	R
	130900	CABINET	3090A20003B			R
	749180	TRIM	4918A20001A			R



FRIEDRICH AIR CONDITIONING CO.

Visit our web site at [www.friedrich.com](http://www.friedrich.com)

Post Office Box 1540 • 4200 N. Pan Am Expressway • San Antonio, Texas 78295-1540  
• (210) 357-4400 • FAX (210) 357-4480

P/NO.:3828A20294L

Printed in the U.S.A US08/US10/US12/UE08/UE10/UE12 (2/03)