

This Owner's Manual is provided and hosted by Appliance Factory Parts.

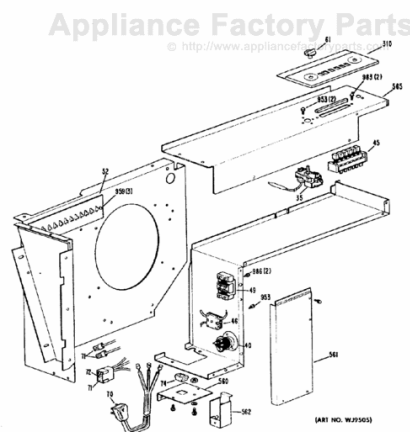

GE A2B348DEALRA Owner's Manual

[Shop genuine replacement parts for GE
A2B348DEALRA](#)

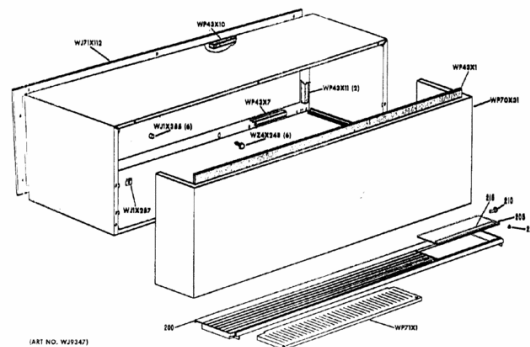

[Find Your GE Air Conditioner Parts - Select From 2757 Models](#)

----- Manual continues below -----

How to get the best from **Your** **Air Conditioner**



Use and Care of Zoneline®
Air Conditioner Models
with two heat and two cool
settings

Energy-saving tips p2

Operating the controls p3

How to clean the air filter p5

Save time and money.
Before you request service,
use the Problem Solver. p6



Your Direct Line to General Electric
The GE Answer Center® 800.626.2000

GENERAL  ELECTRIC 49-7140-1

Contents

	Page
Energy-Saving Tips	2
Important Safety Instructions	2
Operating Your Air Conditioner Controls	3
User Maintenance Instructions	5, 6
Problem Solver	6
Consumer Services	7
Warranty	Back Cover

Energy-Saving Tips

- Keep the air filter clean. (See instructions on page 5.)
- For most efficient operation, keep vent in closed position except when you want to exhaust air, smoke or odors from the room.
- Don't let the room get too hot or too cold. Whenever possible, turn the unit on before the room heats up or cools off. If you don't, your air conditioner will take longer to produce the desired comfort condition.
- Keep windows and doors closed. Conditioned air escapes when they're open.
- Keep furnace floor registers and cold air returns closed when cooling is desired. Cold air can easily escape through them.
- Don't allow curtains, drapes, blinds or other items to block the air discharge grille and restrict air flow when the air conditioner is operating.
- It's best to operate your air conditioner at high speed during extremely hot or cold weather.
- Keep outdoor condenser coil clean. (See page 5.)
- Turn air conditioner off before vacations or extended absences from home.

Help us help you...

Read this book carefully.

It is intended to help you operate and maintain your new air conditioner properly.

Keep it handy for answers to your questions.

If you don't understand something or need more help...

Call, toll-free:

The GE Answer Center™
800.626.2000
consumer information service

or write (include your phone number)

Consumer Affairs
General Electric Company
Appliance Park
Louisville, KY 40225

Write down the model and serial numbers.

You'll find them on a label behind the room cabinet above the fan opening.

These numbers are also on the Consumer Product Ownership Registration card that came with your air conditioner. Before sending in this card, please write these numbers here:

Model Number

Serial Number

Use these numbers in any correspondence or service calls concerning your air conditioner.

If you received a damaged air conditioner, immediately contact the dealer (or builder) that sold you the air conditioner.

Save time and money.

Before you request service, check the Problem Solver on page 6. It lists minor causes of operating problems that you can correct yourself.

Important Safety Instructions

Read all instructions before using this appliance.

WARNING—When using this appliance, always exercise basic safety precautions, including the following:

- Use this appliance only for its intended purpose as described in this Use and Care Book.
- This air conditioner must be properly installed in accordance with the Installation Instructions before it is used.
- NEVER USE AN EXTENSION CORD WITH THIS APPLIANCE.

SAVE THESE INSTRUCTIONS

Operating Your Air Conditioner Controls

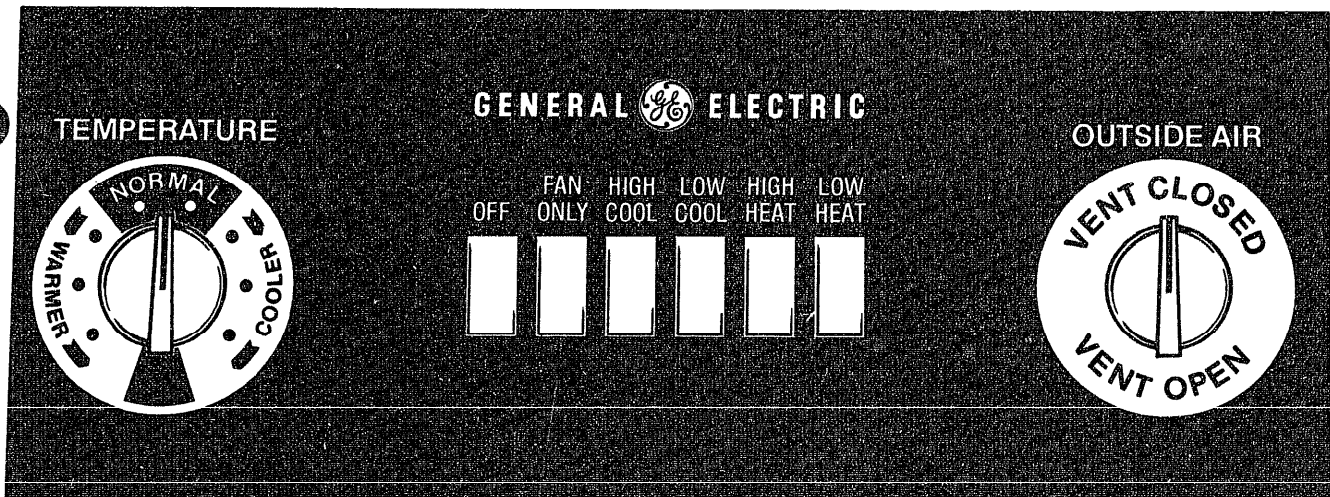

Note: On some models, the far left pushbutton is labeled STOP.

Temperature Control

When you turn the temperature control to the desired setting, the thermostat will automatically control the temperature of the indoor air. A comfortable temperature will be maintained in most rooms when the control is set midway in the normal range. For cooler temperatures, turn the control to the right for warmer temperatures, turn it to the left.

Master Controls

OFF or **STOP** turns air conditioner off.

FAN ONLY permits fan operation without cooling or heating.

HIGH COOL provides high fan speed with maximum cooling and dehumidification.

LOW COOL permits low fan speed with cooling plus maximum dehumidification; affords quieter nighttime operation.

HIGH HEAT produces maximum heating and high fan speed.

LOW HEAT permits heating with low fan speed; affords quieter nighttime operation.

Outside Air Control

When this control is set at **VENT CLOSED**, the vent door is closed and only indoor air is filtered, cooled or heated, and circulated by the air conditioner.

Turning the control to **VENT OPEN** opens the vent door to allow some outside air to enter the room. However, cooling or heating effectiveness is reduced when this control is set at **VENT OPEN**, so we suggest you don't keep it there long.

(continued next page)

Operating Your Air Conditioner Controls (continued)

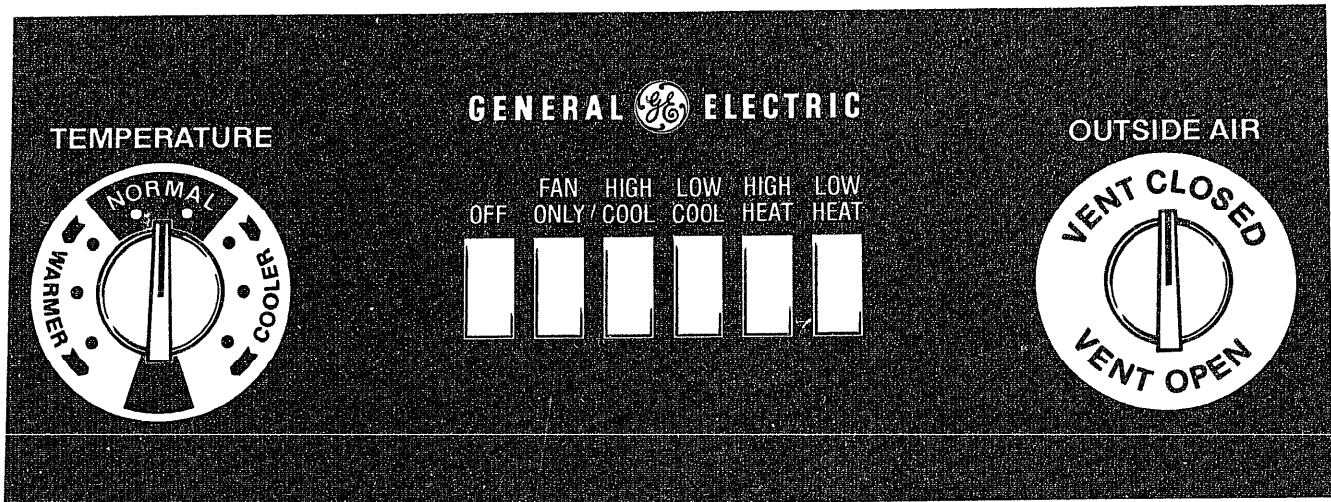

For cooling or heating

1. Set TEMPERATURE CONTROL at desired comfort level (usually midway in the NORMAL range is a good starting position).
2. For cooling, press either the HIGH COOL or LOW COOL pushbutton, depending on the level of cooling desired. For heating, press either the HIGH HEAT or LOW HEAT pushbutton.
3. Set the OUTSIDE AIR control at VENT CLOSED.

For outside air ventilation plus cooling or heating

Follow steps 1 and 2 at left, then set the OUTSIDE AIR control at VENT OPEN.

For outside air ventilation without cooling or heating

1. Press FAN ONLY pushbutton.
2. Set OUTSIDE AIR control at VENT OPEN.

For air circulation and filtering only

1. Press FAN ONLY pushbutton.
2. Set OUTSIDE AIR control at VENT CLOSED.

User Maintenance Instructions

Cleaning your air conditioner

Turn air conditioner off and remove plug from wall receptacle, or remove fuses, or turn off circuit breakers at power panel before cleaning.

If you live in an apartment, your building management may wish to provide these maintenance functions that are necessary for continued peak operating efficiency of your air conditioner.

Room Cabinet & Case

Wash room cabinet and case finish with mild soap or detergent and lukewarm water.

Areas Behind the Room Cabinet

These areas may be vacuumed or wiped with a damp cloth.

Condenser Coils

These coils on the weather side of the unit should be checked periodically and cleaned if clogged with dirt or soot from the atmosphere. If extremely soiled, they may need to be professionally steam cleaned, a service available through your General Electric service outlet.

Air Filter

The foam air filter behind the room cabinet should be washed at least every 30 days or as often as it needs cleaning.

Access to the filter is obtained by tilting the room cabinet out as follows:

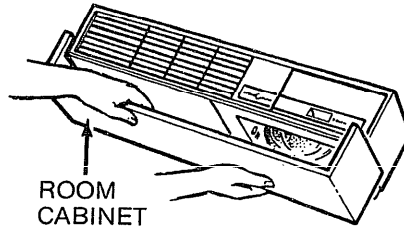

1. Lift, pull and lower.

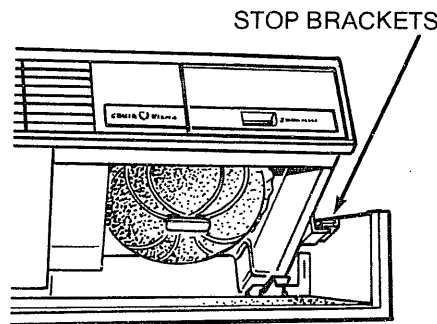

2. Position room cabinet against stop brackets.

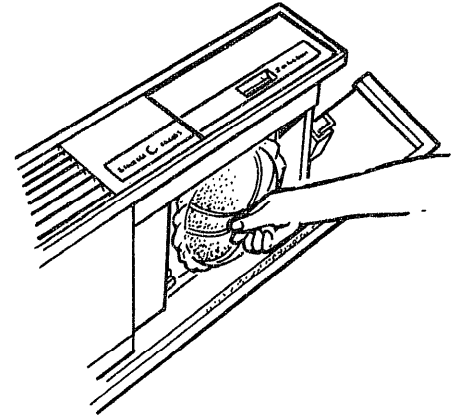

3. Reach in, grasp filter at center tab and pull.

When tilted out, the room cabinet can be removed, if desired, by lifting it so the slots at the bottom of the cabinet disengage from the hooks at the bottom of the chassis.

Note: For Zoneline models installed high in the wall, filter access is through the bottom grille section of the front discharge room cabinet.

Vacuum the filter on the dirty side or wash it with running water. Run water through from the cleaner side of the filter to drive out accumulated dust and lint. Shake to dry. To replace air filter, position the magnetic section of the filter onto the solid center disc portion of the wire blower guard.

Note: The air conditioner should not be operated without an air filter. Replacement filters are available from your General Electric Dealer, Factory Service Center or authorized Customer Care® servicers.

(continued next page)

User Maintenance Instructions (continued)

To replace the room cabinet:

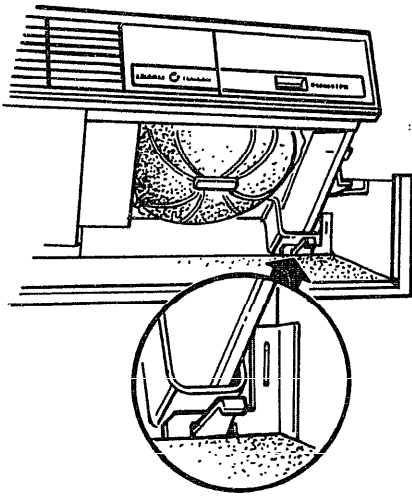

1. Position slots at bottom of room cabinet onto hooks at bottom of chassis.

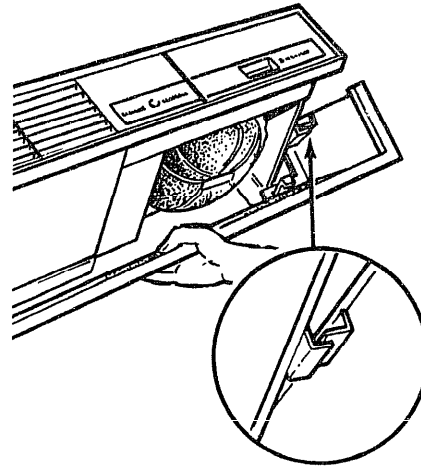

2. Tilt room cabinet inward, lift it and position it so its stops are directly behind the corresponding stops on the chassis.

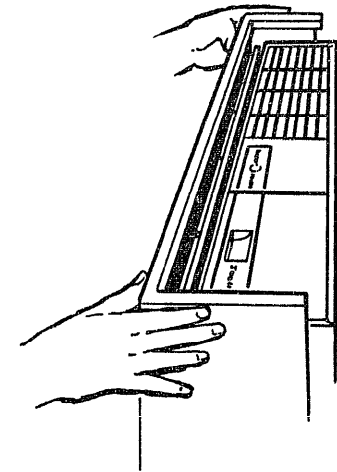

3. Lift the room cabinet, position the top of it onto the front lip of the top air discharge grille, and press it down to secure it.

The Problem Solver

If you have a problem, it may be minor. You may be able to correct it yourself. Just use this Problem Solver to locate your problem and then follow the suggested recommendations.

Save time and money...before you request service, check the following:

PROBLEM	POSSIBLE CAUSE AND REMEDY
AIR CONDITIONER DOES NOT OPERATE	<ul style="list-style-type: none"> • Power cord not plugged in, fuse blown or circuit breaker tripped.
AIR CONDITIONER "DOES NOT COOL OR HEAT AS IT SHOULD"	<ul style="list-style-type: none"> • Curtains, drapes, newspapers, magazines and other items blocking air discharge grille will restrict air flow. • Air filter dirty, should be cleaned at least every 30 days. See instructions on page 5. • Room may have been very hot or very cold when air conditioner was first turned on. Allow time for it to cool down or warm up. • OUTDOOR AIR control may be set at VENT OPEN, allowing outside air to enter the room.
OPERATING SOUNDS	<ul style="list-style-type: none"> • Thermostat click, a metallic sound, may be heard when compressor cycles on and off. This is normal. • Fan runs continuously when FAN ONLY pushbutton is pressed. This is normal. Otherwise, fan cycles on and off with compressor.

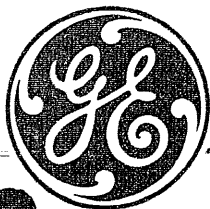

Consumer Services

At General Electric we're committed to providing you with the best appliances we know how to build and we know that you want your appliances to give you many years of dependable service.

Our Consumer Services are designed with your needs and wants in mind.

1.

Warranty Protection

Your new appliance is a well designed and engineered product. Before it left the factory, it went through rigorous tests to detect manufacturing defects. And you have a written warranty to protect you.

See the warranty on the back page of this book for details.

2.

Prompt Service at your Convenience

Whether your appliance is in or out of warranty, you're just a phone call away from our nationwide network of Factory Trained Service professionals.

Simply call our GE service organization. You'll find them in the White Pages under "General Electric Company" or "General Electric Factory Service," and in the Yellow Pages under "General Electric Customer Care® Service."

Service is scheduled at your convenience and the technician drives a fully-stocked parts service truck so that, in most cases, the repair can be completed in one visit.

We're proud of our service and want you to be pleased, but if for some reason you are not happy with the service you receive, here are three steps to follow for further help.

FIRST, contact the people who serviced your appliance. Explain why you are not pleased. In most cases, this will solve the problem.

NEXT, if you are still not pleased write all the details — including your phone number to:

Manager, Consumer Relations
General Electric Company
Appliance Park
Louisville, Kentucky 40225

FINALLY, if your problem is still not resolved, write:

Major Appliance Consumer Action Panel
20 North Wacker Drive
Chicago, Illinois 60606

3.

Service Contracts

For trouble-free service beyond the written warranty period.

If you prefer to budget your repair expenditures instead of being surprised by them, GE offers service contracts for varying lengths of time on all GE major appliances. With a contract, we'll

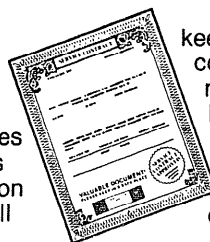

keep your appliance in good operating condition during the contract period at no additional charge. Service contracts let you pay today's prices for service a month, a year, or several years from now. And, you'll receive service from GE trained service technicians using only Genuine GE parts.

4.

The Quick Fix® System You can save money and time by doing it yourself.

For do-it-yourselfers who would prefer to fix GE major appliances themselves...GE offers an industry first, the Quick Fix® System.

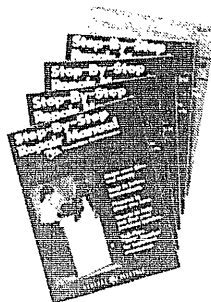

A program for do-it-yourself appliance repair, the system includes *step-by-step repair manuals* for refrigerators, most non-microwave electric ranges, dishwashers, and standard and large capacity washers and dryers, plus *specialty packaged replacement parts*, and technical help with a *toll-free 800 number*.

5.

Help for You by Phone

Should you need help in the selection and purchase of new appliances, or have questions about the operation of the GE appliances you now own—or have any other questions about our consumer products or services, you are only a *TOLL-FREE* call away.

The GE Answer Center™ 800.626.2000 consumer information service is open 24 hours a day, seven days a week.

Our staff of experts stands ready to assist you anytime.



YOUR GENERAL ELECTRIC ROOM AIR CONDITIONER

WARRANTY

Save proof of original purchase date such as your sales slip or cancelled check to establish warranty period.

WHAT IS COVERED

FULL ONE-YEAR WARRANTY

For one year from date of original purchase, we will provide, free of charge, parts and service labor in your home to repair or replace **any part of the room air conditioner** that fails because of a manufacturing defect.

FULL FIVE-YEAR WARRANTY

For five years from date of original purchase, we will provide, free of charge, a replacement compressor and service labor to diagnose and replace **any compressor** that fails because of a manufacturing defect.

For each of the above warranties: Transportation expense to and from a service shop and shop service labor if required will be free of charge.

This warranty is extended to the original purchaser and any succeeding owner for products purchased for use in the 48 mainland states, Hawaii and Washington, D.C. In Alaska the warranty is the same except that it is LIMITED because you must pay to ship the product to the service shop or for the service technicians travel costs to your home.

All warranty service will be provided by our Factory Service Centers or by our authorized Customer Care® servicers during normal working hours.

Look in the White or Yellow Pages of your telephone directory for GENERAL ELECTRIC COMPANY, GENERAL ELECTRIC FACTORY SERVICE, GENERAL ELECTRIC-HOTPOINT FACTORY SERVICE or GENERAL ELECTRIC CUSTOMER CARE® SERVICE.

WHAT IS NOT COVERED

- Service trips to your home to teach you how to use the product.

Read your Use and Care material.

If you then have any questions about operating the product, please contact your dealer or our Consumer Affairs office at the address below, or call, toll free:

The GE Answer Center™
800.626.2000
consumer information service

- Improper installation.

If you have an installation problem or if the air conditioner is of improper cooling or heating capacity for the intended use contact your dealer or installer. You are responsible for providing adequate electrical connecting facilities.

- Replacement of house fuses or resetting of circuit breakers.

- In commercial locations labor necessary to move the unit to a location where it is accessible for service by an individual technician.

- Failure of the product resulting from modifications to the product or due to unreasonable use including failure to provide reasonable and necessary maintenance.

- Damage to the product caused by improper power supply voltage, accident, fire, floods or acts of God.

WARRANTOR IS NOT RESPONSIBLE FOR CONSEQUENTIAL DAMAGES.

Some states do not allow the exclusion or limitation of incidental or consequential damages, so the above limitation or exclusion may not apply to you. This warranty gives you specific legal rights, and you may also have other rights which vary from state to state. To know what your legal rights are in your state, consult your local or state consumer affairs office or your state's Attorney General.

Warrantor: General Electric Company

If further help is needed concerning this warranty, contact:

Manager—Consumer Affairs, General Electric Company, Appliance Park, Louisville, KY 40225