

# Installation

## IMPORTANT!

### Please read this instruction sheet completely before installing the product.

This air conditioning system meets strict safety and operating standards. As the installer or service person, it is an important part of your job to install or service the system so it operates safely and efficiently.

#### WARNING

- Installation or repairs made by unqualified persons can result in hazards to you and others. Installation MUST conform with local building codes or, in the absence of local codes, with the National Electrical Code NFPA 70/ANSI C1-1993 or current edition and Canadian Electrical Code Part 1 CSA C.22.1.
- The information contained in the manual is intended for use by a qualified service technician familiar with safety procedures and equipped with the proper tools and test instruments.
- Failure to carefully read and follow all instructions in this manual can result in equipment malfunction, property damage, personal injury and/or death.

**CAUTION:** Improper installation, adjustment, alteration, service or maintenance can void the warranty.

The weight of the condensing unit requires caution and proper handling procedures when lifting or moving to avoid personal injury. Use care to avoid contact with sharp or pointed edges.

#### Safety Precautions

- Always wear safety eye wear and work gloves when installing equipment.
- Never assume electrical power is disconnected. Check with meter and equipment.
- Keep hands out of fan areas when power is connected to equipment.
- R-22 causes frostbite burns.
- R-22 is toxic when burned.

**NOTE TO INSTALLING DEALER:** The Owners Instructions and Warranty are to be given to the owner or prominently displayed near the indoor Furnace/Air Handler Unit.

#### Special warnings

##### When wiring:

**Electrical shock can cause severe personal injury or death. Only a qualified, experienced electrician should attempt to wire this system.**

- Do not supply power to the unit until all wiring and tubing are completed or reconnected and checked.
- Highly dangerous electrical voltages are used in this system. Carefully refer to the wiring diagram and these instructions when wiring. Improper connections and inadequate grounding can cause accidental injury or death.
- Ground the unit following local electrical codes.
- Connect all wiring tightly. Loose wiring may cause overheating at connection points and a possible fire hazard.

##### When transporting:

Be careful when picking up and moving the indoor and outdoor units. Get a partner to help, and bend your knees when lifting to reduce strain on your back. Sharp edges or thin aluminum fins on the air conditioner can cut your finger.

##### When installing...

... **in a wall:** Make sure the wall is strong enough to hold the unit's weight.

It may be necessary to construct a strong wood or metal frame to provide added support.

... **in a room:** Properly insulate any tubing run inside a room to prevent "sweating" that can cause dripping and water damage to wall and floors.

... **in moist or uneven locations:** Use a raised concrete pad or concrete blocks provide a solid, level foundation for the outdoor unit. This prevents water damage and abnormal vibration.

... **in an area with high winds:** Securely anchor the outdoor unit down with bolts and a metal frame. Provide a suitable air baffle.

... **in a snowy area(for Heat Pump Model):** Install the outdoor unit on a raised platform that is higher than drifting snow. Provide snow vents.

##### When connecting refrigerant tubing

- Keep all tubing runs as short as possible.
- Use the flare method for connecting tubing.
- Check carefully for leaks before starting the test run.

##### When servicing

- Turn the power OFF at the main power box(mains) before opening the unit to check or repair electrical parts and wiring.
- Keep your fingers and clothing away from any moving parts.
- Clean up the site after you finish, remembering to check that no metal scraps or bits of wiring have been left inside the unit being serviced.

## (1) Installation Parts Provided

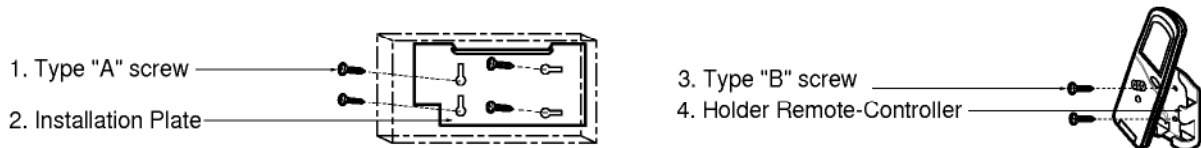

## (2) Installation of Indoor, Outdoor unit

### 1) Selection of the best location

#### 1. Indoor unit.

- There should not be any heat source or steam near the unit.
- There should not be any obstacles to prevent the air circulation.
- A place where air circulation in the room will be good.
- A place where drainage can be easily obtained.
- A place where noise prevention is taken into consideration.
- Do not install the unit near the door way.
- Ensure the spaces indicated by arrows from the wall, ceiling, fence, or other obstacles.

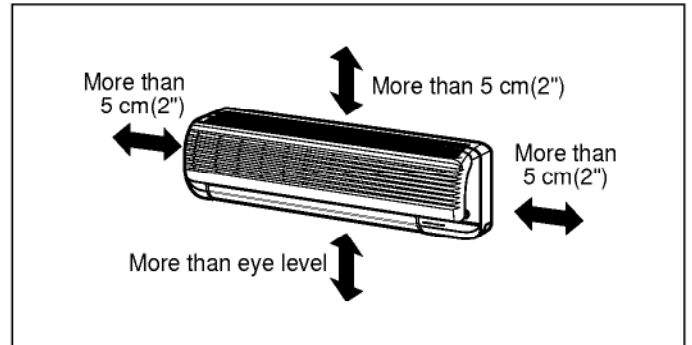

#### 2. Outdoor unit

- If an awning is built over the unit to prevent direct sunlight or rain exposure, be careful that heat radiation from the condenser is not restricted.
- There should not be any animals or plants which could be affected by hot air discharged.
- Ensure the spaces indicated by arrows from the wall, ceiling, fence, or other obstacles.

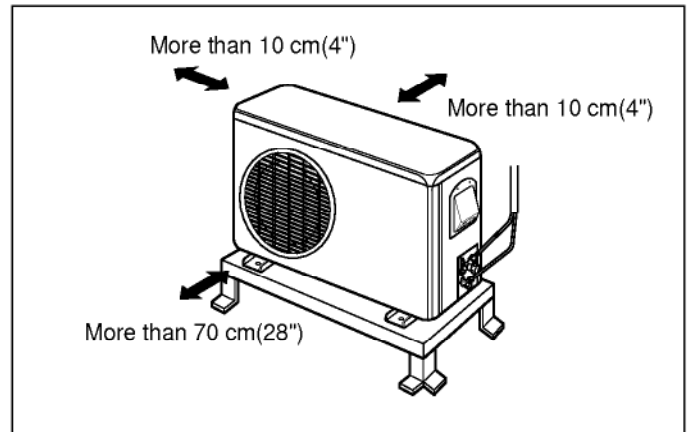

### Roof Top Installations

If it is necessary to install units on a roof structure, be sure to elevate and level the units. Ensure the roof structure and anchoring method are adequate for unit location. Consult local codes regarding rooftop mounting.

**NOTE:** When condensing unit is to be installed on a bonded guaranteed roof, a release must be obtained from the building owner to free the installer from all liabilities.

### 3. Piping length and the elevation

MODEL (Cooling Capa.)	Pipe Size		Max. length A	Max. Elevation B
	GAS	LIQUID		
12K	1/2"	1/4"	15m(50ft)	8m(26ft)
18K, 24K	5/8"	3/8"	15m(50ft)	8m(26ft)

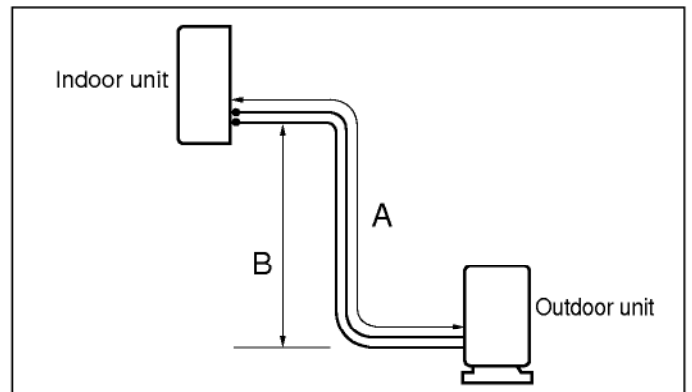

## 2) Indoor Unit Installation

The mounting wall should be strong and solid enough to protect it from the vibration.

### 1. Mount the installation plate on the wall with four Type "A" screws.

(if mounting the unit on the concrete wall, consider using anchor bolts.)

- Always mount the Installation Plate horizontally by aligning the marking-off line by means of the thread and a level.

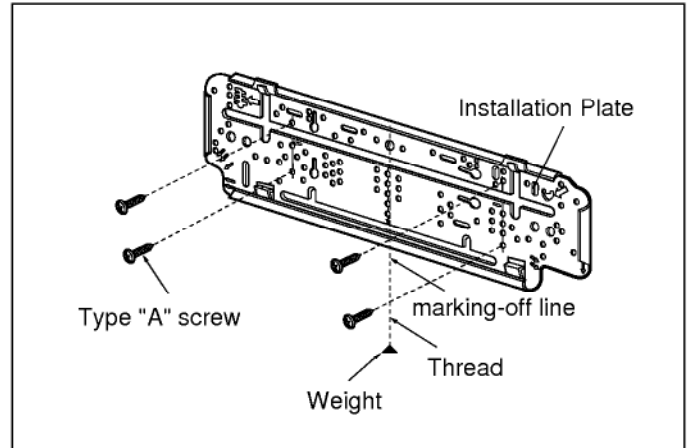

### 2. Drill the piping hole with 70mm(2.75") dia. holecore drill.

- Drill the Piping hole at either the right or the left and the hole should be slightly slanted to the outdoor side.

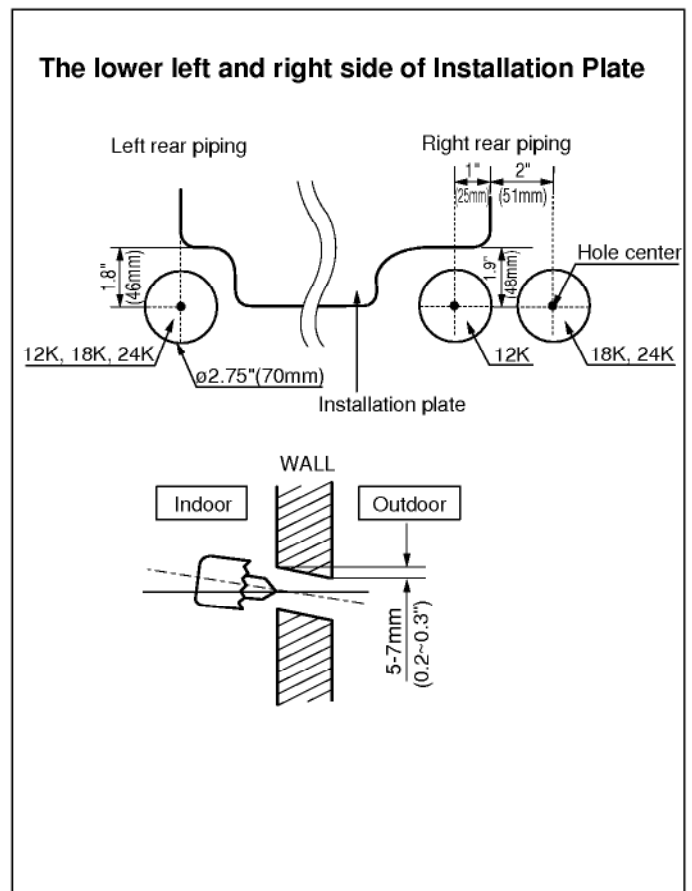

### WARNING

Avoid areas where electrical wiring, conduits or gas lines are located. Accidentally cutting a live wire or gas line can cause death or injury.

### (3) Piping and Drainage of Indoor Unit

#### 1) PREPARATION OF PIPINGS

##### 1. Cut the pipes and the cable.

- Use the pipes purchased locally.
- Measure the distance between the indoor and the outdoor unit.
- Cut the pipes a little longer than measured distance.
- Cut the cable 1.5m(5.0 ft) longer than the length of the pipe.

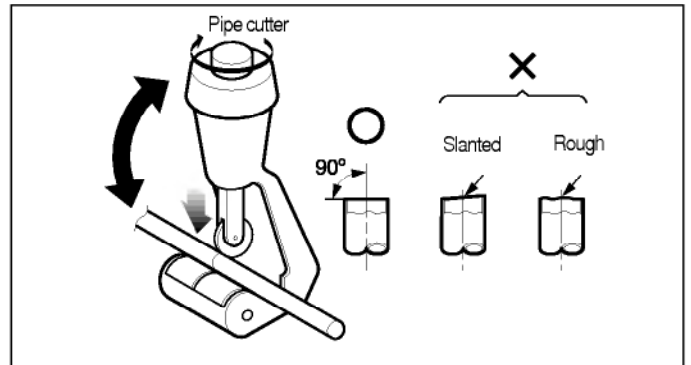

##### 2. Remove burrs.

- Remove burrs from cut edges of pipes.
- Turn the pipe end toward down to avoid the metal powder entering the pipe.

##### Caution:

If burrs are not removed, they may cause a gas leakage.

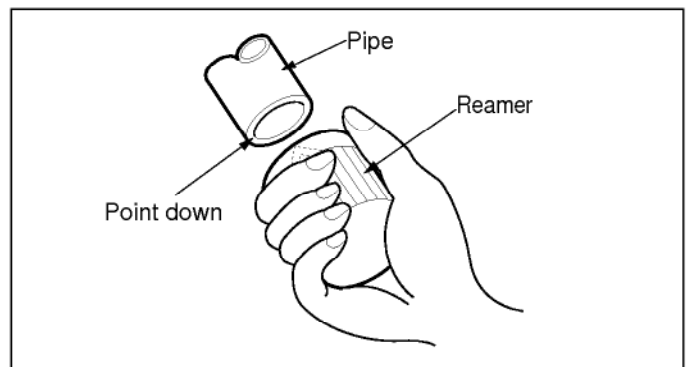

##### 3. Flaring the pipes.

- Insert the flare nuts, mounted on the connection ports of both indoor and outdoor unit, onto the copper pipes. Some gas may leak, when the flare nuts are removed from the indoor unit, as some gas is charged to prevent the inside of the pipe from rusting.
- Fit the copper pipe end into the Bar of flare tool about 0.5~1.0mm higher. (See illustration)
- Make a flare at the end of copper pipe with a flare tool\*.

\* Use "RIDGID" or equivalent.

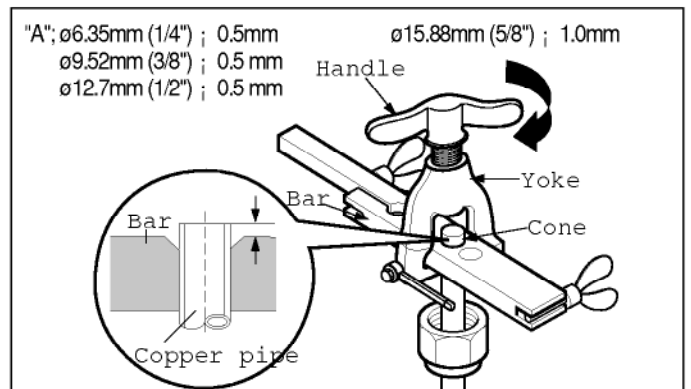

##### 4. Tape the flaring portion to protect it from the dust or damages.

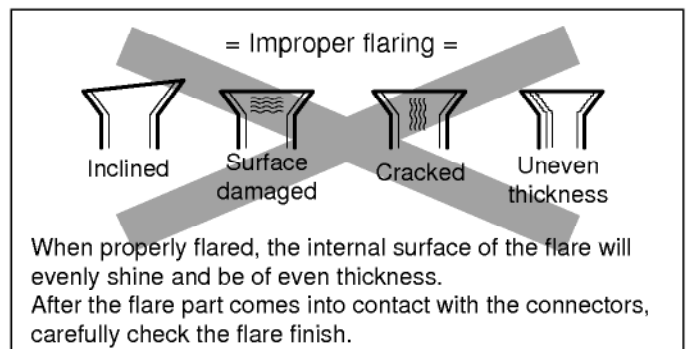

## 2) Connection of Pippings

### 1. Remove the indoor tubing with Drain hose from the hole

- Remove tubing holder and pull the tubing out of the chassis.

### 2. Replace the tubing holder into original position.

- Recommended SPEC. of a additional Drain Hose.

Joint Part		The material of Drain hose
Inner size	Material	
MAX. ø16mm(5/8")	soft PVC	Soft PVC hose (It must be surrounded with an Insulation Material*)

- \* Foamed Polyethylene or equivalent is recommended.

CAUTION: The unit's drain hose and additional drain hose must be sealed up by adhesive or tape.

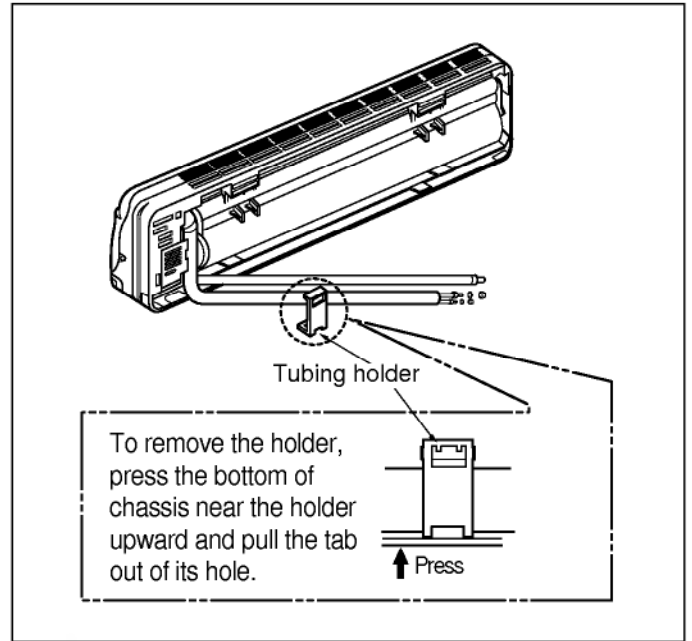

### For right rear piping

### 3. Route the tubing and the drain hose straight backwards.

### 4. Insert the connecting cable into the indoor unit through the piping hole.

- Do not connect the cable to the indoor unit.
- Make a small loop with the cable for easy connection later.

### 5. Tape the tubing, drain hose and the connecting cable. Be sure that drain hose locates at the lowest side of the bundle. Locating at the upper side can be a reason that drain water overflows drain pan inside the unit.

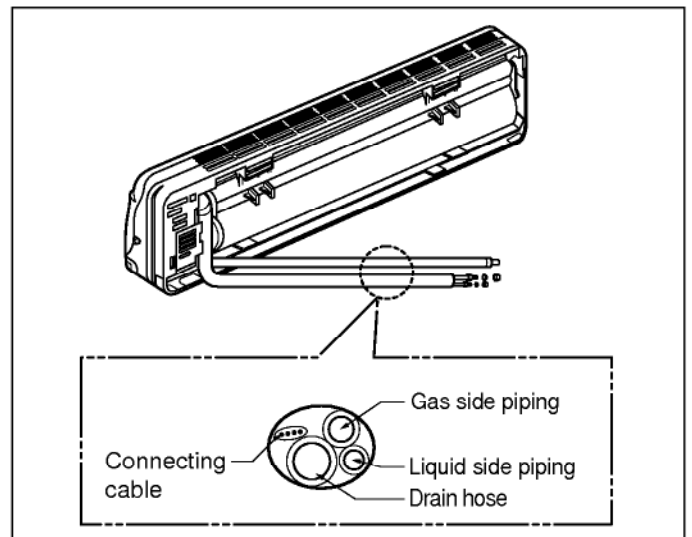

### NOTE

If the drain hose will run in the room, insulate the hose with an insulation material\* so that dripping from "sweating"(condensation) will not damage furniture or floors.

- \* Foamed polyethylene or equivalent is recommended.

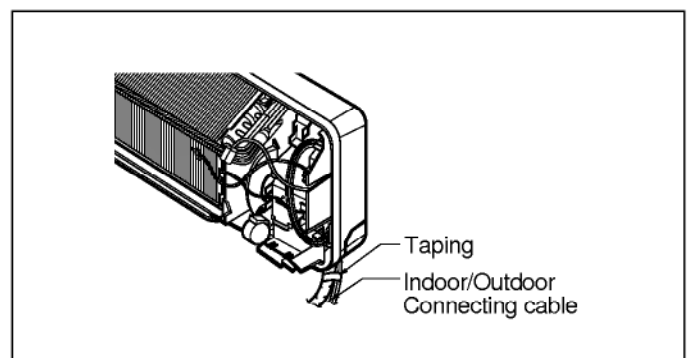

## 6. Indoor unit installation

- Hook the indoor unit onto the upper portion of installation plate. (Engage the two hooks of the rear top of the indoor unit with the upper edge of the installation plate.)  
Ensure the hooks are properly seated on the installation plate by moving it left and right.

## 7. Connecting the pipings to the indoor unit.

- Align the center of the pipings and sufficiently tighten the flare nut with fingers.
- Finally, tighten the flare nut with torque wrench until the wrench clicks.  
When tightening the flare nut with torque wrench, ensure the direction for tightening follows the arrow on the wrench.

Pipe Size		Torque
12K	Liquid Side (1/4")	1.8kg <sub>m</sub> (13ft.lbs)
	Gas Side (1/2")	5.5kg <sub>m</sub> (39.8ft.lbs)
18K, 24K	Liquid Side (3/8")	4.0kg <sub>m</sub> (28.9ft.lbs)
	Gas Side (5/8")	6.6kg <sub>m</sub> (47.7ft.lbs)

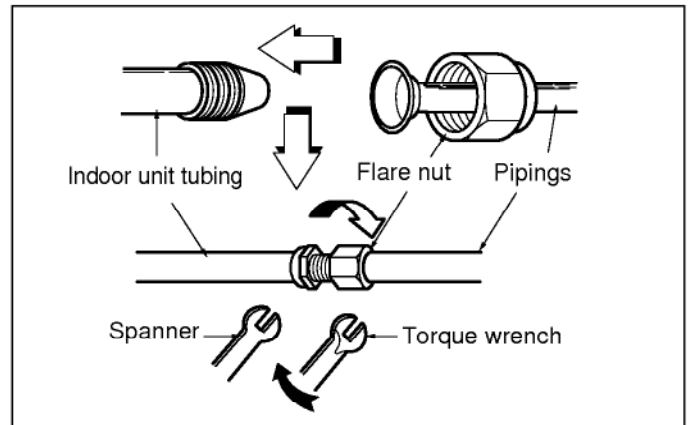
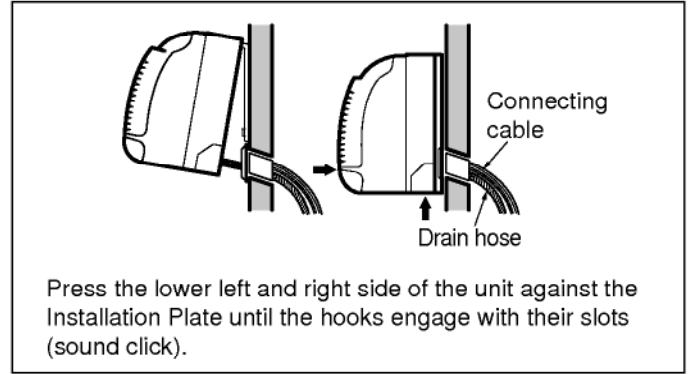

## 8. Wrap the insulation material around the connecting portion.

**CAUTION:** Take care to arrange the pipings, drain hose and cables as the picture on page 25 for inserting it into the indoor unit and refixing the tubing holder easily.

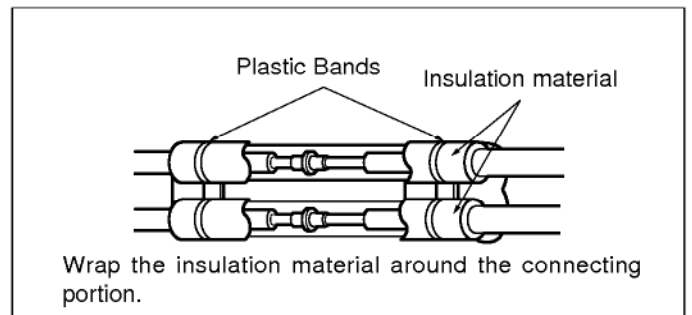

## 9. Insulation of connecting tubing

- Because capillary tubing is installed in the outdoor unit, both the liquid and gas side tubes of this air conditioner become cold or hot(Heat pump model). Therefore, to prevent heat loss and wet floors due to dripping of condensation water, both tubes must be well insulated with proper insulation material. The thickness of the insulation material should be a Min. 8mm(5/16").

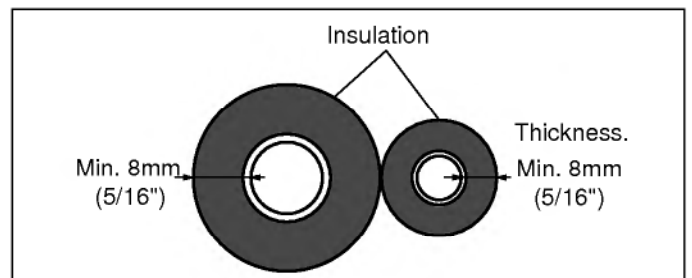

**For Heat pump model, Heat-resistant insulation material enduring at 230°F should be used.**

**For the left pipings**

3. Route the indoor tubing with the drain hose to the piping hole as desired position.

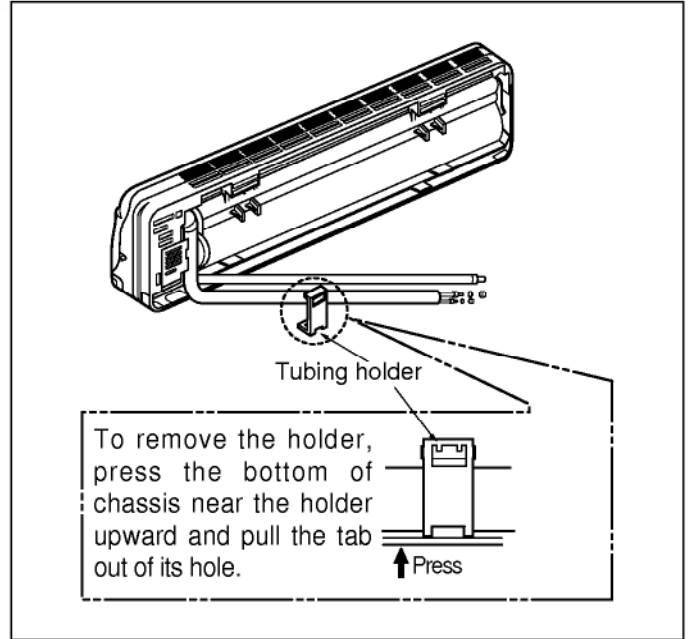

4. Insert the pipings, power supply cord and connecting cable into the piping hole.

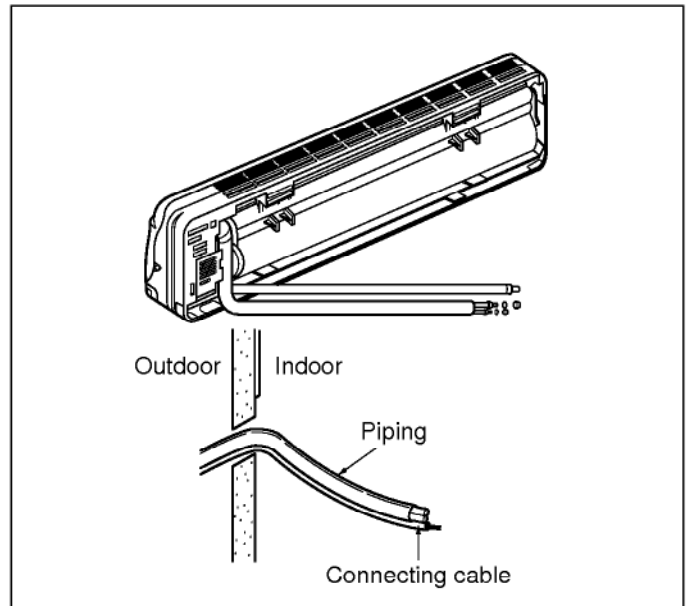

**5. Insert the connecting cable into the indoor unit.**

- Don't connect the cable to the indoor unit.
- Make a small loop with the cable for easy connection later.

**6. Tape the tubing, drain hose and the connecting cable.**

**7. Indoor unit installation**

- Hook the indoor unit onto the upper portion of installation plate. (Engage the two hooks of the rear top of the indoor unit with the upper edge of the installation plate.) Ensure the hooks are properly seated on the installation plate by moving it in left and right.

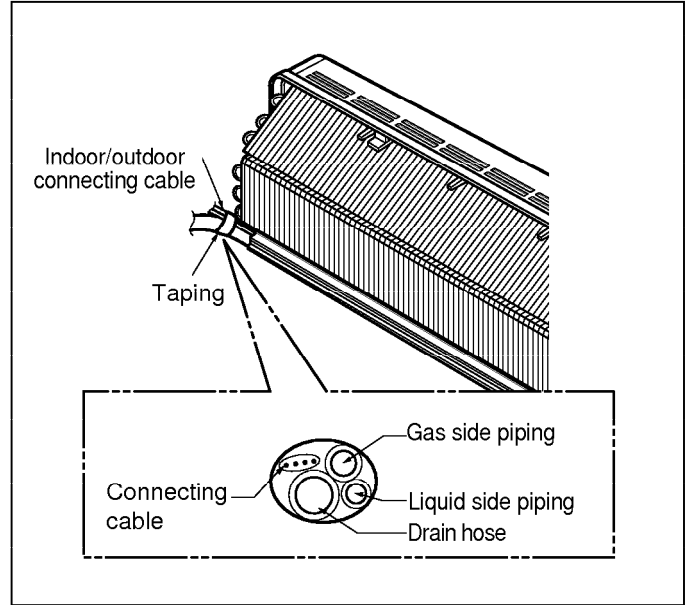

**8. Connecting the pipings to the indoor unit.**

- Align the center of the pipings and sufficiently tighten the flare nut with fingers.
- Finally, tighten the flare nut with torque wrench until the wrench clicks. When tightening the flare nut with torque wrench, ensure the direction for tightening follows the arrow on the wrench.

	Pipe Size	Torque
12K	Liquid Side (1/4")	1.8kg <sub>i</sub> ·m(13ft.lbs)
	Gas Side (1/2")	5.5kg <sub>i</sub> ·m(39.8ft.lbs)
18K,	Liquid Side (3/8")	4.0kg <sub>i</sub> ·m(28.9ft.lbs)
24K	Gas Side (5/8")	6.6kg <sub>i</sub> ·m(47.7ft.lbs)

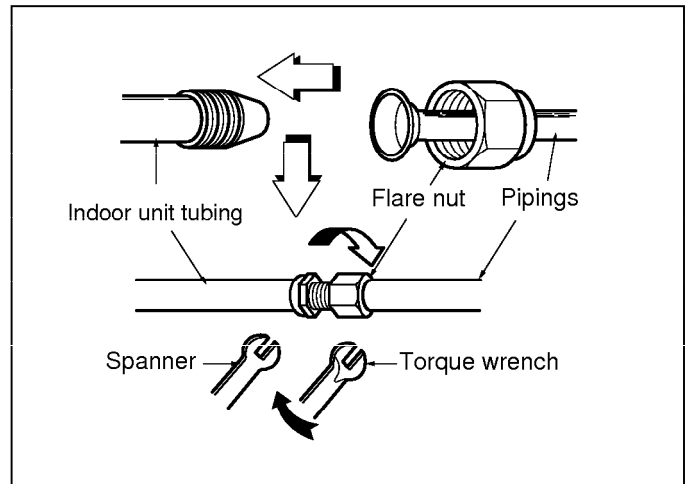

**9. Wrap the insulation material around the connecting portion.**

**CAUTION:** Take care to arrange the pipings, drain hose and cables as the right upper picture for inserting it into the indoor unit and refixing the tubing holder easily.

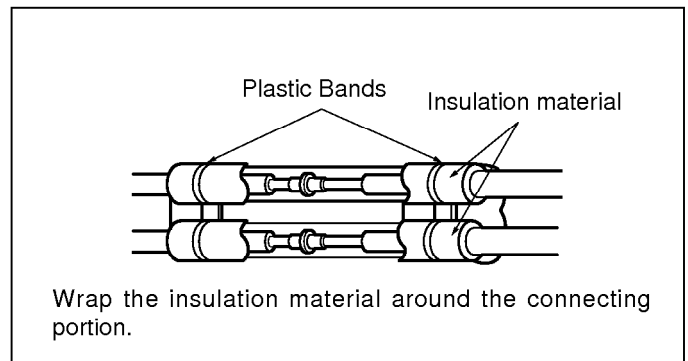



**10. Set the pipings and the connecting cable to the back of the chassis with the tubing holder**

- Hook the edge of tubing holder to tap on chassis and push the bottom of tubing holder to be engaged in the bottom of chassis.

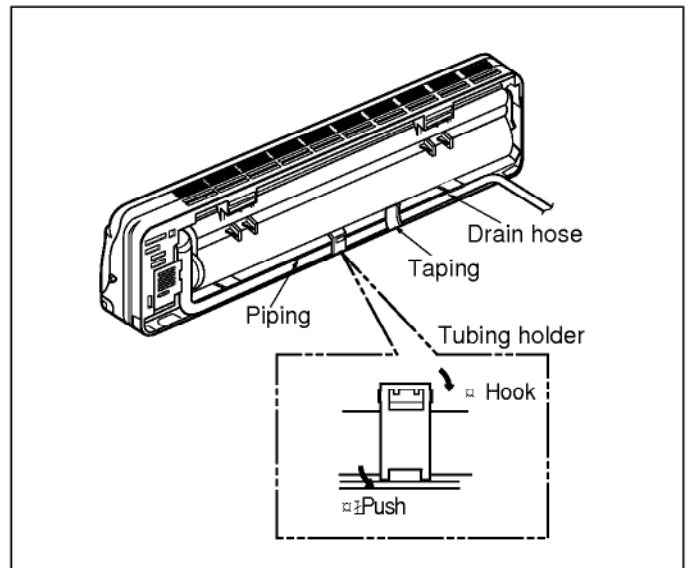
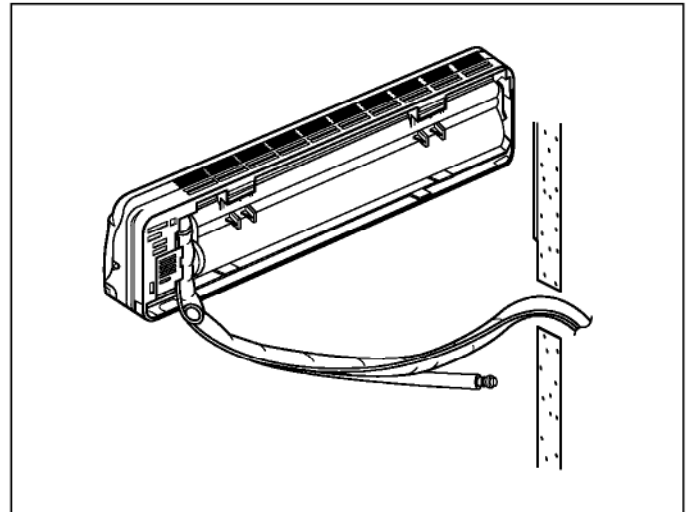

**11. Indoor unit installation**

- Hook the indoor unit onto the upper portion of installation plate. (Engage the two hooks of the rear top of the indoor unit with the upper edge of the installation plate.)  
Ensure the hooks are properly seated on the installation plate by moving it in left and right.

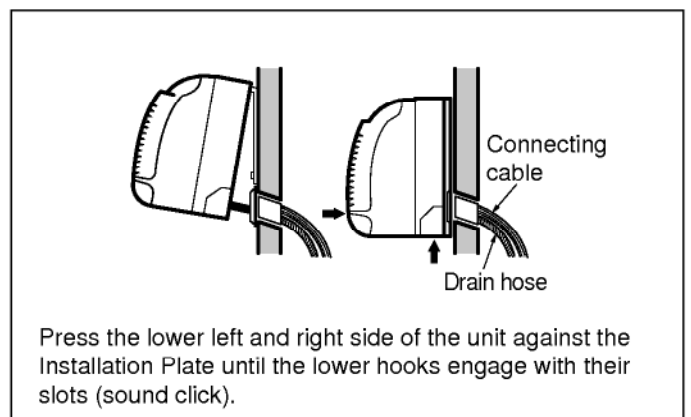

## (4) Connecting Pipings and the cable to Outdoor unit

### 1) Connecting the pipings to the Outdoor unit

1. Align the center of the pipings and sufficiently tighten the flare nut with fingers.
2. Finally, tighten the flare nut with torque wrench until the wrench clicks.
  - When tightening the flare nut with torque wrench, ensure the direction for tightening follows the arrow on the wrench.

Pipe Size		Torque
12K	Liquid Side (1/4")	1.8kg·m(13ft.lbs)
	Gas Side (1/2")	5.5kg·m(39.8ft.lbs)
18K, 24K	Liquid Side (3/8")	4.0kg·m(28.9ft.lbs)
	Gas Side (5/8")	6.6kg·m(47.7ft.lbs)

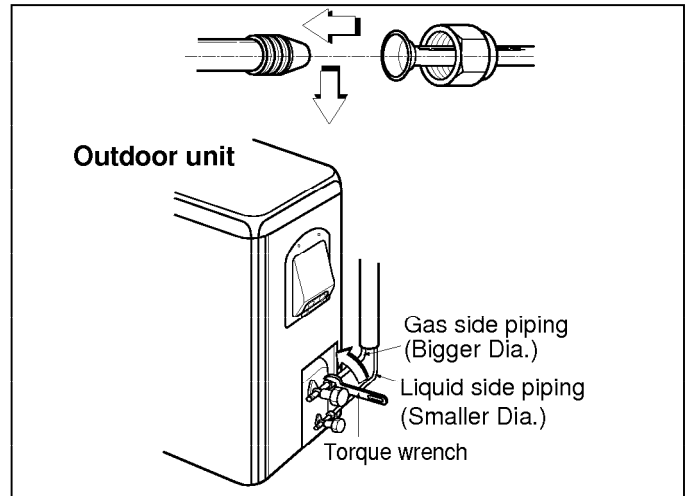

### 2) Connection of the cable

1. Remove the cover control from the unit by loosening the 3 screws.
2. Dismount caps on the conduit panel.
3. Temporarily mount the conduit tubes on the conduit panel.
4. Properly connect both the power supply and low voltage lines to the corresponding terminals on the terminal block.
5. Ground the unit in accordance with local codes.
6. Be sure to size each wire allowing several inches longer than the required length for wiring.
7. Use lock nuts to secure the conduit tubes.

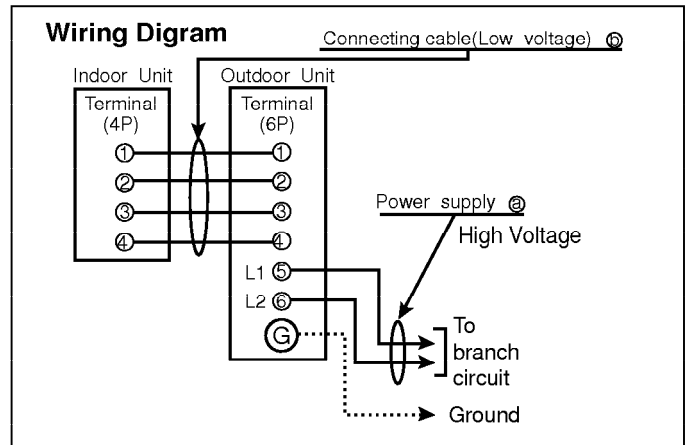

#### NOTE

Connector trade size for this unit is 1/2". Refer to "How to connect wiring to the terminals" for instructions on connecting depending on the wire type you are using.



#### WARNING

- Be sure to comply with local codes while running the wire from the indoor unit to the outdoor unit (size of wire and wiring method, etc).
- Every wire must be connected firmly.
- No wire should be allowed to touch refrigerant tubing, the compressor or any moving parts.

#### Power Supply

Model	Power source	AWG(MIN.)		Fuse or breaker Capacity
		□"	□"	
12K	1φ, 230/208V	14	18	15A
18K	1φ, 230/208V	14	18	15A
24K	1φ, 230/208V	14	18	20A

#### NOTE

1. shows field wiring.
2. Separately wire the high and low voltage line.
3. Use heat-proof electrical wiring capable of withstanding temperatures up to 167°F.
4. Use outdoor and waterproof connection cable rated more than 300V for the connection between indoor and outdoor unit. (For example, Type SJO-WA)

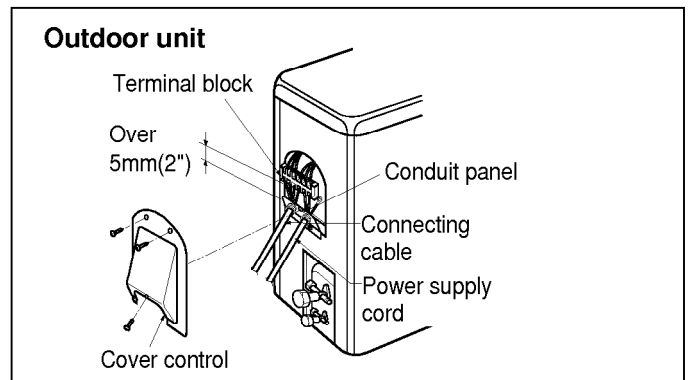

## Connection method of the connecting cable(Example)

- (1) Dismount two-caps on the conduit panel.
- (2) Make a hole appropriate for the passage of connection cable through on cap by tool.  
(for low voltage line)
- (3) Pass the connecting cable through the hole.
- (4) Properly connect the cable on the terminal block.
- (5) Fix the connection cable with clamp cord provided on the unit not to have strain at the terminal when the connection cable is pulled outside up to a 35 pound weight.
- (6) Wind the vinyl tape round the connecting cable for sealing between the surface of the connection cable and cap.
- (7) Mount the taped part of cable on the cap.
- (8) Finally, mount the holed cap with the wound cable on the conduit panel.

### **WARNING**

Loose wiring may cause the terminal to overheat or result in unit malfunction. A fire hazard may also exist. Therefore, be sure all wiring is tightly connected.

When connecting each power wire to the corresponding terminal, follow instructions "How to connect wiring to the terminals" and fasten the wire tightly with the fixing screw of the terminal plate.

### How to connect wiring to the terminals

#### § For solid core wiring (or F-cable)

- (1) Cut the wire end with a wire cutter or wire-cutting pliers, then strip the insulation to expose the solid wire about 25mm(15/16")
- (2) Using a screwdriver, remove the terminal screw(s) on the terminal plate.
- (3) Using pliers, bend the solid wire to form a loop suitable for the terminal screw.
- (4) Shape the loop wire properly, place it on the terminal plate and tighten securely with the terminal screw using a screwdriver.

#### § For strand wiring

- (1) Cut the wire end with a wire cutter or wire-cutting pliers, then strip the insulation to expose the strand wiring about 10mm(3/8").
- (2) Using a screwdriver, remove the terminal screw(s) on the terminal plate.
- (3) Using a round terminal fastener or pliers, securely clamp each stripped wire end with a round terminal.
- (4) Position the round terminal wire, and replace and tighten the terminal screw using a screwdriver.

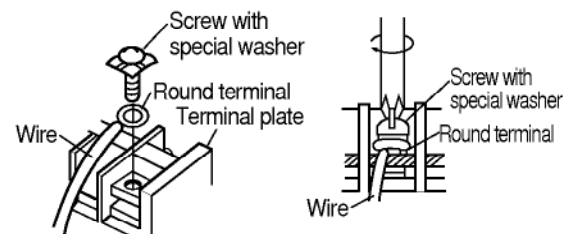
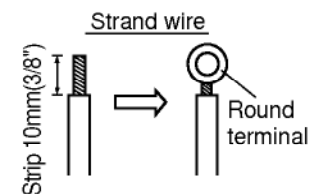
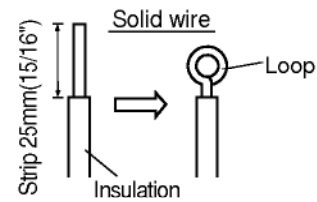
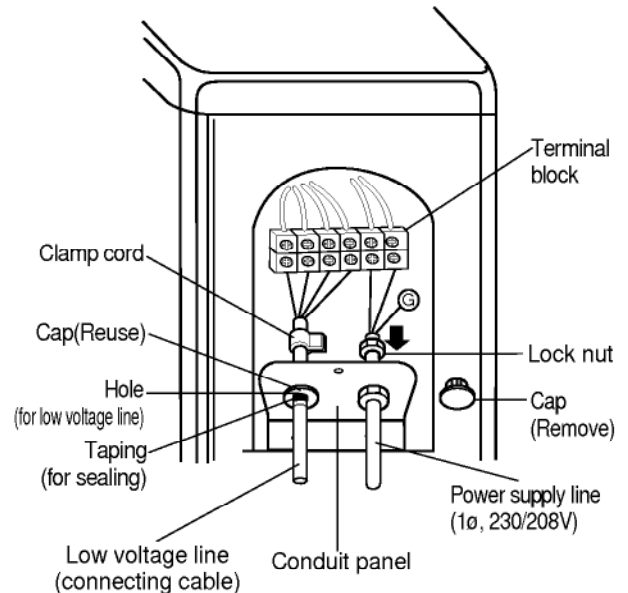

## (5) Checking the Drainage and Connecting the cable to Indoor unit

### 1) Checking the Drainage

#### 1. Remove the Grille from the cabinet.

- Set the up-and-down air direction louver to open position (horizontally) by finger pressure.
- Remove 3 screws.
- To remove the Grille, pull lower the left and right side of the grille toward you (slightly tilted) and lift it straight upward (Four tabs on the top inside edge of chassis are clear of their slots).

#### NOTE

- Outside drain hose should be lower than inside.
- The end of drain hose should not come in touch with surface of land.
- The end of drain hose should not dip into sewer or water.

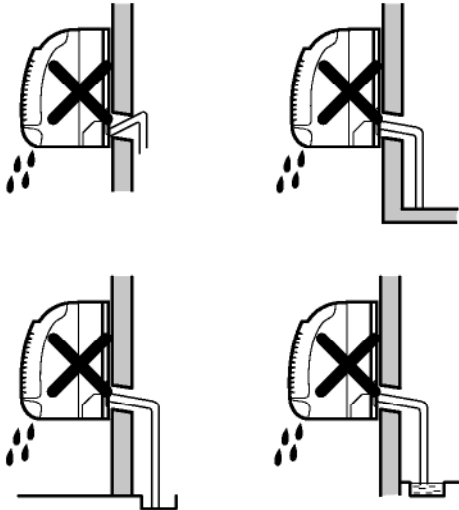

#### 2. Check the drainage.

- Pour a glass of water on the evaporator.
- Ensure if water flows drain hose of indoor unit without any leakage.

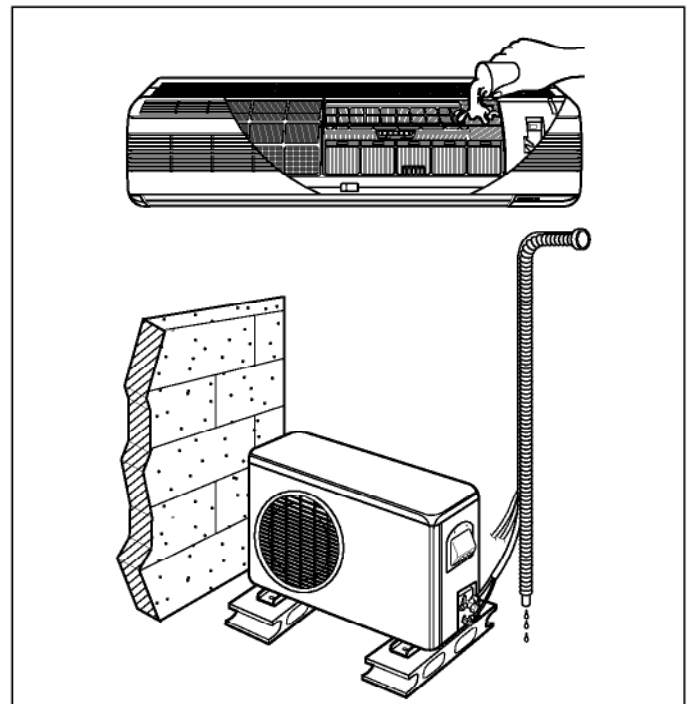
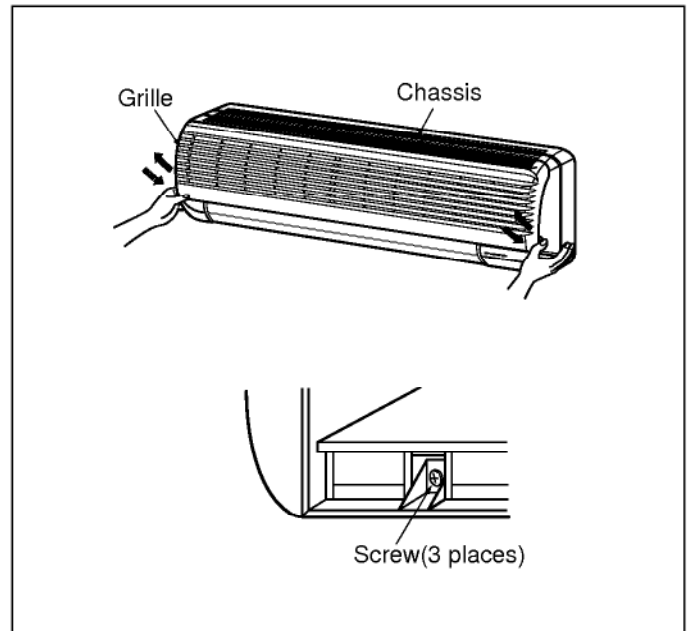

## 2) Connect the cable to the indoor unit

### 1. Connect the wires to the terminals on the control board individually according to the outdoor unit connection.

- Ensure that the color of the wires of outdoor unit and the terminal No. are the same as those of indoor unit respectively.  
(Refer to Wiring diagram on page30.)

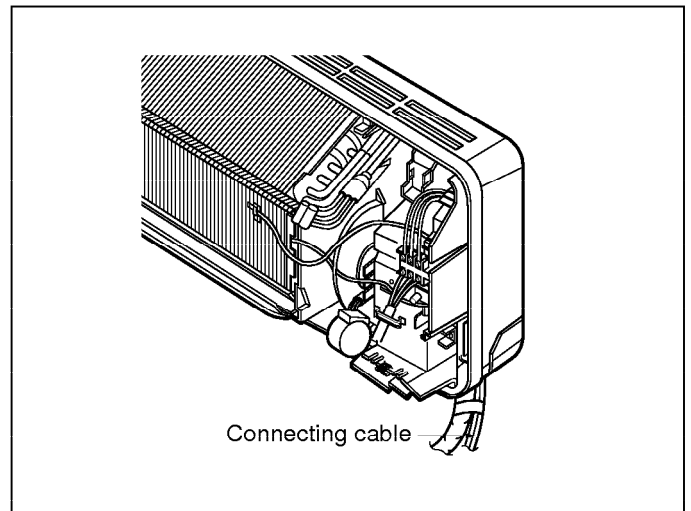

### WARNING

- Be sure to refer to the wiring diagram label inside the cover control and carry out the correct field wiring.  
Wrong wiring can cause the unit to misoperate to result in a fire hazard.
- Check local electrical codes and any specified wiring instructions or limitations.

### 2. Attach the Grille onto the cabinet.

- Grasp lower the left and right side of the Grille and engage four tabs on the top inside edge of the chassis.
- Press the Grille toward the chassis until it will be back into place.

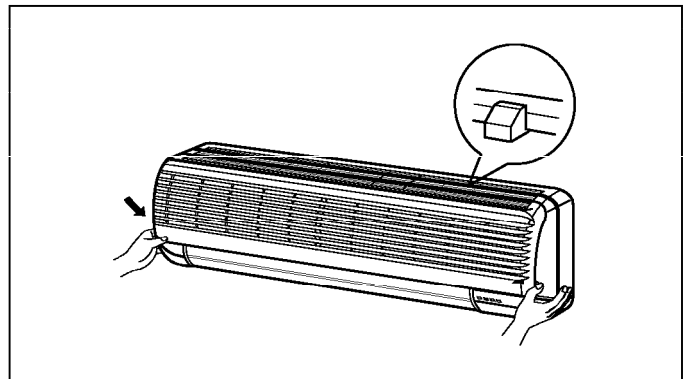

### 3) Forming the pipings

#### 1. Wrap the connecting portion of indoor unit with the Insulation material and secure it with two Plastic Bands.(for the right pipings)

- If you want to connect an additional drain hose, the end of the drain-outlet should keep distance from the ground.(Do not dip it into water, and fix it on the wall to avoid swinging in the wind.)

In case of the Outdoor unit being installed below position of the Indoor unit.

#### 2. Tape the Pipings, drain hose and Connecting Cable from down to up.

#### 3. Form the pipings gathered by taping along the exterior wall and fix it onto the wall by saddle or equivalent.

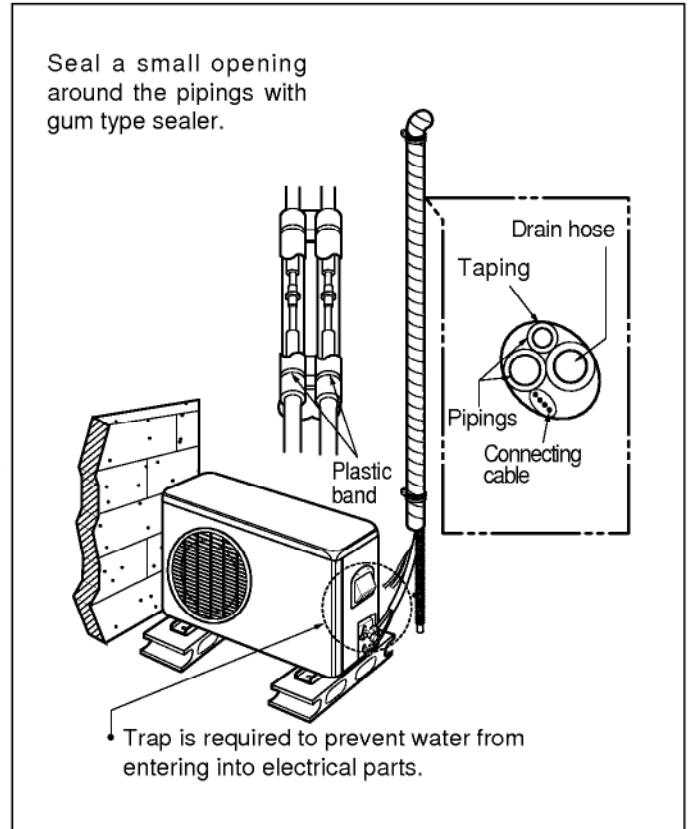

In case of the Outdoor unit being installed above position of the Indoor unit.

#### 2. Tape the Pipings and Connecting cable from down to up.

#### 3. Form the pipings gathered by taping along the exterior wall, make the Trap to be required to prevent water from entering into the room.

#### 4. Fix the pipings onto the wall by saddle or equivalent.

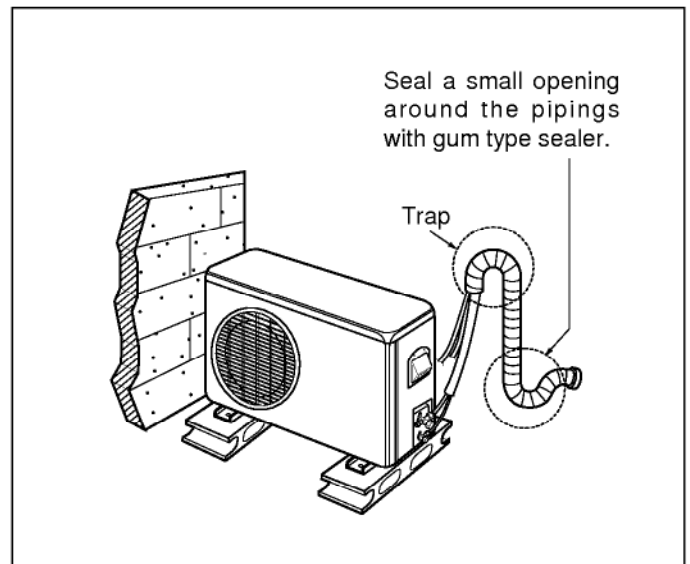

## (6) Air Purging

Air and moisture remaining in the refrigerant system have undesirable effects as indicated below.

- Pressure in the system rises.
- Operating current rises.
- Cooling(or heating) efficiency drops.
- Moisture in the refrigerant circuit may freeze and block capillary tubing.
- Water may lead to corrosion of parts in the refrigeration system.

Therefore, the indoor unit and tubing between the indoor and outdoor unit must be leak tested and evacuated to remove any noncondensables and moisture from the system.

### 1) Air Purging with a Vacuum Pump

#### § Preparation

Check that each tube(both liquid and gas side tubes) between the indoor and outdoor units has been properly connected and all wiring for the test run has been completed. Remove the valve caps from both the gas and the liquid side service valves on the outdoor unit. Note that both liquid and gas side service valves on the outdoor unit are kept closed at this stage.

#### § Leak test

1. Connect the manifold valve(with pressure gauges) and dry nitrogen gas cylinder to this service port with charge hoses.

**CAUTION:** Be sure to use a manifold valve for air purging. If it is not available, use a stop valve for this purpose. The "Hi" knob of the manifold valve must always be kept close.

2. Pressurize the system to no more than 150 P.S.I.G with dry nitrogen gas and close the cylinder valve when the gauge reading reached 150 P.S.I.G. Next, test for leaks with liquid soap.

**CAUTION:** To avoid nitrogen entering the refrigerant system in a liquid state, the top of the cylinder must be higher than its bottom when you pressurize the system. Usually, the cylinder is used in a vertical standing position.

3. Do a leak test of all joints of the tubing(both indoor and outdoor) and both gas and liquid side service valves. Bubbles indicate a leak. Be sure to wipe off the soap with a clean cloth.
4. After the system is found to be free of leaks, relieve the nitrogen pressure by loosening the charge hose connector at the nitrogen cylinder. When the system pressure is reduced to normal, disconnect the hose from the cylinder.

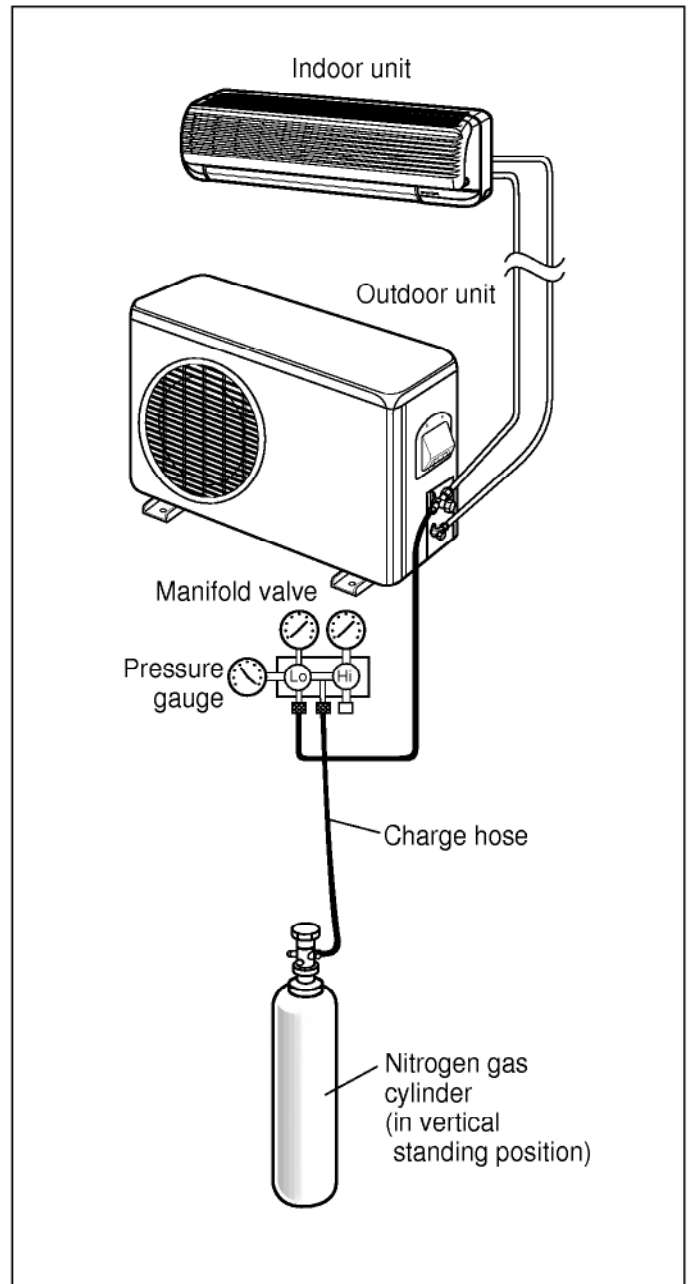

### § Evacuation

1. Connect the charge hose end described in the preceding steps to the vacuum pump to evacuate the tubing and indoor unit.

Confirm the "Lo" knob of the manifold valve is open. Then, run the vacuum pump.

The operation time for evacuation varied with the tubing length and capacity of the pump. The following table shows the amount of time for evacuation.

Allow the pump to operate until the system has been evacuated down to 300 microns. Allow the pump to continue running for an additional 15 minutes. Turn off the pump and leave the connections secured to the two service valves. After 5 minutes, if the system fails to hold 500 microns or less, check all connections for tight fit and repeat the evacuation procedure.

2. When the desired vacuum is reached, close the "Lo" knob of the manifold valve and stop the vacuum pump.

### § Finishing the job

1. With a service valve wrench, turn the valve stem of liquid side valve counter-clockwise to fully open the valve.
2. Turn the valve stem of gas side valve counter-clockwise to fully open the valve.
3. Loosen the charge hose connected to the gas side service port slightly to release the pressure, then remove the hose.
4. Replace the flare nut and its bonnet on the gas side service port and fasten the flare nut securely with an adjustable wrench. This process is very important to prevent gas leakage from the system.
5. Replace the valve caps at both gas and liquid side service valves and fasten them securely tight.

This complete air purging with a vacuum pump. The air conditioner is now ready to test run.

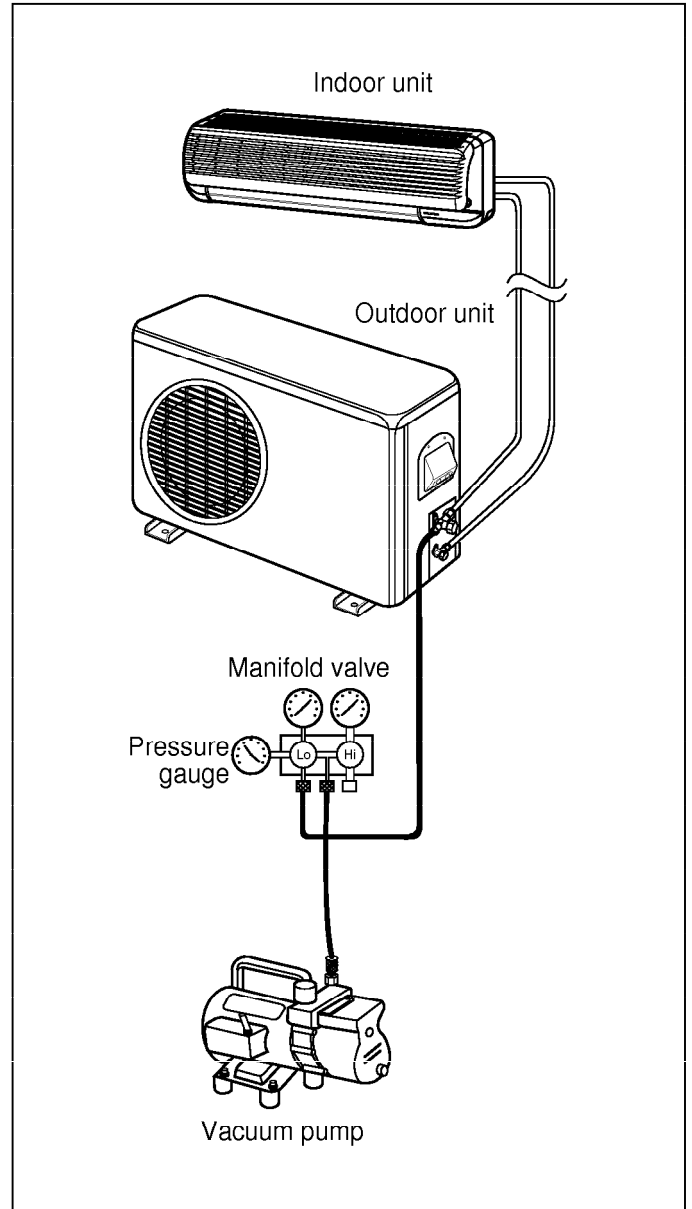



## (7) Test running

- (1) Check that all tubing and wiring have been properly connected.
- (2) Check that the gas and liquid side service valves are fully open.

### Prepare to Remote Control

- Insert two batteries provided.  
Remove the battery cover from the remote controller.
  - Slide the cover according to the arrow direction.  
Insert the two batteries.  
(Two "R03" or "AAA" dry-cell batteries or equivalent.)
  - Be sure that the (+) and (-) directions are correct.
  - Be sure that both batteries are new.  
Re-attach the cover.
  - Slide it back into position.
- (3) Turn on the power and run the unit.

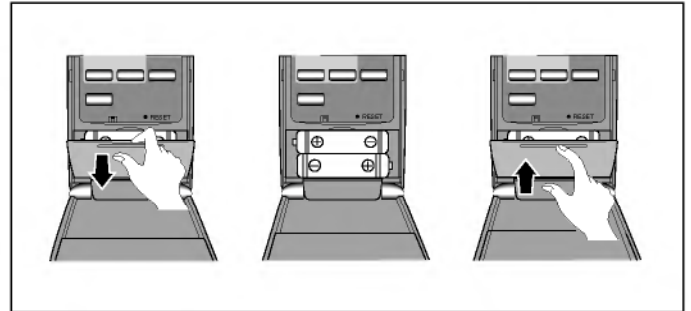

### Settlement of Outdoor Unit

- Anchor the outdoor unit with a bolt and nut ( $\phi 10\text{cm}$ ) tightly and horizontally on a concrete or rigid mount.
- When installing on the wall, roof or rooftop, anchor the mounting base securely with a nail or wire assuming the influence of wind and earthquake.
- In the case when the vibration of the unit is conveyed to the house, settle the unit with an anti-vibration rubber.

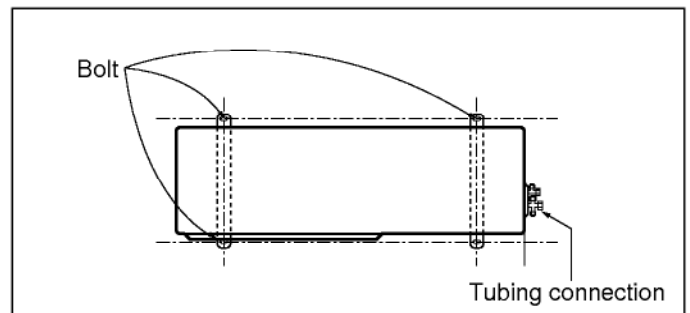

### Evaluation of the performance

Operate unit for 15~20 minutes, then check the system refrigerant charge:

- (1) Measure the pressure of the gas side service valve.
- (2) Measure the outside ambient air temperature.
- (3) For reference; the gas side pressure of optimum condition is as below;

Outside ambient TEMP.	The Pressure of the gas side service valve
35°C(95°F)	4~5kg/cm <sup>2</sup> (56.8~71.0 P.S.I.G)

**NOTE:** If the actual pressure are higher than shown, the system is most likely over-charged, and charge should be removed. If the actual pressure are lower than shown, the system is most likely undercharged, and charge should be added.

The air conditioner is now ready for actual operation.