

This Owner's Manual is provided and hosted by [Appliance Factory Parts](#).

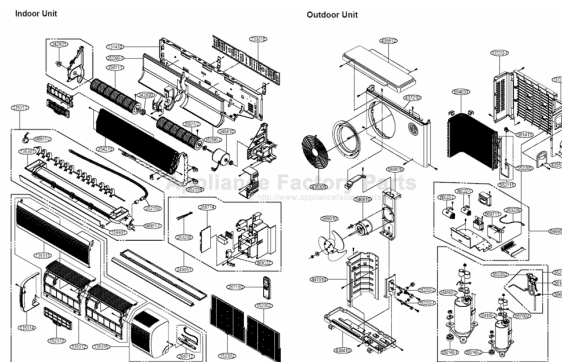

LG HMC030KD1 Owner's Manual

[Shop genuine replacement parts for LG HMC030KD1](#)



[Find Your LG Air Conditioner Parts - Select From 2328 Models](#)

----- Manual continues below -----



DELUXE HIGH WALL MINI SPLIT SERVICE MANUAL

**MODEL : HMC030KD1
HMH030KD1**

CAUTION

- BEFORE SERVICING THE UNIT, READ THE "SAFETY PRECAUTIONS" IN THIS MANUAL.
- ONLY FOR AUTHORIZED SERVICE PERSONNEL.

International Comfort Products

Contents

Functions	3
Product Specifications	5
Dimensions	7
Refrigeration Cycle Diagram	9
Pipe Length and the Elevation	10
Wiring Diagram	11
Operation Details	13
Display Function	20
Self-diagnosis Function	20
Installation	21
Operation	37
Disassembly of the parts (Indoor Unit)	39
3-way Valve	43
Cycle Troubleshooting Guide	48
Electronic Parts Troubleshooting Guide	49
Electronic Control Device	55
Schematic Diagram	58
Exploded View and Replacement Parts List	60

Functions

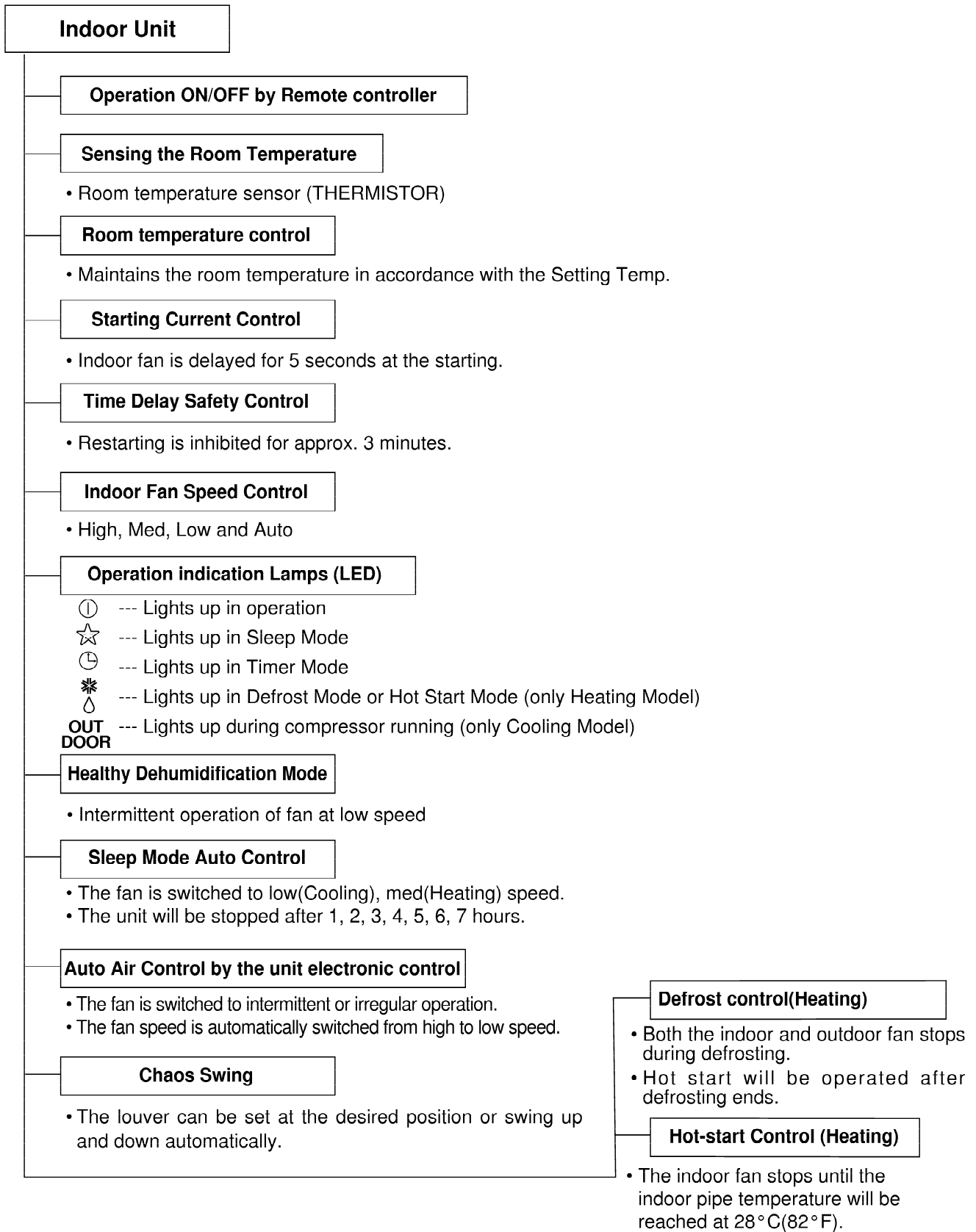

Product Specifications(Cooling Only)

Items		Unit	HMC030KD1
Power Supply		ø, V, Hz	230/208,60
Cooling Capacity		BTU/h	28,000/27,000
Input		W	3,600/3,450
Running Current		A	16.0/16.5
COMP. Locked Rotor AMP.		A	68
E.E.R		BTU/hW	7.81/7.79
Air Circulation		m ³ /min(cfm)	21(740)
Moisture Removal		l/h(pts/hr)	3.7(7.8)
Noise Level (Sound Pressure, 1m)	Indoor, High	dB(A)	49
	Med	dB(A)	46
	Low	dB(A)	43
	Outdoor, Max	dB(A)	63
Features	Temperature Control		Thermistor
	Air Deflection		4-way
	Steps, Fan/Cool		3/3
	Airflow Direction Control(up&down)		Auto
	Airflow Direction Control(left&right)		Manual
	Remocon Type		Wireless LCD
	Setting Temperature Range, Cooling Mode		64-86°F
	Temperature Increment		2°F
	Auto Operation(electronic control)		Yes
	Self Diagnosis		Yes
	Timer		24hr, On/Of
	Sleep Operation		Yes
	Healthy Dehumidification Mode		Yes
Restart Delay		minutes	3
Refrigerant(R-22) Charge		g(oz)	2550(89.9)
Power cord		AWG #: P*mm ²	12:3*2.5
Fuse or breaker Capacity		A	30A
Connecting Cable		AWG #: P*mm ²	16:4*0.75
Connecting Tube (ø. Socket Flare)	Liquid Side	mm(in)	6.35(1/4)
	Gas Side	mm(in)	12.7(1/2)
	Length, std	m(ft)	7.62(25)
Additional Drain Hose(Outer Dia.)		mm(in)	15.5(5/8)
Dimensions (WxHxD)	Indoor	mm	1259*349*205
		in	49.6*13.7*8.1
	Outdoor	mm	870*800*320
		in	34.3*31.5*12.6
Net Weight	Indoor	kg(lbs)	20
	Outdoor	kg(lbs)	71

* Design and Specifications subject to change without prior notice for product improvement.

Product Specifications(Cooling & Heating)

Items		Unit	HMH030KD1
Power Supply		ø, V, Hz	1,230/208,60
Cooling Capacity		BTU/h	28,000/27,000
Heating Capacity		BTU/h	29,000/28,000
Input	Cooling	W	3,600/3,450
	Heating	W	3,750/3,550
Running Current	Cooling	A	16.0/16.5
	Heating	A	16.5/17.0
COMP. Locked	Cooling	A	68
Rotor AMP.	Heating	A	68
E.E.R		BTU/hW	7.78/7.82
C.O.P			2.26/2.30
Air Circulation		m ³ /min(cfm)	21(740)
Moisture Removal		l/h(pts/hr)	3.7(7.8)
Noise Level (Sound Pressure, 1m)	Indoor, High	dB(A)	49
	Med	dB(A)	46
	Low	dB(A)	43
	Outdoor, Max	dB(A)	63
Features	Temperature Control		Thermistor
	Air Deflection		4-way
	Steps, Fan/Cool/Heat		3/3/3
	Airflow Direction Control(up&down)		Auto
	Airflow Direction Control(left&right)		Manual
	Remocon Type		Wireless LCD
	Setting Temperature Range, Cooling Mode		64~86°F
	Heating Mode		60~86°F
	Temperature Increment		2°F
	Auto Operation(electronic control)		Yes
	Self Diagnosis		Yes
	Timer		24hr, On/Off
	Sleep Operation		Yes
	Healthy Dehumidification Mode		Yes
	Restart Delay	minutes	3
Defrost Control		Yes	
Hot Start		Yes	
Refrigerant(R-22) Charge		g(oz)	2550(89.9)
Power cord		AWG #: P*mm ²	12:3*2.5
Fuse or breaker Capacity		A	30A
Connecting Cable		AWG #: P*mm ²	18:4*0.75
Connecting Tube (ø. Socket Flare)	Liquid Side	mm(in)	9.52(3/8)
	Gas Side	mm(in)	15.88(5/8)
	Length, std	m(ft)	7.62(25)
Additional Drain Hose(Outer Dia.)		mm(in)	15.5(5/8)
Dimensions (WxHxD)	Indoor	mm	1259*349*205
		in	49.6*13.7*8.1
Outdoor	mm	770*540*245	870*800*320
		in	34.3*31.5*12.6
Net Weight	Indoor	kg(lbs)	20
	Outdoor	kg(lbs)	33(72.8)

* Design and Specifications subject to change without prior notice for product improvement.

Dimensions

(1) Indoor Unit

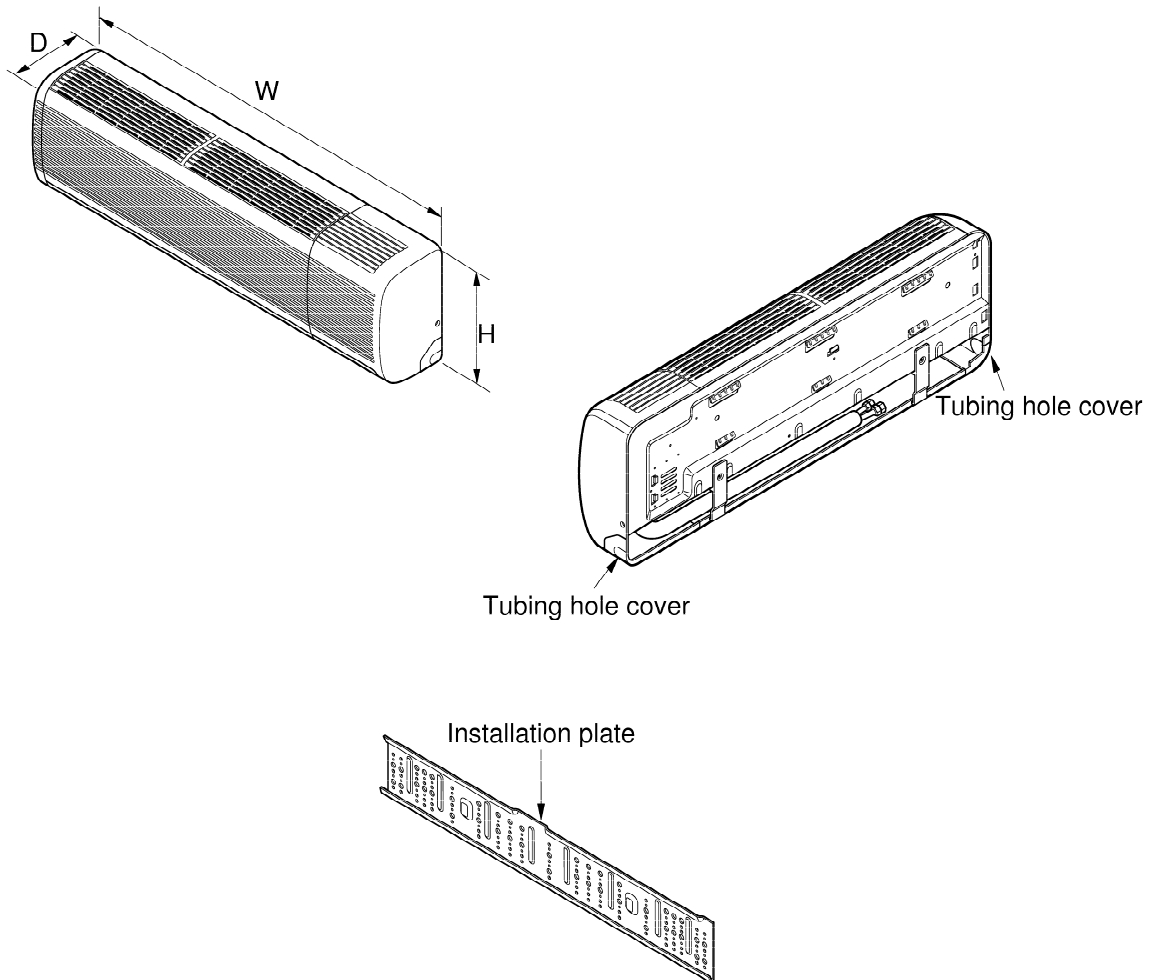

Dimension		Model	30K SERIES
		W	mm(inch)
H	mm(inch)	349(13.7)	
D	mm(inch)	205(8.1)	

(2) Outdoor Unit

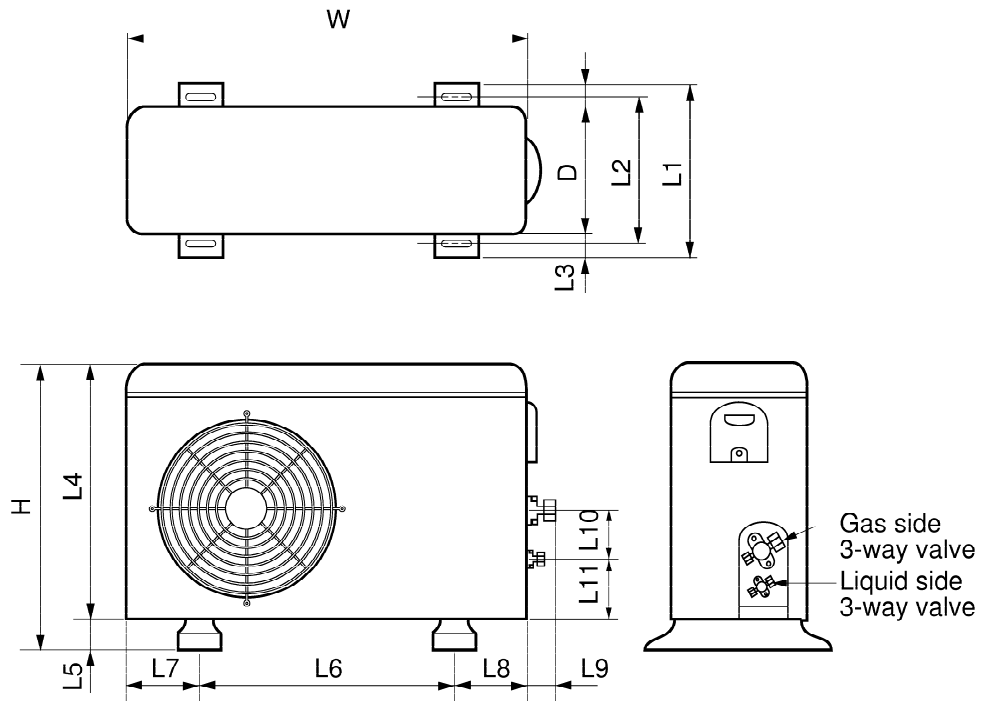

DIM \ MODEL		30K SERIES
W	mm(in ch)	870(34.3)
H	mm(in ch)	800(31.5)
D	mm(in ch)	320(12.6)
L1	mm(in ch)	370(14.6)
L2	mm(in ch)	340(13.4)
L3	mm(in ch)	25(1.0)
L4	mm(in ch)	775(30.5)
L5	mm(in ch)	25(1.0)
L6	mm(in ch)	546(21.5)
L7	mm(in ch)	162(6.4)
L8	mm(in ch)	162(6.4)
L9	mm(in ch)	54(2.1)
L10	mm(in ch)	74.5(2.9)
L11	mm(in ch)	79(3.1)

Refrigeration Cycle Diagram

(1) Cooling Only Models

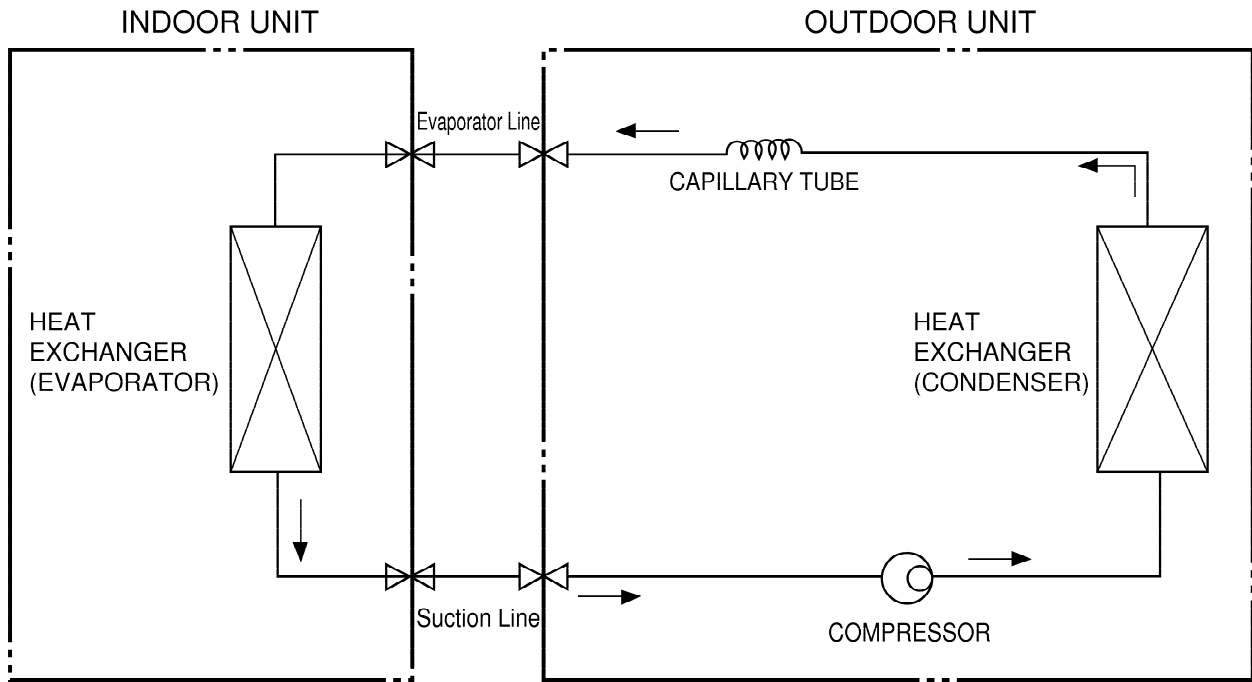

(2) Cooling & Heating Models

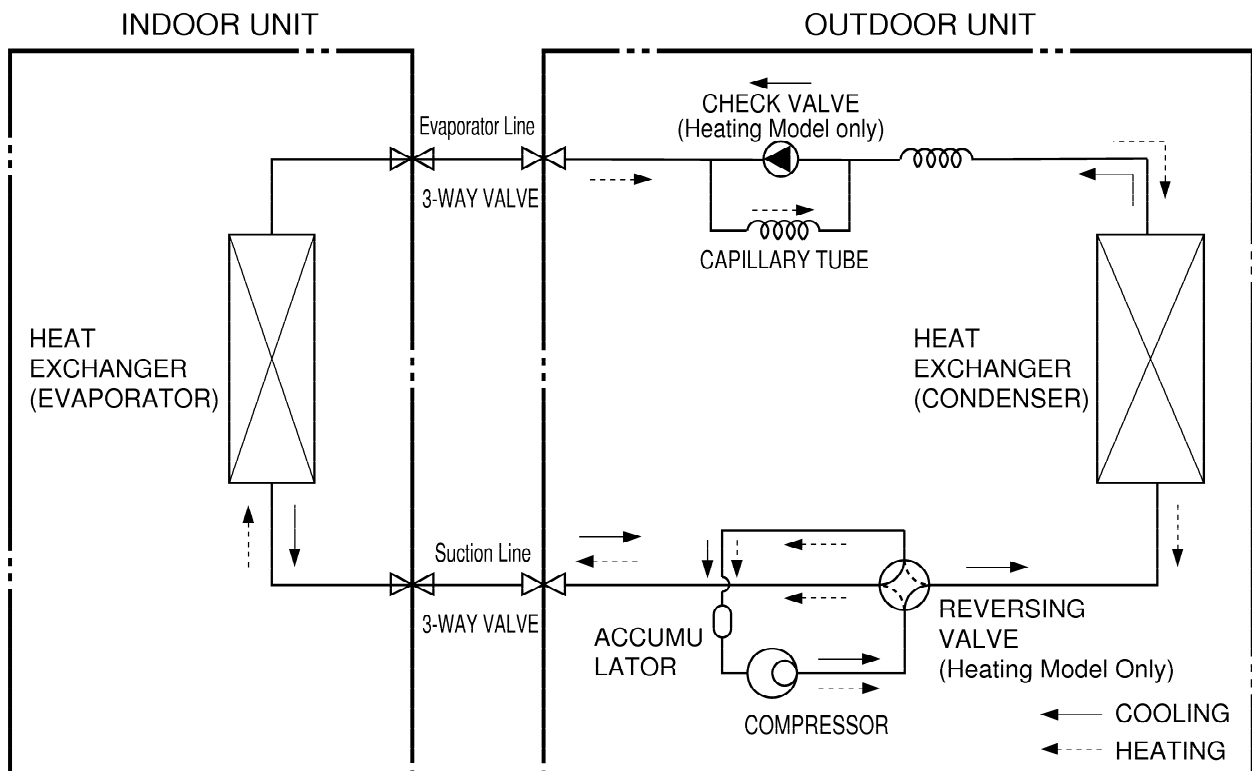

Pipe length and the elevation

Capacity (Btu/h)	Pipe Size		Standard Length m(ft)	Max. Elevation ⓑ m(ft)	Max. Length ⓐ m(ft)	Additional Refrigerant g/m(oz/ft)
	GAS	LIQUID				
30k (50Hz, 60Hz)	5/8"	3/8"	7.5(25)	15(50)	30(100)	30(0.32)

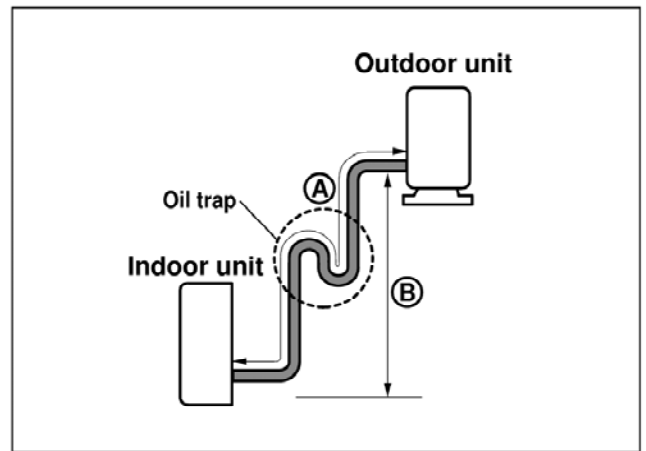
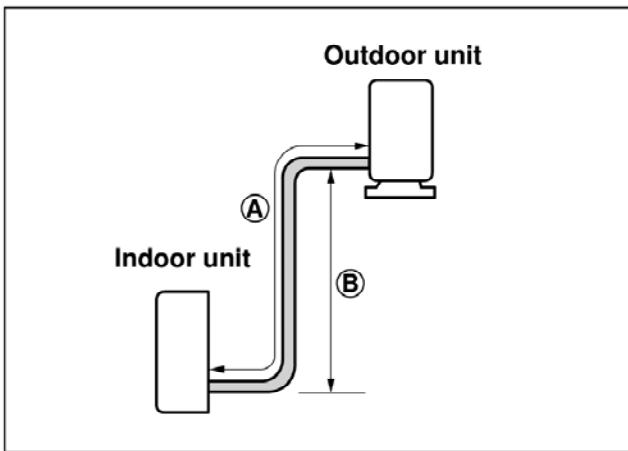

In case more than 5m (16.4ft)

CAUTION

- * Capacity is based on standard length and maximum allowance length is the basis of reliability.
- * Oil trap should be installed per 5~7 meters(16.4~23.0ft).

Wiring Diagram

(1) Indoor Unit (Cooling Only Models, & Heating Models)

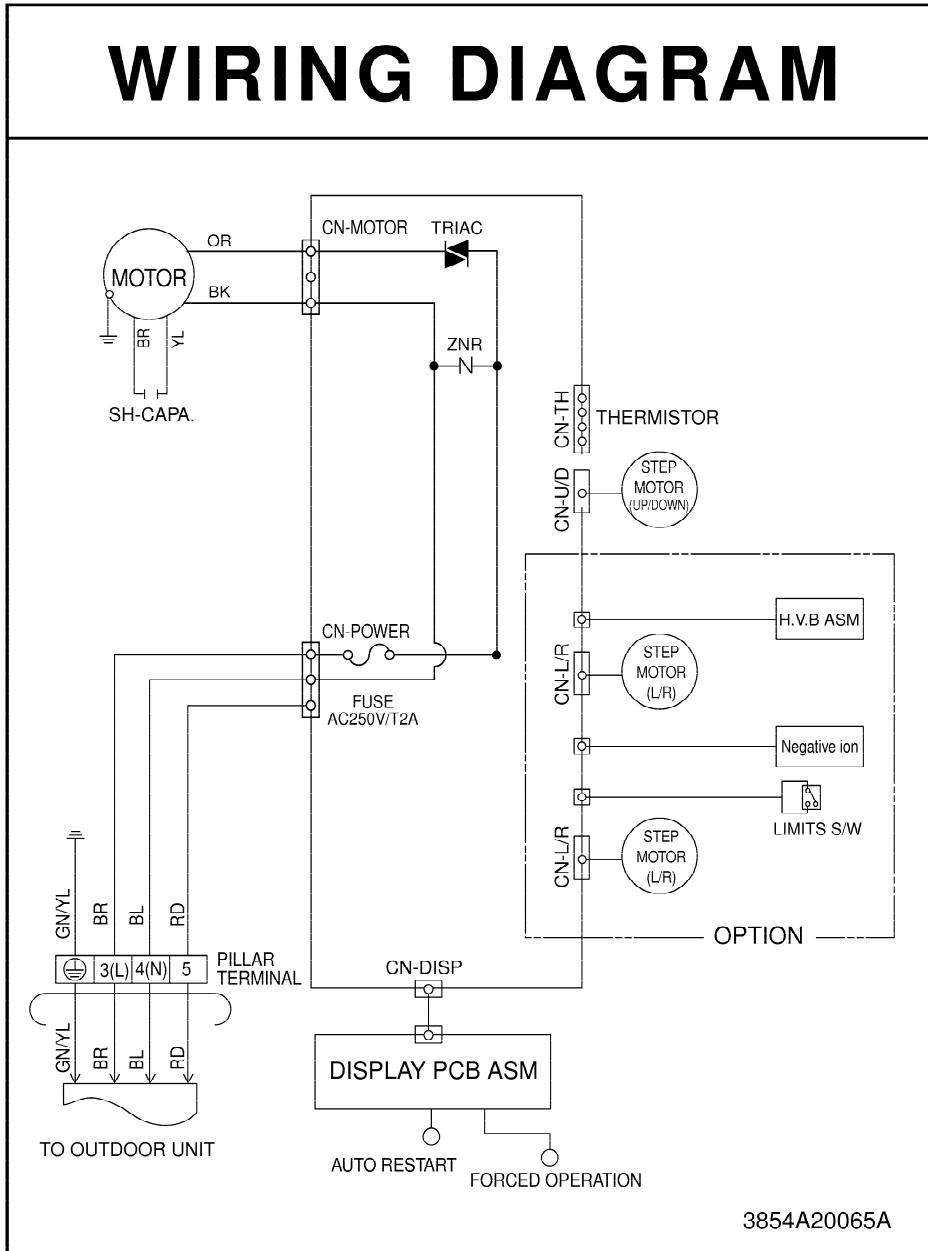

(2) Outdoor Unit
 • Cooling Only Models

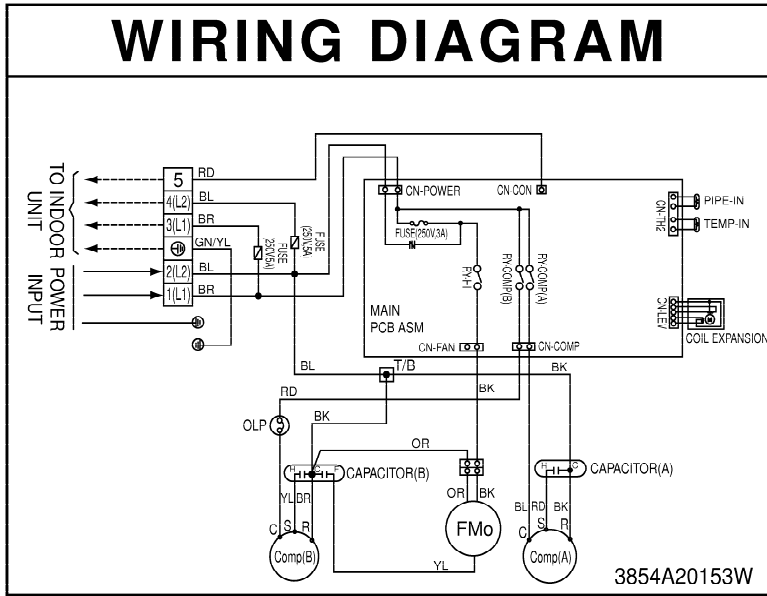

• Heating Models

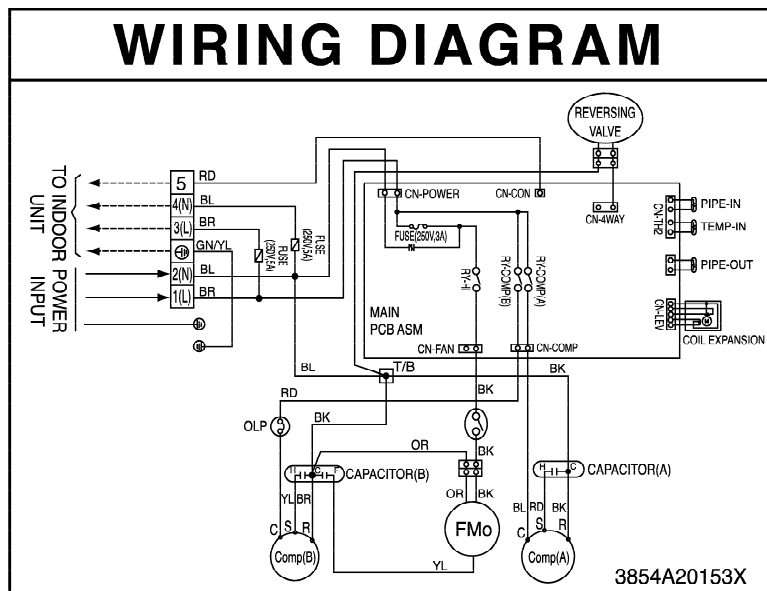

Operation Details

(1) The function of main control

1. Time delay Safety Control

- 3min.; The compressor operation is delayed for 3 minutes to balance the pressure of cycle.
(Protection of compressor)
- 5sec.; The indoor fan is delayed for 5 seconds, when operating initially, to prevent noises occurred by the vertical louver and wind.
- 2min.; The reversing valve is delayed for 2 minutes to prevent the refrigerant-gas for abnormal noise when the heating operation is OFF or switched to the other operation mode while compressor is off.
While compressor is running, it takes 3~5 seconds to switch.

2. Chaos Swing Mode

- By the Chaos Swing key input, the upper/lower vane automatically operates with the Chaos Swing or they are fixed to the desired direction.
- While in Chaos Swing mode, the angles of cooling and heating cycle operations are different.

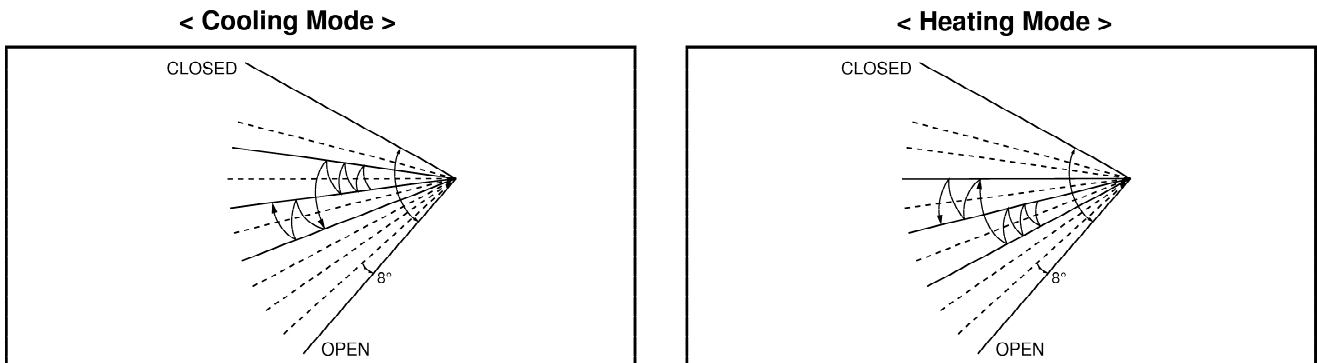

3. Cooling Operation Mode

- When selecting the Cooling(※) Mode Operation, the unit will operate according to the setting by the remote control and the operation diagram is shown below.

INTAKE AIR TEMP.	[Graph showing intake air temperature fluctuating between setting +1°F and -1°F]				
SETTING TEMP. +1°F (Compressor ON)	[Graph showing compressor ON when temperature is above +1°F]				
SETTING TEMP. -1°F (Compressor OFF)	[Graph showing compressor OFF when temperature is below -1°F]				
		More than 3 minutes		More than 3 minutes	
INDOOR FAN SPEED	Setting fan speed	Low	Setting fan speed	Low	Setting fan speed
COMPRESSOR	ON	OFF	ON	OFF	ON

■ Protection of the indoor heat exchanger from frosting

- Compressor and outdoor fan stop when indoor pipe temperature is below 0°C(32°F) and restart at the pipe temperature is above 7°C(45°F).

. Auto Operation (Electronic control mode)

• The operation procedure is shown below. (Cooling & Heating Model)

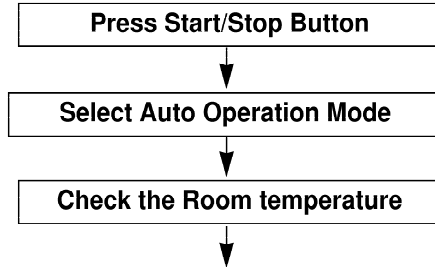

Operation mode Indoor fan speed Setting temperature				are decided automatically by the unit electronic control.
Intake-air temperature	below 70°F	Over 70°F ~ below 76°F	Over 76°F	
Operation Mode	Heating	Soft Dry	Cooling	

* If initial mode is decided, that mode is continued without the room temperature changing.

■ Auto Operation for Cooling

Operation Condition	Intake-air Temperature	Setting Temperature	Fan Speed	Air Direction Control
When Auto Operation initial start	Over 78°F	77°F	Controlled by the electronic control	In this mode, when pressing the vertical air direction control button, vertical louver swings up and down automatically.
	Over 76°F~below 78°F	Intake air -1°C		
	Over 72°F~below 76°F	Intake air -0.5°C		
	Over 68°F~below 72°F	Intake air temperature		
	below 64°F	64°F		
When pressing room temperature setting button during Auto Operation	Over 64°F~below 86°F	Electronic control		
	below 64°F	64°F		
	over 86°F	86°F		

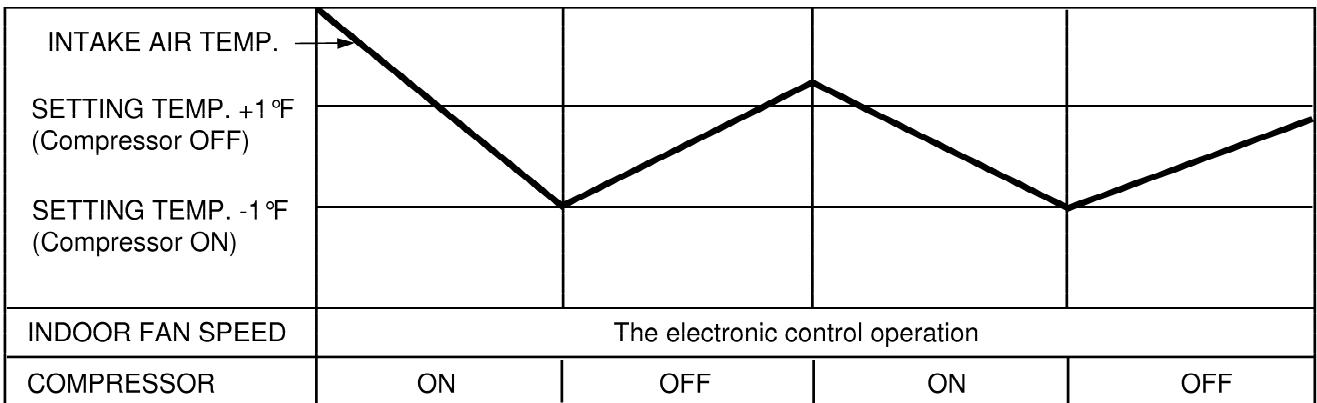

■ **Auto Operation for Dehumidification(only Heating Model)**

- The Setting temperature will be same that of the auto operation for cooling.
 - Compressor ON temperature; Setting temperature +2°F
 - Compressor OFF temperature; Setting temperature -1°F

Intake-air temp.	below 68°F	Over 68°F~below 70°F	over 86°F
Setting temp.	68°F	Intake air temperature +1°F	86°F

■ **Auto Operation for Heating(only Heating Model)**

- Compressor ON temperature; Setting temperature
- Compressor OFF temperature; Setting temperature +6°F

■ **Vertical louver auto operation** : During Auto Operation, pressing the chaos swing button makes the horizontal louvers swing up and down automatically.
If you want to stop auto-swing, press chaos swing button again.

5. Healthy Dehumidification

- When the dehumidification operation input by the remote control is received, the intake air temperature is detected and the setting temp is automatically set according to the intake air temperature.
 - 26°C ≤ Intake Air Temp ⇨ 25°C
 - 24°C ≤ Intake Intake Air Temp < 26°C ⇨ Intake Air Temp - 1 °C
 - 18°C ≤ Intake Intake Air Temp < 24°C ⇨ Intake Air Temp - 0.5°C
 - Intake Air Temp < 18°C ⇨ 18°C
- While in compressor off, the indoor fan repeats low airflow speed and pause.
- While the intake air temp is between compressor on temp. and compressor off temp., 10-min dehumidification operation and 4-min compressor off repeat.
 - Compressor ON Temp. ⇨ Setting Temp + 0.5°C
 - Compressor OFF Temp. ⇨ Setting Temp - 0.5°C
- In 10-min dehumidification operation, the indoor fan operates with the low airflow speed.

6. Heating Operation Mode(only Heating Model)

The unit will operate according to the setting conditions by the remote controller.
The operation diagram is shown below.

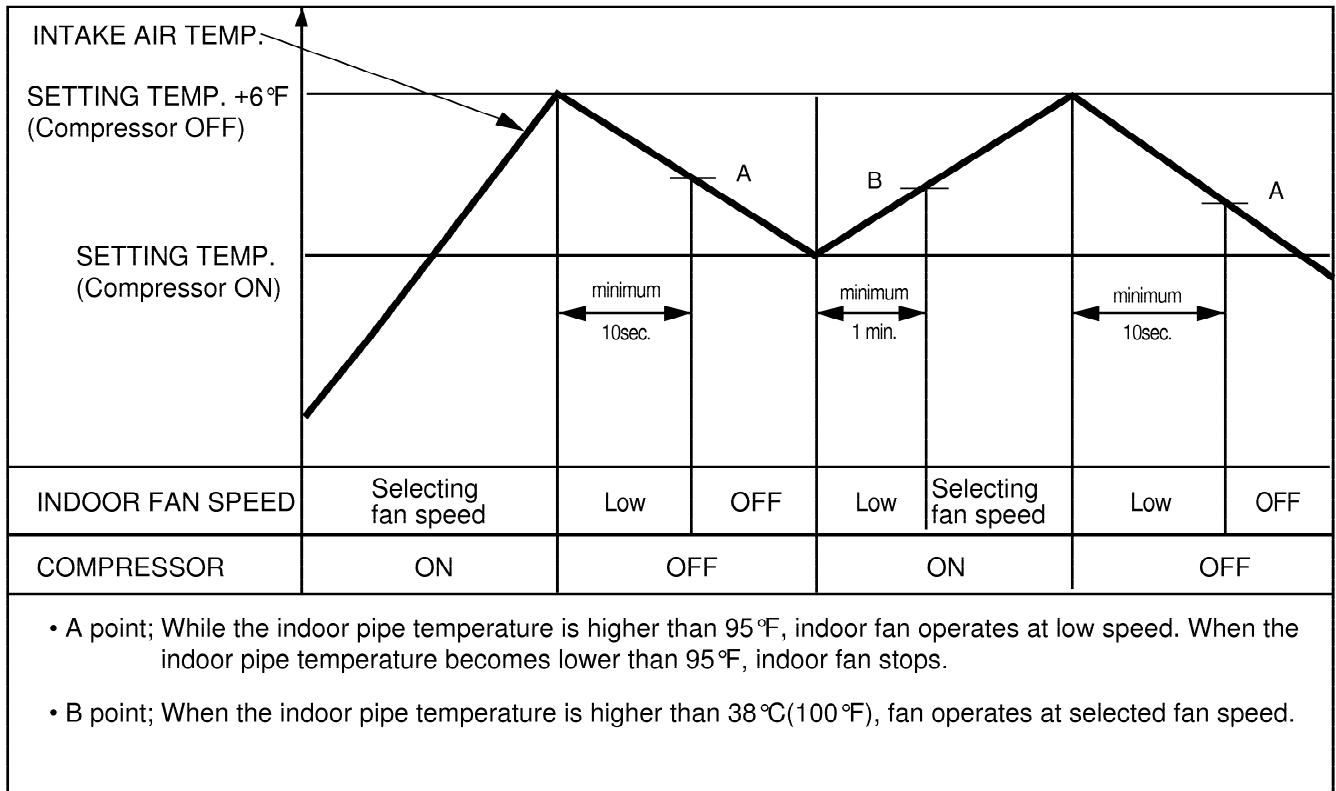

■ Hot-Start Control

- The indoor fan stops until the indoor pipe temperature will be reached at 82°F.
- During heating operation, if indoor pipe temperature falls below 78°F fan stops.
- The operation diagram is shown below.

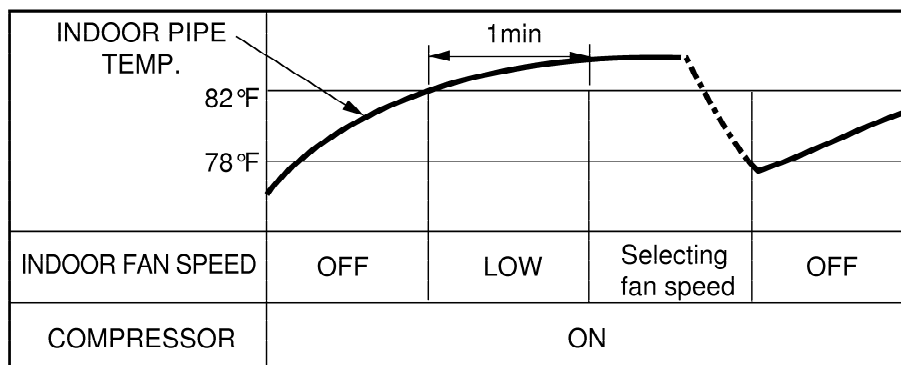

7. Cooling or Heating Mode with Sleep Mode Auto Control

- When selecting the Cooling() or the Heating(✕) combined with the Sleep Mode Auto Control(☆), the operation diagram is as following.

■ Cooling Mode with the Sleep Mode

- The setting temperature will be automatically raised by 2°F 30 minutes later and by 4°F 1 hour later.
- The operation will be stopped after 1, 2, 3, 4, 5, 6, 7 hours.

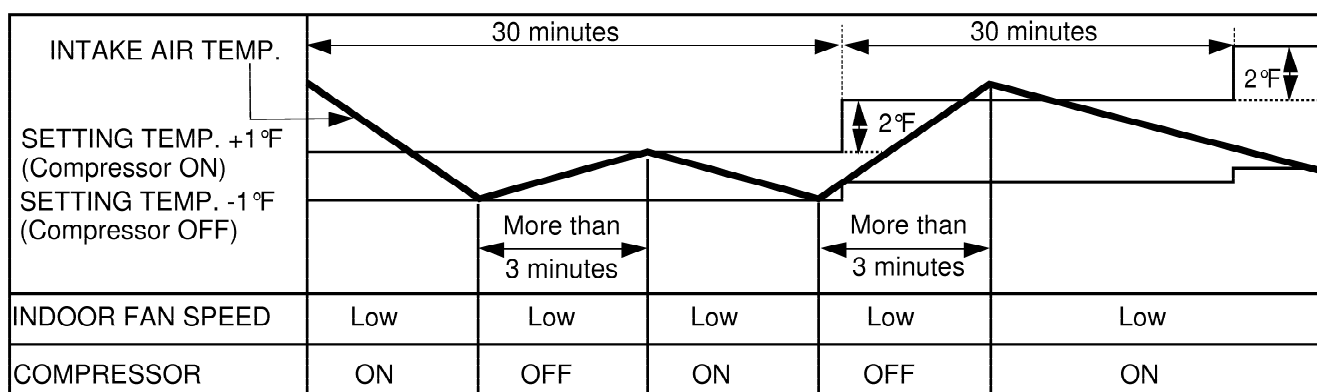

■ Heating Mode with the Sleep Mode(only Heating Model)

- The operation will be stopped after 1, 2, 3, 4, 5, 6, 7 hours.

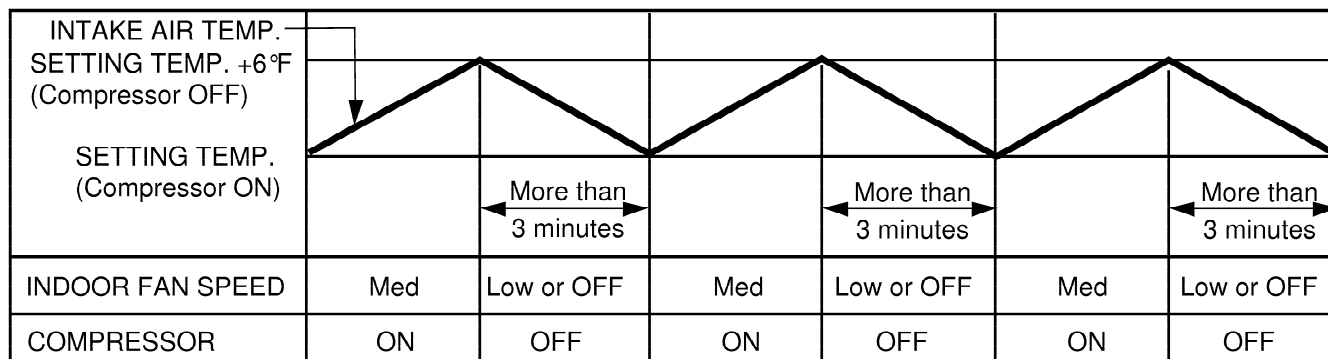

8. Forced Operation

To operate the appliance by force in case that the remote controller is lost, the forced operation button is on the main unit of the appliance to operate the appliance in the standard conditions.

- Press the forced operation button, the forced operation is carried out.
- Press the forced operation button once again to stop operation.

In case the power comes on again after power failure on the Forced Operation position, the operating conditions are automatically set as follows:

During Forced Operation, the initial mode continues.

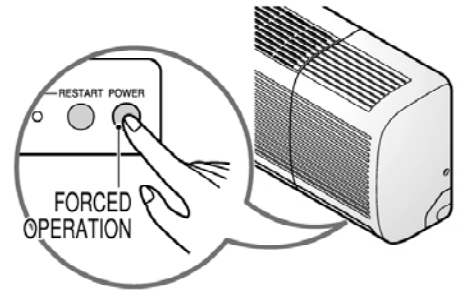

	Cooling Model	Heat pump Model		
		Room Temp. $\geq 24^{\circ}\text{C}(76^{\circ}\text{F})$	$21^{\circ}\text{C}(70^{\circ}\text{F}) \leq \text{Room Temp.} < 24^{\circ}\text{C}(76^{\circ}\text{F})$	Room Temp. $< 21^{\circ}\text{C}(70^{\circ}\text{F})$
Operating mode	Cooling	Cooling	Healthy Dehumidification	Heating
Indoor FAN Speed	High	High	Healthy Dehumidification Rule	High
Setting Temperature	$22^{\circ}\text{C}(72^{\circ}\text{F})$	$22^{\circ}\text{C}(72^{\circ}\text{F})$	$23^{\circ}\text{C}(74^{\circ}\text{F})$	$24^{\circ}\text{C}(76^{\circ}\text{F})$

9. AUTO RESTART

In case the power comes on again after a power failure, Auto Restarting Operation is the function to operate procedures automatically to the previous operating conditions.

If you want to use this operation. The autorestart button is on the main unit of the appliance in the standard condition.

- press the auto restart button, to make this function active.
- If you do not want to use this operation, free the auto restart button once again.

If you do not want to use this operation, move the Slide Switch to the Remote Control position.

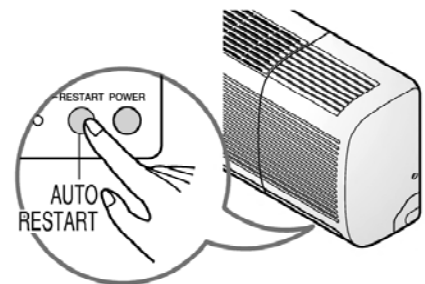

Display Function

Signal Receptor

Receives the signals from the remote control. (Signal receiving sound: two short beeps or one long beep.)

Operation Indication Lamps

- ① **On/Off** : Lights up during the system operation.
- ⌚ **Timer or Sleep Mode** : Lights up during Timer operation or Sleep mode.
- * ⓪ **Defrost Mode** : Lights up during Defrost Mode or Hot Start operation. (Heat pump model only)
- ^{OUT}_{DOOR} **Outdoor unit operation** : Lights up during outdoor unit operation. (Cooling model only)
- ⎓ **Auto Restart Mode** : Lights up during if Restart Button is pressed.
- ^{RESTART} ⓪ **Auto Restart Button** : In failure of electric power, if the button is pressed the unit runs as previous setting operation when power returns.
- ^{POWER} ⓪ **Forced Operation Button** : Operation starts, when this button is pressed and stops when you press the button again.

Self-diagnosis Function

Error Code	Error LED (Indoor body operation LED)	Error contents	SVC check point
1	<p>(once)</p> <p>3sec</p>	<ul style="list-style-type: none"> • Indoor room temperature thermistor open/short • Indoor pipe temperature thermistor open/short. 	<ul style="list-style-type: none"> • Indoor TH assy check
2	<p>(twice)</p> <p>3sec</p>	<ul style="list-style-type: none"> • Outdoor pipe temperature thermistor open/short. 	<ul style="list-style-type: none"> • Outdoor TH assy check
5	<p>(5times)</p> <p>3sec</p>	<ul style="list-style-type: none"> • Poor communication. 	<ul style="list-style-type: none"> • Communication line/circuit check

Installation

Read completely, then follow step by step.

1. Installation of Indoor, Outdoor unit

Installation Parts Provided

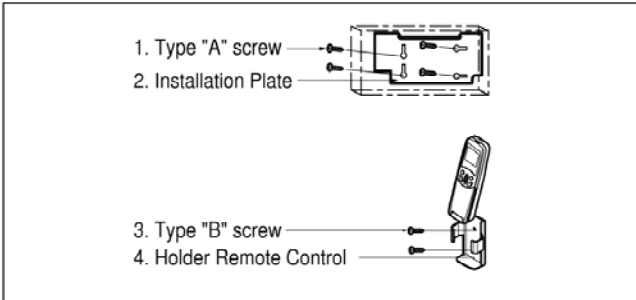

1) Select the best location

1. Indoor unit

- Do not have any heat or steam near the unit.
- Select a place where there are no obstacles in front of the unit.
- Make sure that condensation drainage can be conveniently routed away.
- Do not install near a doorway.
- Ensure that the space around the left and right of the unit is more than 30cm(12"). The unit should be installed as high on the wall as possible, allowing a minimum of 12cm(4.8") from ceiling.
- Use a stud finder to locate studs to prevent unnecessary damage to the wall.

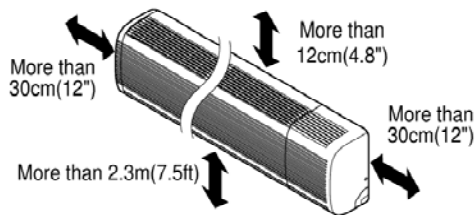

CAUTION

Install the indoor unit on the wall where the height from the floors more than 2.3meters(7.5ft). A minimum pipe run of 7.5meters(25ft) is required to minimise vibration & excessive noise.

2. Outdoor unit

- If an awning is built over the unit to prevent direct sunlight or rain exposure, make sure that heat radiation from the condenser is not restricted.
- Ensure that the space around the back and sides is more than 10cm(4"). The front of the unit should have more than 70cm(28") of space.
- Do not place animals and plants in the path of the warm air.
- Take the air conditioner weight into account and select a place where noise and vibration are minimum.
- Select a place so that the warm air and noise from the air conditioner do not disturb neighbors.

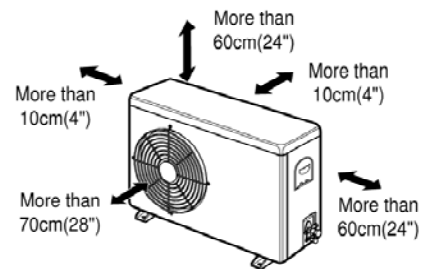

■ Rooftop Installations:

If the outdoor unit is installed on a roof structure, be sure to level the unit. Ensure the roof structure and anchoring method are adequate for the unit location. Consult local codes regarding rooftop mounting. If the outdoor unit is installed on roof structures or walls, this may result in excessive noise and vibration, and maybe also classed as non serviceable installation.

2) Piping length and elevation

Capacity (Btu/h)	Pipe Size		Standard Length m(ft)	Max. Elevation (B) m(ft)	Max. length (A) m(ft)	Additional Refrigerant g/m(oz/ft)
	GAS	LIQUID				
30k	5/8"	3/8"	7.5(25)	15(50)	30(100)	30(1.102)

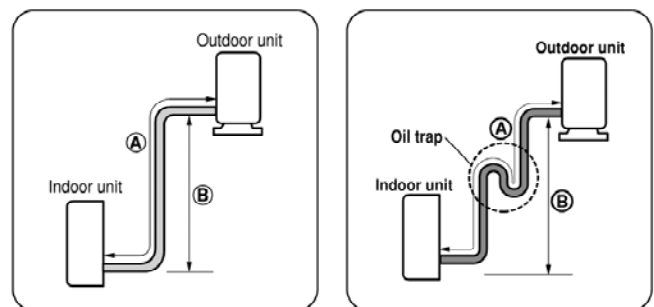

In case more than 5m(16.4ft)

CAUTION

- Capacity is based on standard length and maximum allowance length is on the basis of reliability.
- Oil trap should be installed In case more than 5~7meters (16.4~23.0ft).

3) How to fix installation plate

The wall you select should be strong and solid enough to prevent vibration

1. Mount the installation plate on the wall with four type A screws. If mounting the unit on a concrete wall, use anchor bolts.

- Mount the installation plate horizontally by aligning the centerline using a level.

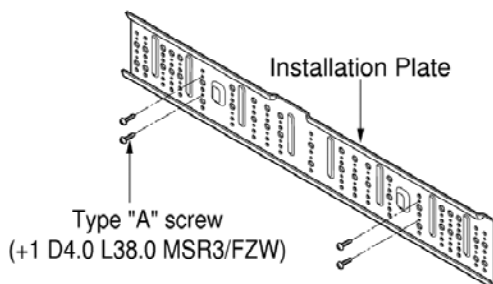

2. Measure the wall and mark the centerline. It is also important to use caution concerning the location of the installation plate—routing of the wiring to power outlets is through the walls typically. Drilling the hole through the wall for piping connections must be done safely.

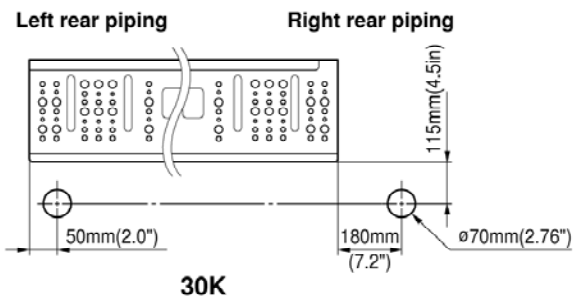

4) Drill a hole in the wall

- Drill the piping hole with a ø70mm (0.76") hole core drill. Drill the piping hole at either the right or the left with the hole slightly slanted to the outdoor side.

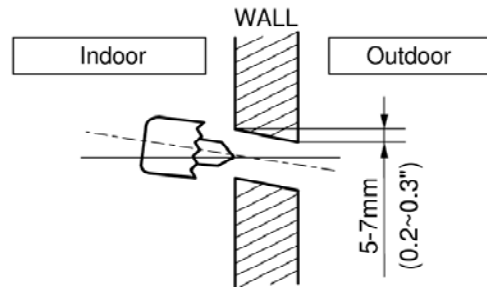

2. Flaring Work and Connection of Piping

1) Flaring work

Main cause for gas leakage is due to defect in flaring work. Carry out correct flaring work in the following procedure.

1. Cut the pipes and the cable.

- Use the piping kit accessory or the pipes purchased locally.
- Measure the distance between the indoor and the outdoor unit.
- Cut the pipes a little longer than measured distance.
- Cut the cable 1.5m(59.1") longer than the pipe length.

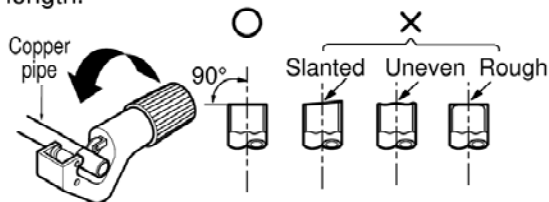

2. Burrs removal

- Completely remove all burrs from the cut cross section of pipe/tube.
- Put the end of the copper tube/pipe in a downward direction as you remove burrs in order to avoid dropping burrs into the tubing.

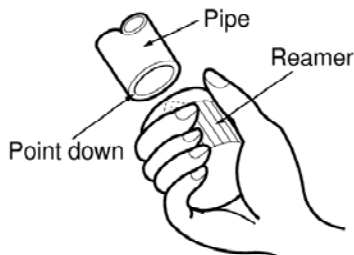

3. Putting nut on

- Remove flare nuts attached to indoor and outdoor unit, then put them on pipe/tube having completed burr removal. (not possible to put them on after flaring work)

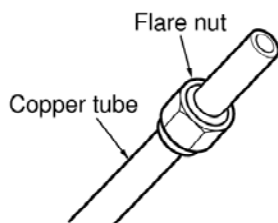

4. Flaring work

- Carry out flaring work using flaring tool as shown below.

Outside diameter		A
mm	inch	mm
ø6.35	1/4	0 ~ 0.5
ø9.52	3/8	0 ~ 0.5
ø12.7	1/2	0 ~ 0.5
ø15.88	5/8	0 ~ 1.0

Firmly hold copper pipe in a die in the dimension shown in the table above.

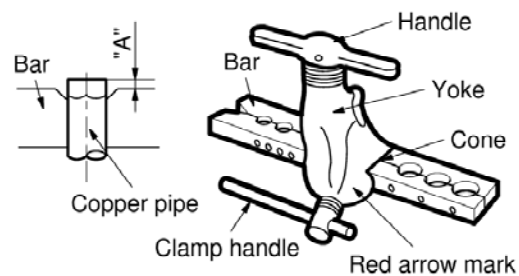

5. Check

- Compare the flared work with figure below.
- If flare is noted to be defective, cut off the flared section and do flaring work again.

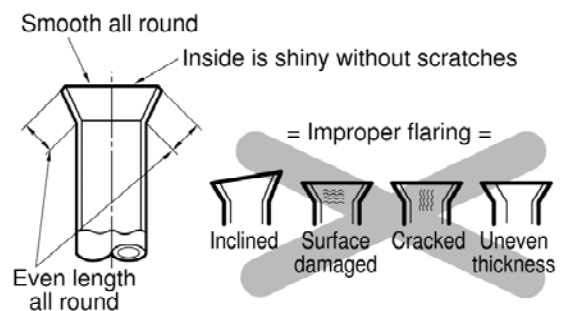

2) Connection of piping-Indoor

1. Remove the 2 screws of right side panel.

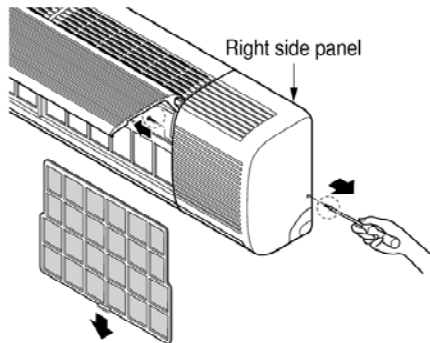

2. Remove the front right side panel by the arrow.

- The connector can be disconnected by pulling it while pressing the connector's hook.
- Remove the 1 screw for fixing lower panel.

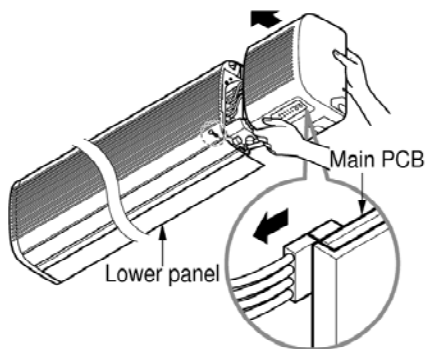

3. Remove the lower panel by the arrow.

- Take care not to scratch the wall and mat to drop.

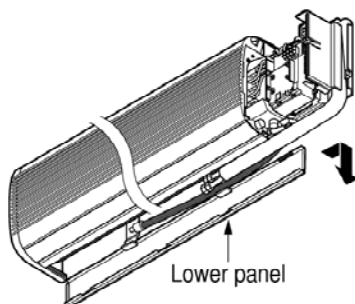

CAUTION

When install, make sure that the remaining parts must be removed clearly so as not to damage the piping and drain hose, especially power cord and connecting cable.

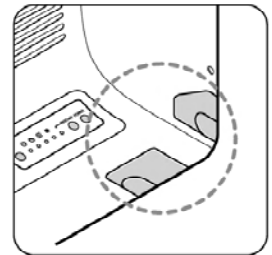

For left rear piping

1. Route the indoor tubing and the drain hose in the direction of rear left.

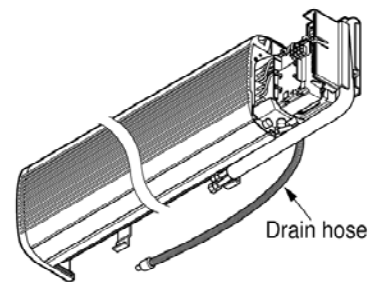

2. Insert the connecting cable into the indoor unit from the outdoor unit through the piping hole.

- Do not connect the cable to the indoor unit.
- Make a small loop with the cable for easy connection later.

3. Tape the tubing, drain hose and the connecting cable. Be sure that the drain hose is located at the lowest side of the bundle. Locating at the upper side can cause drain pan to overflow inside the unit.

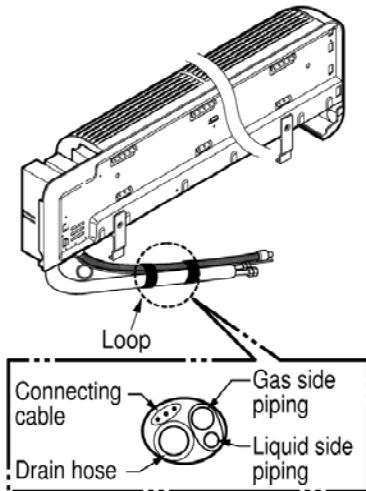

NOTE: If the drain hose is routed inside the room, insulate the hose with an insulation material* so that dripping from "sweating"(condensation) will not damage furniture or floors.
*Foamed polyethylene or equivalent is recommended.

4. Indoor unit installation

■ Hook the indoor unit onto the upper portion of the installation plate.(Engage the three hooks of the rear top and rear lower of the indoor unit with the upper edge and lower edge of the installation plate.) Ensure that the hooks are properly seated on the installation plate by moving it left and right.

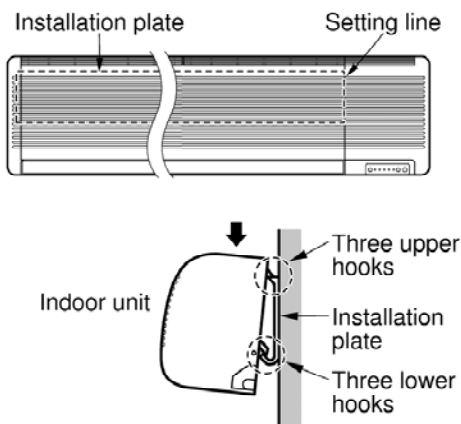

5. Connecting the pipings to the indoor unit and drain hose to drain pipe.

■ Align the center of the pipings and sufficiently tighten the flare nut by hand.

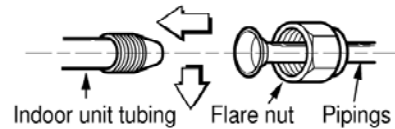

■ Tighten the flare nut with a wrench.

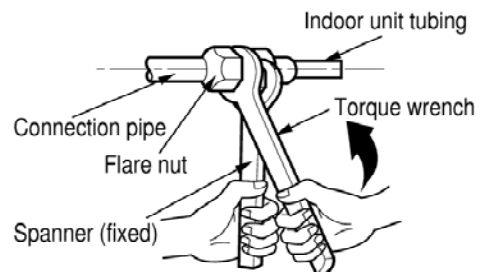

Capacity (Btu/h)	Pipe Size[Torque]	
	Suction	Evaporator
30K	5/8"[6.6kg.m]	3/8"[4.2kg.m]

■ When extending the drain hose at the indoor unit, install the drain pipe.

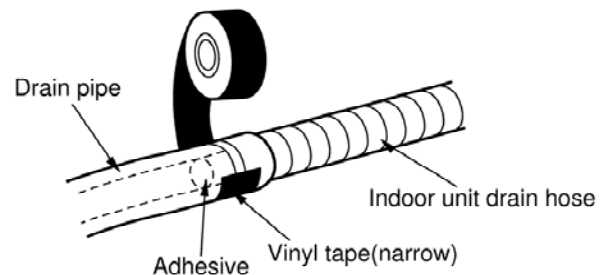

6. Wrap the insulation material around the connecting portion.

- Overlap the connection pipe insulation material and the indoor unit pipe insulation material. Bind them together with vinyl tape so that there is no gap.

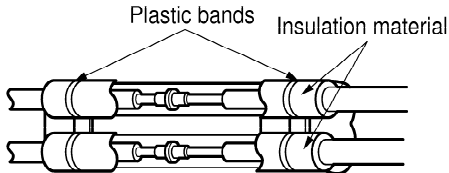

- Wrap the area which accommodates the rear piping housing section with vinyl tape.

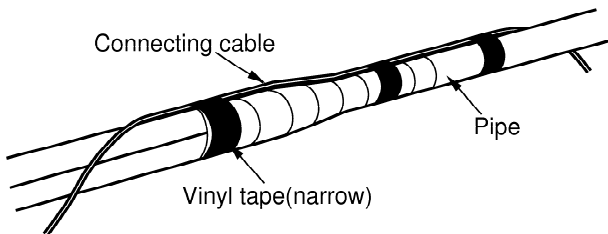
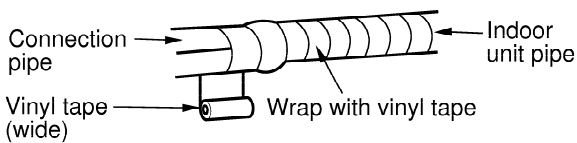

- Bundle the piping and drain hose together by wrapping them with vinyl tape over the range within which they fit into the rear piping housing section.

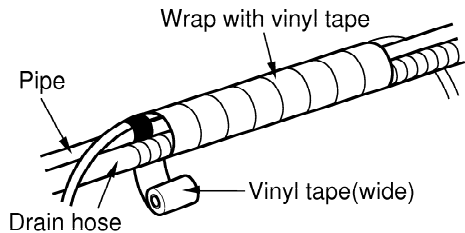

For right rear piping

- 1. Route the indoor tubing and the drain hose to the required piping hole position.**

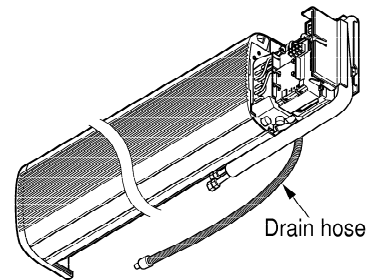

- 2. Insert the piping, drain hose and the connecting cable into the piping hole.**

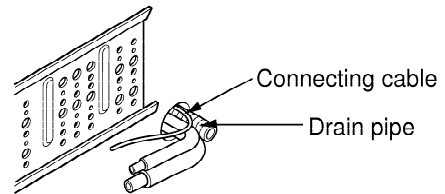

- 3. Insert the connecting cable into the indoor unit.**

- Don't connect the cable to the indoor unit.
- Make a small loop with the cable for easy connection later.

- 4. Tape the drain hose and the connecting cable.**

- Connecting cable

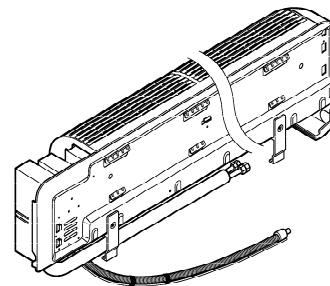

5. Indoor unit installation

- Hook the indoor unit onto the upper portion of the installation plate. (Engage the three hooks of the rear top and rear lower of the indoor unit with the upper edge and lower edge of the installation plate.) Ensure that the hooks are properly seated on the installation plate by moving it left and right.

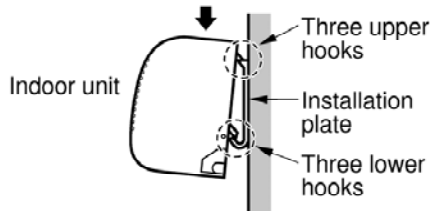
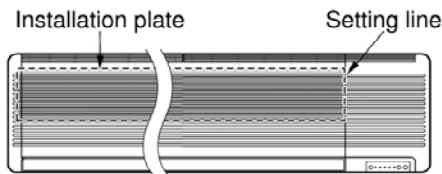

6. Connecting the pipings to the indoor unit and the drain hose to drain pipe.

- Align the center of the pipings and sufficiently tighten the flare nut by hand.

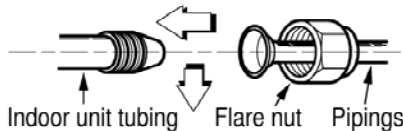

- Tighten the flare nut with a wrench.

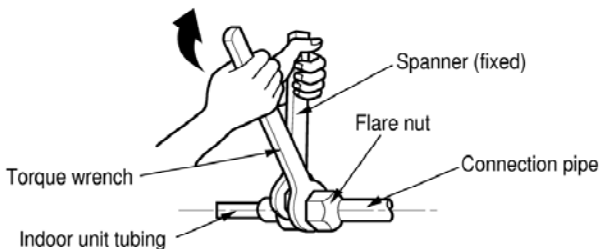

Capacity (Btu/h)	Pipe Size[Torque]	
	Suction	Evaporator
30K	5/8"[6.6kg.m]	3/8"[4.2kg.m]

- When extending the drain hose at the indoor unit, install the drain pipe.

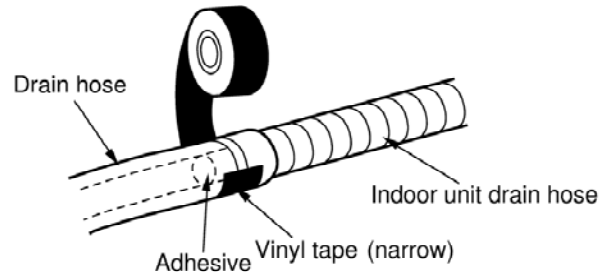

7. Wrap the insulation material around the connecting portion.

- Overlap the connection pipe heat insulation and the indoor unit pipe heat insulation material. Bind them together with vinyl tape so that there is no gap.

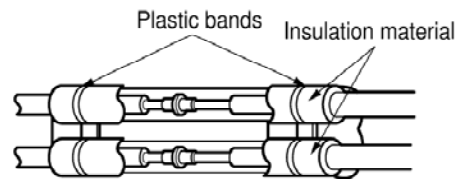

- Wrap the area which accommodates the rear piping housing section with vinyl tape.

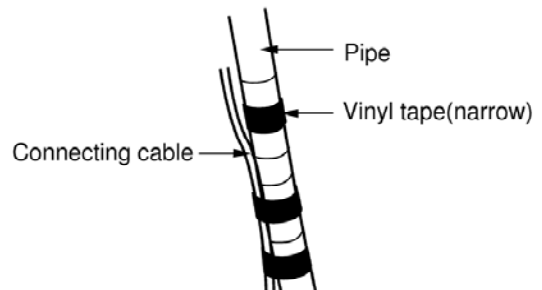
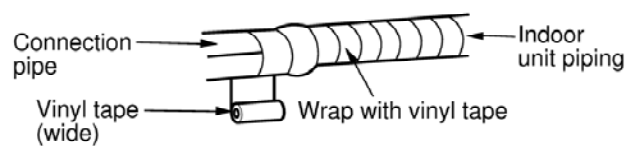

- Bundle the piping and drain hose together by wrapping them with cloth tape over the range within which they fit into the rear piping housing section.

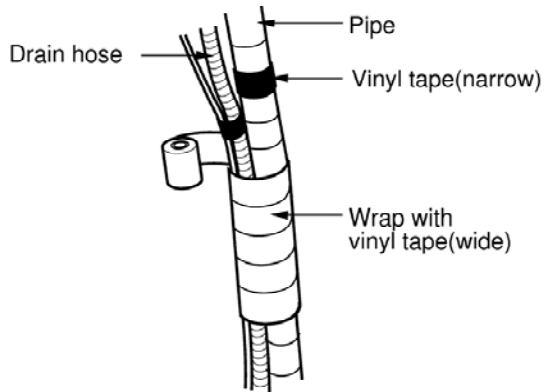

- 8. Reroute the pipings and the drain hose across the back of the chassis.

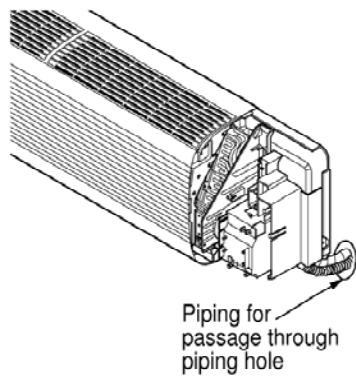

- 9. Reinstall the parts to the original position.

- Refix the lower panel to the original position.

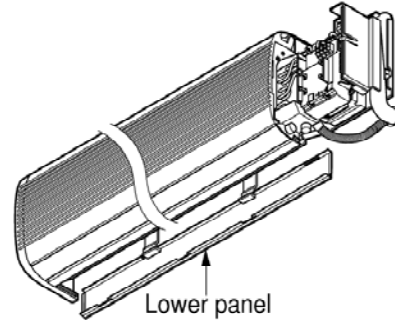

- Connect display conductor.

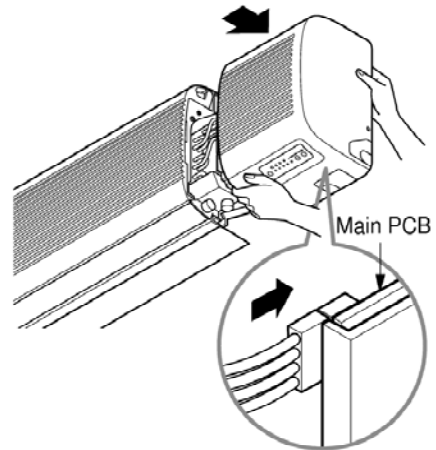

- Refix the front right side panel to the original position with the two screws.

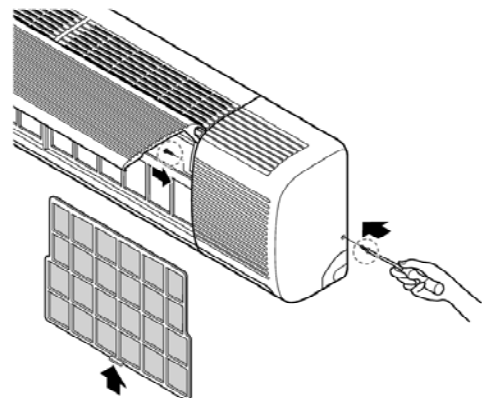

3) Connection of the drain hose

■ The drain hose can be connected at two different positions. Use the most convenient position and, if necessary, exchange the position of the drain pan, rubber cap and the drain hose.

- ❶ Drain pan
- ❷ Rubber cap
- ❸ Drain hose
- ❹ Exchange if necessary

■ Remove the drain hose.

■ Securely insert both the rubber plug and drain hose into the drain outlets. Be sure the rubber the cap is securely fastened so that there is no leakage.

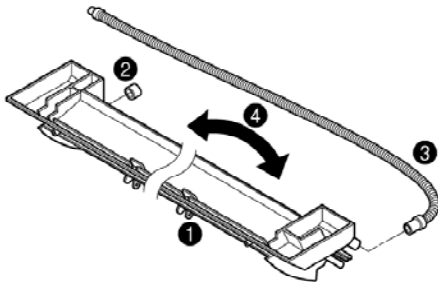

4) Connection of piping-Outdoor

1. Align the center of the pipings and sufficiently tighten the flare nut by hand.

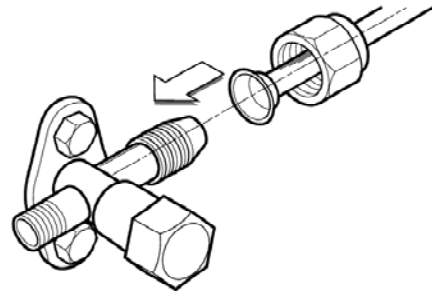

2. Finally, tighten the flare nut with torque wrench until the wrench clicks.

■ When tightening the flare nut with torque wrench, ensure the direction for tightening follows the arrow on the wrench.

Capacity (Btu/h)	Pipe Size[Torque]	
	Suction	Evaporator
30K	5/8"[6.6kg.m]	3/8"[4.2kg.m]

Outdoor unit

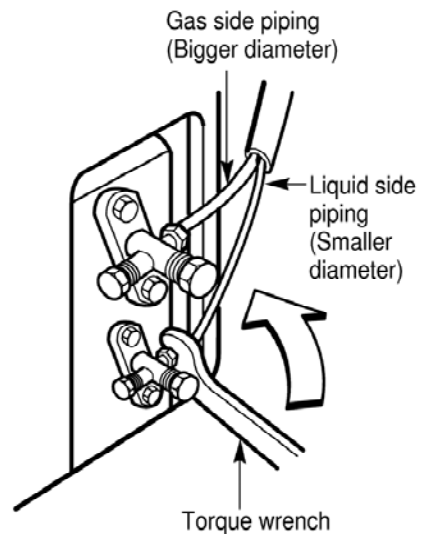

3. Connecting the cable between indoor unit and outdoor unit

- 1) Connect the cable to the indoor unit by connecting the wires to the terminals on the control board individually according to the outdoor unit connection. (Ensure that the color of the wires of the outdoor unit and the terminal No. are the same as those of the indoor unit.)

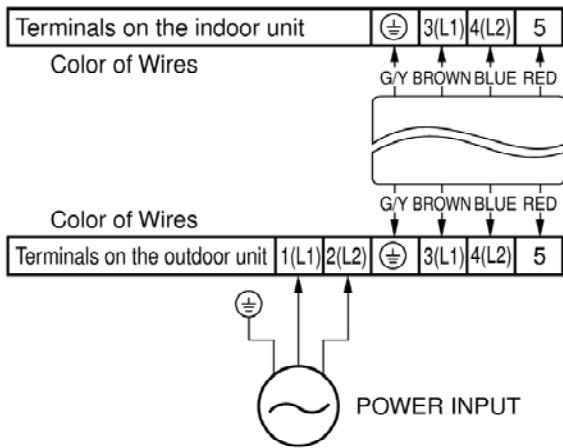

CAUTION

The power supply cord connected to the outdoor unit should be complied with the following specifications (UL and CSA recognized one).

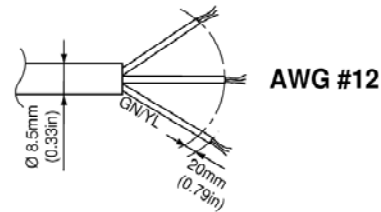

The connecting cable connected to the indoor and outdoor unit should be complied with the following specifications (UL and CSA recognized one).

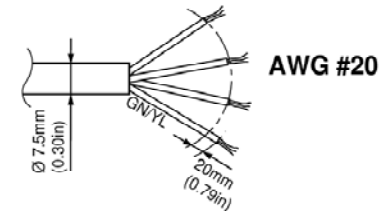

CAUTION

Wiring must be as following diagram.

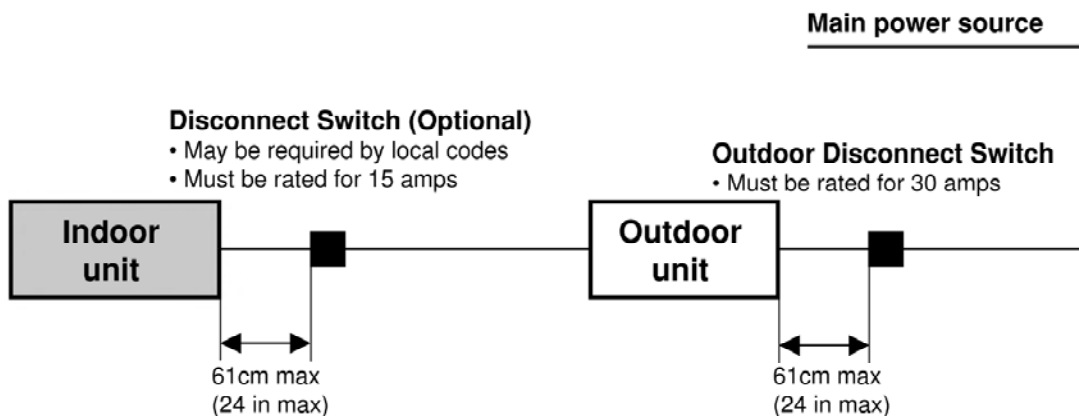

2) Connect the cable to the outdoor unit

1. Remove the control cover from the unit by loosening the screw.
Connect the wires to the terminals on the control board individually.
2. Secure the cable onto the control board with the cord clamp.
3. Refix the control cover to the original position with the screw.
4. Use a recognized circuit breaker 30A (30k, 32k), 35A (36k, 38k) between the power source and the unit. A disconnecting device to adequately disconnect all supply lines must be fitted.

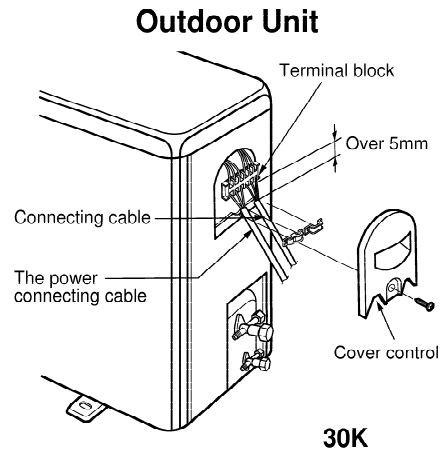

CAUTION

After the confirmation of the above conditions, prepare the wiring as follows:

- 1) **Never fail to have an individual power circuit specifically for the air conditioner. As for the method of wiring, be guided by the circuit diagram posted on the inside of control cover.**
- 2) **The screw which fasten the wiring in the casing of electrical fittings are liable to come loose from vibrations to which the unit is subjected during the course of transportation. Check them and make sure that they are all tightly fastened. (If they are loose, it could cause burn-out of the wires.)**
- 3) **Specification of power source.**
- 4) **Confirm that electrical capacity is sufficient.**
- 5) **See to that the starting voltage is maintained at more than 90 percent of the rated voltage marked on the name plate.**
- 6) **Confirm that the cable thickness is as specified in the power source specification. (Particularly note the relation between cable length and thickness. (Refer to page 30))**
- 7) **Always install an earth leakage circuit breaker in a wet or moist area.**
- 8) **The following would be caused by voltage drop.**
 - Vibration of a magnetic switch, which will damage the contact point, fuse breaking, disturbance of the normal function of the overload.
- 9) **The means for disconnection from a power supply shall be incorporated in the fixed wiring and have an air gap contact separation of at least 3mm in each active(phase) conductors.**

1) Checking the drainage

1. Remove the right side panel.

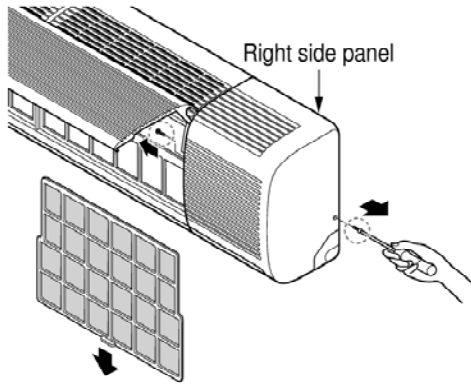

2. Remove the lower panel by the arrow.

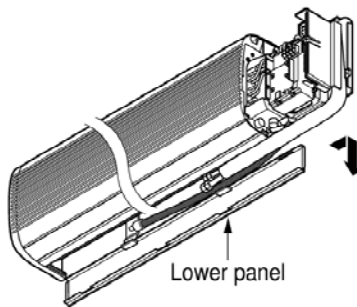

3. Remove the left side panel. (Remove the two screws.)

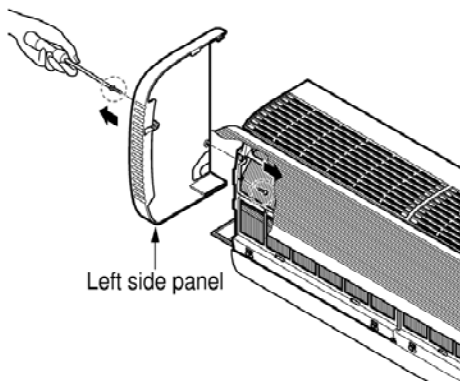

4. To check the drainage.

- Pour a glass of water on the drain pan.
- Ensure the water flows through the drain hose of the indoor unit without any leakage and goes out the drain exit.

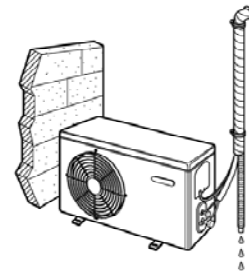
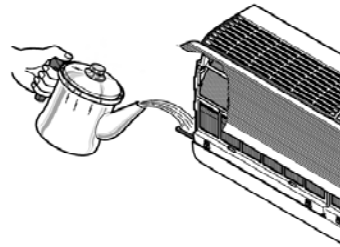

5. Drain piping

- The drain hose should point downward for easy drain flow.

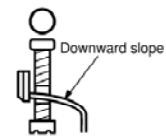

- Do not make drain piping.

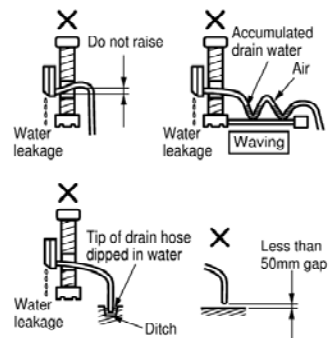

2) Form the piping

1. Form the piping by wrapping the connecting portion of the indoor unit with insulation material and secure it with two kinds of vinyl tapes.

- If you want to connect an additional drain hose, the end of the drain outlet should be routed above the ground. Secure the drain hose appropriately.

2. In cases where the outdoor unit is installed below the indoor unit perform the following.

- Tape the piping, drain hose and connecting cable from down to up.
- Secure the tapped piping along the exterior wall using saddle or equivalent.

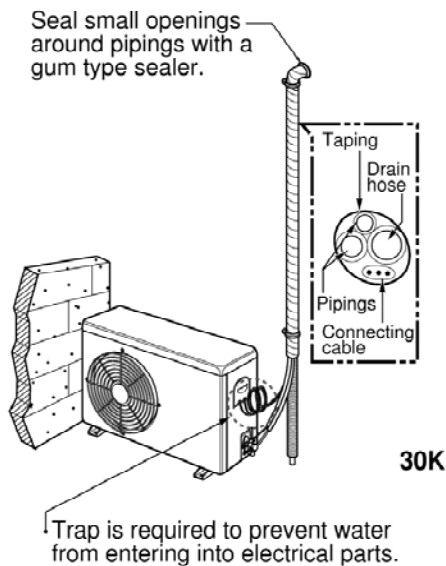

3. In cases where the Outdoor unit is installed above the Indoor unit perform the following.

- Tape the piping and connecting cable from down to up.
- Secure the taped piping along the exterior wall. Form a trap to prevent water entering the room.
- Fix the piping onto the wall by saddle or equivalent.

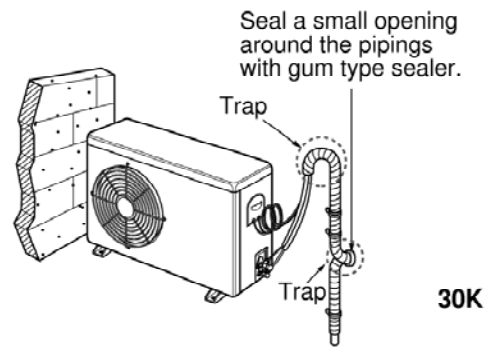

4. AIR PURGING

1) Air purging

Air and moisture remaining in the refrigerant system have undesirable effects as indicated below.

- Pressure in the system rises.
- Operating current rises.
- Cooling(or heating) efficiency drops.
- Moisture in the refrigerant circuit may freeze and block capillary tubing.
- Water may lead to corrosion of parts in the refrigeration system.

Therefore, the indoor unit and tubing between the indoor and outdoor unit must be leak tested and evacuated to remove any noncondensables and moisture from the system.

2) Air purging with vacuum pump

1. Preparation

- Check that each tube(both liquid and gas side tubes) between the indoor and outdoor units have been properly connected and all wiring for the test run has been completed. Remove the service valve caps from both the gas and the liquid side on the outdoor unit. Note that both the liquid and the gas side service valves on the outdoor unit are kept closed at this stage.

2. Leak test

- Connect the manifold valve(with pressure gauges) and dry nitrogen gas cylinder to this service port with charge hoses.

CAUTION

Be sure to use a manifold valve for air purging. If it is not available, use a stop valve for this purpose. The "Hi" knob of the manifold valve must always be kept close.

- Pressurize the system to no more than 150 P.S.I.G. with dry nitrogen gas and close the cylinder valve when the gauge reading reached 150 P.S.I.G. Next, test for leaks with liquid soap.

CAUTION

To avoid nitrogen entering the refrigerant system in a liquid state, the top of the cylinder must be higher than its bottom when you pressurize the system. Usually, the cylinder is used in a vertical standing position.

- Do a leak test of all joints of the tubing(both indoor and outdoor) and both gas and liquid side service valves. Bubbles indicate a leak. Be sure to wipe off the soap with a clean cloth.
- After the system is found to be free of leaks, relieve the nitrogen pressure by loosening the charge hose connector at the nitrogen cylinder. When the system pressure is reduced to normal, disconnect the hose from the cylinder.

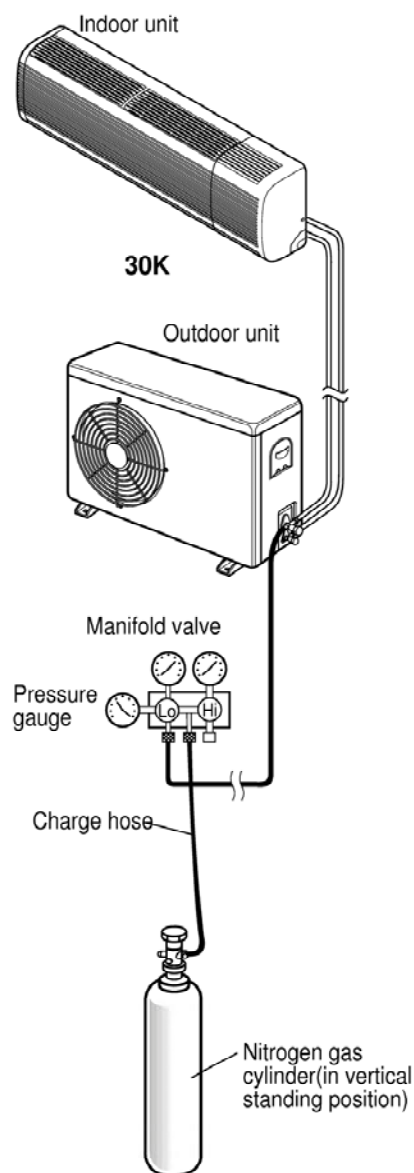

Soap water method

- (1) Remove the caps from the gas side and liquid side valves.
- (2) Remove the service-port cap from the gas side valve.
- (3) To open the gas side valve turn the valve stem counter-clockwise approximately 90°, wait for about 2~3 sec, and close it.
- (4) Apply a soap water or a liquid neutral detergent on the indoor unit connection or outdoor unit connections by a soft brush to check for leakage of the connecting points of the piping.
- (5) If bubbles come out, the pipes have leakage.

3. Evacuation

- Connect the charge hose end described in the preceding steps to the vacuum pump to evacuate the tubing and indoor unit. Confirm the "Lo" knob of the manifold valve is open. Then, run the vacuum pump. The operation time for evacuation varies with tubing length and capacity of the pump. The following table shows the time required for evacuation.

Required time for evacuation when 30 gal/h vacuum pump is used	
If tubing length is less than 10m (33 ft).	If tubing length is longer than 10m (33 ft).
10 min. or more	15 min. or more

- When the desired vacuum is reached, close the "Lo" knob of the manifold valve and stop the vacuum pump.

4. Finishing the job

- With a service valve wrench, turn the valve stem of liquid side valve counter-clockwise to fully open the valve.
- Turn the valve stem of gas side valve counter-clockwise to fully open the valve.
- Loosen the charge hose connected to the gas side service port slightly to release the pressure, then remove the hose.
- Replace the flare nut and its bonnet on the gas side service port and fasten the flare nut securely with an adjustable wrench. This process is very important to prevent leakage from the system.
- Replace the valve caps at both gas and liquid side service valves and fasten them tight. This completes air purging with a vacuum pump. The air conditioner is now ready to test run.

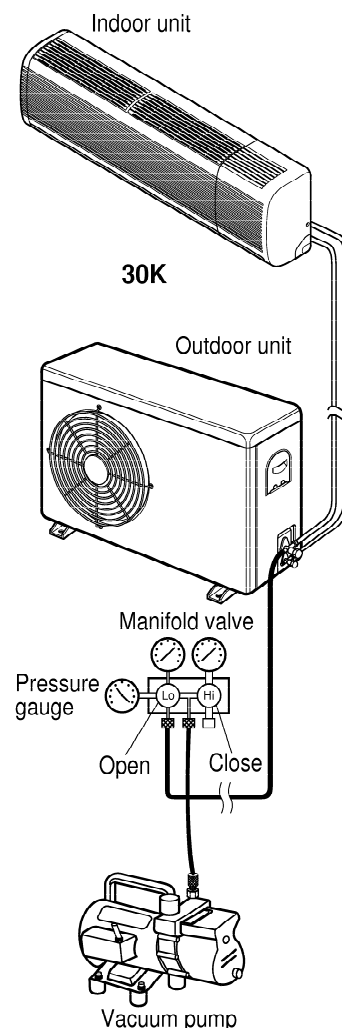
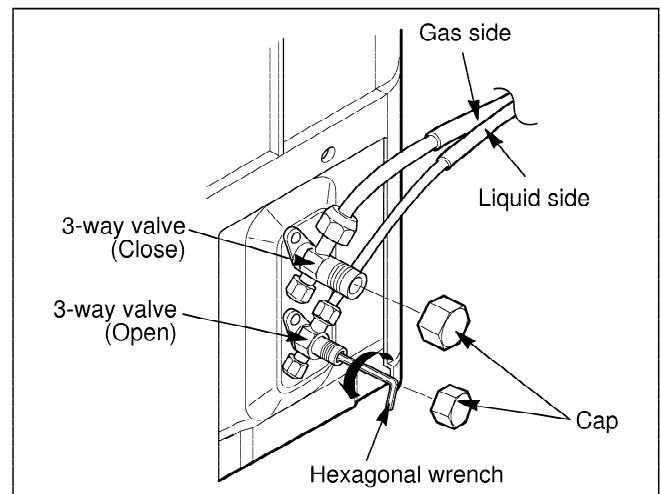

5. TEST RUNNING

1. Check that all tubing and wiring have been properly connected.
2. Check that the gas and liquid side service valves are fully open.

1. Prepare remote control

- 1 Remove the battery cover by pulling it according to the arrow direction.
- 2 Insert new batteries making sure that the (+) and (-) of battery are installed correctly.
- 3 Reattach the cover by pushing it back into position.

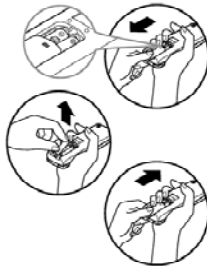

NOTE:

- Use 2 AAA(1.5volt) batteries. Do not use rechargeable batteries.
- Remove the batteries from the remote control if the system is not going to be used for a long time.

2. Settlement of outdoor unit

- Anchor the outdoor unit with a bolt and nut(ø10mm) tightly and horizontally on a concrete or rigid mount.
- When installing on the wall, roof or rooftop, anchor the mounting base securely with a nail or wire assuming the influence of wind and earthquake.
- In the case when the vibration of the unit is conveyed to the hose, secure the unit with an anti-vibration rubber.

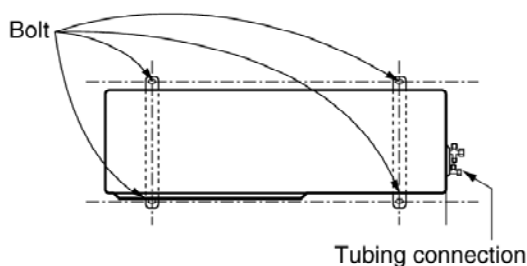

3. Evaluation of the performance

Operate unit for 15~20 minutes, then check the system refrigerant charge:

1. Measure the pressure of the gas side service valve.
2. Measure the temperature of the intake and discharge of air.
3. Ensure the difference between the intake temperature and the discharge is more than 8°C (Cooling) or reversely (Heating).

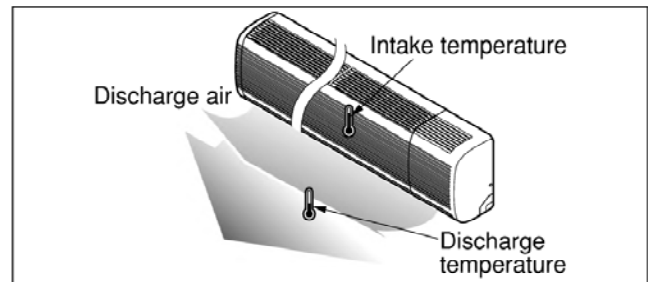

4. For reference; the gas side pressure of optimum condition is as below.(Cooling)

Outside ambient TEMP	The pressure of the gas side service valve
35°C(95°F)	4~5kg/cm ² G(56.8~71.0 P.S.I.G.)

NOTE: If the actual pressure are higher than shown, the system is most likely over-charged, and charge should be removed. If the actual pressure are lower than shown, the system is most likely under-charged, and charge should be added. The air conditioner is now ready for use.

NOTE: Heating capacity decreases as outdoor temperature decreases.
The unit can work below to 14F without unit out or system shut down.

PUMP DOWN

This is performed when the unit is to be relocated or the refrigerant circuit is serviced.

Pump Down means collecting all refrigerant in the outdoor unit without loss in refrigerant gas.

CAUTION:

Be sure to perform Pump Down procedure with the unit cooling mode.

Pump Down Procedure

1. Connect a low-pressure gauge manifold hose to the charge port on the gas side service valve.
2. Open the gas side service valve halfway and purge the air from the manifold hose using the refrigerant gas.
3. Close the liquid side service valve(all the way in).
4. Turn on the unit's operating switch and start the cooling operation.
5. When the low-pressure gauge reading becomes 1 to 0.5kg/cm² G(14.2 to 7.1 P.S.I.G.), fully close the gas side valve stem and then quickly turn off the unit. At that time, Pump Down has been completed and all refrigerant gas will have been collected in the outdoor unit.

Operation

(1) Name and Function-Remote Control (Cooling Models)

Remote Controller

Signal transmitter.

Transmits the signals to the room air conditioner.

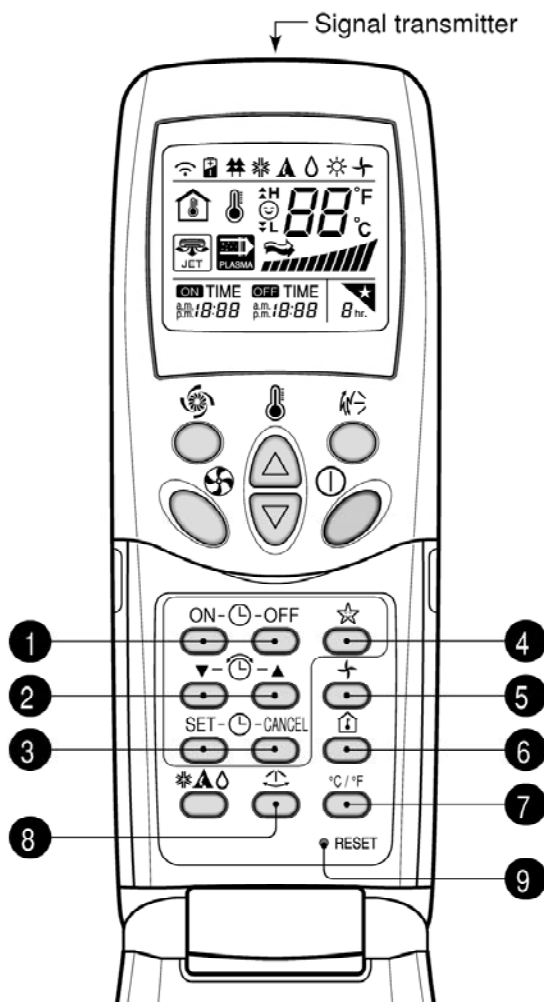

- 1 ON/OFF TIMER BUTTONS**
Used to set the time of starting and stopping operation.
- 2 TIME SETTING BUTTONS**
Used to adjust the time.
- 3 TIMER SET/CANCEL BUTTONS**
Used to set the timer when the desired time is obtained and to cancel the Timer operation.
- 4 SLEEP MODE AUTO BUTTON**
Used to set Sleep Mode Auto operation.
- 5 AIR CIRCULATION BUTTON**
Used to circulate the room air without cooling or heating (turns indoor fan on/off).
- 6 ROOM TEMPERATURE CHECKING BUTTON**
Used to check the room temperature.
- 7 °C / °F SELECTING BUTTON**
Choose temperature unit °C or °F alternatively.
- 8 HORIZONTAL AIRFLOW DIRECTION CONTROL BUTTON (NOT ON ALL MODELS)**
Used to set the desired horizontal airflow direction.
- 9 RESET BUTTON**
Used prior to resetting time or after replacing batteries.

(2) Name and Function-Remote Control (Heat Pump Models)

Remote Controller

Signal transmitter.

Transmits the signals to the room air conditioner.

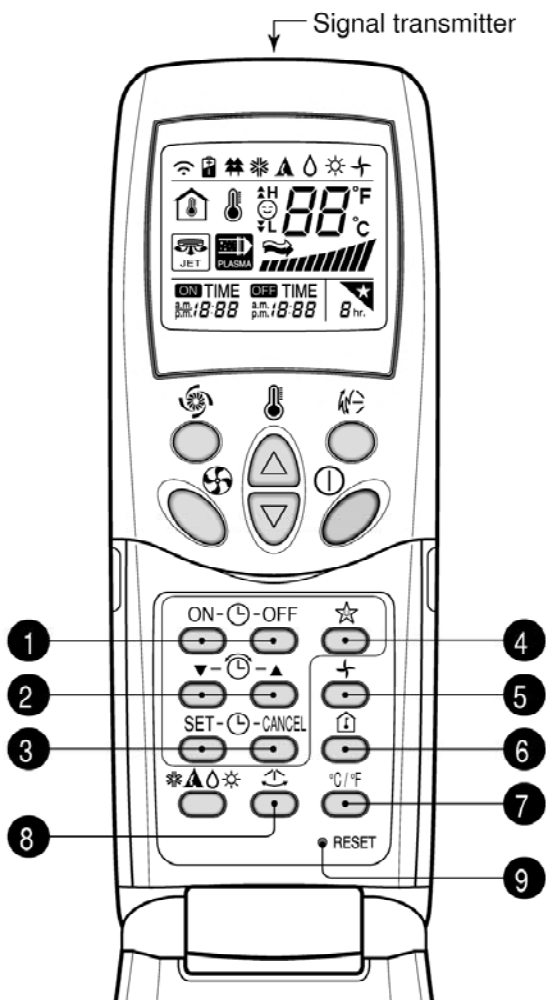

- 1 ON/OFF TIMER BUTTONS**
Used to set the time of starting and stopping operation.
- 2 TIME SETTING BUTTONS**
Used to adjust the time.
- 3 TIMER SET/CANCEL BUTTONS**
Used to set the timer when the desired time is obtained and to cancel the Timer operation.
- 4 SLEEP MODE AUTO BUTTON**
Used to set Sleep Mode Auto operation.
- 5 AIR CIRCULATION BUTTON**
Used to circulate the room air without cooling or heating (turns indoor fan on/off).
- 6 ROOM TEMPERATURE CHECKING BUTTON**
Used to check the room temperature.
- 7 °C / °F SELECTING BUTTON**
Choose temperature unit °C or °F alternatively.
- 8 HORIZONTAL AIRFLOW DIRECTION CONTROL BUTTON (NOT ON ALL MODELS)**
Used to set the desired horizontal airflow direction.
- 9 RESET BUTTON**
Used prior to resetting time or after replacing batteries.

Disassembly of the parts (Indoor unit)

Warning :

Disconnect the unit from power supply before making any checks.

Be sure the power switch is set to "OFF".

1. To remove the Grille from the Chassis.

- ❶ Remove the 2 screws of right side panel.

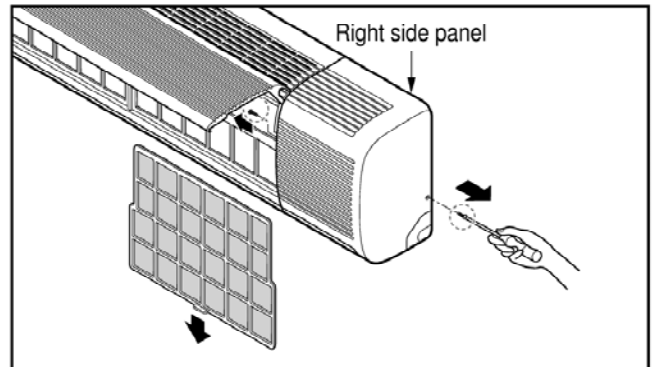

- ❷ Remove the front right side panel by the arrow.

- The connector can be disconnected by pulling it while pressing the connector's hook.
- Remove the 1 screw for fixing low panel.

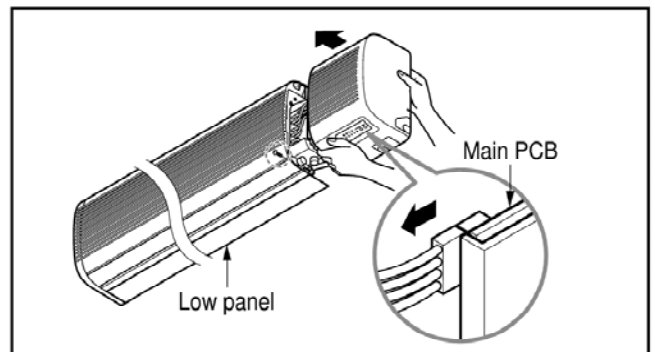

- ❸ Remove the lower panel by the arrow.

- Take care not to scratch the wall and mat to drop.

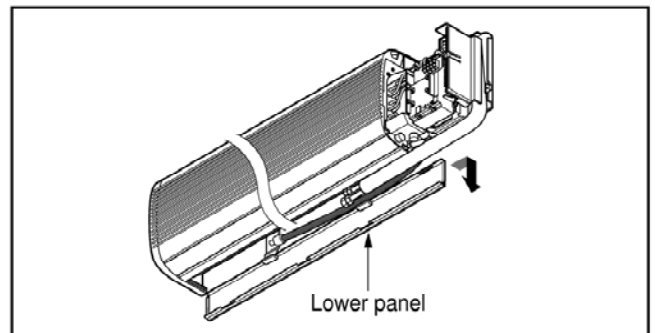

- ❹ Remove the left side pane.
(Remove the 2 screws.)

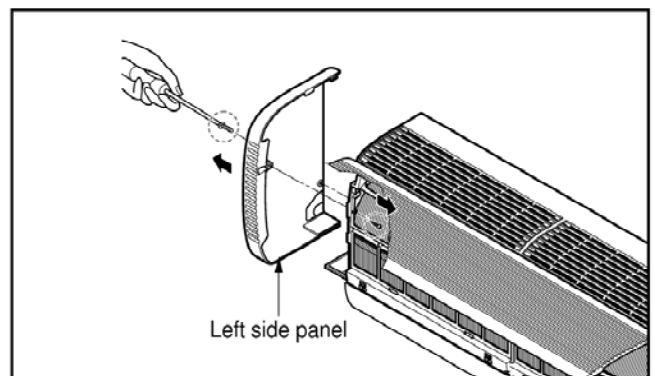

④ Remove the grille from the chassis.

- Remove the 4 securing screws.(30K, 32K)
- Remove the 5 securing screws.(36K, 38K)
- To remove the Grille, pull the lower left and right side of the grille toward you (slightly tilted) and lift it straight upward.

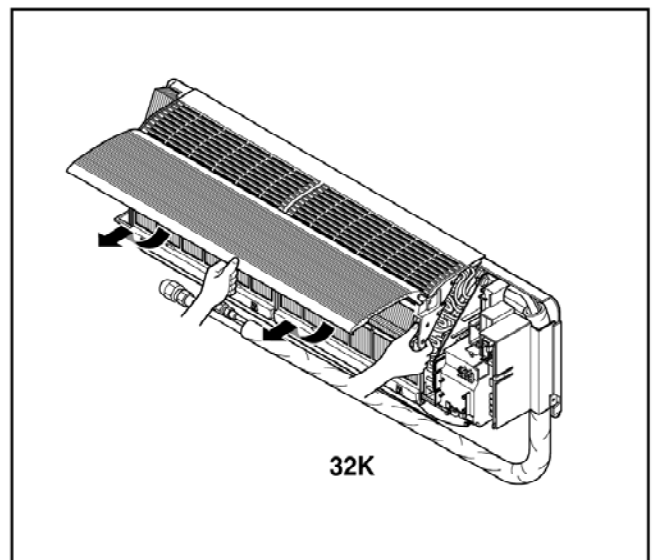
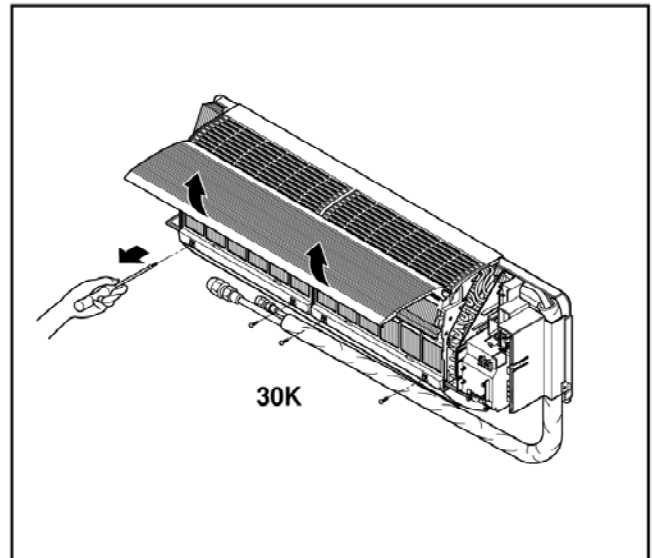

2. To remove the sensor, housing connector, earth conductor and step motor conductor with sensor holder, Motor, Evaporator and P.C.B.

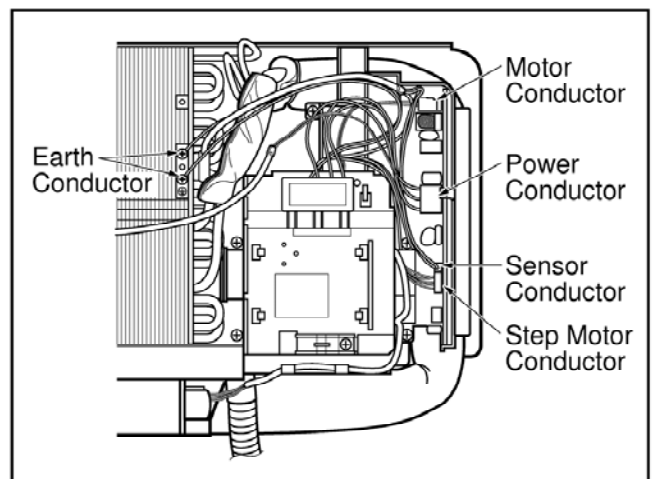

3. To remove the Control Box.

- Remove the 5 securing screws.
- Pull the control box out from the chassis carefully.

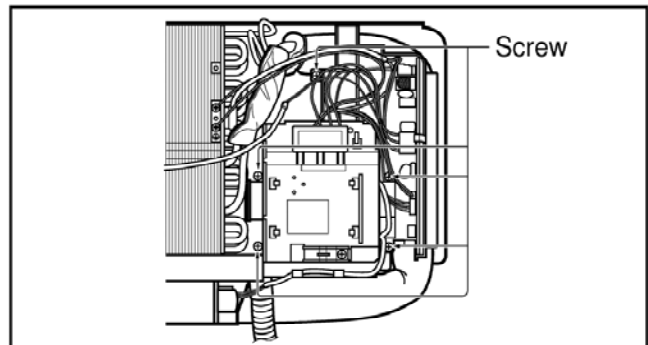

4. To remove the Discharge Grille.

- Remove the 3 securing screw.
- Pressing the right side of the discharge grille downward slightly, unhook the discharge grille.
- Pull the discharge grille out from the chassis carefully.

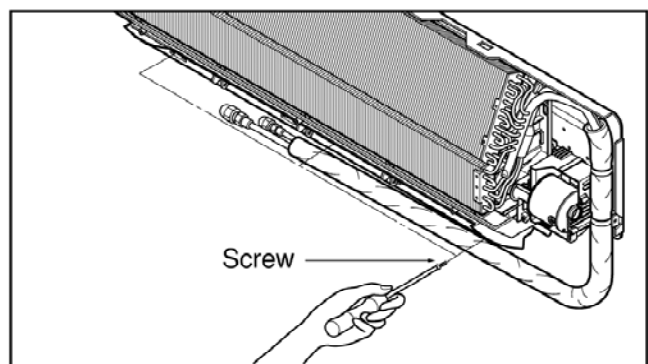

5. To remove the Evaporator.

- Remove 3 screws securing the evaporator(at the left 2EA, at the right 1EA).
- Remove 2 screws securing the evaporator clamp.

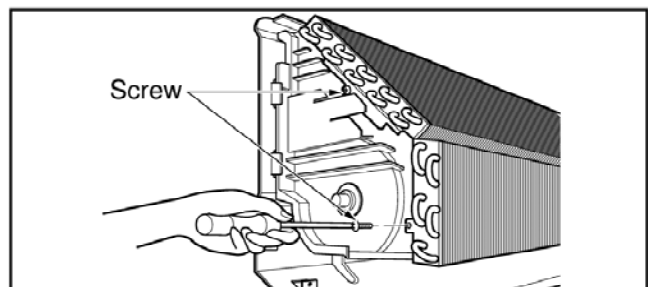
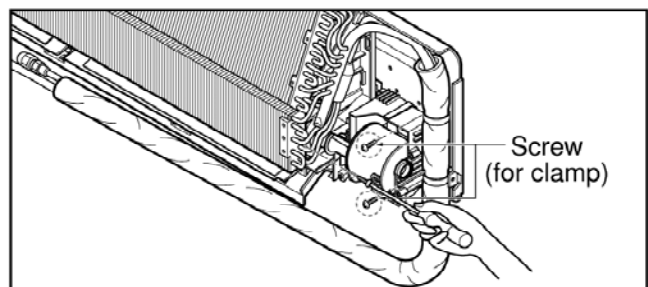

- Unhook the tab on the right inside of the chassis at the same time, slightly pull the evaporator toward you until the tab is clear of the slot.

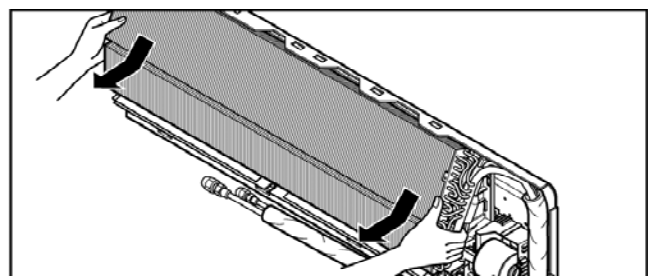

6. To remove the Fan motor

- Loosen the screw securing the cross-flow fan to the fan motor (do not remove).

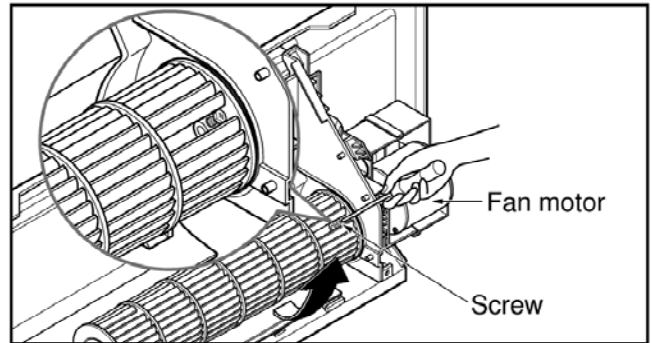

- Loosen the screw securing the mount motor.

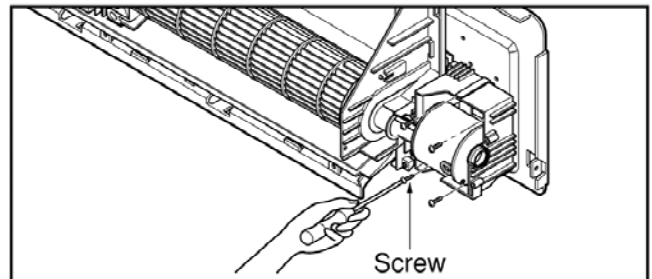

- Separate the fan motor from the cross-flow fan.
- Take care not to drop the motor.

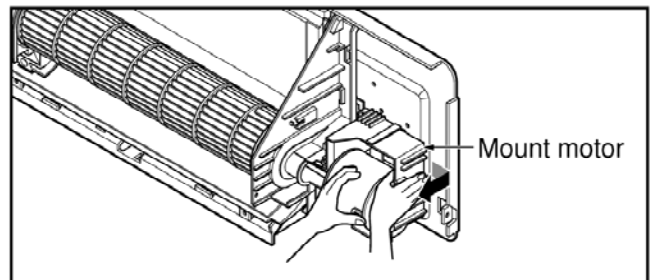

7. To remove the Cross-Flow Fan

- Loosen the screw securing the holder bearing.
- Lift up the cross-flow fan.

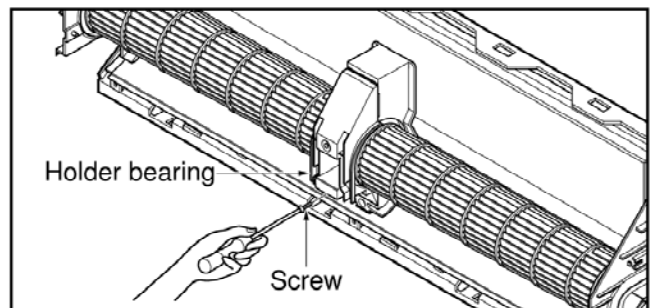
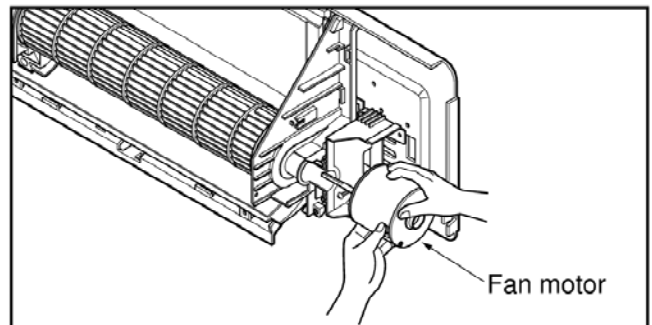

3-way Valve

1. Pump down

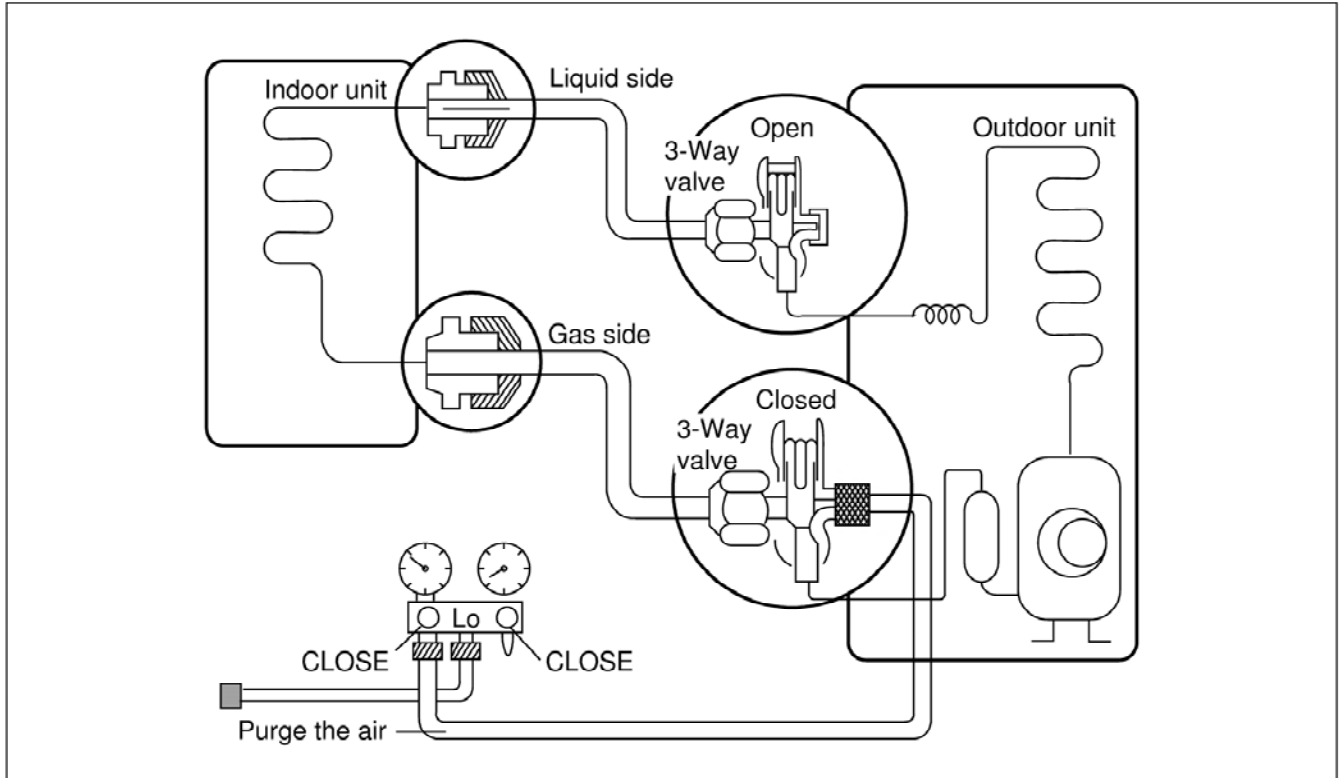

• Procedure

- (1) **Confirm that both liquid side and gas side valves are set to the open position.**
 - Remove the valve stem caps and confirm that the valve stems are in the raised position.
 - Be sure to use a hexagonal wrench to operate the valve stems.
- (2) **Operate the unit for 10 to 15 minutes.**
- (3) **Stop operation and wait for 3 minutes, then connect the charge set to the service port of the Gas side valve.**
 - Connect the charge hose to the service port.
- (4) **Air purging of the charge hose.**
 - Open the low-pressure valve on the charge set slightly to air purge from the charge hose.
- (5) **Set the liquid side valve to the closed position.**
- (6) **Operate the air conditioner in cooling mode and stop it when the gauge indicates 1kg/cm²g.**
- (7) **Immediately set the Gas side valve to the closed position.**
 - Do this quickly so that the gauge ends up indicating 3 to 5kg/cm²g.
- (8) **Disconnect the charge set, and mount the Liquid side and Gas side valve's stem nuts and the service port nut.**
 - Use torque wrench to tighten the service port nut to a torque of 1.8 kg.m.
 - Be sure to check for gas leakage.

1) Re-air purging (Re-installation)

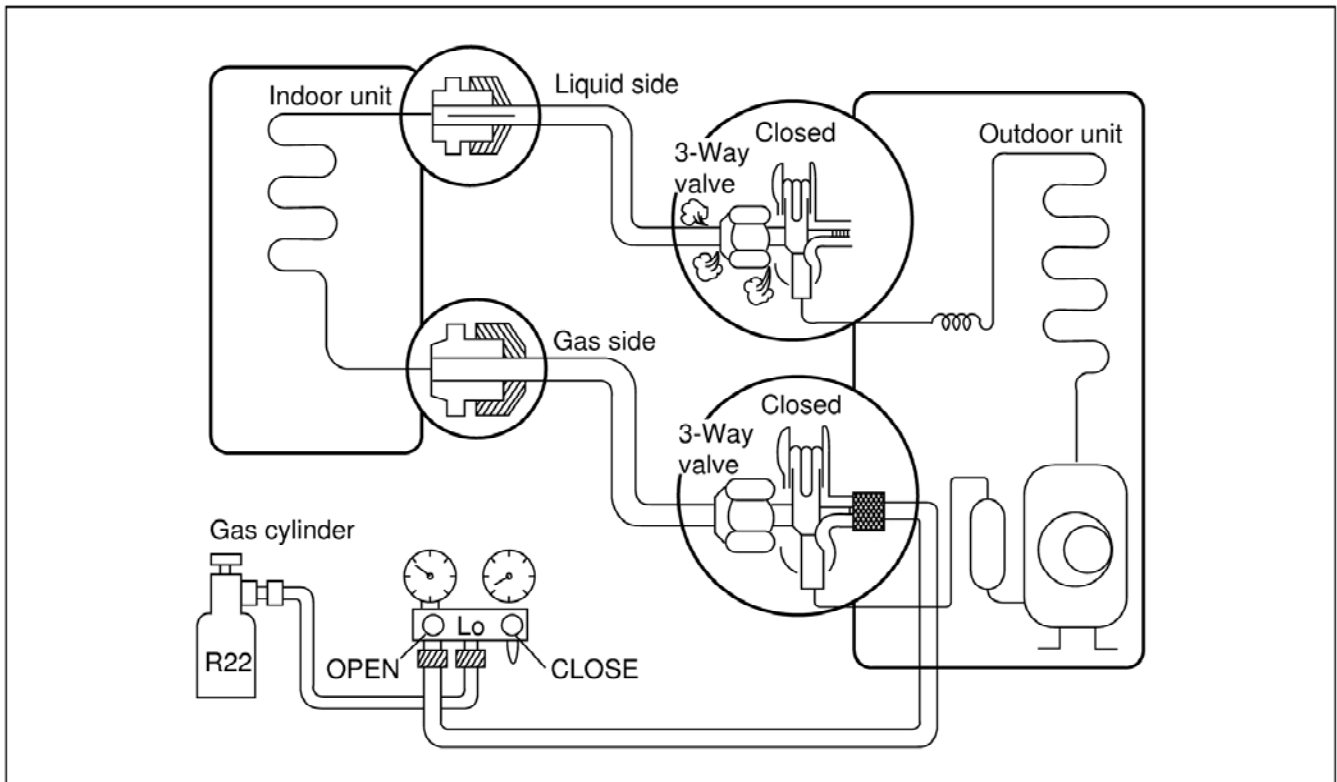

• Procedure

- (1) **Confirm that both the liquid side valve and the gas side valve are set to the closed position.**
- (2) **Connect the charge set and a gas cylinder to the service port of the Gas side valve.**
 - Leave the valve on the gas cylinder closed.
- (3) **Air purging.**
 - Open the valves on the gas cylinder and the charge set. Purge the air by loosening the flare nut on the liquid side valve approximately 45° for 3 seconds then closing it for 1 minute; repeat 3 times.
 - After purging the air, use a torque wrench to tighten the flare nut on liquid side valve.
- (4) **Check for gas leakage.**
 - Check the flare connections for gas leakage.
- (5) **Discharge the refrigerant.**
 - Close the valve on the gas cylinder and discharge the refrigerant until the gauge indicates 3 to 5 kg/cm²g.
- (6) **Disconnect the charge set and the gas cylinder, and set the Liquid side and Gas side valves to the open position.**
 - Be sure to use a hexagonal wrench to operate the valve stems.
- (7) **Mount the valve stem nuts and the service port nut.**
 - Use torque wrench to tighten the service port nut to a torque of 1.8 kg.m.
 - Be sure to check for gas leakage.

* **CAUTION:**
Do not leak the gas in the air during Air Purging.

2) Balance refrigerant of the 3-way valve (Gas leakage)

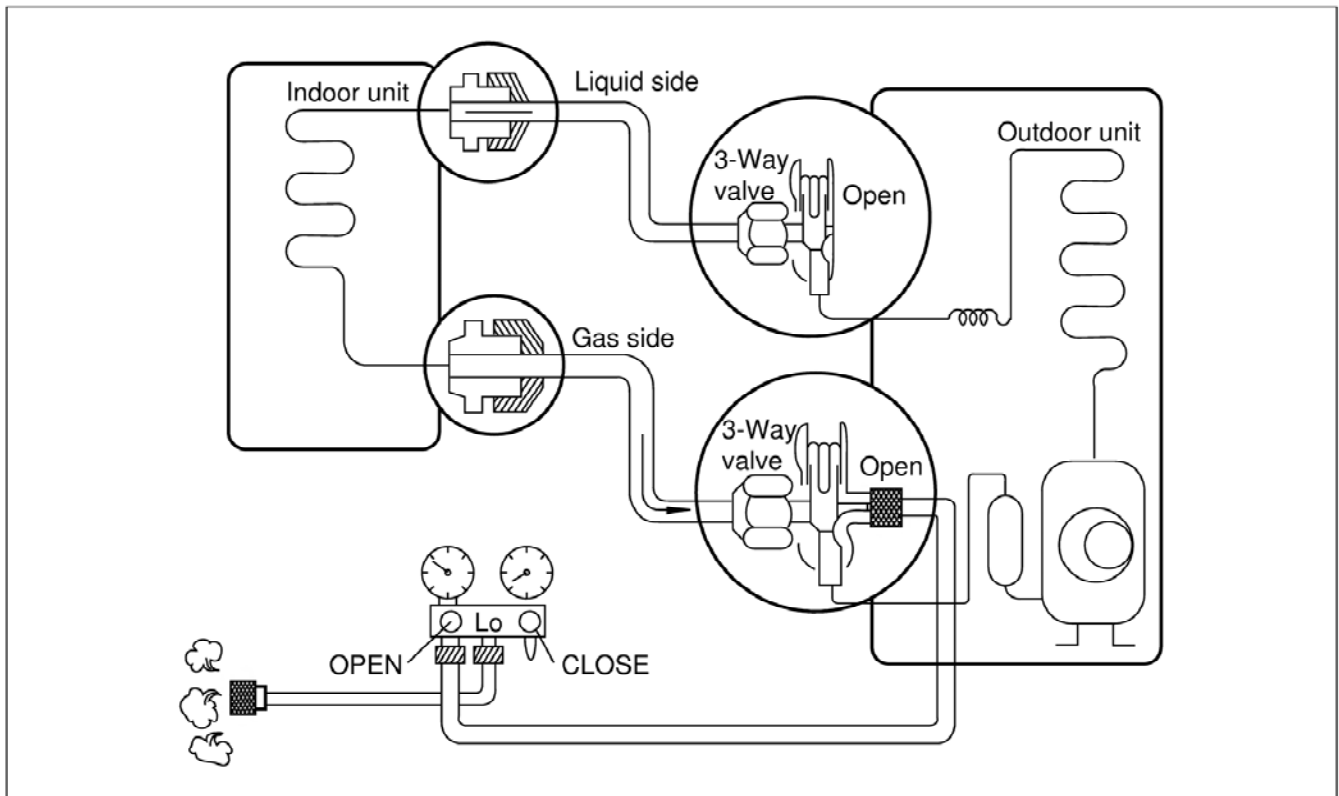

• Procedure

- (1) Confirm that both the liquid side and gas side valves are set to the back seat.
- (2) Connect the charge set to the 3-way valve's port.
 - Leave the valve on the charge set closed.
 - Connect the charge hose to the service port.
- (3) Open the valve (Lo side) on the charge set and discharge the refrigerant until the gauge indicates 0 kg/cm²G.
 - If there is no air in the refrigerant cycle (the pressure when the air conditioner is not running is higher than 1 kg/cm²G), discharge the refrigerant until the gauge indicates 0.5 to 1 kg/cm²G. If this is the case, it will not be necessary to apply a evacuation.
 - Discharge the refrigerant gradually; if it is discharged too suddenly, the refrigeration oil will also be discharged.

2. Evacuation

(All amount of refrigerant leaked)

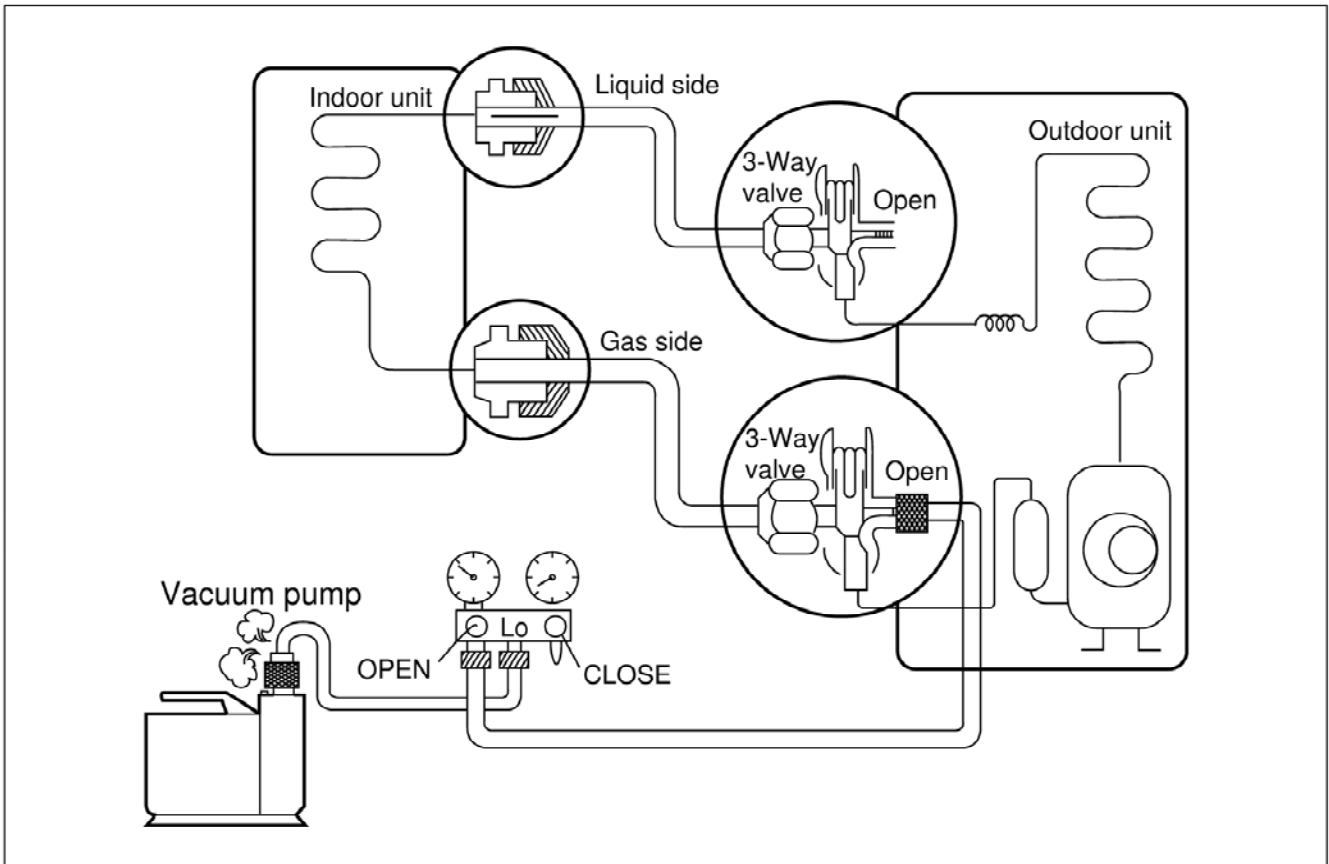

• Procedure

- (1) Connect the vacuum pump to the center hose of charge set center hose
- (2) Evacuation for approximately one hour.
 - Confirm that the gauge needle has moved toward -76 cmHg (vacuum of 4 mmHg or less).
- (3) Close the valve (Lo side) on the charge set, turn off the vacuum pump, and confirm that the gauge needle does not move (approximately 5 minutes after turning off the vacuum pump).
- (4) Disconnect the charge hose from the vacuum pump.
 - Vacuum pump oil.
If the vacuum pump oil becomes dirty or depleted, replenish as needed.

3. Gas Charging

(After Evacuation)

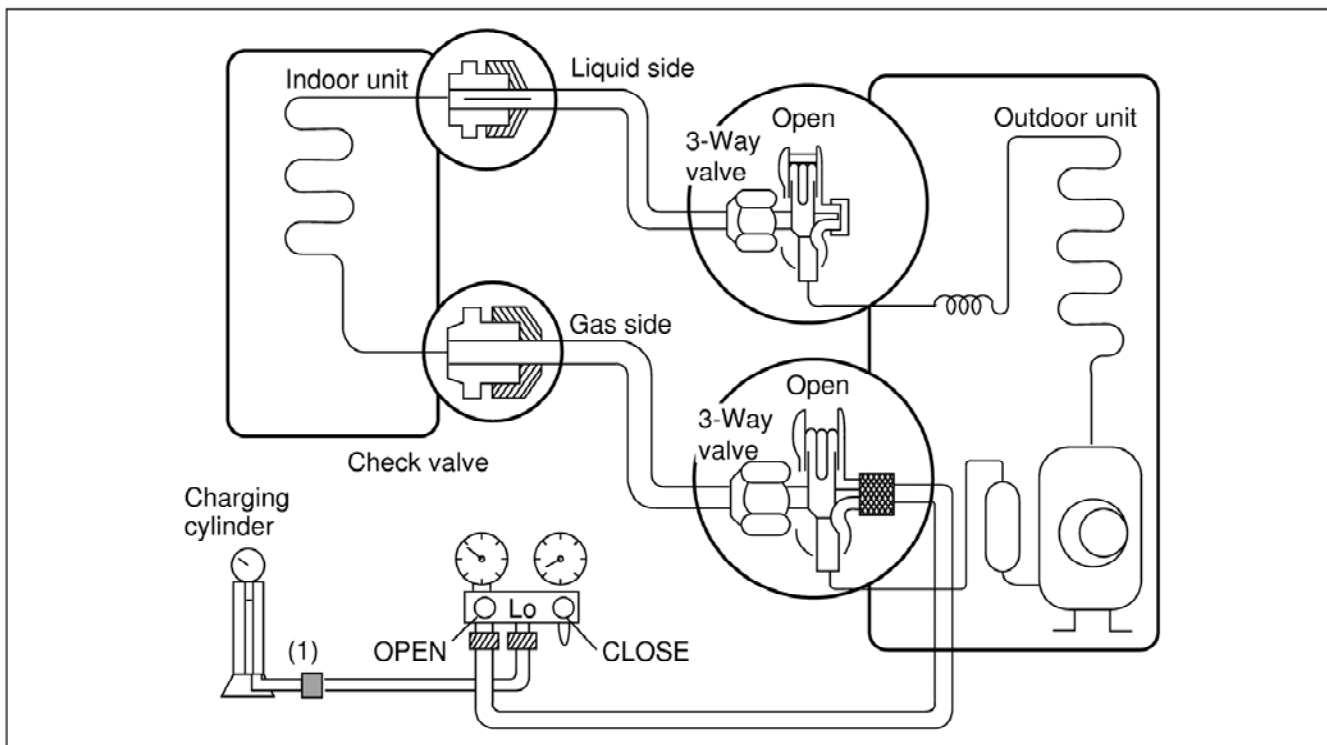

• Procedure

(1) Connect the charge hose to the charging cylinder.

- Connect the charge hose which you disconnected from the vacuum pump to the valve at the bottom of the cylinder.
- If you are using a gas cylinder, also use a scale and reverse the cylinder so that the system can be charged with liquid.

(2) Purge the air from the charge hose.

- Open the valve at the bottom of the cylinder and press the check valve on the charge set to purge the air. (Be careful of the liquid refrigerant). The procedure is the same if using a gas cylinder.

(3) Open the valve (Lo side on the charge set and charge the system with liquid refrigerant.

- If the system can not be charged with the specified amount of refrigerant, it can be charged with a little at a time (approximately 150g each time) while operating the air conditioner in the cooling cycle; however, one time is not sufficient, wait approximately 1 minute and then repeat the procedure (pumping down-pin).

This is different from previous procedures.

Because you are charging with liquid refrigerant from the gas side, absolutely do not attempt to charge with larger amounts of liquid refrigerant while operating the air conditioner.

(4) Immediately disconnect the charge hose from the 3-way valve's service port.

- Stopping partway will allow the gas to be discharged.
- If the system has been charged with liquid refrigerant while operating the air conditioner turn off the air conditioner before disconnecting the hose.

(5) Mount the valve stem nuts and the service port nut.

- Use torque wrench to tighten the service port nut to a torque of 1.8 kg.m.
- Be sure to check for gas leakage.

Cycle Troubleshooting Guide

Trouble analysis

1. Check temperature difference between intake and discharge air and operating current.

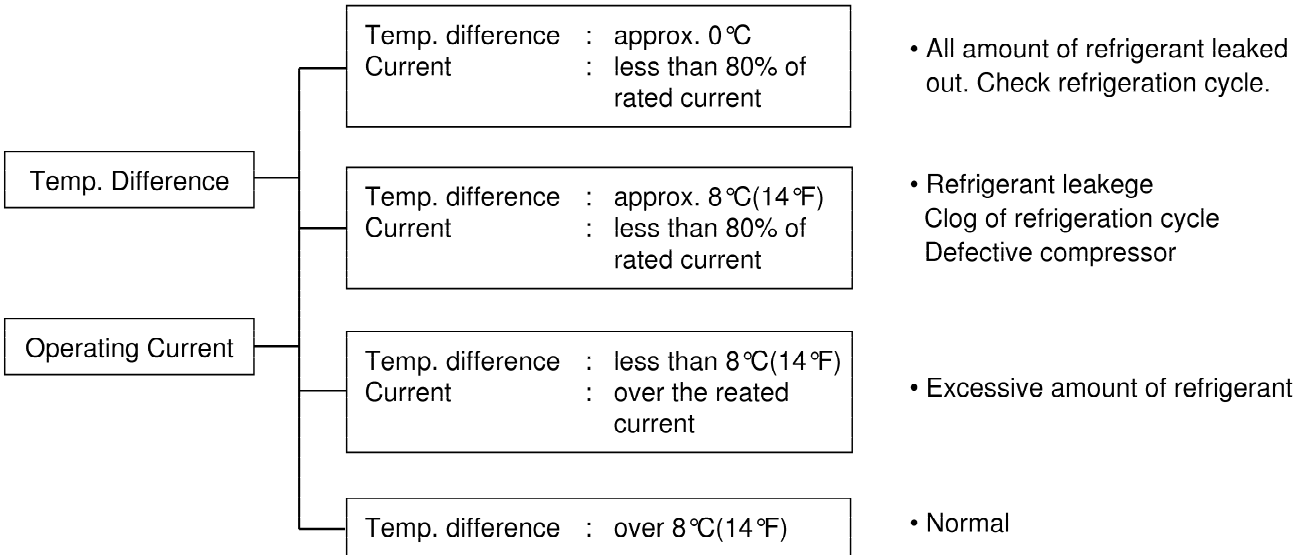

Notice :

Temperature difference between intake and discharge air depends on room air humidity. When the room air humidity is relatively higher, temperature difference is smaller. When the room air humidity is relatively lower temperature difference is larger.

2. Check temperature and pressure of refrigeration cycle.

Suction pressure (Compared with the normal value)	Temperature (Compared with the normal valve)	Cause of Trouble	Description
Higher	High	Defective compressor Defective 4-way reverse valve	Current is low.
	Normal	Excessive amount of refrigerant	High pressure does not quickly rise at the beginning of operation.
Lower	Higher	Insufficient amount of refrigerant (Leakage)	Current is low.
		Clogging	Current is low.

Notice :

1. The suction pressure is usually 4.5~6.0 kg/cm²G(Cooling) at normal condition.
2. The temperature can be measured by attaching the thermometer to the low pressure tubing and wrap it with putty.

Electronic Parts Troubleshooting Guide

1. Product does not operate at all.

(* Refer to Electronic Control Device drawing and Schematic diagram.)

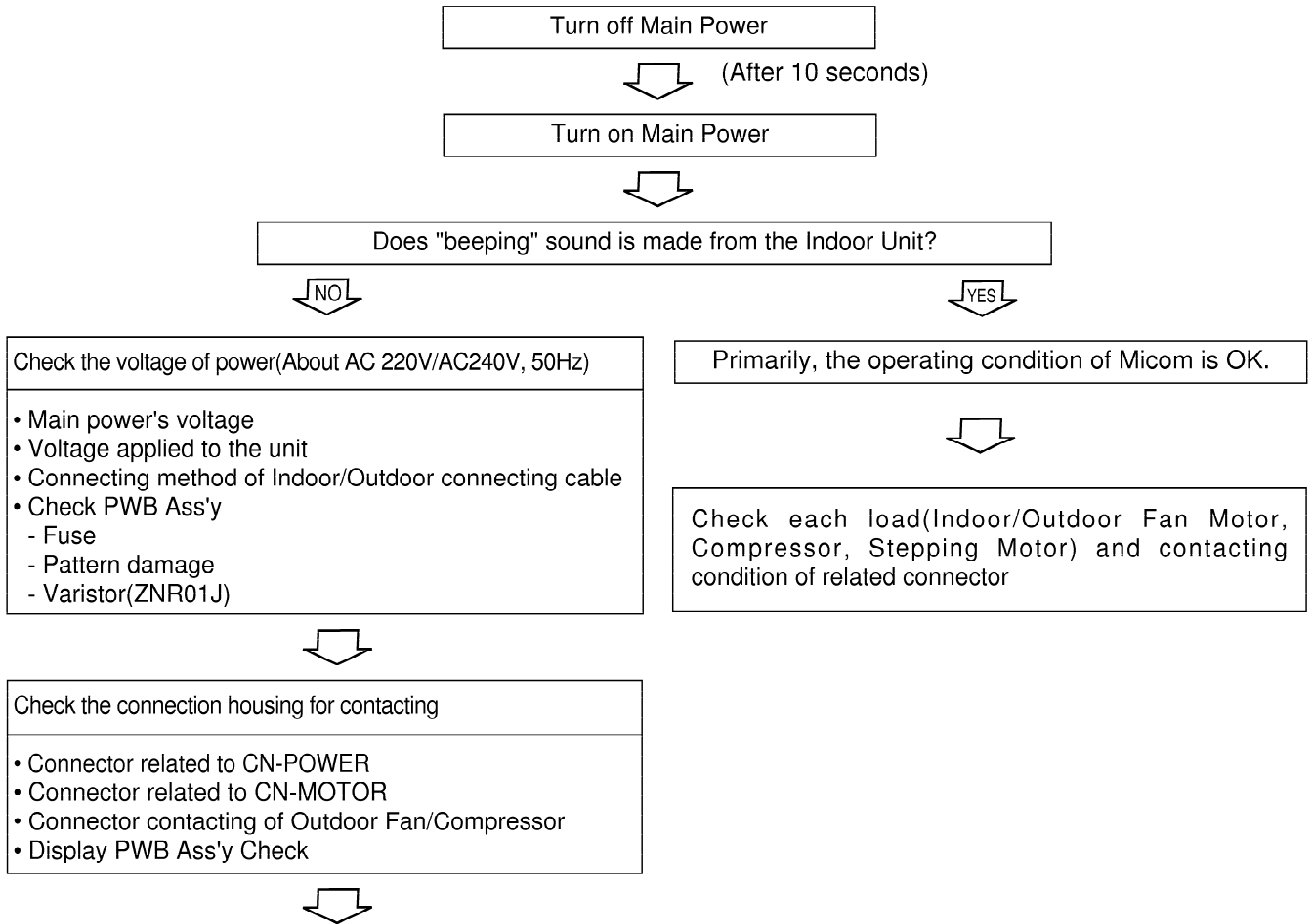

PCB Board Operation Check		
Items	Content	Remedy
<ul style="list-style-type: none"> Power Transformer (Outdoor unit) <ul style="list-style-type: none"> - Input Voltage - Output Voltage 	<ul style="list-style-type: none"> - About AC220V/240V±10% - Check the power voltage - About AC14±3V 	<ul style="list-style-type: none"> • Replace Trans
<ul style="list-style-type: none"> ↓ IC01D(7812) Output (Outdoor unit) 	<ul style="list-style-type: none"> • DC +12V 	<ul style="list-style-type: none"> • Replace IC01D (Outdoor unit)
<ul style="list-style-type: none"> ↓ IC02D(7805) Output (Outdoor unit) IC04D(7805) Output (Indoor unit) 	<ul style="list-style-type: none"> • DC +5V 	<ul style="list-style-type: none"> • Replace IC02D (Outdoor unit) • Replace IC04D(Indoor unit)
<ul style="list-style-type: none"> ↓ IC01A(KIA7036, Reset IC) OSC01B(8MHz) (Indoor unit) IC01A(KIA7036, Reset IC) OSC01B(4MHz) (Outdoor unit) 	<ul style="list-style-type: none"> • Voltage of Micom No. 2, (Indoor unit) (DC +4.5V over) and Soldering condition. No. 5 (Outdoor unit) 	<ul style="list-style-type: none"> • Replace faulty parts

2. The product is not operate with the remote controller.

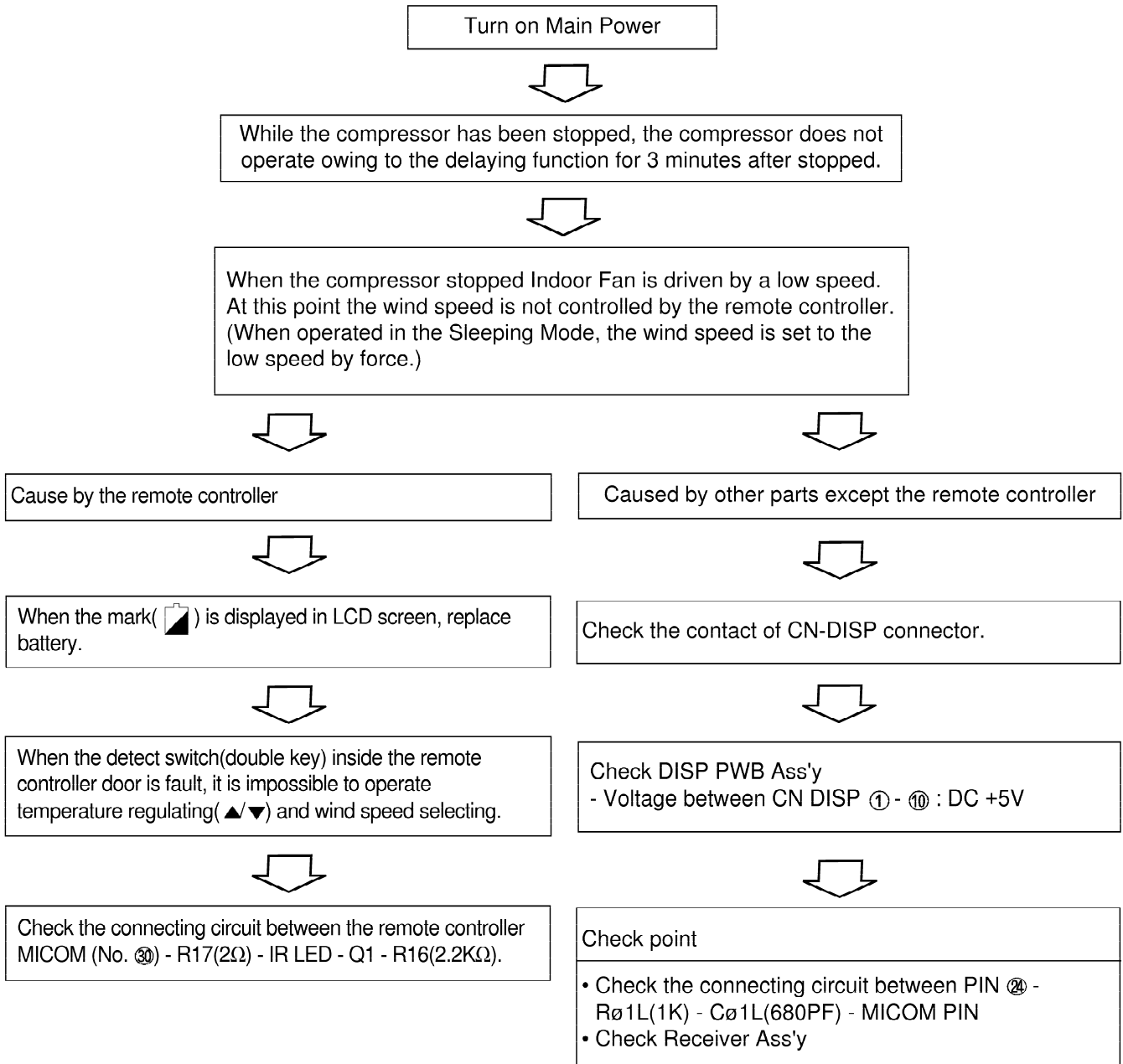

3. Compressor/Outdoor Fan are unable to drive.

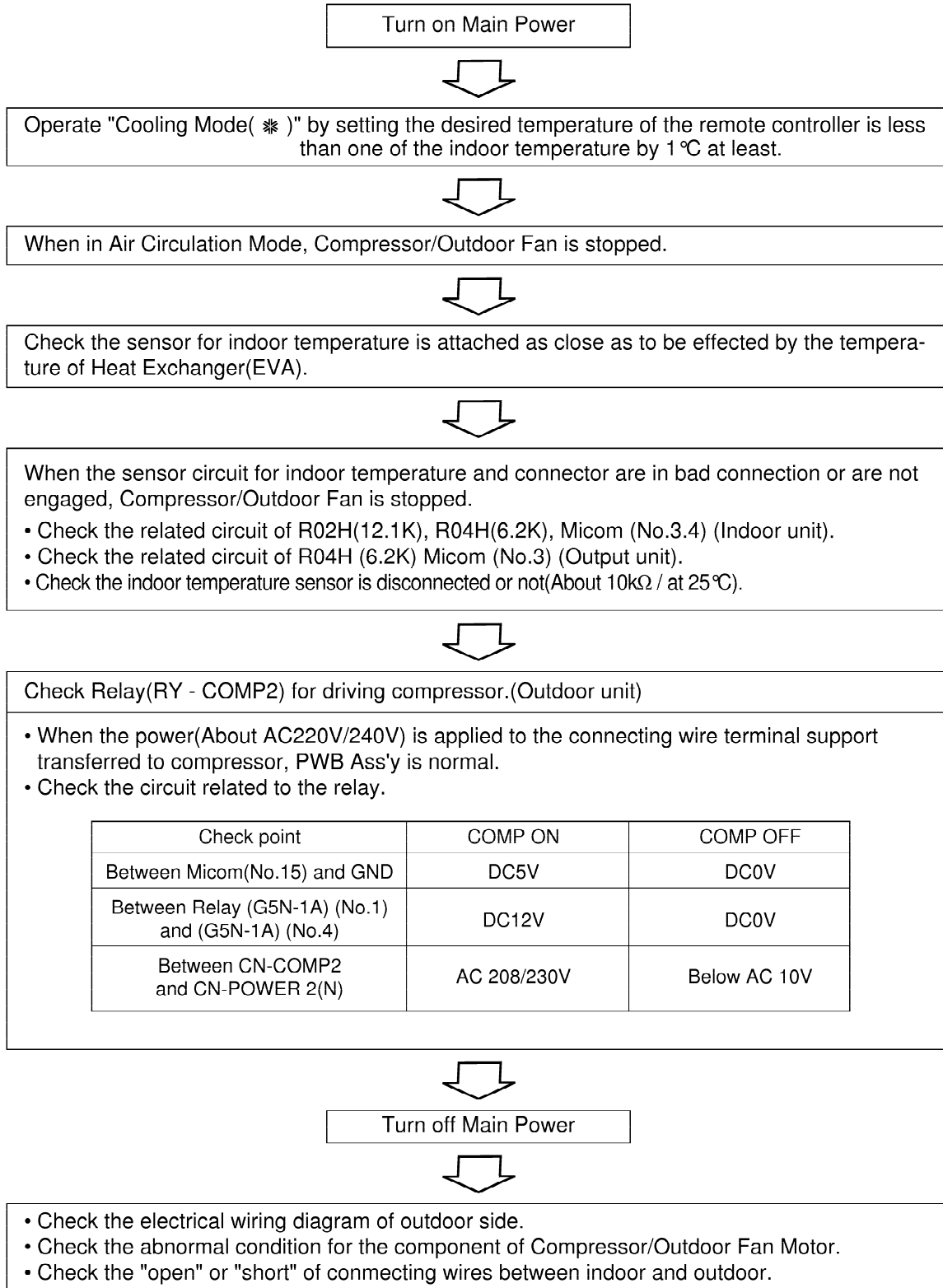

4. When indoor Fan does not operate.

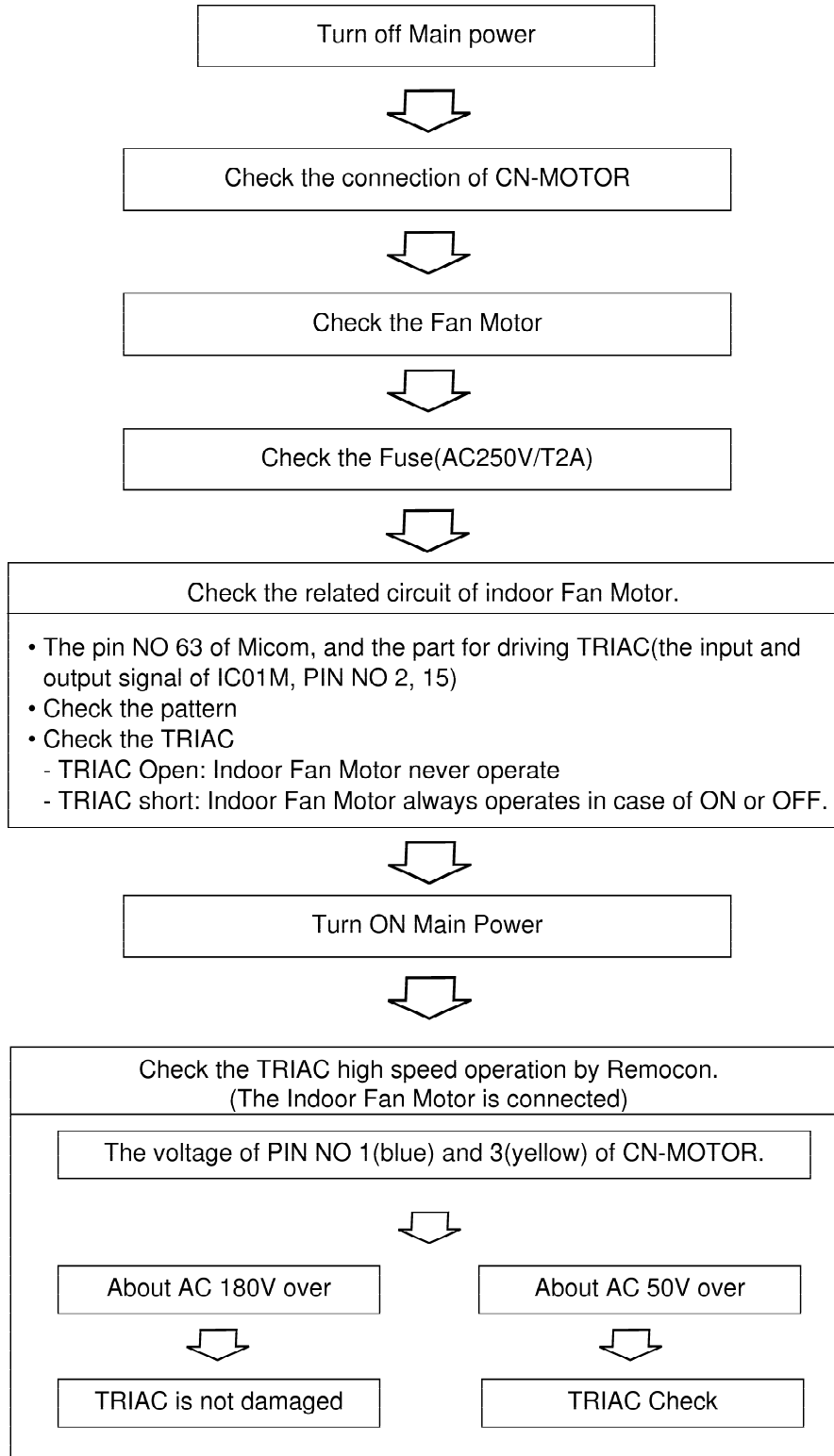

5. When Vertical Louver does not operate.

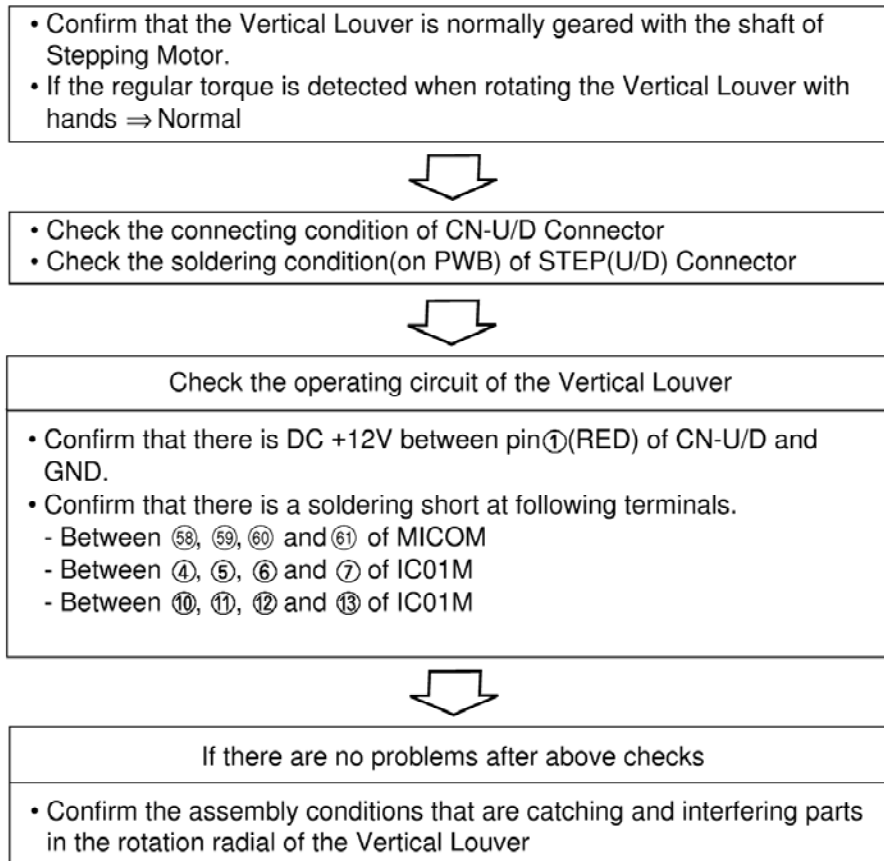

6. When Heating does not operate

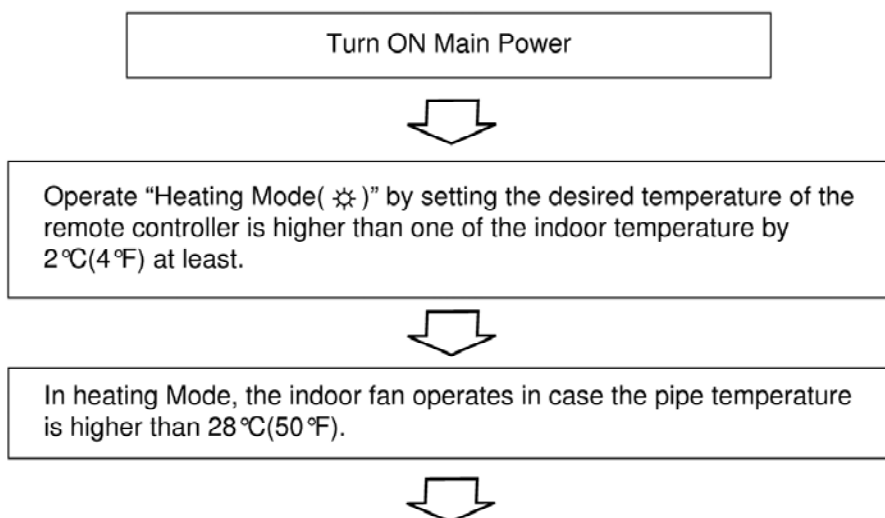



Check the connector of intake and pipe sensor(thermistors)

- Check the related circuit of R02H(12.1K), R04H(6.2K), R03H(1.0K), Micom(No. 3, 4).
- Check the indoor room temperature is disconnected or not (about 10KΩ/at 25°C).
- Check the indoor pipe temperature is disconnected or not (about 5KΩ/at 25°C).



Check the DC voltage on the PWB ASS'Y

- The details of check are as followings

- Comp Relay.

CHECK POINT	COMP. ON	COMP. OFF
Between Micom (No.15) and GND	DC5V	DC0V
Between RY-COMP. (No.1) and (No.4)	About DC12V	DC0V
Between CN-COMP2 and CN-POWER 2(N)	AC 208/230V	Below AC10V

- Outdoor fan Relay

CHECK POINT	COMP. ON	COMP. OFF
Between Micom (No.14) and GND	DC5V	DC0V
Between RY-FAN (No.1) and (No.4)	About DC12V	DC0V
Between CN-FAN and CN-POWER 2(N)	AC 208/230V	Below AC10V

- 4 way Relay

CHECK POINT	COMP. ON	COMP. OFF
Between Micom (No.13) and GND	DC5V	DC0V
Between RY-4WAY (No.1) and (No.4)	About DC12V	DC0V
Between CN-4WAY and CN-POWER 2(N)	AC 208/230V	Below AC10V



Turn off Main Power



- Check the electrical wiring diagram of outdoor side.
- Check the abnormal condition for the component of Compressor/Outdoor Fan Motor, 4 way.
- Check the "open" or "short" of connecting wires between indoor and outdoor.

Electronic Control Device

(1) INDOOR UNIT P.W.B. ASSEMBLY

P/No.: 6871A10153 (PCB ASSEMBLY, MAIN)

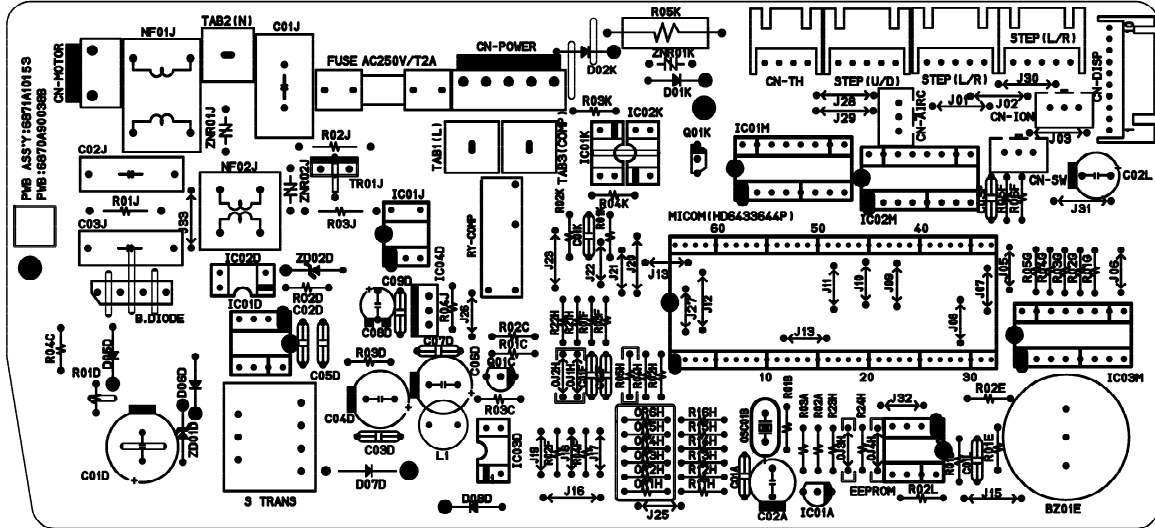

(2) OUTDOOR UNIT P.W.B. ASSEMBLY

TOP VIEW

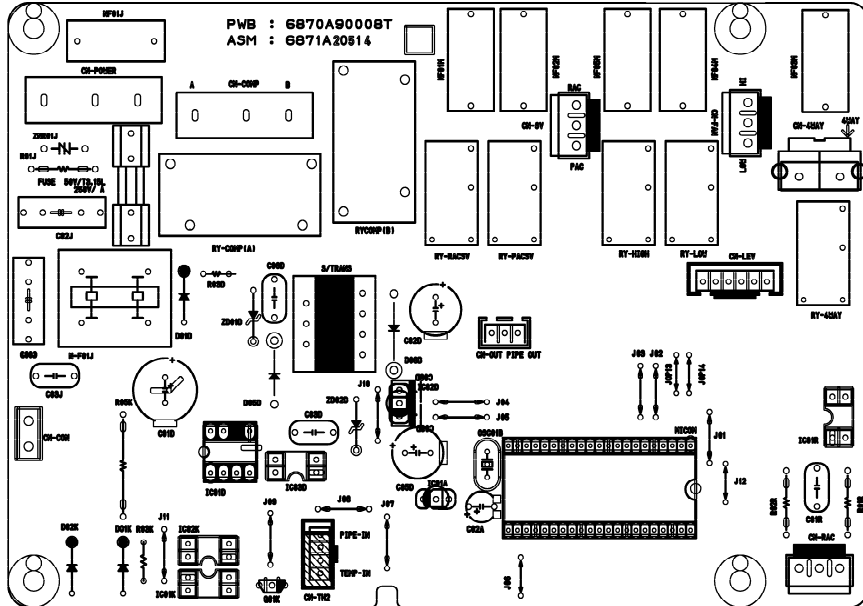

BOTTOM VIEW

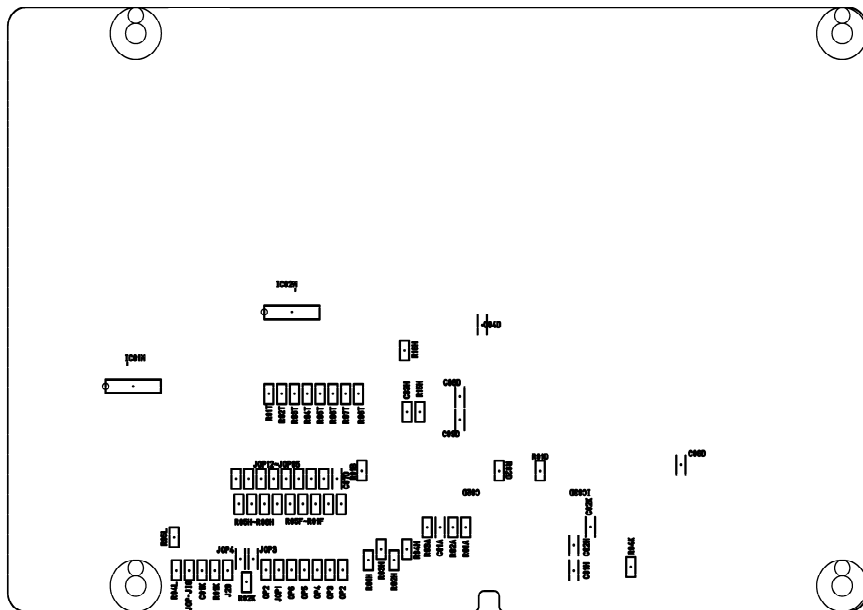

(3) DISPLAY P.W.B. ASM

■ Model: HMC030KD1, HMM030KD1

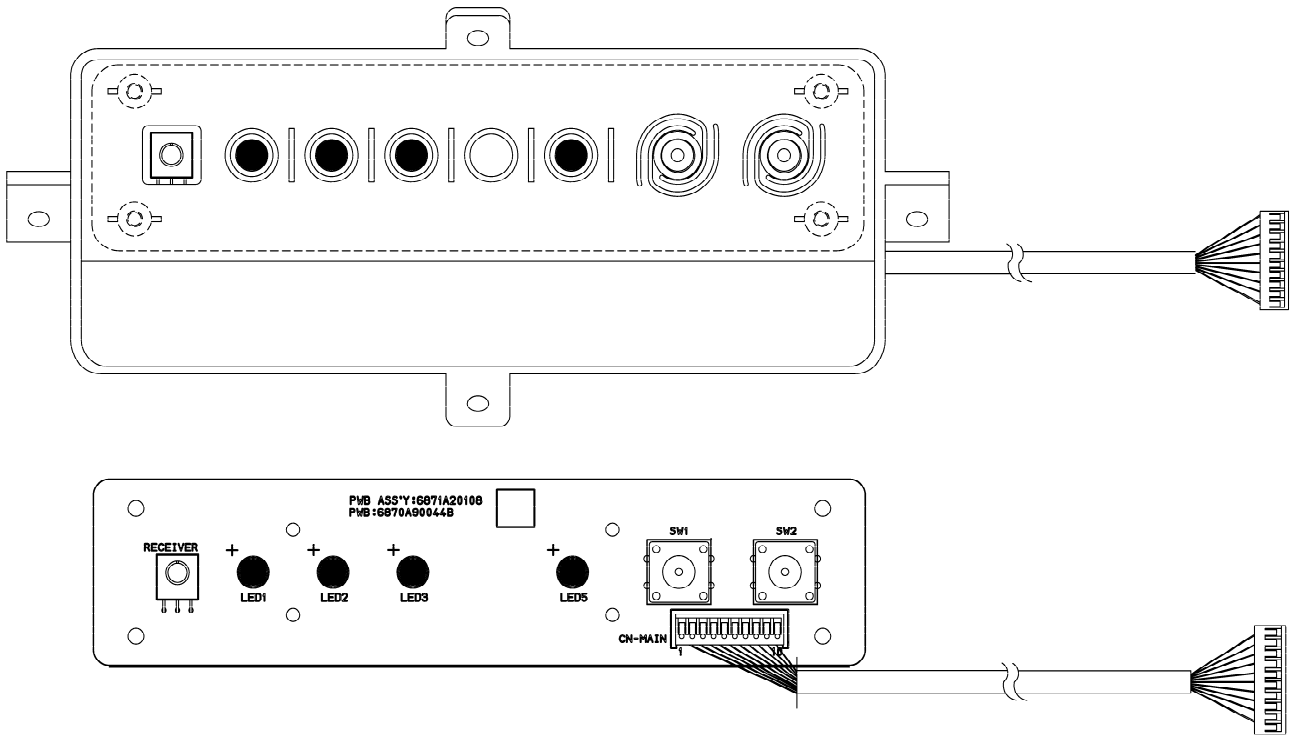

Schematic Diagram

(1) Heat Pump/Cooling Only Series(Indoor Unit)

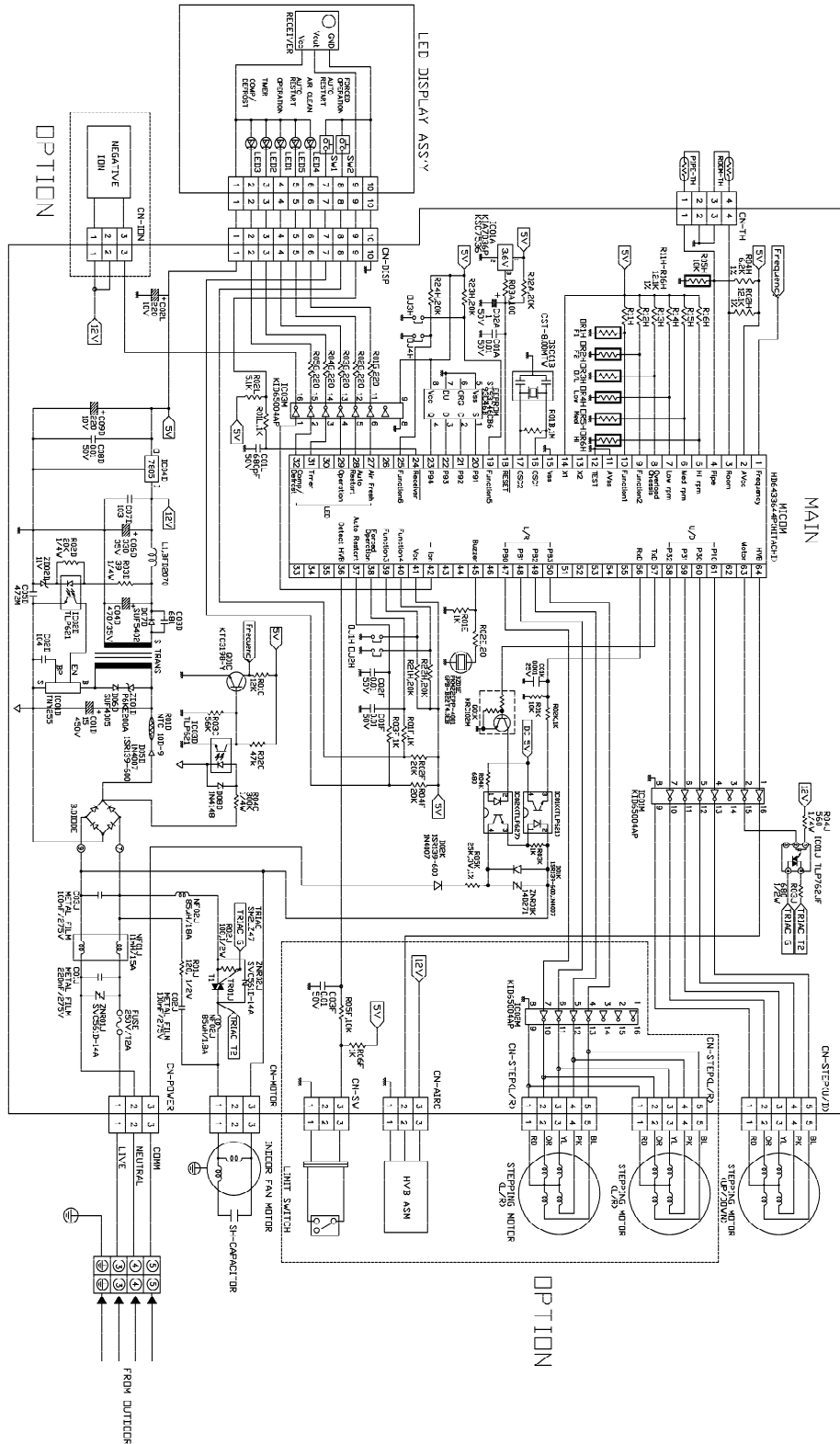

(2) Heat Pump Series (Outdoor Unit)

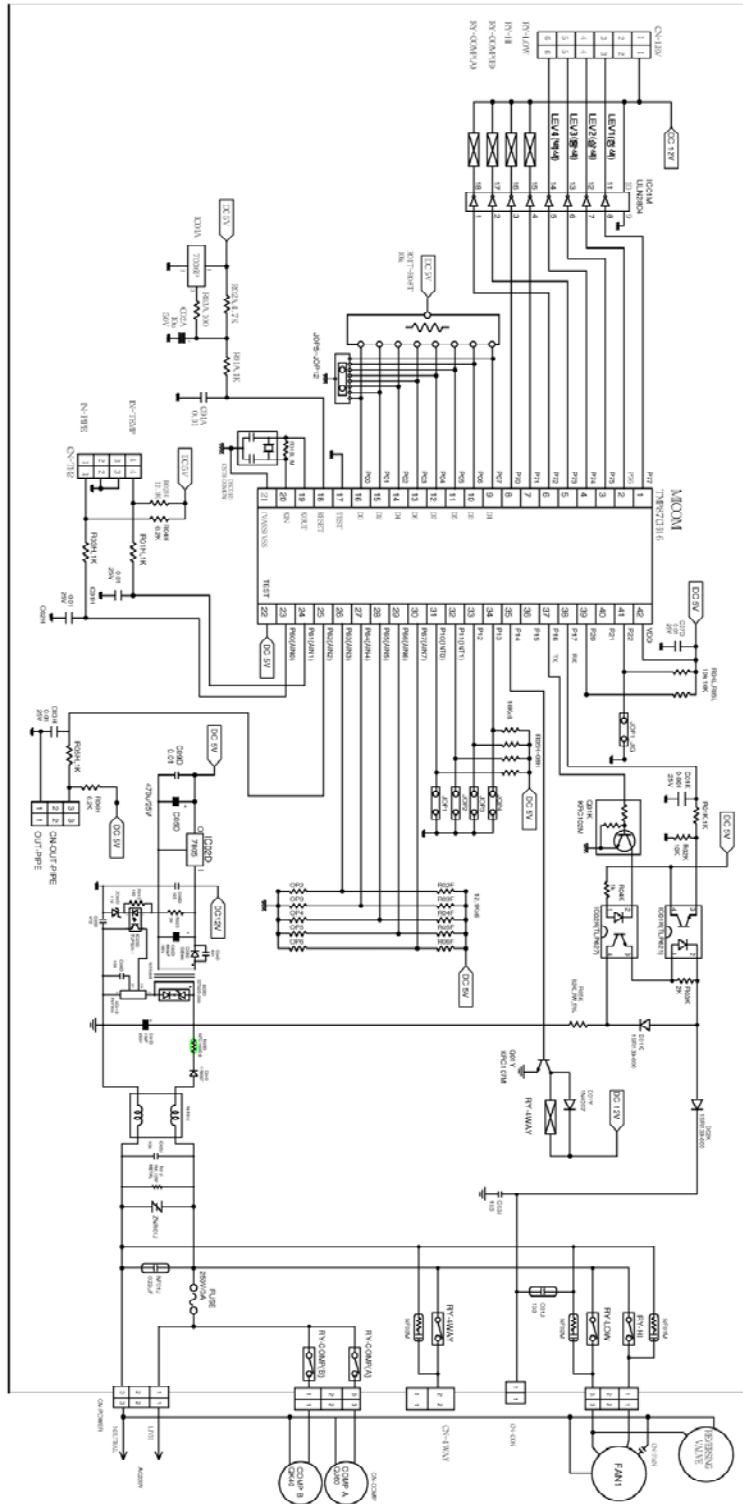

Exploded View and Replacement Parts List

1. Indoor Unit

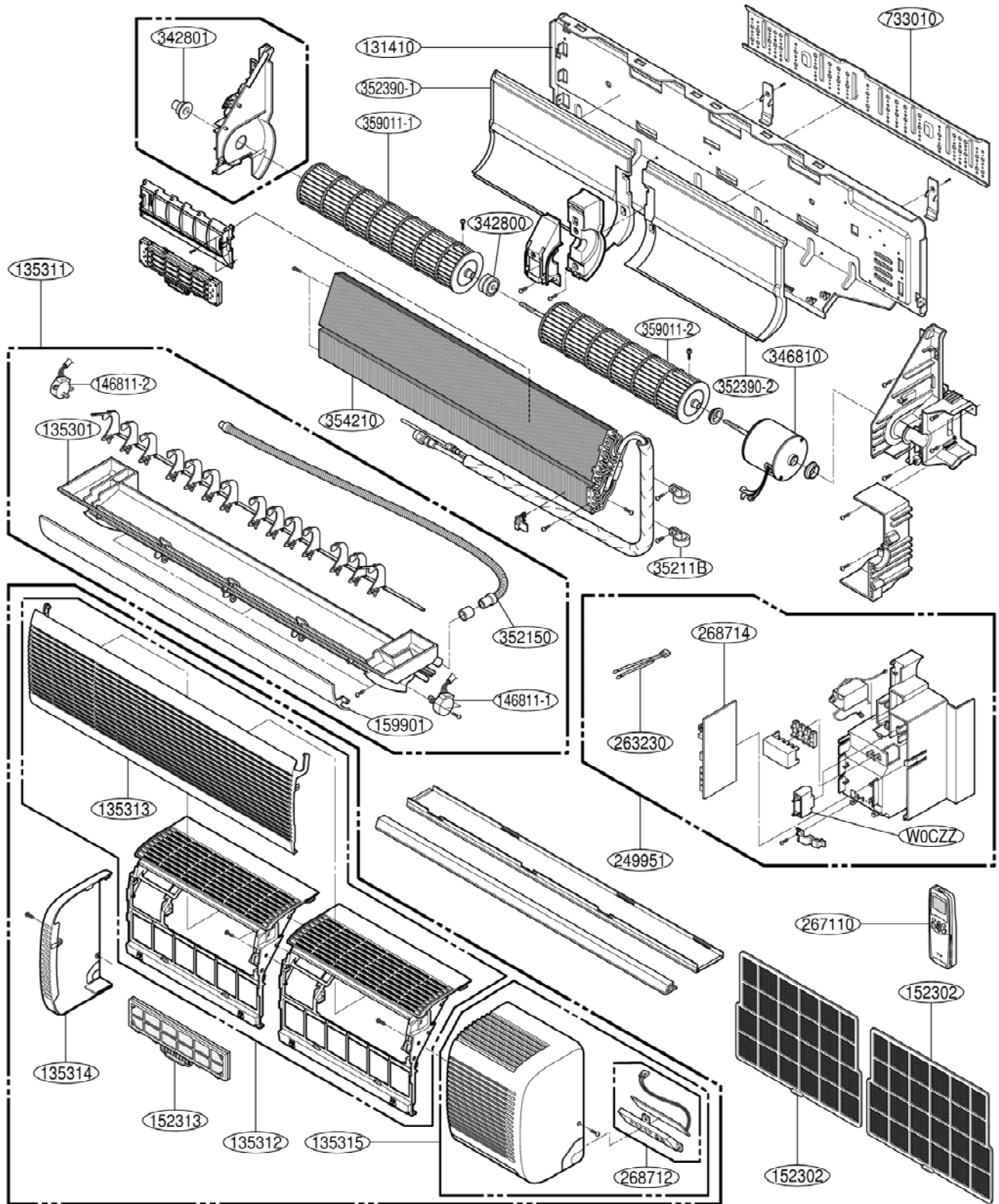

Parts List(Indoor)

LOCATION NO.	DESCRIPTION	PART NO.		REMARKS
		HMC030KD1	HMH030KD1	
131410	CHASSIS ASSEMBLY	3141A10001D	3141A10001D	
135311	GRILLE ASSEMBLY,DISCHARGE(INDOOR)	3531A10056M	3531A10056M	
135312	GRILLE ASSEMBLY,FRONT(INDOOR)	3531A10058M	3531A10058M	
135313	GRILLE ASSEMBLY,INLET	3531A10060F	3531A10060F	
135314	GRILLE,INLET	3530A10042B	3530A10042B	
135315	GRILLE ASSEMBLY,FRONT(INDOOR)	3531A10057V	3531A10057V	
146811-1	MOTOR ASSEMBLY,STEP	4681AR2727B	4681AR2727B	
146811-2	MOTOR ASSEMBLY,STEP	-	-	
147582	LOUVER,VERTICAL	4758A30018A	4758A30018A	
152302	FILTER(MECH),A/C	5230A10001A	5230A10001A	
152313	FILTER ASSEMBLY,DEODORIZER	5231A20032F	5231A20032F	
159901	VANE,HORIZONTAL	5990A20003B	5990A20003B	
249951	CONTROL BOX ASSEMBLY,INDOOR	4995A20337H	4995A20337H	
263230	THERMISTOR ASSEMBLY	6323A20002C	6323A20002C	
267110	REMOTE CONTROLLER ASSEMBLY	6711A20025M	6711A20025M	
268712	PWB(PCB) ASSY,DISPLAY	6871A20108A	6871A20108A	
268714	PWB(PCB) ASSEMBLY,MAIN	6871A10153B	6871A10153B	
342800	BEARING	4280A20003A	4280A20003A	
342801	BEARING	4280A20001A	4280A20001A	
346810	MOTOR ASSEMBLY,INDOOR	4681AP2632H	4681AP2632H	
35211B	TUBE ASSY,TUBING	5211A20200A	5211A20200A	
352150	HOSE ASSY,DRAIN	5251AR1222P	5251AR1222P	
352390-1	AIR GUIDE ASSEMBLY	5239A10001A	5239A10001A	
352390-2	AIR GUIDE ASSEMBLY	5239A10001B	5239A10001B	
354210	EVAPORATOR ASSEMBLY,FIRST	5421A20058A	5421A20057A	
359011-1	FAN ASSY,CROSS FLOW	5901AR2441G	5901AR2441G	
359011-2	FAN ASSY,CROSS FLOW	5901AR2441F	5901AR2441F	
733010	PLATE ASSY,INSTALL	3301A10001A	3301A10001A	
W0CZZ	CAPACITOR,DRAWING	3H01487G	3H01487G	

NOTE) *Please ensure GCSC since these parts may be changed depending upon the buyer's request.
(GCSC WEBSITE <http://biz.LGservice.com>)

2. Outdoor Unit

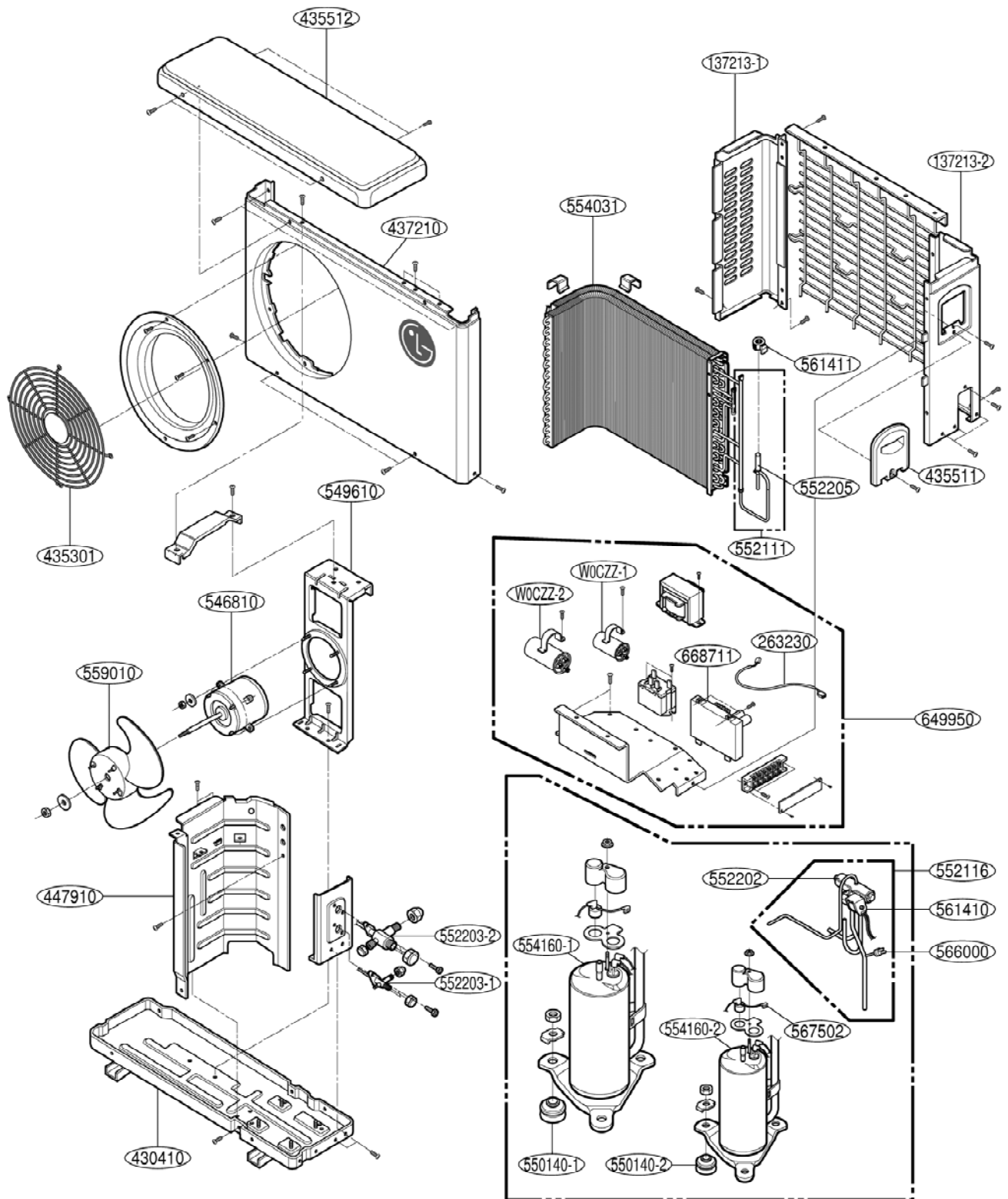

Parts List(Outdoor)

LOCATION NO.	DESCRIPTION	PART NO.		REMARKS
		HMC030KD1	HMH030KD1	
137213-1	PANEL ASSEMBLY,SIDE	1A00202F	1A00202F	
137213-2	PANEL ASSY,SIDE	1A00202C	1A00202C	
263230	THERMISTOR ASSEMBLY	6323A20002L	6323A20002L	
430410	BASE ASSY,OUTDOOR	3041AP2741L	3041AP2741L	
435301	GRILLE,DISCHARGE	3530A20007J	3530A20007J	
435511	COVER ASSY,CONTROL(OUTDOOR)	3551AR7184T	3551AR7184T	
435512	COVER ASSEMBLY, TOP(OUTDOOR)	3H03266H	3H03266H	
437210	PANEL ASSY,FRONT SUB	1A00197C	1A00197C	
447910	BARRIER ASSEMBLY,OUTDOOR	4791A30004G	4791A30004G	
546810	MOTOR ASSEMBLY,AC	4681A20008E	4681A20008E	
549610	MOUNT ASSY,MOTOR(OUTDOOR)	2A01035T	2A01035T	
550140-1	ISOLATOR,COMP	4H00982E	4H00982E	
550140-2	ISOLATOR,COMP	4H00637A	4H00637A	
552111	TUBE ASSEMBLY,CAPILLARY	5211A20034X	5211A20034X	
552116	TUBE ASSEMBLY,REVERSING	-	5211A20057B	
552201	VALVE,CHECK	3A01020H	3A01020H	
552202	VALVE,REVERSING	-	3A02027J	
552203-1	VALVE,SERVICE	2A00393H	2A00393H	
552203-2	VALVE,SERVICE	2A00392N	2A00392N	
552205	VALVE, EXPANSION BODY	5220A90001B	5220A90001B	
554031	CONDENSER ASSEMBLY,BENT	6140AP2096A	6140AP2096Q	
554160-1	COMPRESSOR SET	2520UKVK2BA	2520UKVK2BA	
554160-2	COMPRESSOR SET	2520UHAK2AA	2520UHAK2AA	
559010	FAN ASSEMBLY,PROPELLER	1A00195G	1A00195G	
561410	COIL ASSEMBLY,REVERSING VALVE	-	6141AR3733R	
561411	COIL ASSEMBLY, EXPANSION	6140A30001L	6140A30001L	
566000	SWITCH,PRESSURE	-	3A02524A	
567502	O.L.P	6750U-L063A	6750U-L063A	
649950	CONTROL BOX ASSEMBLY,OUTDOOR	4995A20383D	4995A20383C	
668711	PWB(PCB) ASSEMBLY,MAIN(OUTDOOR)	6871A20514A	6871A20514B	
W0CZZ	CAPACITOR,DRAWING	6120AR2194F	6120AR2194F	
W0CZZ	CAPACITOR,DRAWING	2A00986Y	2A00986Y	

