

Installation

(1) Installation of Indoor, Outdoor unit

1) Selection of the best location

1. Indoor unit

- There should not be any heat source or steam near the unit.
- There should not be any obstacles to prevent the air circulation.
- A place where air circulation in the room will be good.
- A place where drainage can be easily obtained.
- A place where noise prevention is taken into consideration.
- Do not install the unit near the door way.
- Ensure the spaces indicated by arrows from the wall, ceiling, fence, or other obstacles.

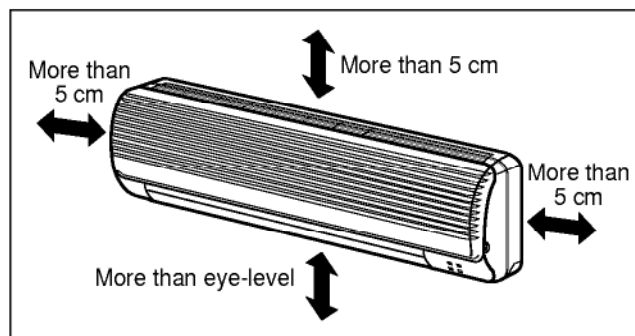
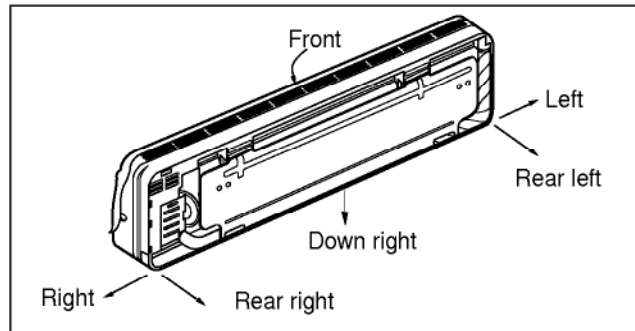

2. Outdoor unit

- If an awning is built over the unit to prevent direct sunlight or rain exposure, be careful that heat radiation from the condenser is not restricted.
- There should not be any animals or plants which could be affected by hot air discharged.
- Ensure the spaces indicated by arrows from the wall, ceiling, fence, or other obstacles.

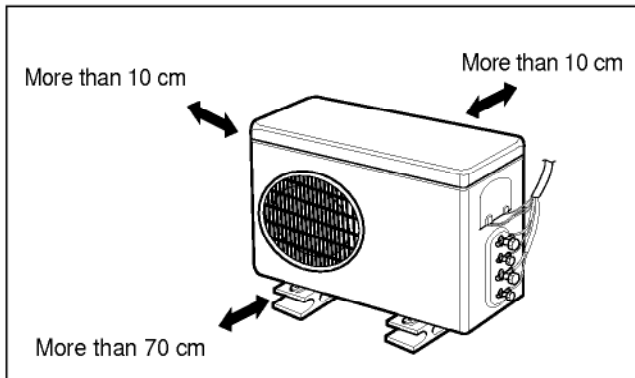

3. Piping length and the elevation

Pipe Size		Max. piping length A (m)	Max. Elevation B (m)
GAS	LIQUID		
1/2"(3/8")	1/4"	10~15	5~7

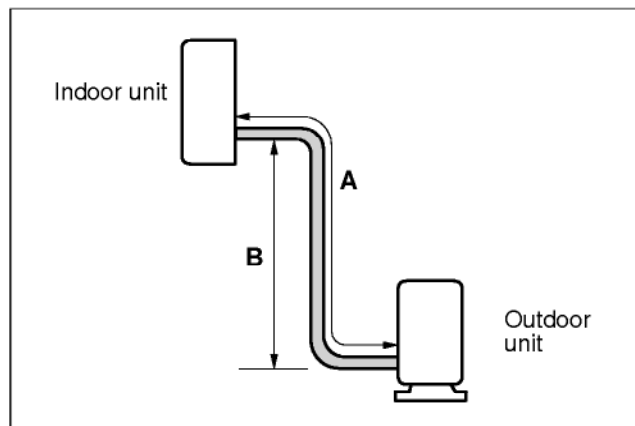

2) Indoor Unit Installation

The mounting wall should be strong and solid enough to protect it from the vibration.

1. Mount the installation plate on the wall with four Type "A" screws.

(If mounting the unit on the concrete wall, consider using anchor bolts.)

- Always mount the Installation plate horizontally by aligning the marking-off line by means of the thread and a level.

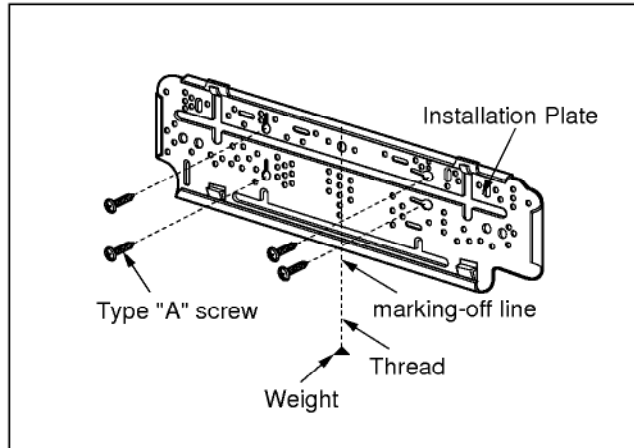

2. Drill the piping hole with 70mm dia. holecore drill.

- Line according to the arrows marked on lower left and the right side of the Installation Plate. The meeting point of the extended line is the center of the hole.
- Drill the piping hole at either the right or the left and the hole should be slightly slant to the outdoor side.

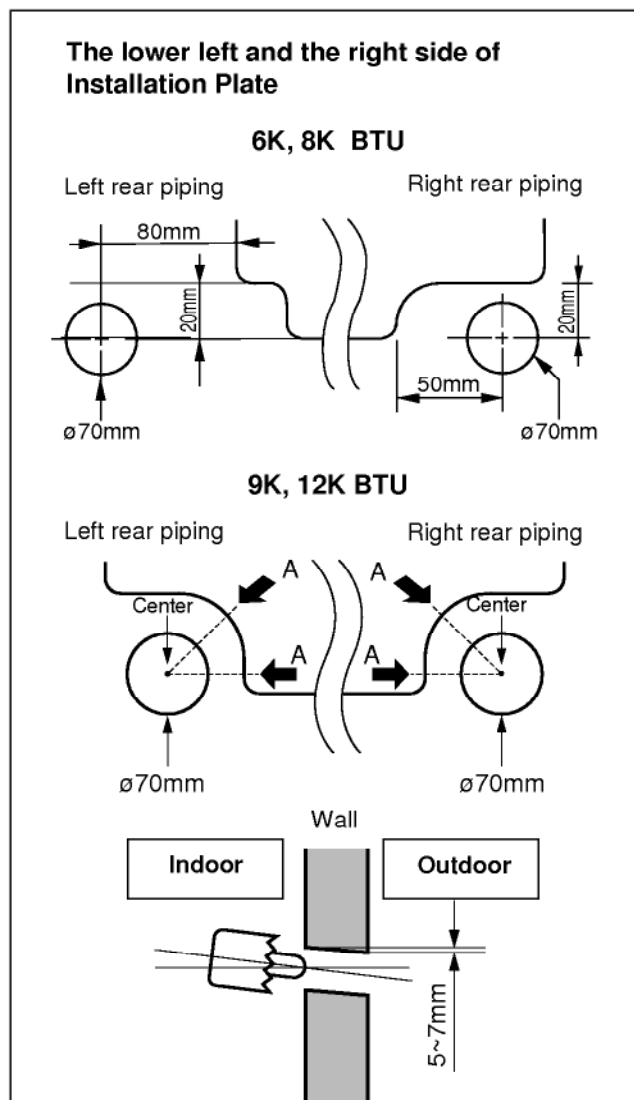

(2) Piping and Drainage of Indoor Unit

1) Preparation of pipings

1. Cut the pipes and the cable.

- Use the accessory piping kit or the pipes purchased locally.
- Measure the distance between the indoor and the outdoor unit.
- Cut the pipes a little longer than the measured distance.
- Cut the cable 1.5m longer than the length of the pipe.

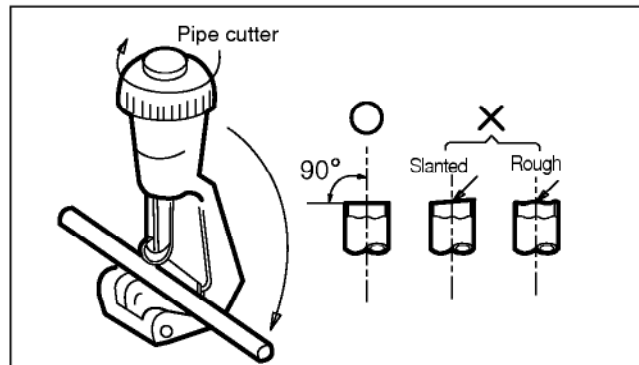

2. Remove burrs.

- Remove burrs from cut edges of pipes.
- Turn the pipe end toward down to avoid the metal powder entering the pipe.

Caution:

If burrs are not removed, they may cause a gas leakage.

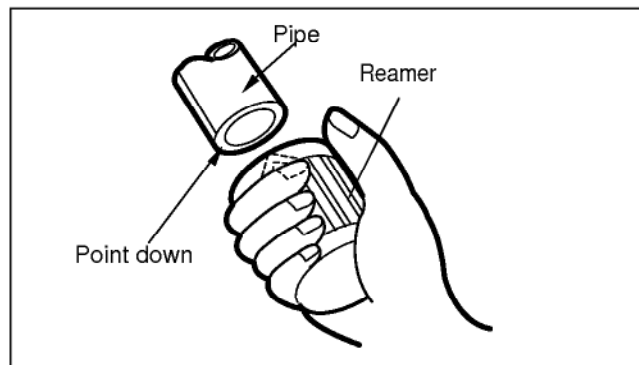

3. Flaring the pipes.

- Insert the flare nuts, mounted on the connection ports of both indoor and outdoor unit, onto the copper pipes. Some refrigerant gas may leak, when the flare nuts are removed from the indoor unit, as some gas is charged to prevent the inside of the pipe from rusting.
- Fit the copper pipe end into the Bar of flare tool about 0~0.5mm higher. (See illustration)
- Flare the pipe ends.

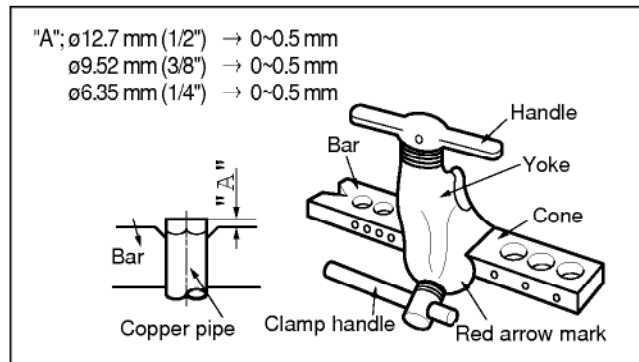

4. Tape the flaring portion to protect it from the dust or damages.

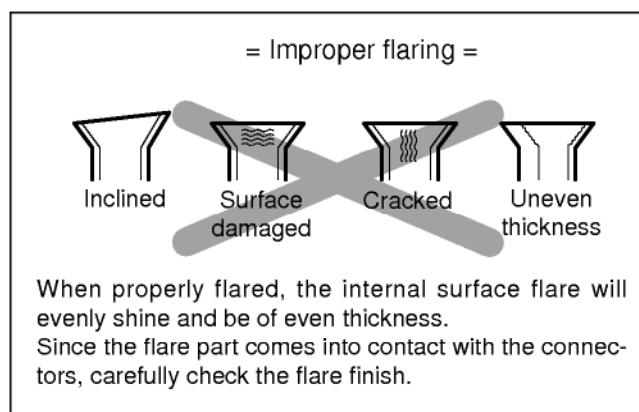

2) Connection of Pippings (6K, 8K BTU)

1. Remove the installation plate

- Pull the two 'Δ' marked portion of bottom of the chassis and pull the installation plate out of chassis.

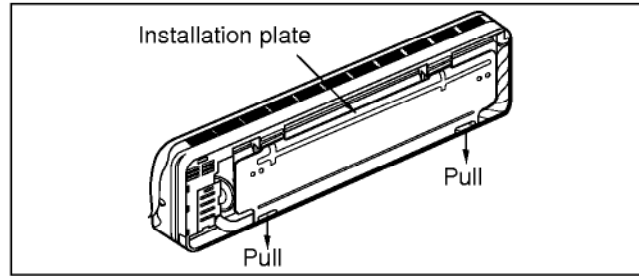

2. Route the drain hose and the indoor tubing.

For right rear piping

3. Insert the pippings, the connecting cables and the drain pipe through the piping hole on the wall.

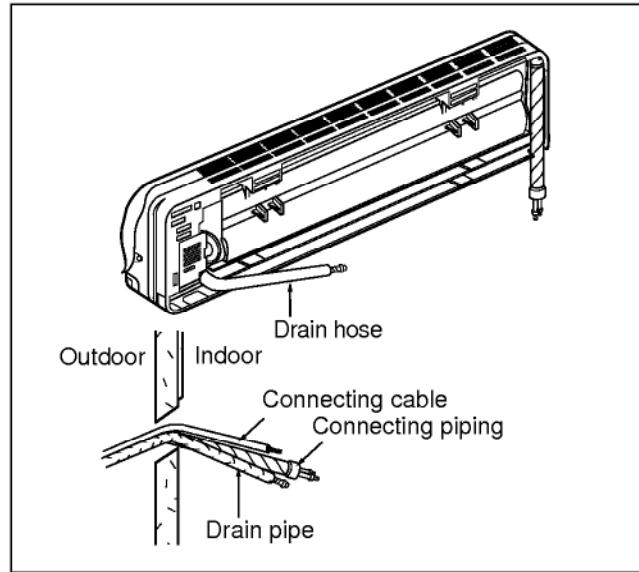

4. Connect the pippings and the indoor tubing, and drain hose and drain pipe.

- Don't connect the cable to the indoor unit.

Pipe Size	Torque
Liquid Side (1/4")	1.8kg·m
Gas Side (3/8")	4.2kg·m

- Wrap the insulation material around the connecting portion.

- Glue up the connection portion of drain hose and drain pipe.

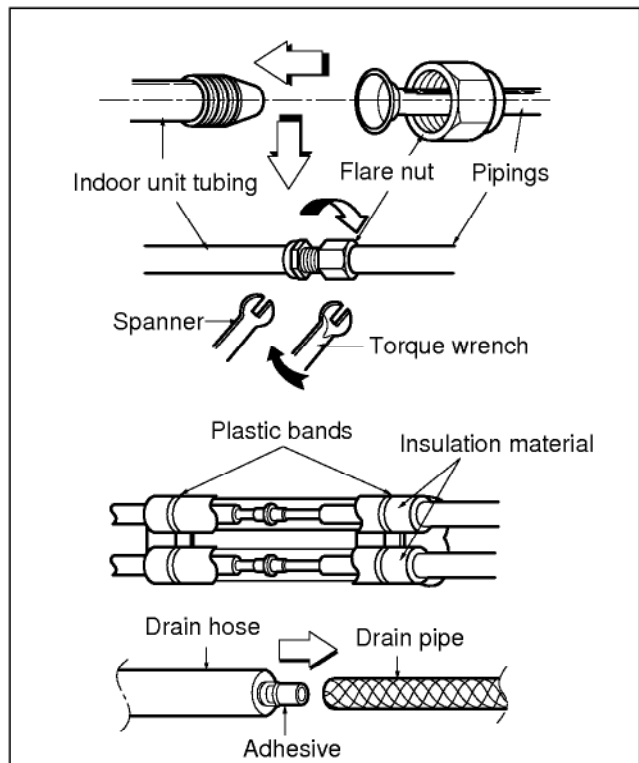

5. Bend the tubing as shown in the figure and bind the pipings, the connecting cables and the drain hose altogether.

- Make a small loop for easy connection later.

6. Wrap the tubing, the drain hose and the connecting cable.

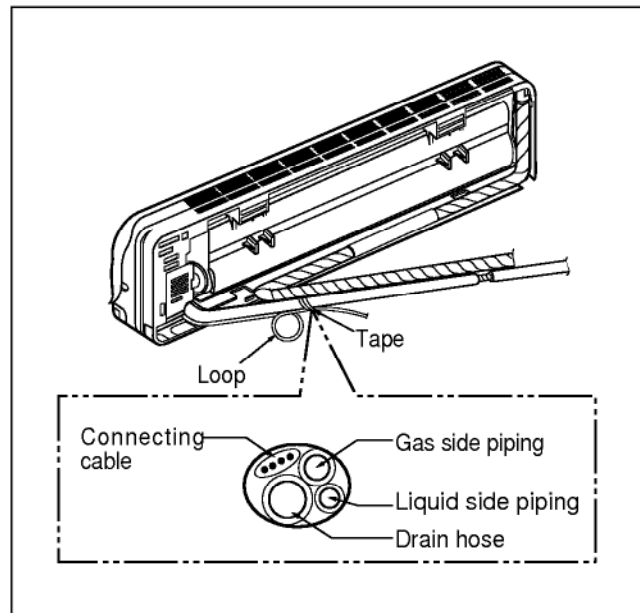

7. Indoor unit installation

- Hook the indoor unit onto the upper portion of the installation plate. (Engage the two hooks of the rear top of the indoor unit with the upper edge of the installation plate.)
Insure the hooks are properly seated on the installation plate by moving it in left and right.

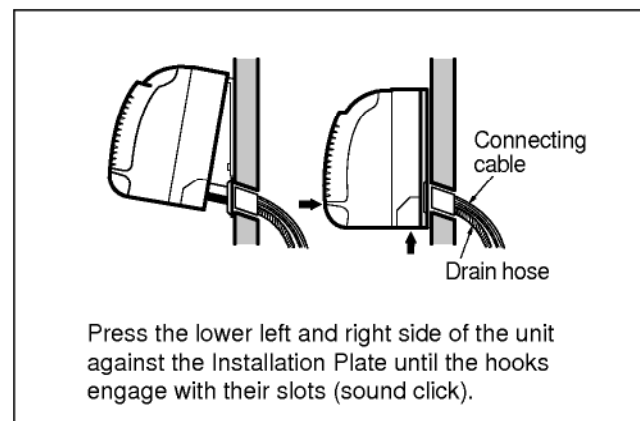

CAUTION: Take care to arrange the pipings, drain hose and cables as the picture on page 33 for inserting it into the indoor unit and mount the indoor unit on the installation plate.

3) Connection of Pipings

1. Remove the indoor tubing with Drain hose to the hole.
 - Remove tubing holder and pull the tubing out of the chassis.
2. Refix the tubing holder into original position.

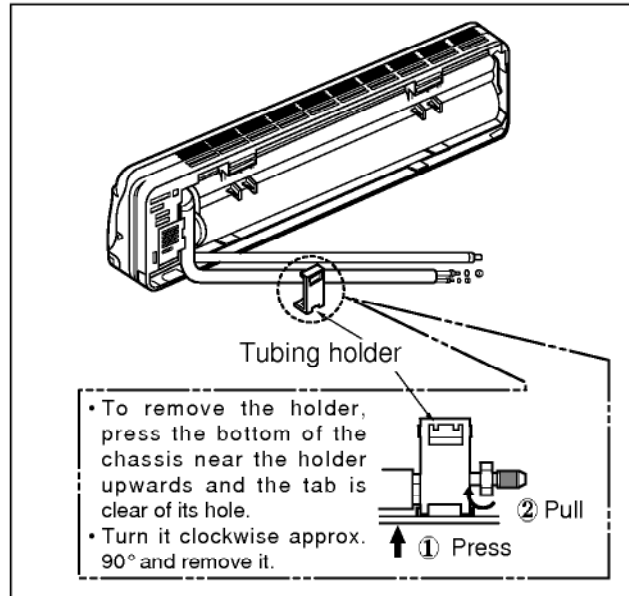

For right rear piping

3. Route the tubing and the drain hose straight backwards(see figure).
4. Insert the connecting cable into the indoor unit through the piping hole.
 - Do not connect the cable to the indoor unit.
 - Make a small loop with the cable for easy connection later.

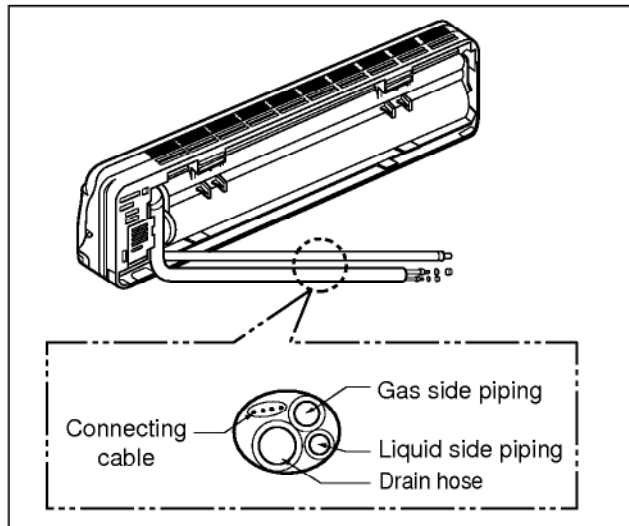

5. Tape the tubing, drain hose and the connecting cable. Be sure that drain hose locates at the lowest side of the bundle. Locating at the upper side can be a reason that drain water overflows drain pan inside the unit.

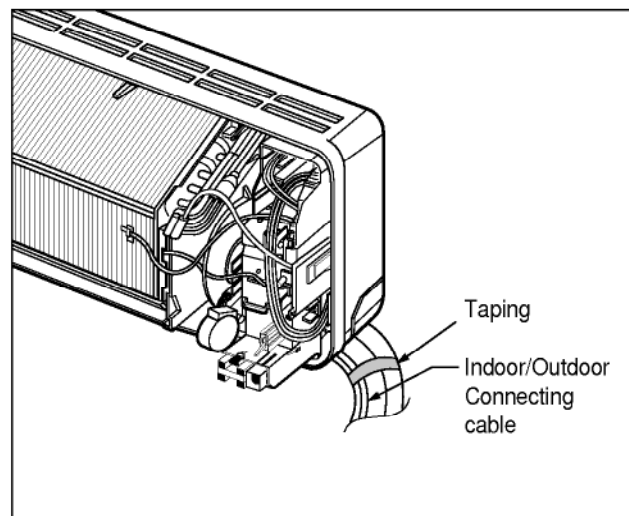

6. Indoor unit installation.

- Hook the indoor unit onto the upper position of the installation plate. (Engage the two hooks of the rear top of the indoor unit with the upper edge of the installation plate.)
Ensure the hooks are properly seated on the installation plate by moving it in left and right.

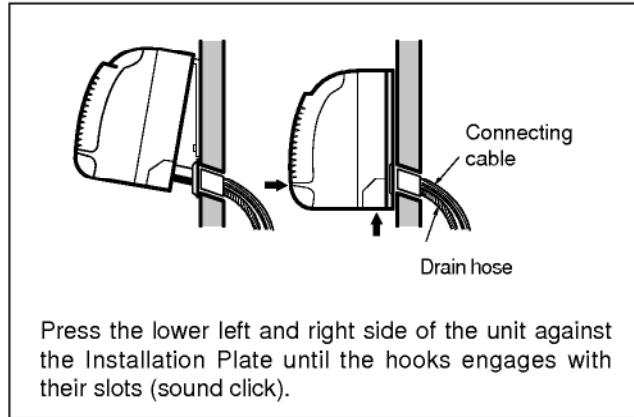

7. Connecting the pipings to the indoor unit.

- Align the center of the pipings and sufficiently tighten the flare nut with fingers.
- Finally, tighten the flare nut with torque wrench until the wrench clicks.
Wrench tightening the flare nut with forque wrench, ensure the direction for tightening follows the arrows on the wrench.

Pipe Size	Torque
Liquid Side (1/4")	1.8kg .m
Gas Side (3/8")	4.2kg .m
Gas Side (1/2")	5.5kg .m

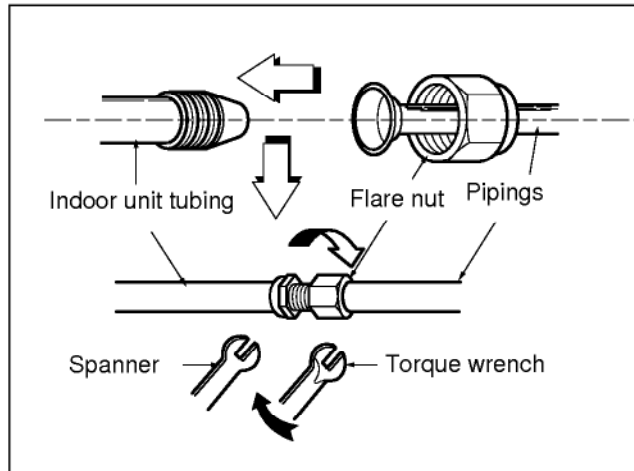

8. Wrap the insulation material around the connecting portion.

CAUTION: Take care to arrange the pipings, drain hose and cables as the right upper picture for inserting it into the indoor unit and refixing the tubing holder easily.

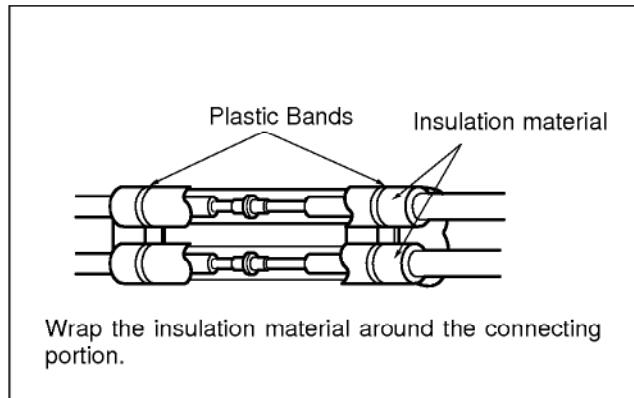

For left rear pipings

3. Route the indoor tubing with the drain hose to the piping hole as desired position.

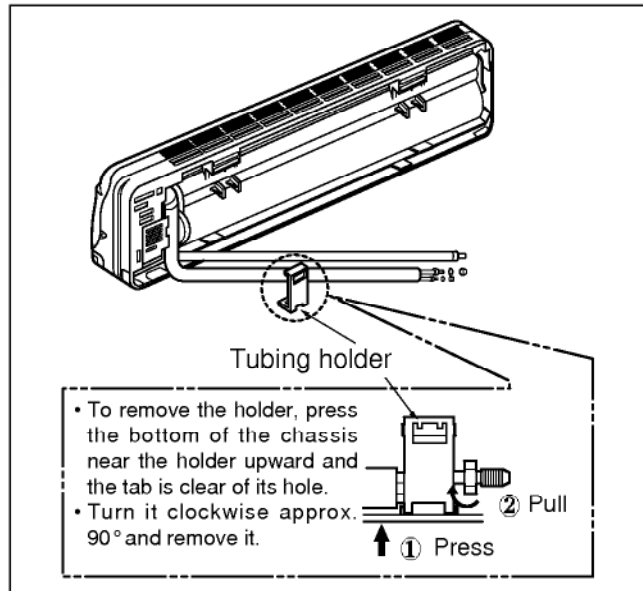

4. Insert the pipings and the connecting cable into the piping hole.

5. Insert the connecting cable into the indoor unit.

- Don't connect the cable to the indoor unit.
- Make a small loop with the cable for easy connection later.

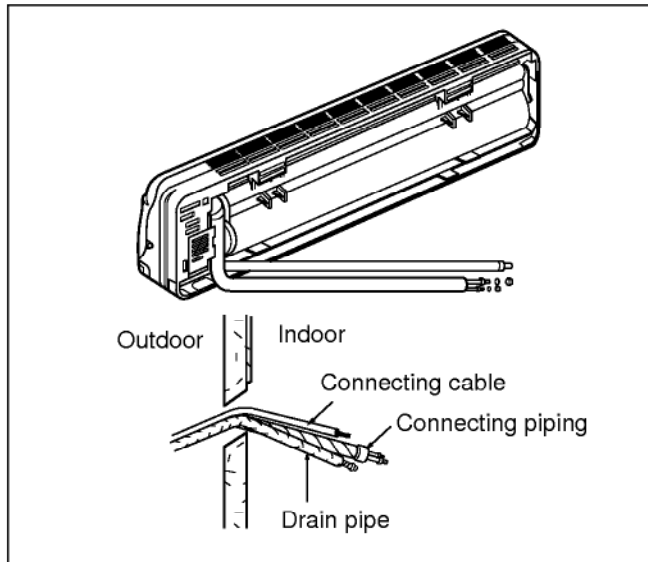

6. Tape the tubing, drain hose and the connecting cable.

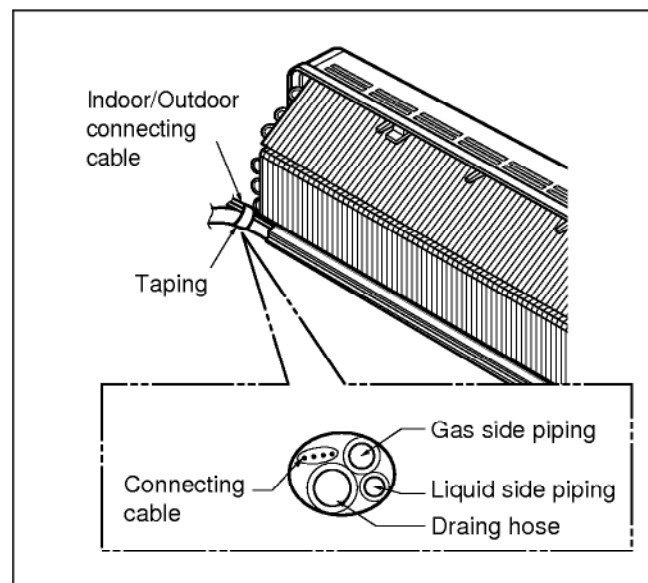

7. Indoor unit installation

- Hook the indoor unit onto the upper position of installation plate. (Engage the two hooks of the rear top of the indoor unit with the upper edge of the installation plate.)
Ensure the hooks are properly seated on the installation plate by moving it in left and right.

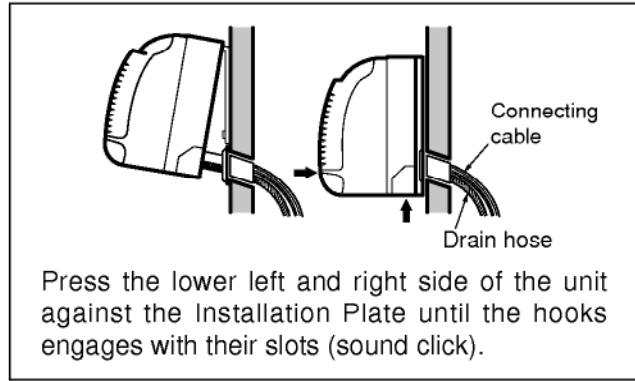

8. Connecting the pipings to the indoor unit

- Align the center of the pipings and sufficiently tighten the flare nut with fingers.
- Finally, tighten the flare nut with torque wrench until the wrench clicks.
Wrench tightening the flare nut with torque wrench, ensure the direction for tightening follows the arrows on the wrench.

Pipe Size	Torque
Liquid Side (1/4")	1.8kg .m
Gas Side (3/8")	4.2kg .m
Gas Side (1/2")	5.5kg .m

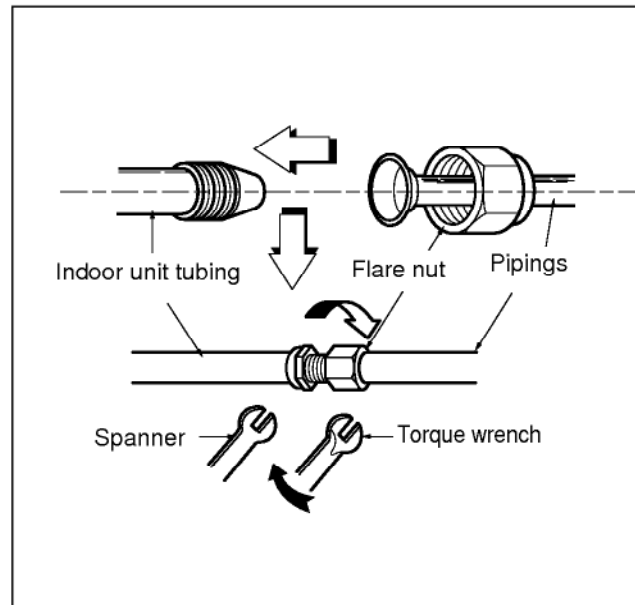

9. Wrap the insulation material around the connecting portion.

CAUTION: Take care to arrange the pipings, drain hose and cables as the right upper picture for inserting it into the indoor unit and refixing the tubing holder easily.

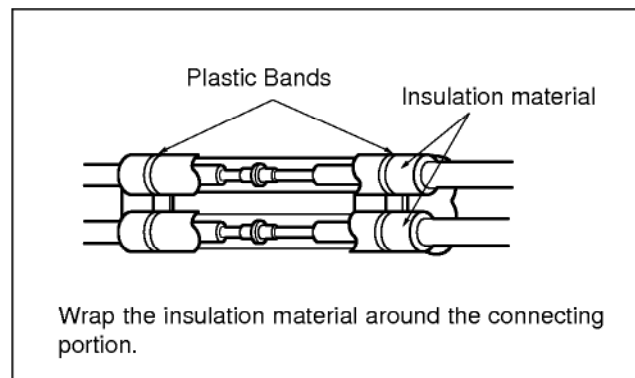

10. Set the pipings and the connecting cable to the back of the chassis with the tubing holder.

- Hook the edge of tubing holder to tap on chassis and push the bottom of tubing holder to be engaged in the bottom of chassis.

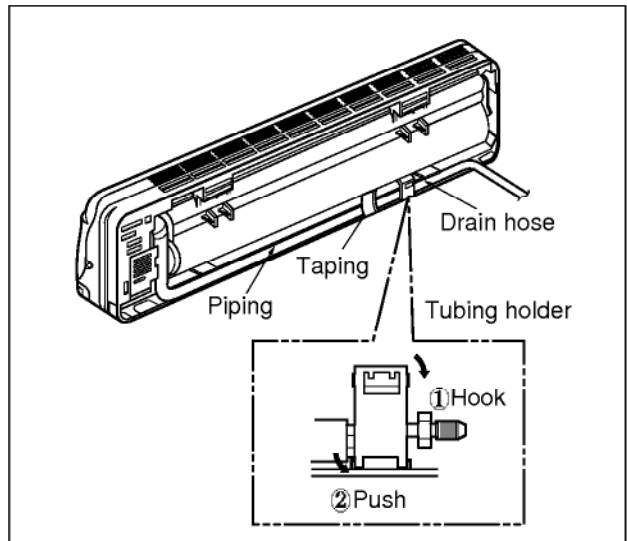
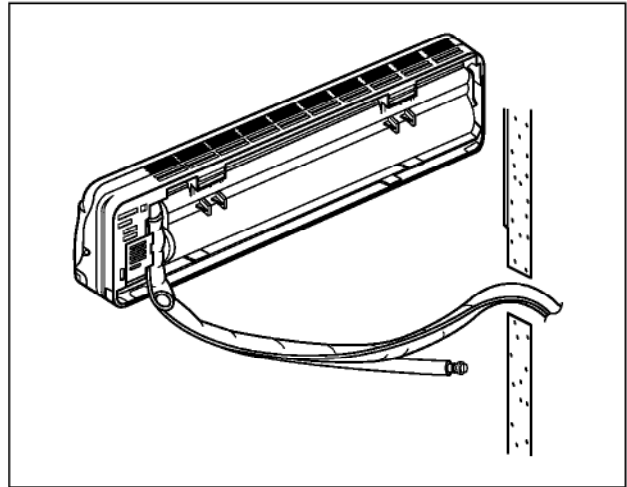

11. Indoor unit installation.

- Hook the indoor unit onto the upper portion of installation plate. (Engage the two hooks of the rear top of the indoor unit with the upper edge of the installation plate.)
Ensure the hooks are properly seated on the installation plate by moving it in left and right.

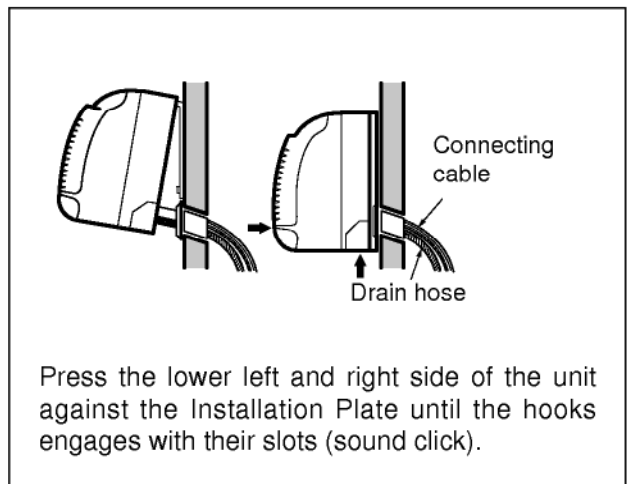

(3) Connecting Pipings and the cable to Outdoor unit

1) Connecting the pipings to the Outdoor unit

1. Align the center of the pipings and sufficiently tighten the flare nut with fingers.
2. Finally, tighten the flare nut with torque wrench until the wrench clicks.
 - When tightening the flare nut with torque wrench, ensure the direction for tightening follows the arrow on the wrench.

Pipe Size	Torque
Liquid Side (1/4")	1.8kg .m
Gas Side (3/8")	4.2kg .m
Gas Side (1/2")	5.5kg .m

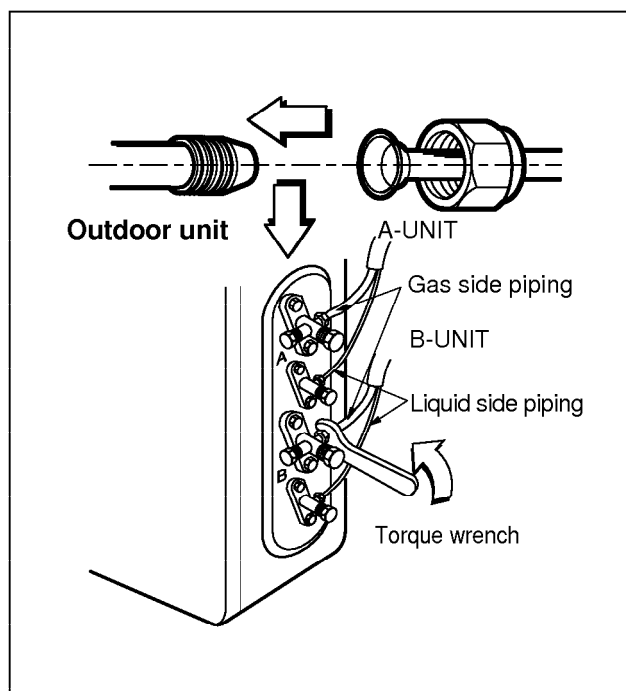

CAUTION

After the confirmation of the above conditions, prepare the wiring as follows:

- 1) Never fail to have an individual power specialized for the air conditioner. As for the method of wiring, be guided by the circuit diagram pasted on the inside of control box cover.
- 2) Provide a circuit breaker switch between power source and the unit.
- 3) The screw which fasten the wiring in the casing of electrical fittings are liable to come loose from vibrations to which the unit is subjected during the course of transportation. Check them and make sure that they are all tightly fastened. (If they are loose, it could give rise to burn-out of the wires.)
- 4) Specification of power source.
- 5) Confirm that electrical capacity is sufficient.
- 6) See to that the starting voltage is maintained at more than 90 percent of the rated voltage marked on the name plate.
- 7) Confirm that the cable thickness is as specified in the power sources specification. (Particularly note the relation between cable length and thickness.)
- 8) Never fail to equip a leakage breaker where it is wet or moist.
- 9) The following troubles would be caused by voltage drop-down.
 - Vibration of a magnetic switch, damage on the contact point there of, fuse breaking, disturbance to the normal function of a overload protection device.
 - Proper starting power is not given to the compressor.

2) Connection of the cable

1. Remove the cover control from the unit by loosening the screw.
Connect the wires to the terminals on the control board individually as the following.

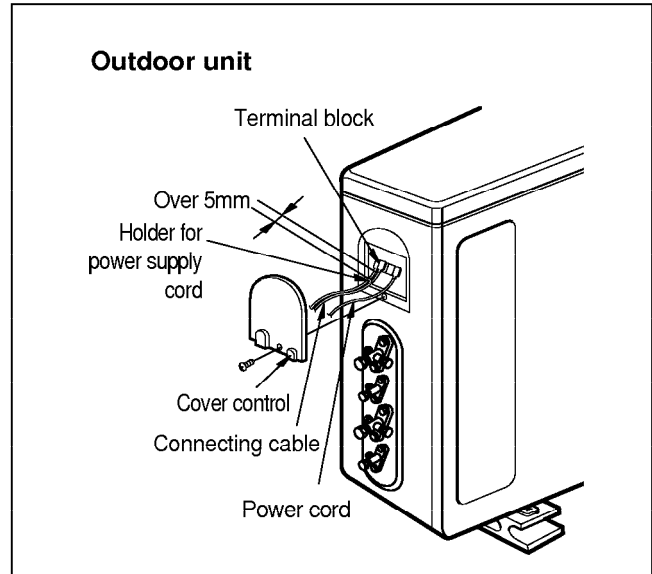
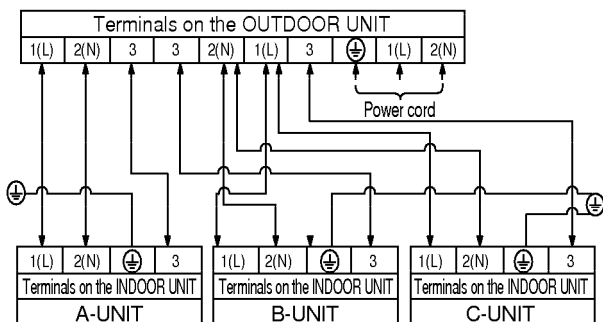
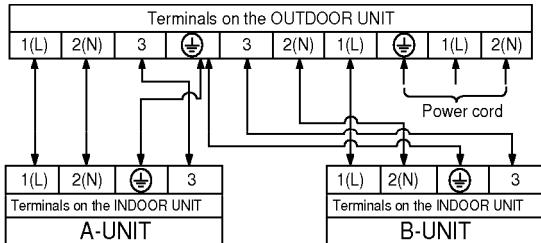

2. Secure the cable onto the control board with the holder (clammer).
3. Refix the cover control to the original position with the screw.
4. Use a recognized circuit breaker between the power source and the unit. A disconnection device to adequately disconnect all supply lines must be fitted.

CAUTION

The power cord connected to the outdoor unit should be complied with the following specifications (Rubber insulation, type H05RN-F approved by HAR or SAA).

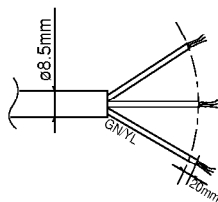

NORMAL CROSS-SECTIONAL AREA
2.5mm²

The connecting cable connected to the indoor and outdoor unit should be complied with the following specifications (Rubber insulation, type H07RN-F approved by HAR or SAA).

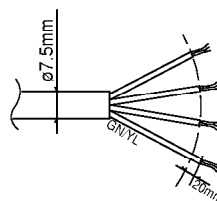

NORMAL CROSS-SECTIONAL AREA
0.75mm²

(4) Checking the Drainage and Pipe forming

1) Checking the Drainage

1. Remove the Grille from the cabinet

- Set the up-and-down air direction louver to open position(horizontally) by finger pressure.
- Remove the securing screws.
- To remove the Grille, pull lower the left and right side of the grille toward you (slightly tilted) and lift it straight upward.

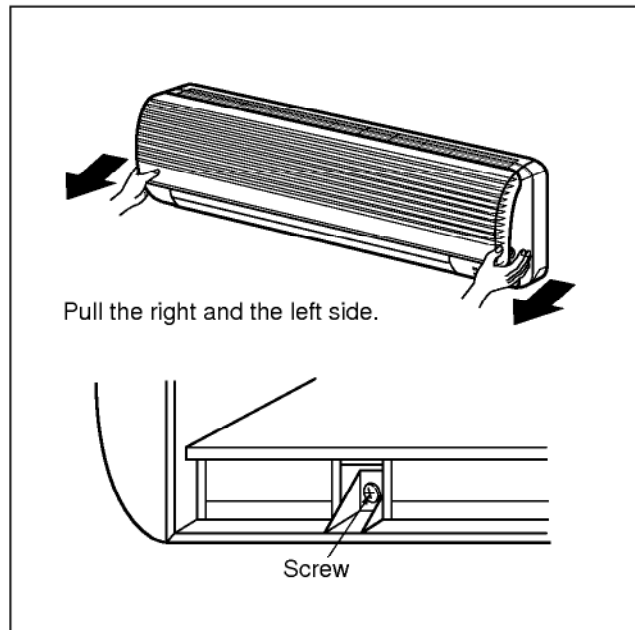

2. Check the drainage

- Pour a glass of water on the evaporator.
- Ensure if water flows drain hose of indoor unit without any leakage.

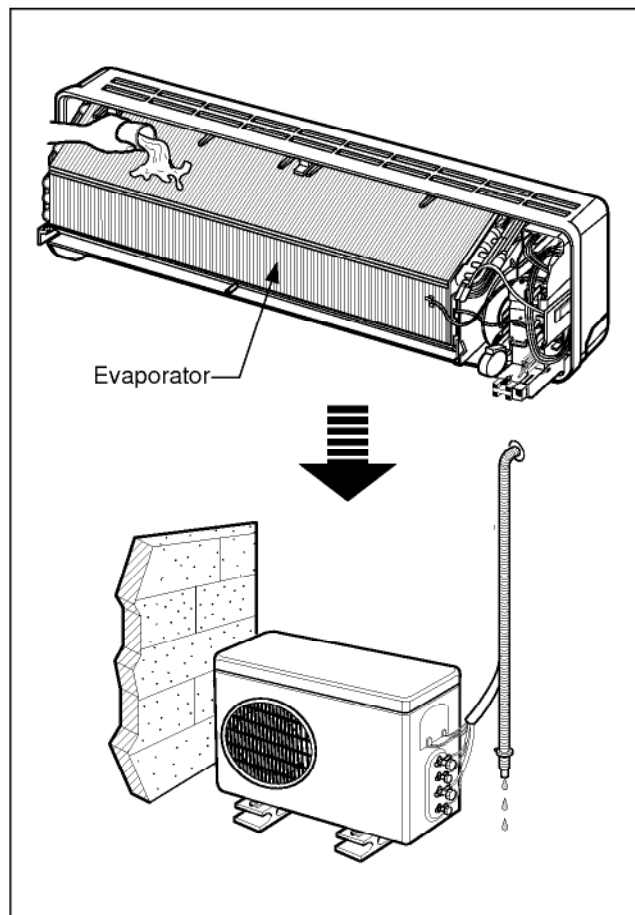

2) Connect the cable to the indoor unit

1. Connect the wires to the terminals on the control board individually according to the outdoor unit connection.

- Ensure that the color of the wires of outdoor unit and the terminal No. are the same as those of indoor unit respectively.

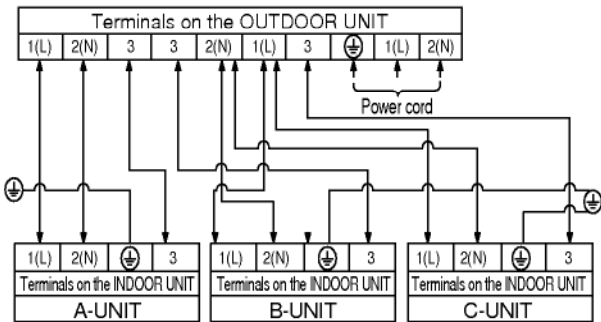
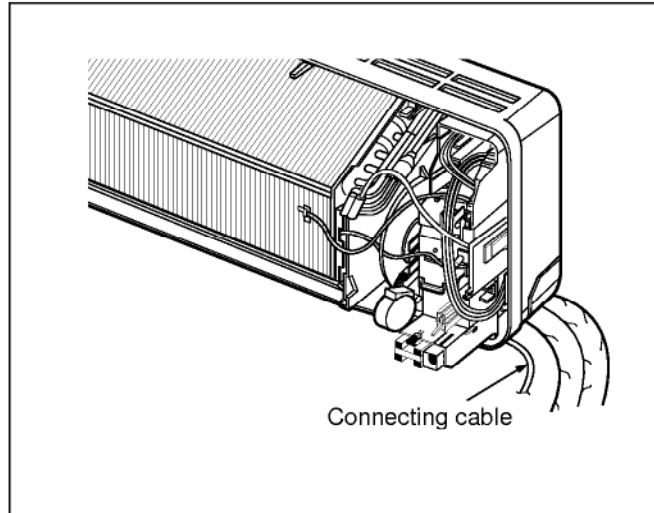
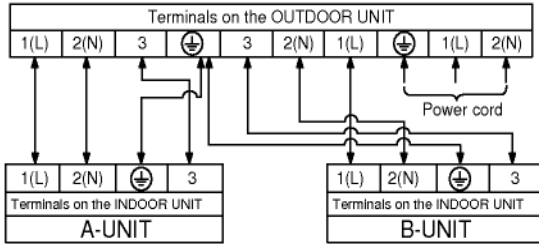

2. Attach the Grille onto the cabinet.

- Grasp lower the left and right side of the Grille and engage four tabs on the top inside edge of the chassis.
- Press the Grille toward the chassis until it will be back into place.

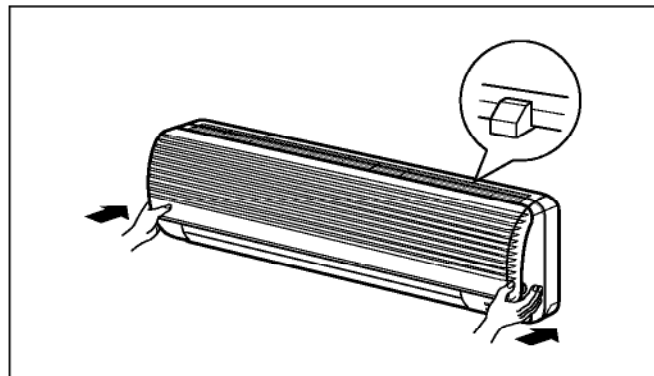

3) Form the pipings

1. Wrap the connecting portion of indoor unit with the Insulation material and secure it with two Plastic Bands(for the right pipings).

- If you want to connect an additional drain hose, the end of the drain-outlet should keep distance from the ground.(Do not dip it into water, and fix it on the wall to avoid swinging in the wind.)

In case of the Outdoor unit is installed below position of the Indoor unit.

2. Tape the Pipings, drain hose and Connecting Cable from down to up.
3. Form the pipings gathered by taping along the exterior wall and fix it onto the wall by saddle or equivalent.

In case of the Outdoor unit is installed upper position of the Indoor unit.

1. Tape the Pipings and Connecting cable from down to up.
2. Form the pipings gathered by taping along the exterior wall and the Trap to be required to prevent the room from entering the water.
3. Fix the pipings onto the wall by saddle or equivalent.

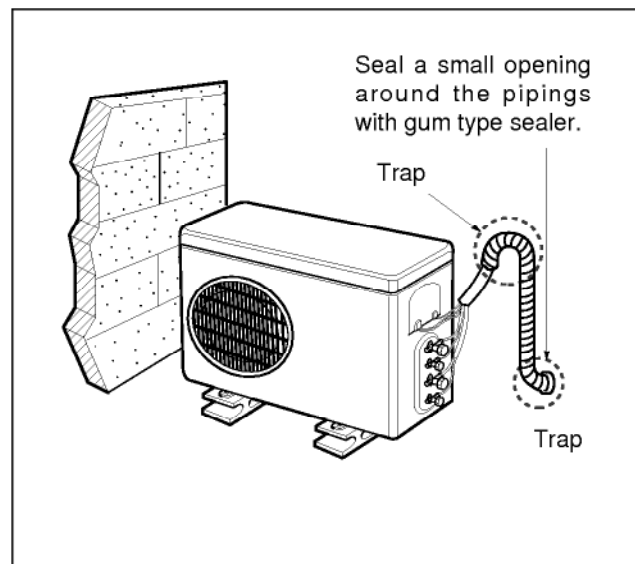
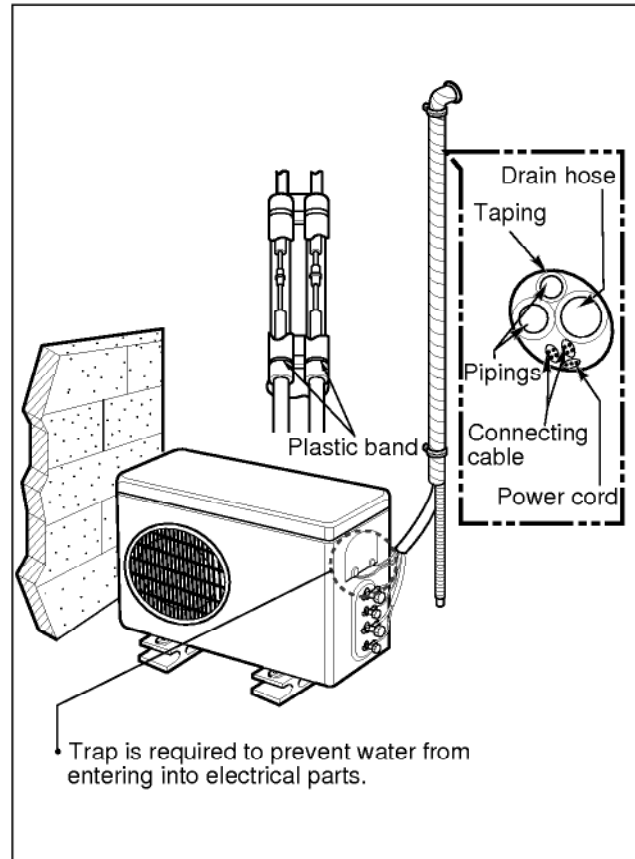

(5) Air Purging of the Pipings and indoor unit

The air which contains moisture remaining in the is refrigeration cycle may cause a malfunction on the compressor.

1. Confirm that both the liquid side valve and the gas side valve are set to the closed position.
2. After connecting the piping, check the joints for gas leakage with gas leak detector.
3. Remove the service port nut, and connect the gauge manifold and the vacuum pump to the service port by the charge hose.
4. Vacuum the indoor unit and the connecting pipes until the pressure in them lowers to below-76cmHg.
5. Disconnect the charge hose and fit the nut to the service port.
(Tightening torque: 1.8kg·m)
6. Remove the valve stem nuts, and fully open the stems of the 2-way and 3-way valves with a hexagon wrench.
7. Tighten the valve stem nuts of the 2-way valve and 3-way valve.

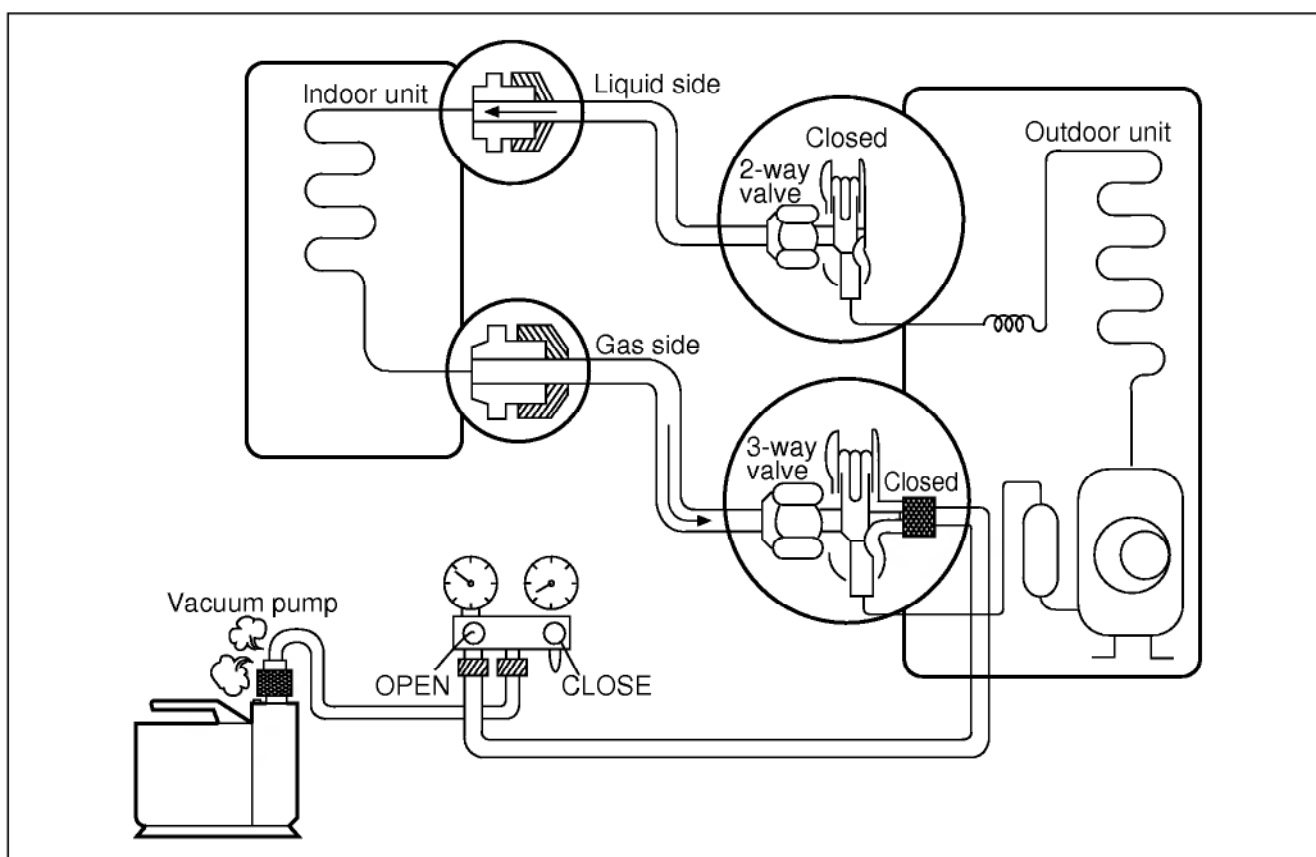

(6) Preventive function of cable mis-connection(Cooling & Heating)

This product has a preventive function of cable mis-connection. In case of mis-connection (in case that the cables between indoor and outdoor units have not been connected properly), it gives a warning signal of LED flickering 3 minutes after starting operation. (Press the forced operation key more than 3 seconds.)

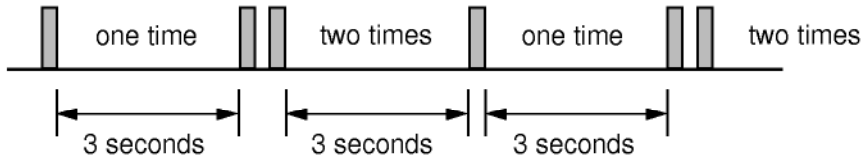

CAUTION

Don't turn on all the indoor units all at once when you check the connection status. In that case the sensor can not be operated properly.

(7) Maximum Length of Pipe and Freon Extra Charge

Charge amount per 1 m

Type	Capacity (Btu/h)	STANDARD LENGTH(m)	CONNECTION TYPE				Charge am't(g) per 1m
			A	B	C	D	
Cooling Only	~7000	4	7	15	7	15	20
	~9000	4	7	15	7	15	20
	~12000	4	7	15	7	15	20
	~18000	5	7	15	7	15	40
	~24000	5	7	15	7	15	40
Heat Pump	~7000	4	5	10	5	10	20
	~9000	4	5	10	5	10	20
	~12000	4	5	10	5	10	20
	~18000	5	5	15	5	15	40
	~24000	5	5	15	5	15	40

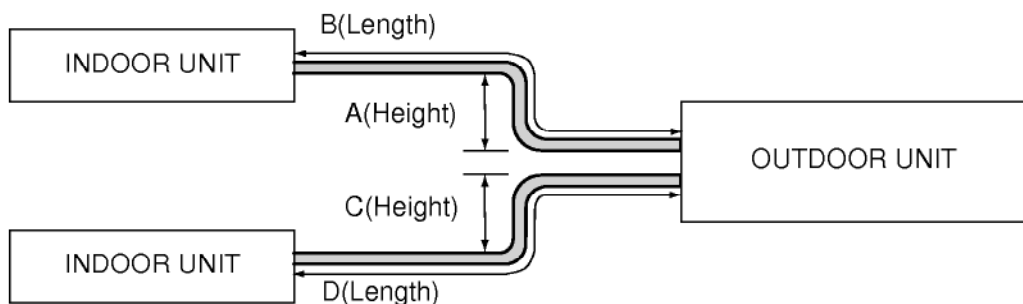

** A, B mean indoor unit higher located than outdoor unit.
C, D mean outdoor unit higher located than indoor unit.

(8) Test running

1) Connection of power supply

1. Connect the power supply cord to the independent power supply.

2. Prepare the remote control.

- Insert two batteries provided.
Remove the battery cover from the remote controller.
- Slide the cover according to the arrow direction.
Insert the two batteries.
(Two "R03" or "AAA" dry-cell batteries or equivalent.)
- Be sure that the (+) and (-) directions are correct.
- Be sure that both batteries are new.
Re-attach the cover.
- Slide it back into position.

3. Operate the unit at cooling operation mode for fifteen minutes or more.

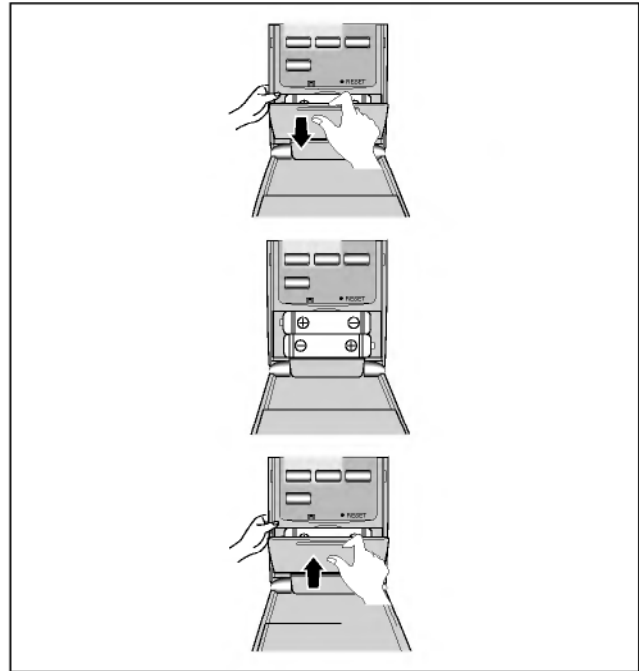

Settlement of Outdoor Unit

- Anchor the outdoor unit with a bolt and nut ($\varnothing 10\text{cm}$) tightly and horizontally on a concrete or rigid mount.
- When installing on the wall, roof or rooftop, anchor the mounting base securely with a nail or wire assuming the influence of wind and earthquake.
- In the case when the vibration of the unit is conveyed to the house, settle the unit with an anti-vibration rubber.

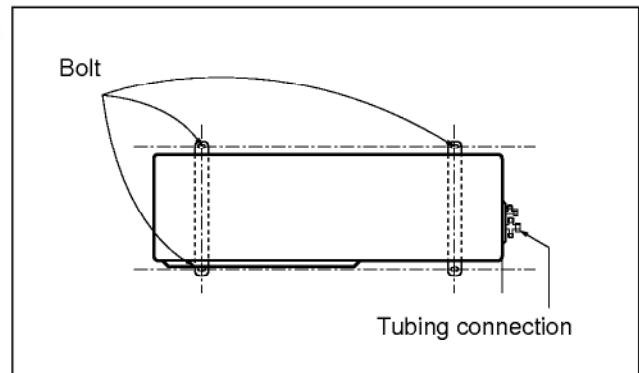

2) Evaluation of the performance

1. Measure the temperature of the intake and discharge air.

2. Ensure the difference between the intake temperature and the discharge one is more than 8°C.

