

This Owner's Manual is provided and hosted by [Appliance Factory Parts](#).



FIELD CONTROLS UV-28HP Owner's Manual

[Shop genuine replacement parts for FIELD CONTROLS
UV-28HP](#)



[Find Your FIELD CONTROLS Air Cleaner Parts - Select From 25 Models](#)

----- Manual continues below -----

UV-AIRE® AIR PURIFYING SYSTEM

Model: UV-12C, 18C, 28C, 28, 12HP, 18HP, 28HP, 12HPC, 18HPC, 28HPC



*Exclusive 5 position lamp mounting feature!

ITEMS INCLUDED IN KIT:

- 1- UV-Aire power unit
- 4- Sheet metal mounting screws
- 1- Angled mounting bracket
- 1- Flat mounting bracket
- 1- Duct board mounting bracket
- 1- Ultra Violet Lamp
- 1- Instruction Sheet
- 1- Wing nut
- Caution Labels
- Gasket

UV-C light inhibits the growth and reproduction of germs and bacteria that circulate through a home's heating and air conditioning system. The treatment is a safe, silent, and proven way to make your home a healthier place to live.

SAFETY CONSIDERATIONS



WARNING: Never expose eyes or skin to UV-C light from any source.

- Looking directly at the UV-C light may cause permanent eye damage or blindness.
- Never operate the UV-Aire Air Purifying System out of the plenum.
- Designed for a closed duct system. Do not mount near a return air opening
- All duct openings in direct line of site of the UV light must be sealed with duct tape or equivalent sealing methods.



WARNING: UV light will break down plastic materials not rated for UV exposure:

(Examples: wire insulation, flex duct, drain pans and humidifiers)

- The unit must be mounted at least 30" from the above stated type of materials.
- If it is necessary to mount the unit in direct line of sight of these types of materials, they must be shielded with aluminum foil, aluminum foil tape, or sheet metal.



WARNING: DO NOT mount this unit outdoors.

- This product is designed for indoor installation only (i.e. attics, crawl spaces, basements, etc.).

This product is not sold as a medical device and is not for the purpose of diagnosis of any disease or condition nor for use in the mitigation, treatment, or prevention of any disease or condition.

READ THESE INSTRUCTIONS CAREFULLY AND COMPLETELY BEFORE PROCEEDING WITH THE INSTALLATION.

This device MUST be installed by a qualified agency in accordance with the manufacturer's installation instructions. The definition of a qualified agency is: any individual, firm, corporation or company which either in person or through a representative is engaged in, and is responsible for, the installation and operation of HVAC appliances, who is experienced in such work, familiar with all the precautions required, and has complied with all the requirements of the authority having jurisdiction.

Please retain these instructions after installation.

Installed By: _____ Phone: _____ Installation Date: _____



FIELD CONTROLS

www.fieldcontrols.com

INDICATION FOR USE

This product is not sold as a medical device and is not for the purpose of diagnosis of any disease or condition nor for use in the mitigation, treatment, or prevention of any disease or condition.

GENERAL INFORMATION

There are different size units available, depending on the square footage of your home. See chart below for determining your home's needs.

MODEL	MINIMUM DUCT WIDTH	VOLTS	AMPS	HZ	WATTS	MAX AIR TEMP °F	LAMP INTENSITY AT 1 METER	RECOMMENDED MAX. SQ. FEET
UV-12C	9"	120	0.5	60	30	190°	37 μ W/cm ²	1500
UV-18C	14"	120	0.5	60	30	190°	73 μ W/cm ²	2000
UV-28C	22"	120	1.1	60	60	150°	105 μ W/cm ²	3000
UV-28	22"	120	1.1	60	60	150°	105 μ W/cm ²	3000
UV-12HP	9"	240	0.5	60	30	190°	37 μ W/cm ²	1500
UV-18HP	14"	240	0.5	60	30	190°	73 μ W/cm ²	2000
UV-28HP	22"	240	1.1	60	60	150°	105 μ W/cm ²	3000
UV-12HPC	9"	240	0.5	60	60	190°	37 μ W/cm ²	1500
UV-18HPC	14"	240	0.5	60	30	190°	73 μ W/cm ²	2000
UV-28HPC	22"	240	1.1	60	30	150°	105 μ W/cm ²	3000

The UV-12C, 18C, 28C, 12HPC, 18HPC, and 28HPC units are equipped with a circuit board to monitor the operation of the UV lamp; it indicates the operation of the lamp through an LED indicator light mounted on the cover of the unit. The circuit board indicates good operation of the lamp by a continuous GREEN color on the LED light. After 8,320 hours of lamp operation, the circuit board indicates the elapsed time of lamp operation by a continuous YELLOW color on the LED light and the internal alarm will beep every 15 minutes. After 9,000 hours of lamp operation, the circuit board indicates the elapsed time of lamp operation by a continuous RED color on the LED light and the internal alarm will beep every 5 minutes. The board also checks if the UV lamp is burned out. If the lamp is burned out, the circuit board will indicate this by a continuous RED color on the LED and the internal alarm will beep every 5 minutes.



WARNING: Before installing or servicing a humidifier, air filter, heat system, or this unit, etc., always turn all power OFF and have units unplugged. Electrical shock can cause personal injury or death. Never expose eyes or skin to direct UV-C light from any source.



WARNING: To prevent water damage or electric shock, do not mount unit under a humidifier.



WARNING: Designed for a closed duct system. Do not mount near a return air opening.



WARNING: This product is designed for indoor installation only (i.e. attics, crawl spaces, basements, etc.). For use on gas fired, oil fired, electric and split system heat pump forced air systems*. This product is NOT designed to be mounted outside on gas fired or heat pump packaged units**.

* Split system heat pumps are systems where the air handler and the air conditioning compressor are separate units.

**Packaged units are systems where the air handler and the air conditioning compressor are built together and are installed outside of the building.



WARNING: Never expose eyes or skin to UVC light from any source. Looking directly at the UVC light may cause permanent eye damage or blindness. **Never operate the UV-Aire Air Purifying System out of the plenum.** Avoid touching the glass portion of the lamp with your hands.

INSTALLATION

1. Locate a suitable location for the unit downstream from the 'A' coil in the supply plenum or in the return plenum; preferably downstream from the air filter. For optimum cleaning effect on the 'A' coil, mount the unit in the supply plenum as close as possible to the 'A' coil. (See Figure 1)

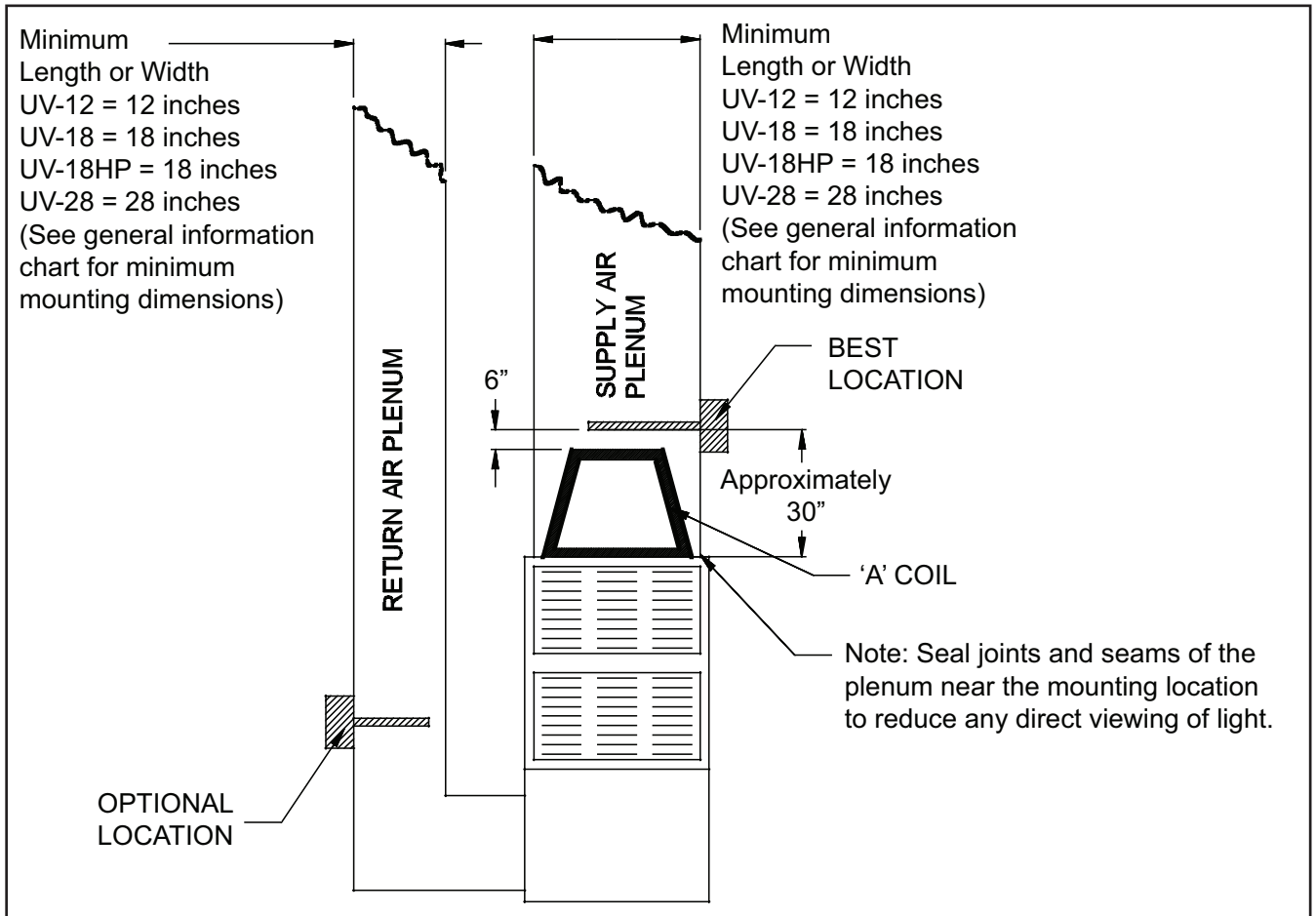

Figure 1

WARNING: Never expose eyes or skin to UVC light from any source. Looking directly at the UVC light may cause permanent eye damage or blindness. Never operate the UV-Aire Air Purifying System out of the plenum. Avoid touching the glass portion of the lamp with your hands.

2. Determine the type of duct you have.

IF YOU HAVE FLEX DUCT

For installations on duct systems with a metallic main duct and flex duct branches, follow the instructions in figure 2A below.

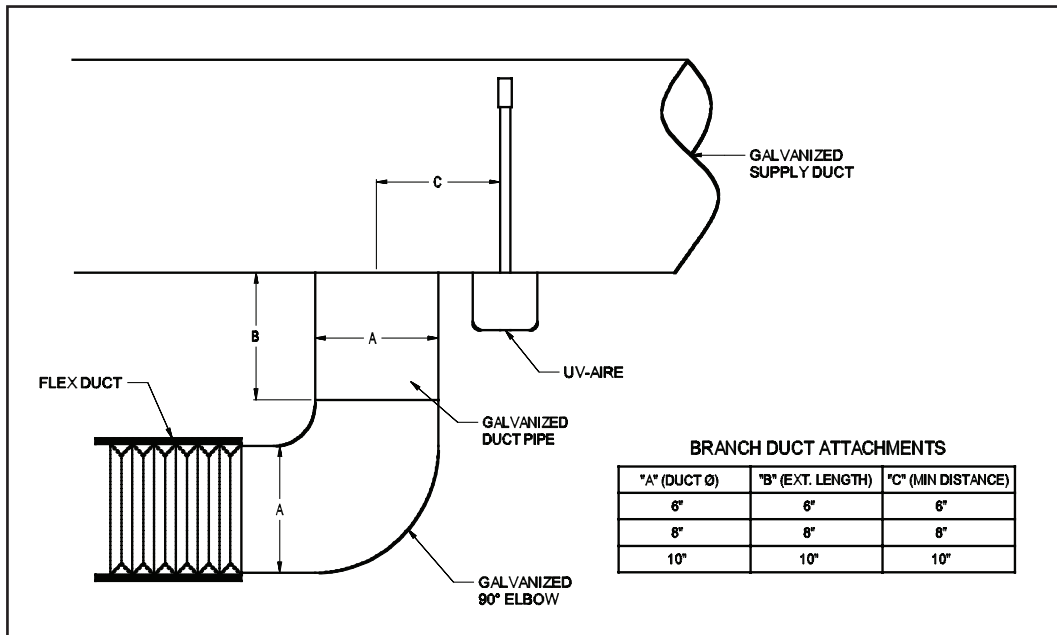

Figure 2A

IF YOU HAVE METAL DUCT:

- Apply supplied wet and stick mounting template to air duct in either a vertical or horizontal position as shown in Figure 2B.
- Drill 1/8" diameter mounting holes at positions indicated on template.
- Cut out the marked openings on the template. (Refer to template as shown in Figure 2B)
- Remove the paper template from the duct.

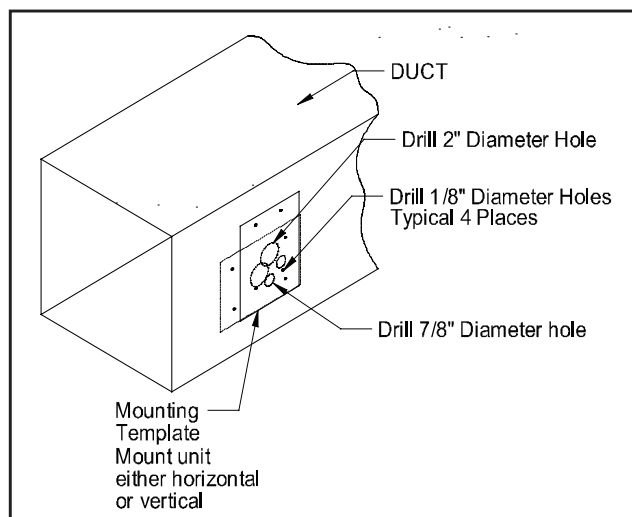

Figure 2B

WARNING: Never expose eyes or skin to UVC light from any source. Looking directly at the UVC light may cause permanent eye damage or blindness. **Never operate the UV-Aire Air Purifying System out of the plenum.** Avoid touching the glass portion of the lamp with your hands.

IF YOU HAVE DUCT BOARD:

- a. Mount the supplied metal mounting plate onto the duct with duct tape in either a vertical or horizontal position. (See Figures 2B & 3)
- b. Bend tabs outward as shown in Figure 4.
- c. Using a knife or blade, cut out a rectangle opening in the duct using the mounting plate as a template. (See Figure 5)
- d. Remove the cut piece of duct. (See Figure 6)
- e. Bend both tabs down and through duct at first bend point. (See Figures 7 & 8)
- f. Bend both tabs at the second bend point up or down to pinch the duct material and grip the duct material. (See Figures 9 & 10)
- g. Using a screwdriver or pointed object, locate mounting holes by poking holes through the duct tape. (See Figure 11)



Figure 3



Figure 4



Figure 5

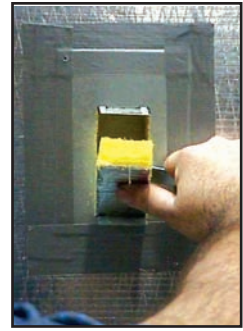

Figure 6



Figure 7



Figure 8



Figure 9



Figure 10

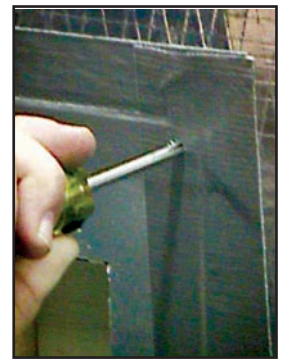

Figure 11

⚠ WARNING: Never expose eyes or skin to UVC light from any source. Looking directly at the UVC light may cause permanent eye damage or blindness. **Never operate the UV-Aire Air Purifying System out of the plenum.** Avoid touching the glass portion of the lamp with your hands.

3. Remove base unit and cover from box.
4. Apply supplied Duct Seal Kit according to instructions included in kit. (See Figure 12)
5. Determine whether to use flat or angled bracket. (Refer to Bulb Mounting Bracket Selection)
 - a. Flat Bracket Installation
 - i. Remove the two hex nuts and flat bracket from included bagged hardware.
 - ii. Install the flat bracket and secure to the unit base with the hex nuts provided. (See Figure 13)
 - b. Angled Bracket Installation



Figure 12

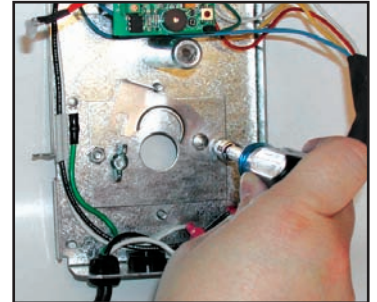

Figure 13

NOTE: For angled bracket mounting, refer to specifications outlined by Charts A & B for mounting distances in the Angled Lamp Mounting Bracket Specifications.

- i. Remove the two hex nuts and angled bracket from included bagged hardware.
- ii. Install the angled bracket and secure to the unit base with the hex nuts provided. (See Figure 14)

NOTE: Be sure to note location of lamp hole in bracket relative to unit base.

6. Mount the unit base to the duct using the four mounting screws provided. (See Figure 15)
7. Remove tag and alcohol wipe from lamp. Wipe off lamp being sure not to touch lamp with bare hands. The oils in your hands cause a reduction in lamp output.
8. Insert lamp through the hole until lamp cannot be inserted any further. (See Figure 16)

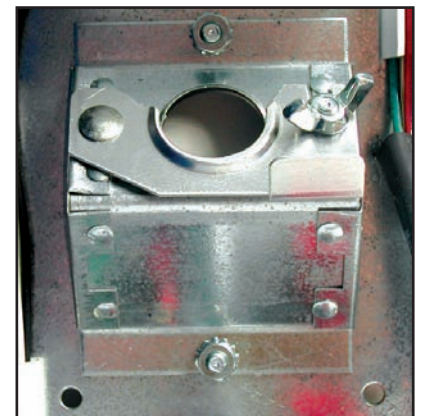

Figure 14

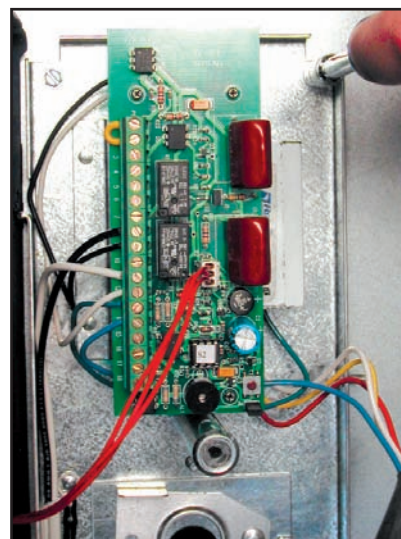

Figure 15

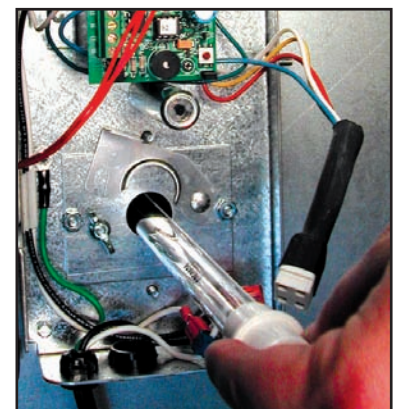

Figure 16

WARNING: Never expose eyes or skin to UVC light from any source. Looking directly at the UVC light may cause permanent eye damage or blindness. Never operate the UV-Aire Air Purifying System out of the plenum. Avoid touching the glass portion of the lamp with your hands.

9. Swing the swivel bracket over the end of lamp. Hand-tighten the wing nut on the stud. Be careful not to over tighten the wing nut. The porcelain at the lamp base may crack when over tightened. (See Figure 17)
10. Plug ballast plug into end of lamp. (See Figure 18)
11. Snap cover onto the unit base. (See Figure 19)
12. Plug the LED wire from the cover onto the board. (See Figure 20)
13. Close the cover and tighten cover screw. (See Figure 21)
14. Plug the power cord into a standard electrical outlet.

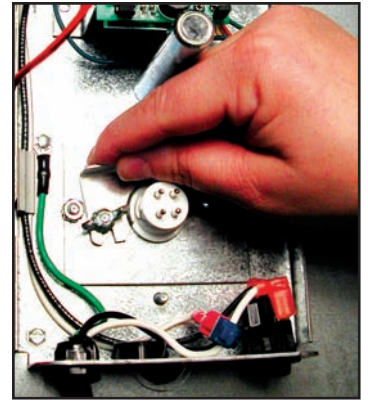

Figure 17

NOTE: Seal the joints and seams of the plenum near the mounting location to reduce any direct viewing of light. (See Figure 1)

15. Press the power switch to the ON position. (Light on switch should be on, indicating power.)
16. Look through view port in the box cover to be sure the lamp is working. You should see a blue glow. (The view port is covered with a plastic lens that blocks the UVC rays.) If equipped, the LED light will show a continuous GREEN color indicating proper unit operation.
17. If the lamp is not glowing, follow steps 8-14 again. If lamp still does not glow, contact technical support at 252-522-3031 for further assistance.

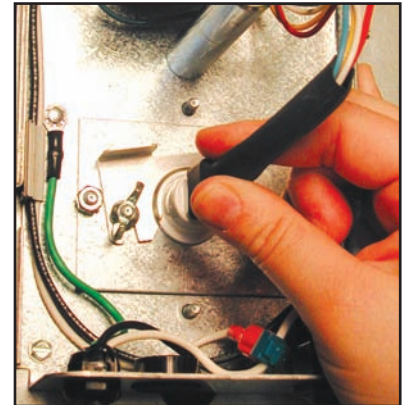

Figure 18

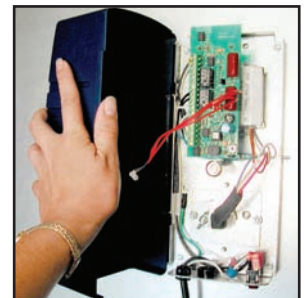

Figure 19

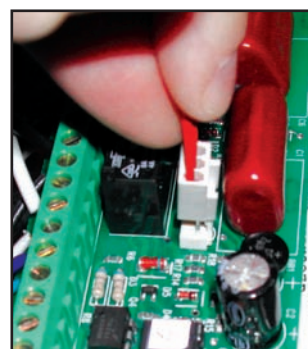

Figure 20



Figure 21

WARNING: Never expose eyes or skin to UVC light from any source. Looking directly at the UVC light may cause permanent eye damage or blindness. **Never operate the UV-Aire Air Purifying System out of the plenum.** Avoid touching the glass portion of the lamp with your hands.

INCORPORATING A THERMOSTAT (Be sure to follow any applicable state or local codes.)

The UV Aire units supplied with a circuit board allow for the automatic operation of the UV lamp when there is a call for heating or cooling by the thermostat. After the call for heat has been satisfied, the UV Aire unit will operate for 45 minutes then shut off.

1. Turn off power switch on the UV Aire unit and unplug the unit before doing any wiring.
2. Loosen the cover screw and open the unit cover.
3. Locate terminals 1-2 on the circuit board and remove the jumper wire.
4. Wire to terminals W, C and G into the fan center on the furnace. Refer to Diagram A for proper wiring.
5. Close the cover and secure with the cover screw. Then plug the UV Aire back into the power receptacle and switch the power switch to the "ON" position.

SYSTEM CHECK OUT PROCEDURE:

1. With the thermostat set to the heating mode, adjust the thermostat for a call for heat. The furnace and the UV Aire should start operating. Turn down the thermostat to stop the call for heat. After 45 minutes, the UV Aire lamp will turn off.
2. With the thermostat set to the cooling mode, adjust the thermostat for a call for cooling. The furnace and the UV Aire should start operating. Turn up the thermostat to stop the call for cooling. After 45 minutes, the UV Aire lamp will turn off.

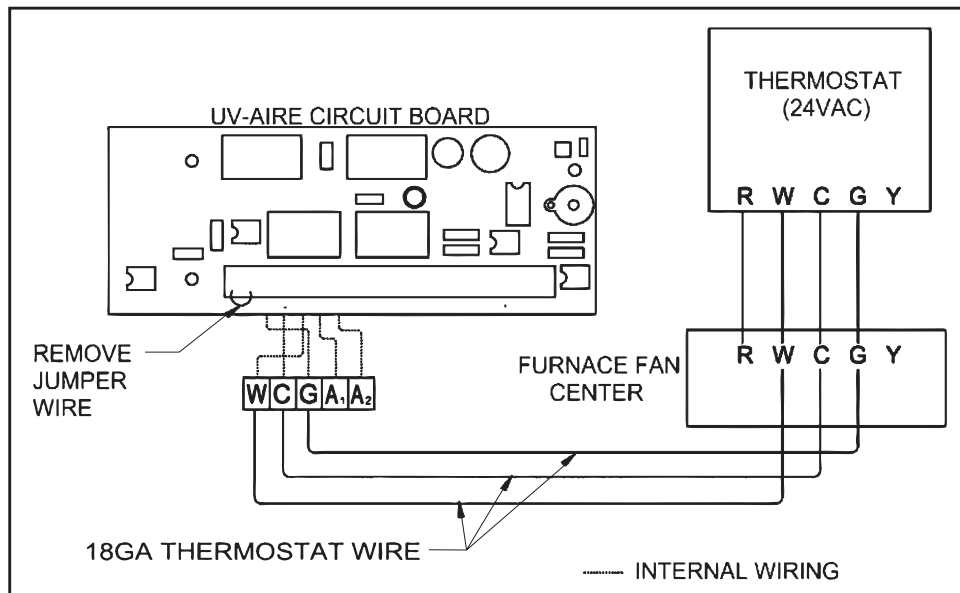

Diagram A

ALARM CIRCUIT WIRING

The UV Aire units supplied with a circuit board allow for the wiring of the UV Aire unit into an alarm or security system to monitor the operation of the UV lamp. This circuit is a set of normal open contacts that close if the operational time exceeds 9000 hrs or if the lamp burns out.

1. Turn off power switch on the UV Aire unit and unplug the unit before doing any wiring.
2. Loosen the cover screw and open the unit cover.
3. Locate terminals 1-2 on the circuit board and remove the jumper wire.
4. Wire to terminals A1-A2 and wire in accordance with Diagram B.

WARNING: Never expose eyes or skin to UVC light from any source. Looking directly at the UVC light may cause permanent eye damage or blindness. Never operate the UV-Aire Air Purifying System out of the plenum. Avoid touching the glass portion of the lamp with your hands.

SYSTEM CHECK OUT PROCEDURE

1. Plug the UV Aire back into the power receptacle and leave the power switch in the OFF position.
2. Unplug the Ballast connector from the lamp and switch the power switch to the ON position. The unit will start and operate for approximately 10 seconds. Then the LED will switch to a RED color and the alarm contact will close.
3. Switch the power switch to the OFF position and reconnect the ballast connection to the lamp. Close the cover, secure with the cover screw, and switch the power switch to the ON position.

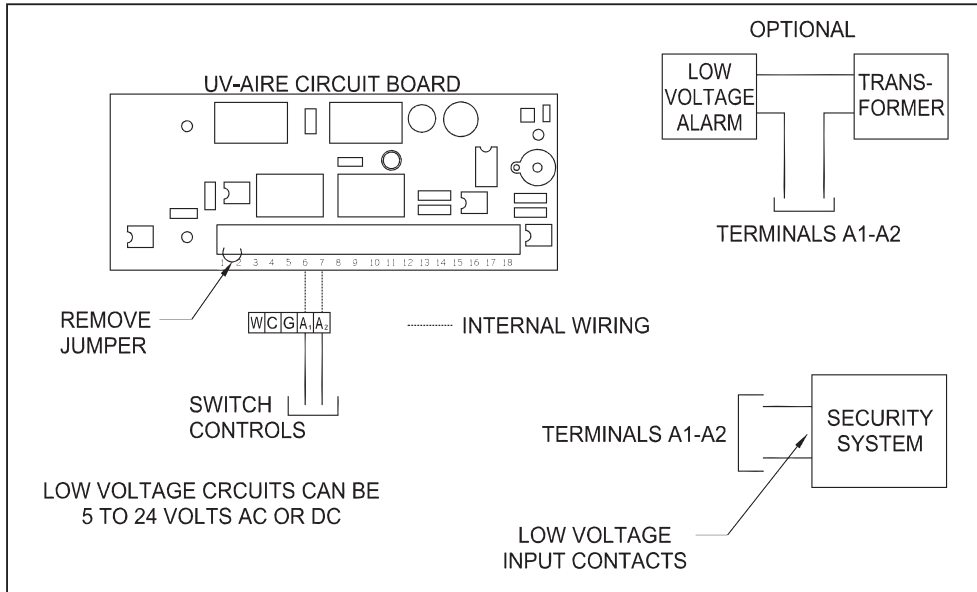
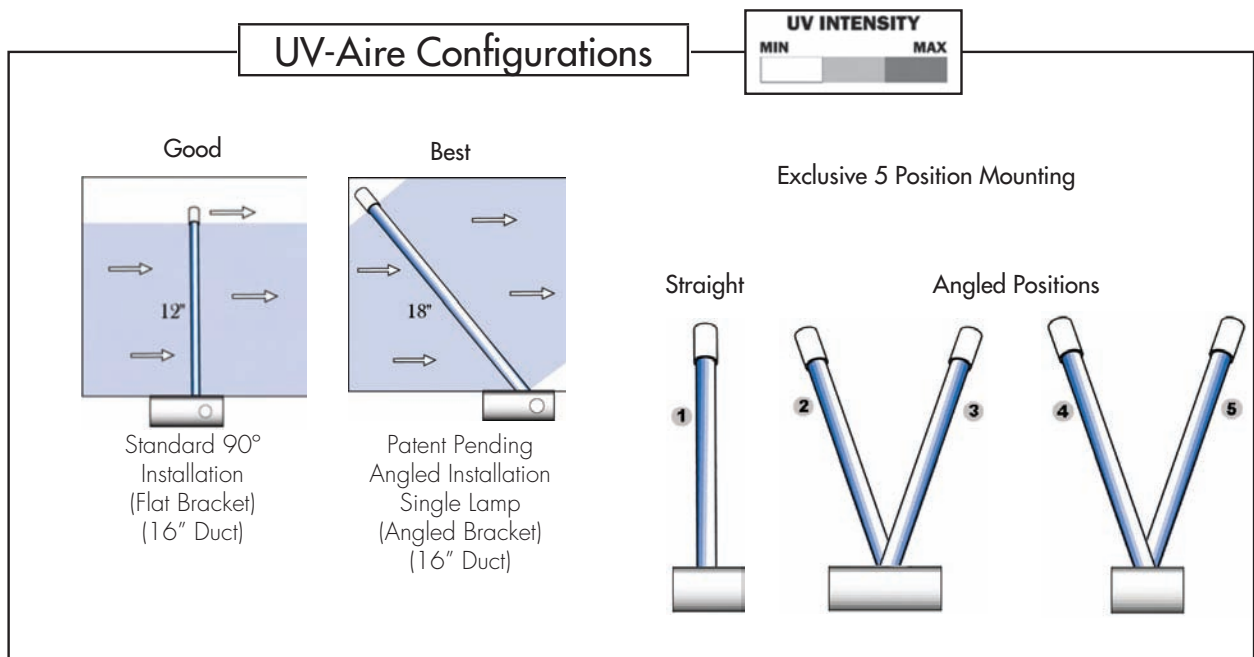

Diagram B

BULB MOUNTING BRACKET SELECTION

The UV-AIRE units come with an angled mounting bracket and flat mounting bracket to position the bulb either straight or at an angle. Choose one or the other bracket method best suited for your needs. Refer to the configurations chart below when making your selection.



WARNING: Never expose eyes or skin to UVC light from any source. Looking directly at the UVC light may cause permanent eye damage or blindness. **Never operate the UV-Aire Air Purifying System out of the plenum.** Avoid touching the glass portion of the lamp with your hands.

ANGLED LAMP MOUNTING BRACKET SPECIFICATIONS

Use the specifications below to determine allowable clearances for proper mounting of the UV-Aire unit on the duct.

LAMP OFFSET DIMENSIONS			
Unit	Min. Duct Size (inches)	A	B
UV-12C	9 x 12	8½	6½
UV-18C	14 x 18	13½	10 ⁵ / ₁₆
UV-28C	22 x 24	21 ³ / ₈	16¼
UV-28	22 x 24	21 ³ / ₈	16¼
UV-12HP	9 x 12	8½	6½
UV-18HP	14 x 18	13½	10 ⁵ / ₁₆
UV-28HP	22 x 24	21 ³ / ₈	16¼
UV-12HPC	9 x 12	8½	6½
UV-18HPC	14 x 18	13½	10 ⁵ / ₁₆
UV-28HPC	22 x 24	21 ³ / ₈	16¼

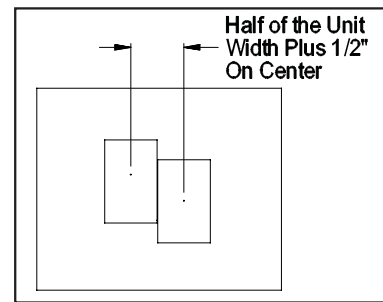

Chart A

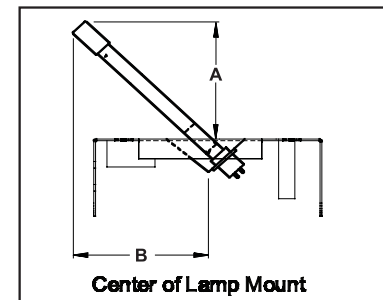

Chart B

MAINTENANCE

1. Inspect and clean lamp at least every 6 months.
2. Replace your UV-Aire Air Purifying System lamp once a year to maintain the lamp's maximum output intensity. The lamp should operate continuously for maximum lamp life and light effectiveness.

REPLACEMENT PROCEDURE

VERY IMPORTANT: Turn switch on unit to OFF position and unplug unit from outlet.

1. Loosen the cover screw on the side of the unit and open cover.
2. Unplug ballast plug from end of lamp.
3. Loosen the wing nut on swivel bracket and rotate the swivel bracket clockwise.

NOTE: When replacing the lamp, always wipe off lamp before installing.

4. Slide lamp out carefully and dispose of properly.

NOTE: UV lamps contain a small amount of mercury, like a typical fluorescent lamp. Check with your local waste management authority for local disposal or recycling requirements. According to the EPA's Universal Waste Rule, these types of lamps may be disposed of into household waste

5. Insert the lamp through the mounting hole and secure the lamp by rotating the swivel bracket counter-clockwise into position and secure by tightening wing nut. Be careful not to over tighten the wing nut.
6. Attach ballast plug onto the end of the lamp, close cover and tighten cover screw.
7. Plug in the power cord and press the power switch to the ON position.
8. After replacing lamp, make sure a new Lamp Replacement Label (supplied with lamp replacement) is applied to the housing and dated with the date of installation.

FOR MODELS WITH CIRCUIT BOARD

1. Loosen the cover screw on the side of the unit and open cover.
2. Unplug ballast plug from end of lamp.
3. Loosen the wing nut on swivel bracket and rotate the swivel bracket clockwise.

NOTE: When replacing the lamp, always wipe off lamp before installing.

4. Slide lamp out carefully and dispose of properly.

WARNING: Never expose eyes or skin to UVC light from any source. Looking directly at the UVC light may cause permanent eye damage or blindness. **Never operate the UV-Aire Air Purifying System out of the plenum.** Avoid touching the glass portion of the lamp with your hands.

NOTE: UV lamps contain a small amount of mercury, like a typical fluorescent lamp. Check with your local waste management authority for local disposal or recycling requirements. According to the EPA's Universal Waste Rule, these types of lamps may be disposed of into household waste.

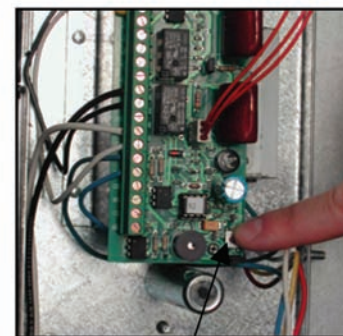

Figure 22

Timer Reset Button

5. Insert the lamp through the mounting hole and secure the lamp by rotating the swivel bracket counter-clockwise into position and secure by tightening wing nut. Be careful not to over tighten the wing nut.
6. Attach ballast plug onto the end of the lamp.
7. Plug in the power cord and press the power switch to the ON position.
8. Press the timer reset button on the circuit board using the eraser end of a pencil or the blunt end of a plastic ink pen. Hold for three seconds. (See Figure 22)
9. Release the timer reset button. The LED on the cover will flash twice, indicating the timer circuit has been reset.
10. Close cover and tighten cover screw.
11. After replacing lamp, make sure a new Lamp Replacement Label (supplied with lamp replacement) is applied to the housing and dated with the date of installation.

TROUBLESHOOTING GUIDE

1. If the LED is illuminating a YELLOW color and the circuit board alarm beeps every 15 minutes, the lamp should be replaced soon.
2. If the LED is illuminating a RED color and the circuit board alarm beeps every 5 minutes, the lamp should be replaced immediately.
3. If the lamp does not light up, replace lamp.
4. If the lamp still does not light up after replacing the lamp, replace ballast.

REPLACEMENT PARTS LIST

MODEL	LAMP (Field Controls Part Number)	CIRCUIT BOARD (Field Controls Part Number)	BALLAST (Field Controls Part Number)
UV-12C	46365401	46436300	46365511
UV-18C	46365402	46436300	46365512
UV-28C	46365403	46436300	46365510
UV-28	46365403	N/A	46365503
UV-12HP	46365401	N/A	46365511
UV-18HP	46365402	N/A	46365512
UV-28HP	46365403	N/A	46365510
UV-12HPC	46365401	46436300	46365511
UV-18HPC	46365402	46436300	46365512
UV-28HPC	46365403	46436300	46365510

For replacement parts, contact your local heating service company.

Any questions, please contact Field Controls at:

- Phone: 252-522-3031
- Fax: 252-522-0214
- Email: sales@fieldcontrols.com

WARNING: Never expose eyes or skin to UVC light from any source. Looking directly at the UVC light may cause permanent eye damage or blindness. **Never operate the UV-Aire Air Purifying System out of the plenum.** Avoid touching the glass portion of the lamp with your hands.

LIMITED WARRANTY

Field Controls, LLC ("Company") warrants that its products shall be free from defects in material and workmanship under normal use for the limited period indicated, **from the date of manufacture, subject to the provisions 1-8 below.**

Eighteen (18) months

All Field Controls Products (except for those listed below as 5 years or 90 days).

Five (5) years

Field Controls Direct Vent Systems (FDVS), Field Oil Vent Kits (FOVP), and ComboVents (CV).

Field Controls warrants that the products listed below shall be free from defects in material and workmanship under normal use for the limited period indicated, **from the date of purchase by the consumer, subject to the provisions 1-8 below.**

Ninety (90) days

UV lamps/bulbs

Provisions:

1. During the limited warranty period, Company, or its authorized service representative, will repair or replace, at Company's option, without charge, a defective Product. Product that is repaired may be repaired with new or refurbished replacement parts. Product that is replaced may be replaced with a new or refurbished product of the same or similar design. Company will return repaired or replacement Product to customer in working condition. Labor charges are not covered as part of the limited warranty.
2. With regard to UV lamps/bulbs, customer shall be required to include a "valid proof of purchase" (sales receipt) identifying the Product purchased (Product model or accurate date code information) and the date the Product(s) was purchased.
3. Product whose warranty/quality stickers, Product serial number plates or electronic serial numbers have been removed, altered or rendered illegible shall not be covered under the limited warranty.
4. Defective Product must be returned to Company, postage prepaid.
5. IN NO EVENT SHALL COMPANY BE LIABLE FOR ANY INDIRECT, SPECIAL, INCIDENTAL, CONSEQUENTIAL, OR SIMILAR DAMAGES (INCLUDING, BUT NOT LIMITED TO, LOST PROFITS OR REVENUE, INABILITY TO USE PRODUCT, OR OTHER ASSOCIATED EQUIPMENT, THE COST OF SUBSTITUTE EQUIPMENT, AND CLAIMS BY THIRD PARTIES) RESULTING FROM THE USE OF PRODUCT. Some states do not allow the exclusion or limitation of incidental or consequential damages, so the above limitation or exclusion may not apply to you.
6. THIS WARRANTY AND REMEDIES ARE EXCLUSIVE AND IN LIEU OF ALL OTHER WARRANTIES, REMEDIES AND CONDITIONS, WHETHER ORAL, WRITTEN, EXPRESS, STATUTORY OR IMPLIED. TO THE EXTENT PERMITTED BY LAW, COMPANY DISCLAIMS ALL IMPLIED AND STATUTORY WARRANTIES, INCLUDING WARRANTIES OF MERCHANTABILITY AND FITNESS FOR A PARTICULAR PURPOSE.
7. Company makes no warranty of any kind in regard to other manufacturer's products distributed by Company. Company will pass on all warranties made by the manufacturer and where possible, will expedite the claim on behalf of the customer, but ultimately, responsibility for disposition of the warranty claim lies with the manufacturer.
8. Product that has been subjected to misuse, accident, shipping or other physical damage, improper installation or application, abnormal operation or handling, neglect, fire, water or other liquid intrusion are not covered by the warranty.

The health aspects associated with the use of these products and their ability to aid in disinfecting of environmental air have not been investigated by UL.



F I E L D C O N T R O L S

Phone: 252.522.3031 • Fax: 252.522.0214

www.fieldcontrols.com