



MAC 2000 MEDIA AIR CLEANER

INSTALLER: PLEASE FILL OUT AND MAIL GUARANTEE CARD AFTER INSTALLATION IS COMPLETE. LEAVE INSTALLATION INSTRUCTIONS WITH HOME OWNER

This air cleaner is designed for use in systems up to 2000 CFM. For higher airflows additional units may be required. See Typical Installations below.

FOR INSTALLATION IN THE RETURN AIR DUCT OF ANY FORCED AIR HEATING AND COOLING SYSTEM

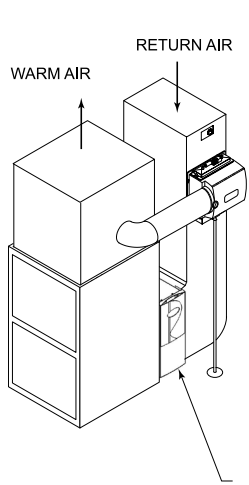

HIGH BOY

GENERALAire MAC 2000
MEDIA AIR CLEANER

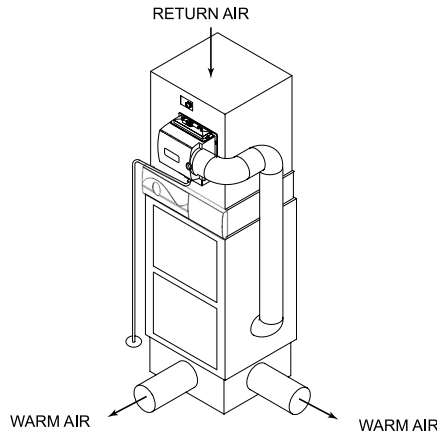

COUNTER-FLOW

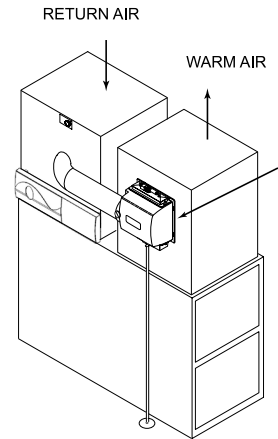

LOW BOY

GENERALAire FLOW THRU
SERIES HUMIDIFIER

INSTALLATION INSTRUCTIONS

IMPORTANT: A 26 INCH CLEARANCE MUST BE ALLOWED FOR REMOVAL OF THE MEDIA CARTRIDGE FROM THE CABINET.

1. Turn off electricity to furnace.
2. Remove front cover.
3. Slide media cartridge from air cleaner cabinet, and discard packing material.
4. Remove and discard existing furnace air filter.
5. Install cabinet in return air system. Properly install airflow direction arrows on interior of cabinet. Duct supports are recommended to support weight of cabinet. See typical installations.
6. Slide the media cartridge into the cabinet. Be sure the airflow arrow on the cartridge is in the same direction as the arrow in the cabinet. The wire mesh is always on the downstream side of the filter media. Replace cover.
7. If a condition indicator is to be used, install on a vertical duct surface between the air cleaner and the furnace blower.
8. Turn on electricity and furnace and check performance of all equipment.

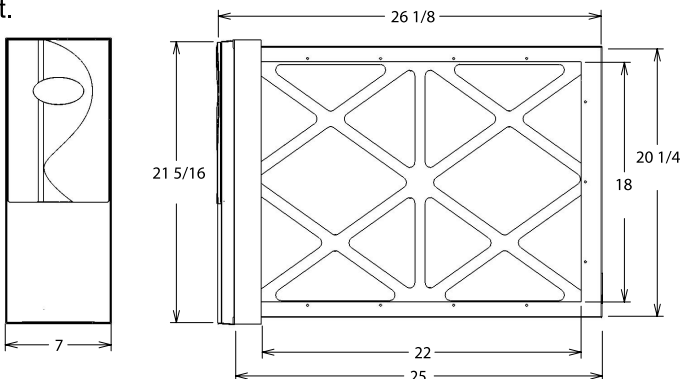

FORM NO.
14044 Rev. B

FILL OUT AND MAIL THIS WARRANTY CARD AND LITERATURE REQUEST FORM

- HEPA AIR CLEANER
- UV AIR PURIFIERS
- ELITE STEAM HUMIDIFIERS
- ELECTRONIC TEMPERATURE COMPENSATING HUMIDISTAT
- HIGH EFFICIENCY AIR CLEANERS
- HUMIDIFIERS
- AIR FILTER GAGE
- FUEL OIL FILTERS AND ACCESSORIES

MAINTENANCE

The Air Cleaner Media 4501 will normally need to be replaced every 4 to 6 months (end of the heating or cooling season) with normal usage. If an air cleaner condition indicator is used, change the media when the device indicates that service is required. Additionally, the frequency of filter replacement can be determined by visual examination.

PARTS LIST

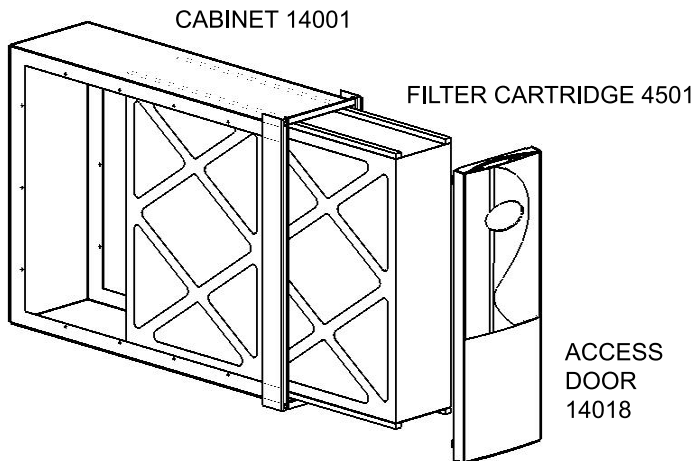

PRESSURE DROP SCHEDULE

CFM	IN W.C.
600	0.04
800	0.06
1000	0.08
1200	0.11
1400	0.14
1600	0.17
1800	0.21
2000	0.26

LIMITED WARRANTY

This air cleaner, if properly registered by the return of the attached warranty registration card to the manufacturer, is warranted to the consumer against defects in materials and workmanship for a period of ten years from the date of installation. The air cleaner media is not covered by this limited warranty or any other warranties.

Any other defective parts will be repaired without charge except for removal, reinstallation and transportation costs. To obtain repair service under this limited warranty, the consumer must send the defective part or the complete unit to the manufacturer.

THERE ARE NO EXPRESS WARRANTIES COVERING THIS AIR CLEANER OTHER THAN AS SET FORTH ABOVE, THE IMPLIED WARRANTIES OF MERCHANTABILITY AND FITNESS FOR A PARTICULAR PURPOSE ARE EXPRESSLY EXCLUDED. THE MANUFACTURER ASSUMES NO LIABILITY IN CONNECTION WITH THE INSTALLATION OR USE OF THIS PRODUCT, EXCEPT AS STATED IN THIS LIMITED WARRANTY. THE MANUFACTURER WILL IN NO EVENT BE LIABLE FOR INCIDENTAL OR CONSEQUENTIAL DAMAGES.

This limited warranty gives you specific legal rights, and you may also have other rights which vary from state to state. Some states do not allow either limitations on implied warranties, or exclusions from incidental or consequential damages, so the above exclusion and limitation may not apply to you. Any questions pertaining to this limited warranty should be addressed to the manufacturer. (U.S.A.: The manufacturer has elected not to make available the informal dispute settlement mechanism which is specified in the Magnuson-Moss Warranty Act.)

GENERAL FILTERS, INC.
43800 GRAND RIVER AVE.
NOVI, MICHIGAN 48375-1115

WWW.GENERALAIRE.COM

CANADIAN GENERAL FILTERS, LTD.
39 CROCKFORD BLVD.
SCARBOROUGH, ONTARIO M1R3B7

WWW.CGFPRODUCTS.COM

LE PROPRIÉTAIRE DOIT REMPLIR LA CARTE
D'ENREGISTREMENT
ET LA POSTER AU :
OWNER FILL IN
REGISTRATION
AND MAIL TO:
GENERAL FILTERS, INC.
43800 GRAND RIVER AVE
NOVI, MI 48375-1115

WARRANTY REGISTRATION

Enregistrement de la garantie

MODEL MAC-2000 Media Air Cleaner

MODÈLE MAC-2000 Média De Purificateur D'air

OWNER'S NAME

Nom du propriétaire:

STREET ADDRESS

Adresse:

CITY

Ville:

DEALERS NAME

Nom du marchand:

STREET ADDRESS

Adresse:

CITY

Ville:

DATE OF INSTALLATION

DATE DE INSTALLATION:

STATE

Province:

CITY

Ville:

STREET ADDRESS

Adresse:

CITY

Ville:

DATE OF INSTALLATION

DATE DE INSTALLATION:

POSTAL CODE

Code postal:

CITY

Ville:

STREET ADDRESS

Adresse:

CITY

Ville:

DATE OF INSTALLATION

DATE DE INSTALLATION:

SERIAL NUMBER

Numéro de Série:

POSTAL CODE

Code postal: