

This Owner's Manual is provided and hosted by Appliance Factory Parts.

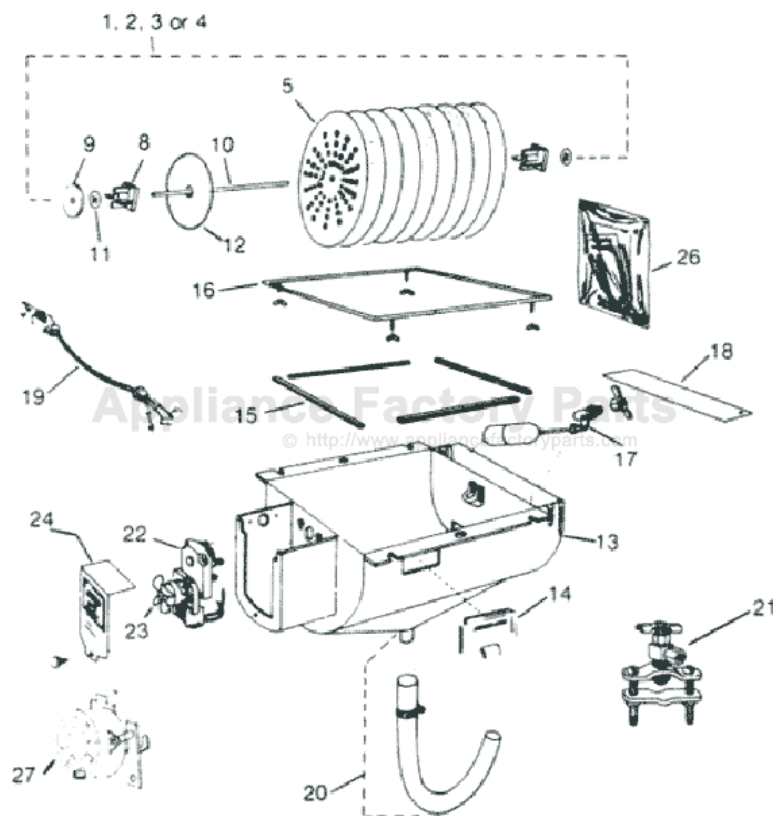

HUMIDAIRE FH-2000 Owner's Manual

[Shop genuine replacement parts for HUMIDAIRE
FH-2000](#)



[Find Your HUMIDAIRE Humidifier Parts - Select From 31 Models](#)

----- Manual continues below -----

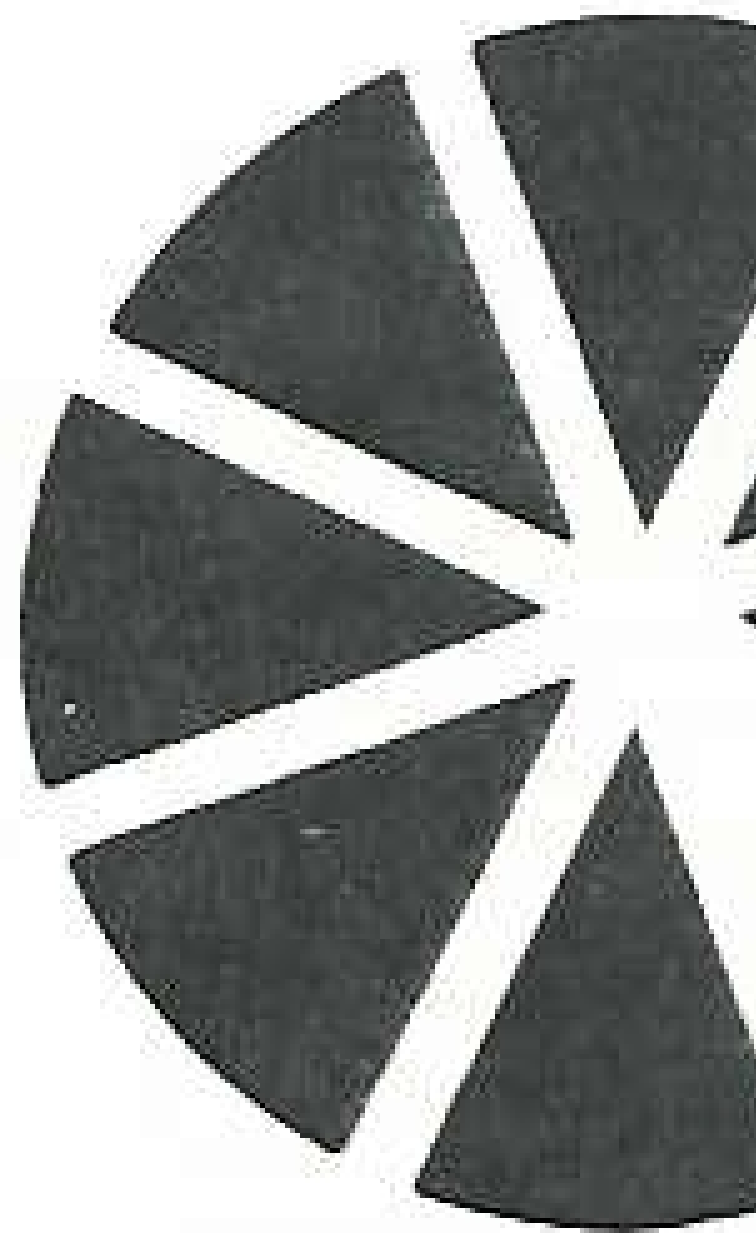

INST

MA

HUMIDIFI

Instructions an

Installation inst
installing on wa

Step One The humidifi
DUCT of your forced air furn
from your furnace and select
close to the furnace proper
the furnace blower will keep

Step Nine It is recommended to use a humidifier to achieve maximum controlled humidity in the home.

Since your humidifier operates on a 240V supply connection coming from a double switch.

CAUTION: YOU ARE WORKING WITH HIGH VOLTAGE. ANY CONNECTIONS, DETERRING FROM THE INSTRUCTIONS IS TO BE USED AND NOT RECOMMENDED. AFTER MAKING ALL THE CONNECTIONS, REPLACE THE FUSE.

TIPS ON



1. Draining The Unit

Regular draining of your humidifier is important because when the unit's output is extremely high, water droplets become suspended in the water in the reservoir. These droplets settle at the bottom of the unit, and drain away during the next draining. follow this draining schedule: