



Internal Use Only

<http://biz.lgservice.com>

Ceiling Duct Type Air Conditioner **SVC MANUAL(Exploded View)**

**MODEL : LB-F3660HL
LB-F3660CL**

CAUTION

Before Servicing the unit, read the safety precautions in General SVC manual.
Only for authorized service personnel.

Contents

Functions	3
Product Specifications (Cooling & Heating)	5
Dimensions	6
Refrigeration Cycle Diagram	7
Wiring Diagram	9
Operation Details	11
Installation of Indoor, Outdoor Unit	14
Test Running	25
3-way Valve	27
Cycle Troubleshooting Guide	32
Electronic Parts Troubleshooting Guide	33
Electronic Control Device	36
Schematic Diagram	37
Exploded View	38

Functions

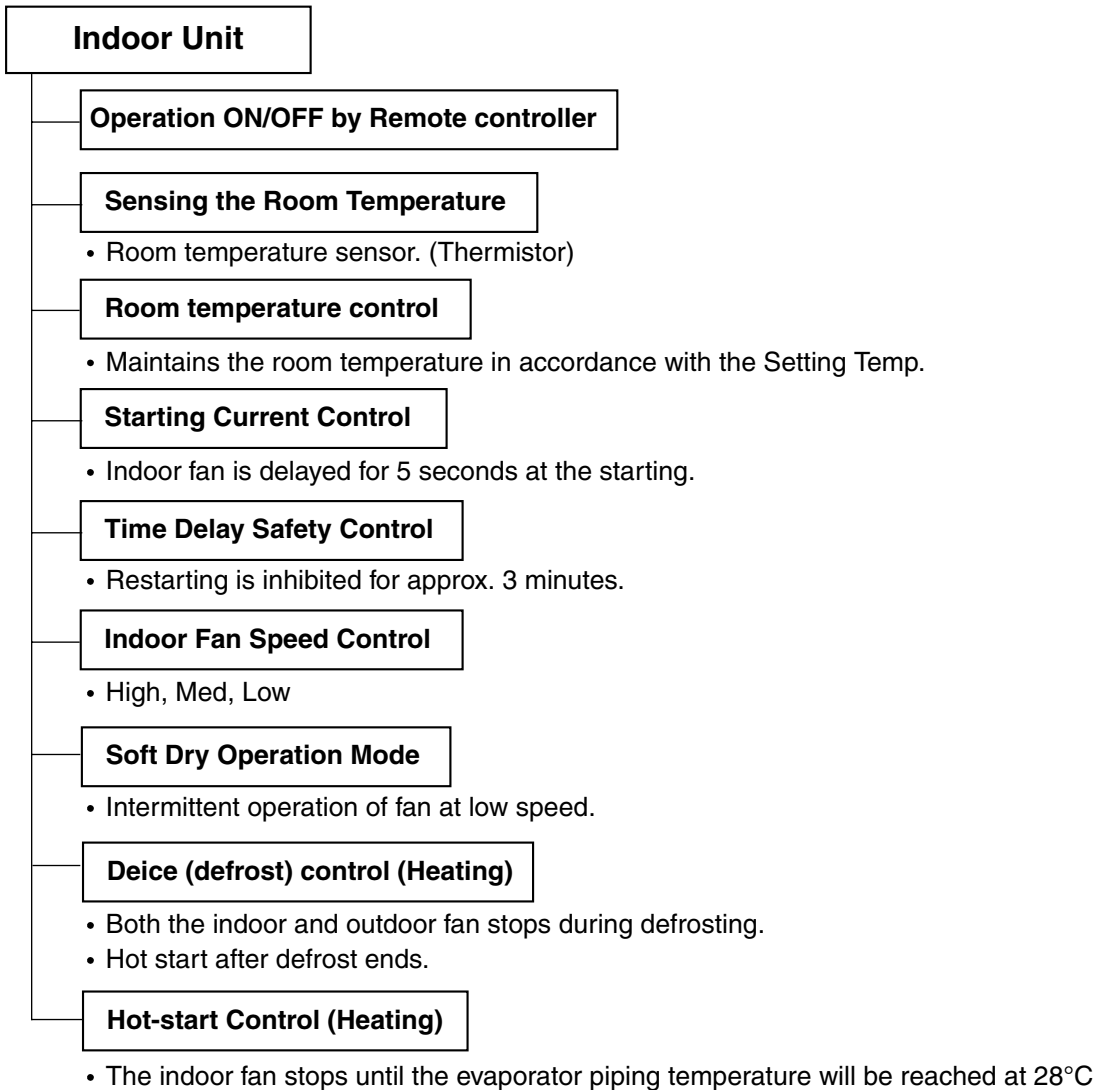

Remote Controller

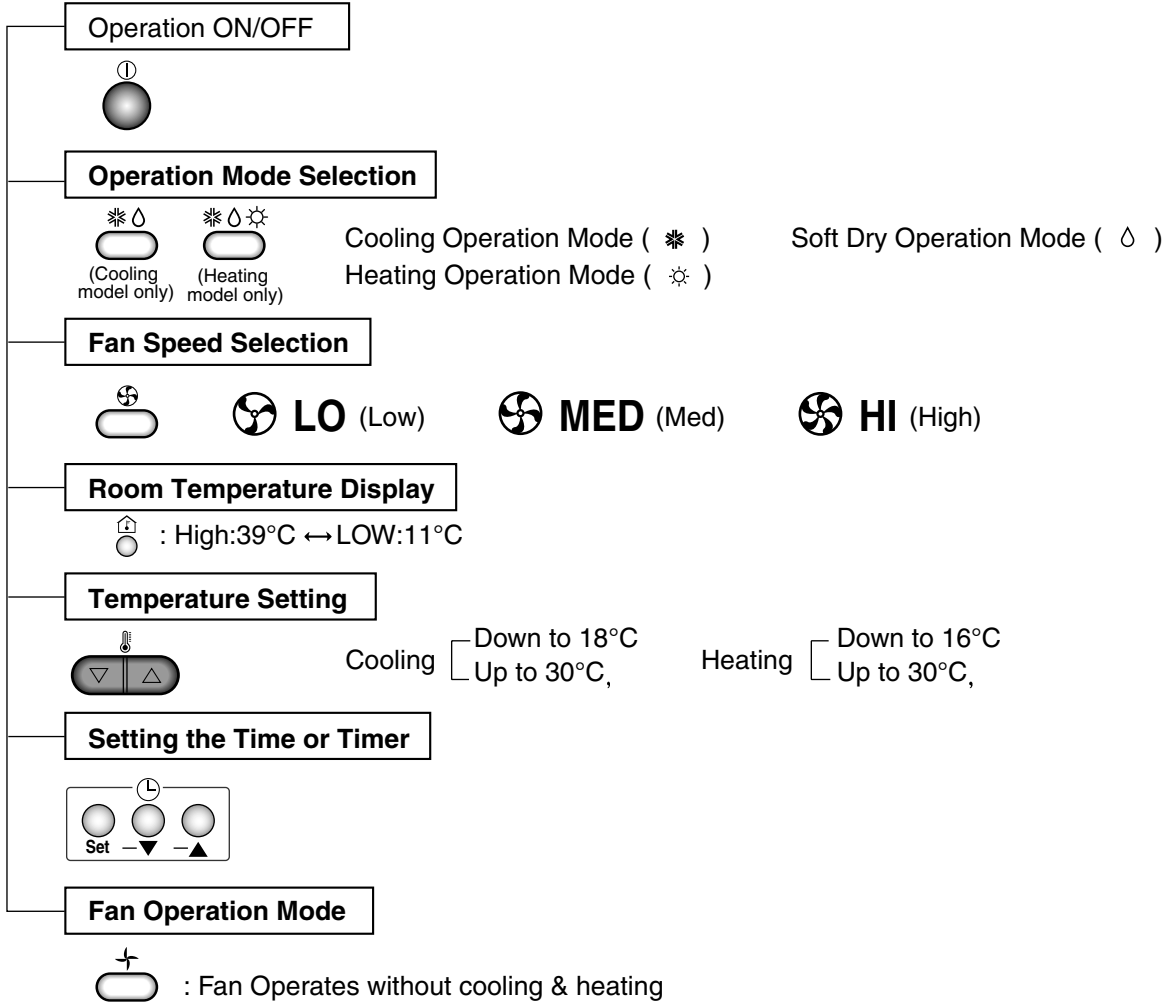

Although the air conditioner is turned off by a power failure, it is restarted automatically after a power resupply.

Product Specifications (Cooling & Heating)

Item		Model Name		LB-F3660HL	LB-F3660CL
		Unit			
Cooling Capacity		Btu/h(kcal/h)		36,000(9,073)	36,000(9,073)
Heating Capacity		Btu/h(kcal/h)		36,000(9,073)	-
Moisture Removal		l/h		5.0	
Power Source		Ø, V, Hz		1, 220-240, 50	
Air Circulation	Indoor	m ³ /min		37	
	Outdoor			58	
Input	Cooling	W	4,600	4,700	
	Heating		4,150	-	
Running Current	Cooling	A	23	23	
	Heating		21.5	-	
E.E.R.		Btu/h-W		7.83	7.66
Dimensions (W × H × D)	Indoor	mm		1,180 x 298 x 600	
	Outdoor			790 x 965 x 320	
Net. Weight	Indoor	kg		46	46
	Outdoor			81	78
Refrigerant (R-22)		g		3.4	3.4
Remocon Type				L.C.D	
Service Valve & Connecting Tube		Liquid		3/8" (9.52)	
		Gas		5/8" (15.88)	
Drain Hose				○	
Connecting Wire				0.75mm ² ↑	
Main Power Cable				5.5mm ² ↑	
Time Delay Safety Function				○	
Soft Dry				○	
Fan Speed (Indoor)				3 (Hi, Med, Low)	
Timer				24Hrs	
Self-Diagnosis				○	

Dimensions

■ Model:LB-F3660HL/CL

(1) Indoor Unit

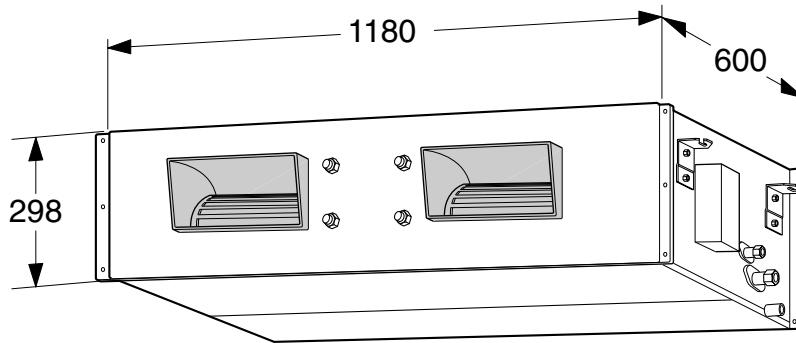

(2) Outdoor Unit

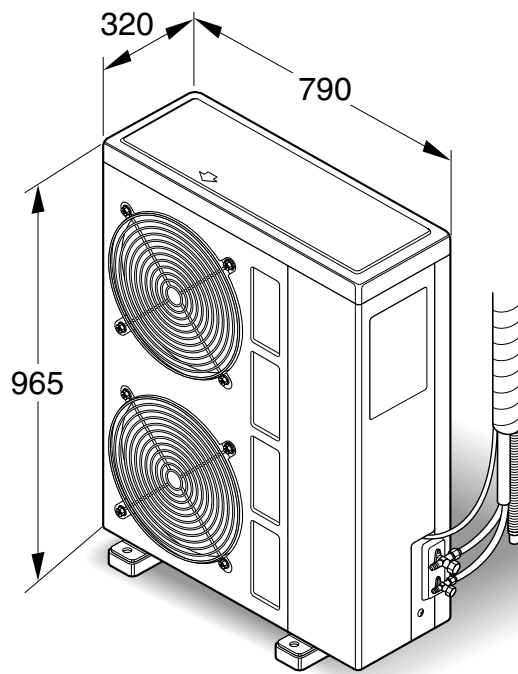

Refrigeration Cycle Diagram

■ LB-F3660HL

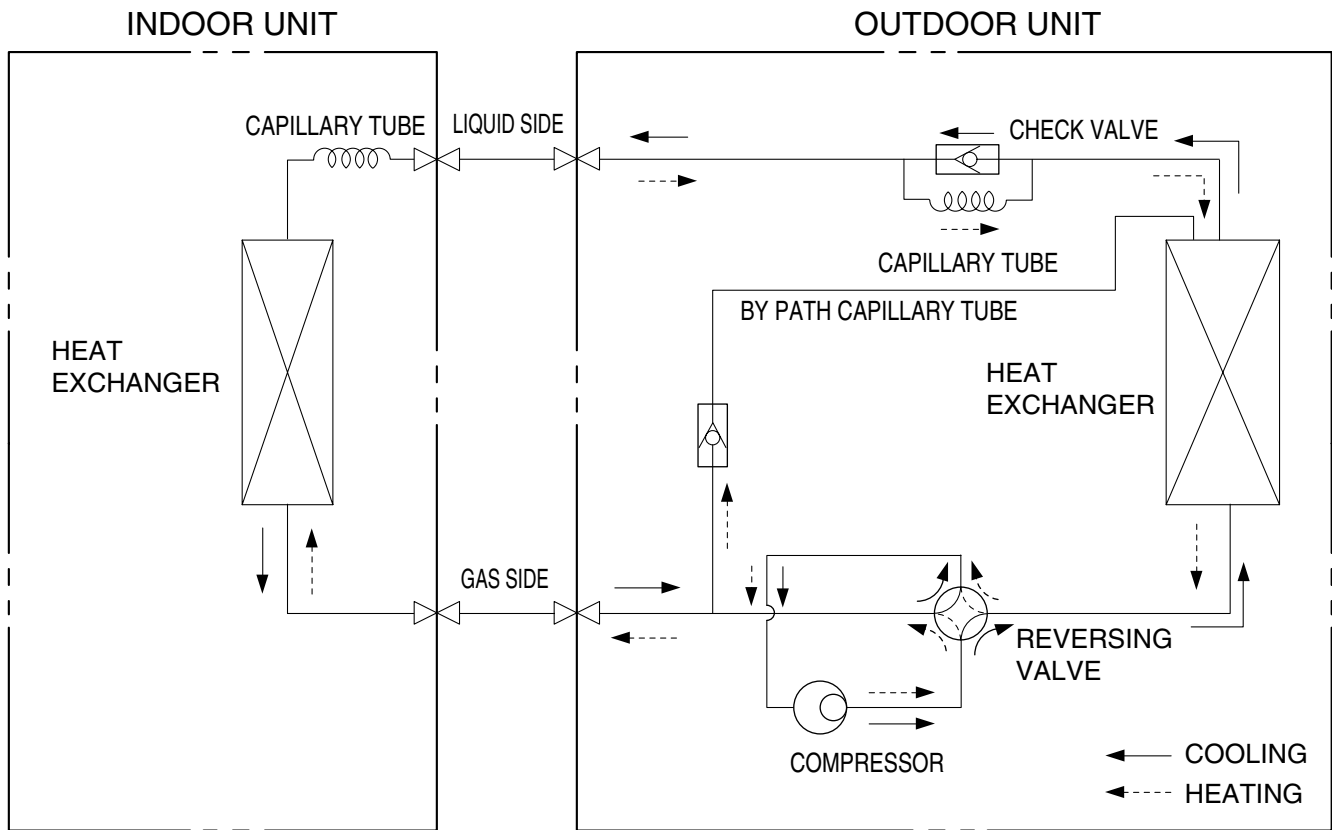

MODEL	Pipe size(Diameter: ø)		Piping length(m)		Elevation(m)	
	Gas	Liquid	Rated	Max.	Rated	Max.
LB-F3660HL	5/8"	3/8"	5	25	5	15

(■ Rated performance for refrigerant line length of: 5m)

For installation over rated distance, 70g of refrigerant should be added for each meter.

ex) When installed at a distance of 15m, 700g of refrigerant should be added.

$$(15-5) \times 70g = 700g$$

■ LB-F3660CL

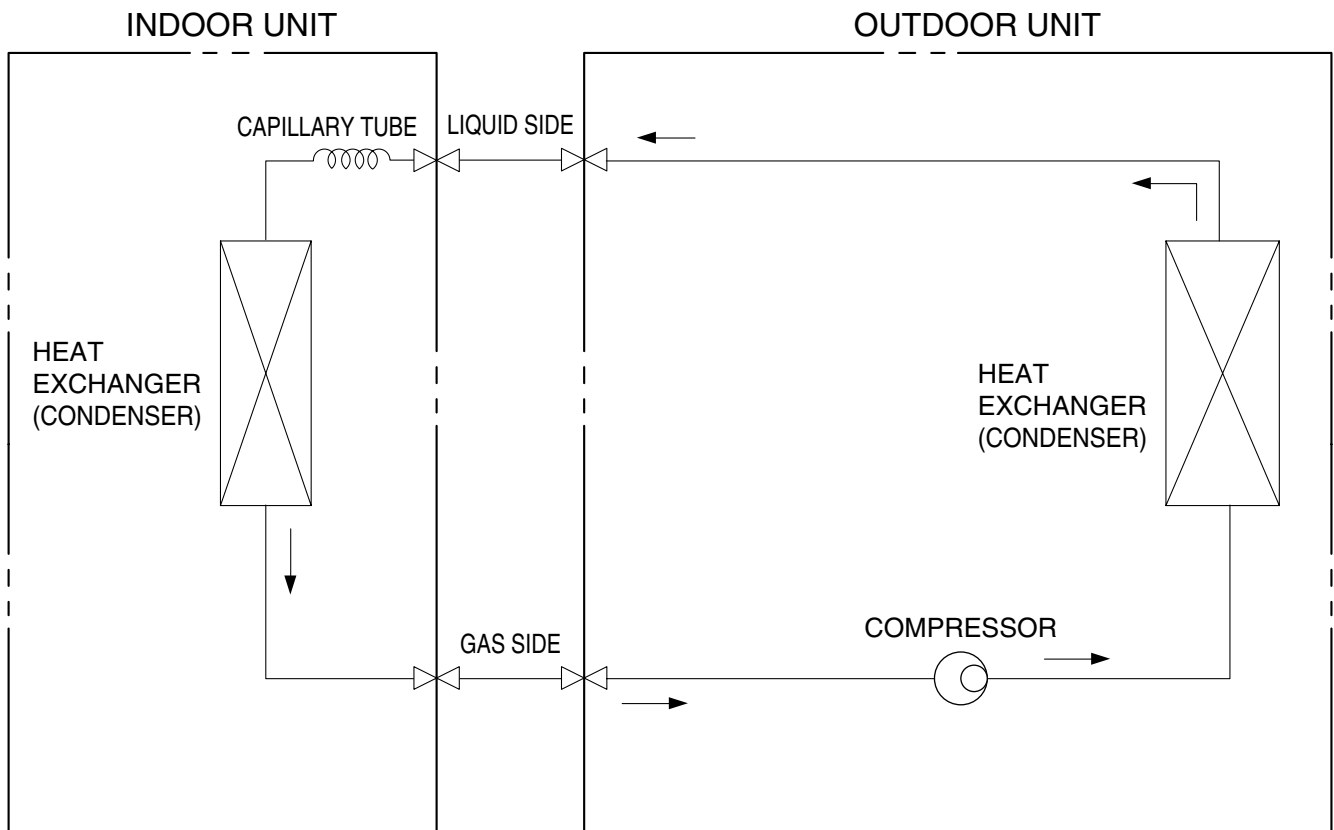

MODEL	Pipe size(Diameter: ϕ)		Piping length(m)		Elevation(m)	
	Gas	Liquid	Rated	Max.	Rated	Max.
LB-F3660CL	5/8"	3/8"	5	25	5	15

(■ Rated performance for refrigerant line length of: 5m)

For installation over rated distance, 70g of refrigerant should be added for each meter.

ex) When installed at a distance of 15m, 700g of refrigerant should be added.

$$(15-5) \times 70g = 700g$$

Wiring Diagram

Model: LB-F3660HL

(1) Indoor Unit

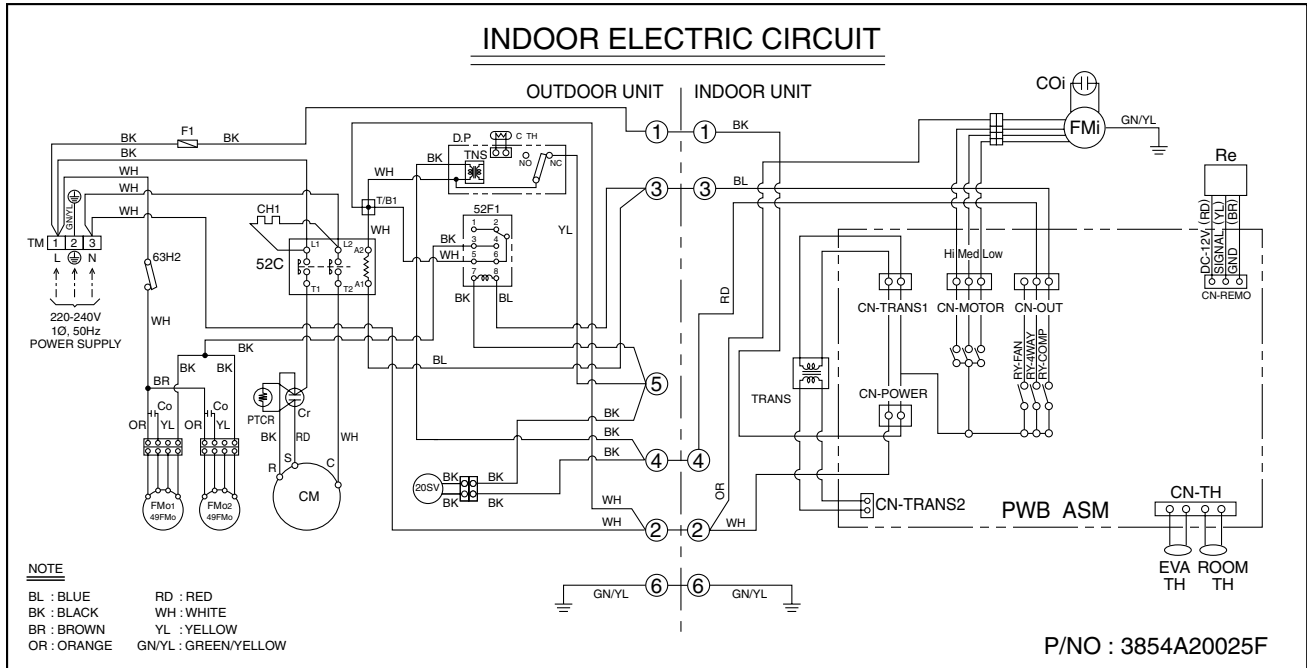

(2) Outdoor Unit

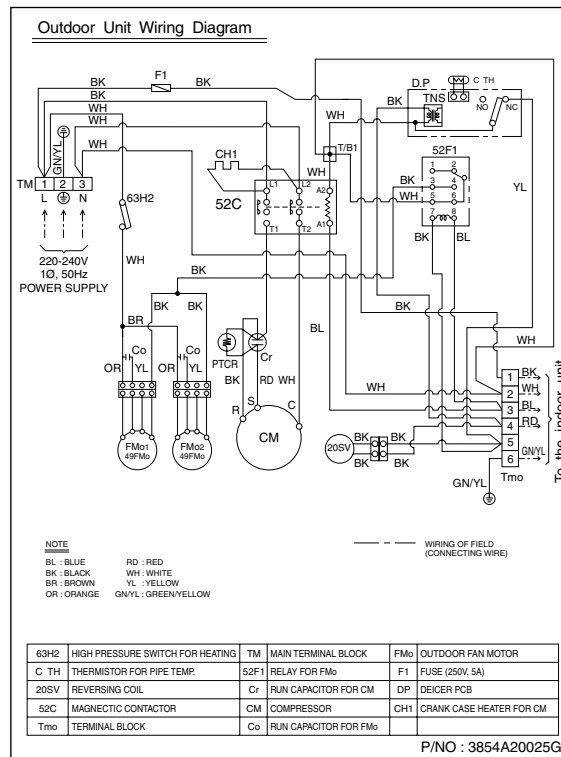

Model: LB-F3660CL

(1) Indoor Unit

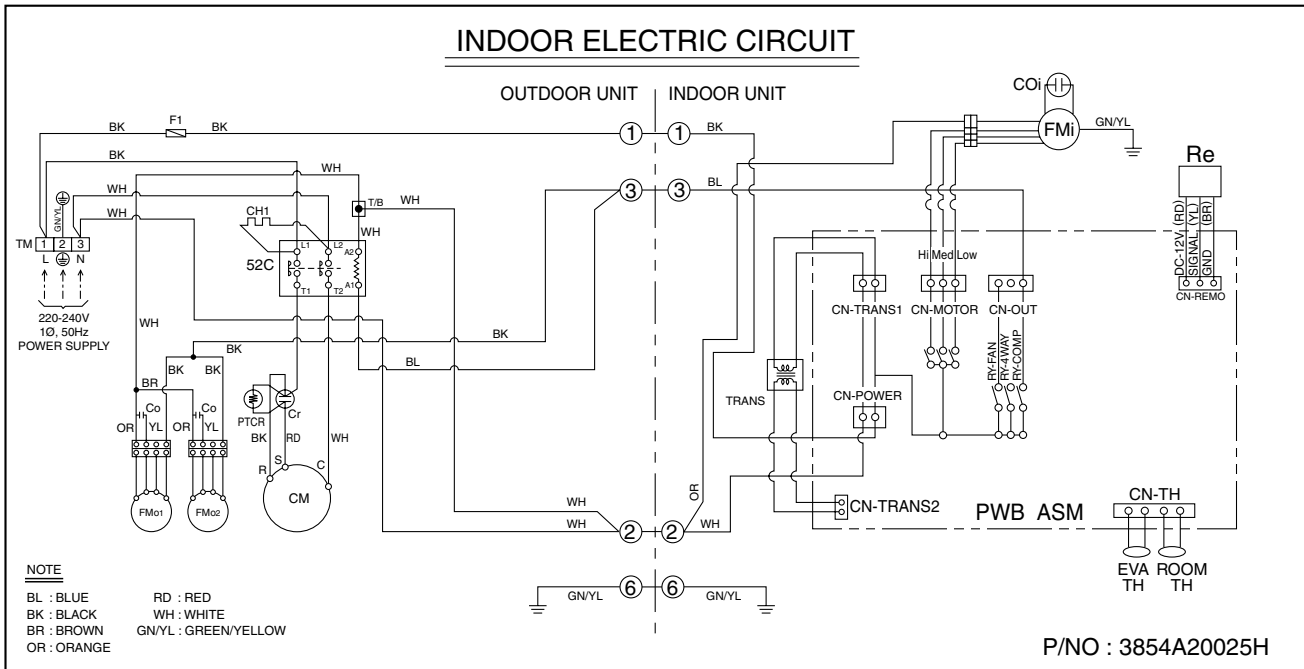

(2) Outdoor Unit

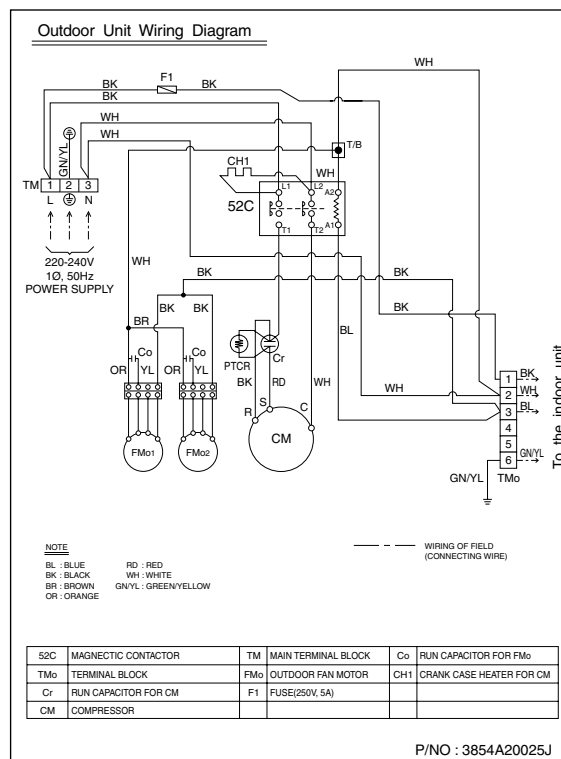

Operation Details

(1) The function of main control

1. Time Delay safety Control

- 3min... The compressor is ceased for 3minutes to balance the pressure in the refrigeration cycle.
(Protection of compressor)
- 30sec... The 4-way valve is ceased for 30sec. to prevent the refrigerant-gas abnormal noise when the Heating operation is OFF or switched to the other operation mode while compress is off.
While compressor is running, it takes 3~5 seconds to switch.

2. Soft-Dry Operation

- The indoor fan speed is automatically set to the low, so the shift of the indoor fan speed is impossible because of already being set to the best speed for Dry Operation by Micom Control.

3. Cooling Mode Operation

- When selecting the Cooling(✳) Mode Operation, the unit will operate according to the setting by the remote controller and the operation diagram is as following

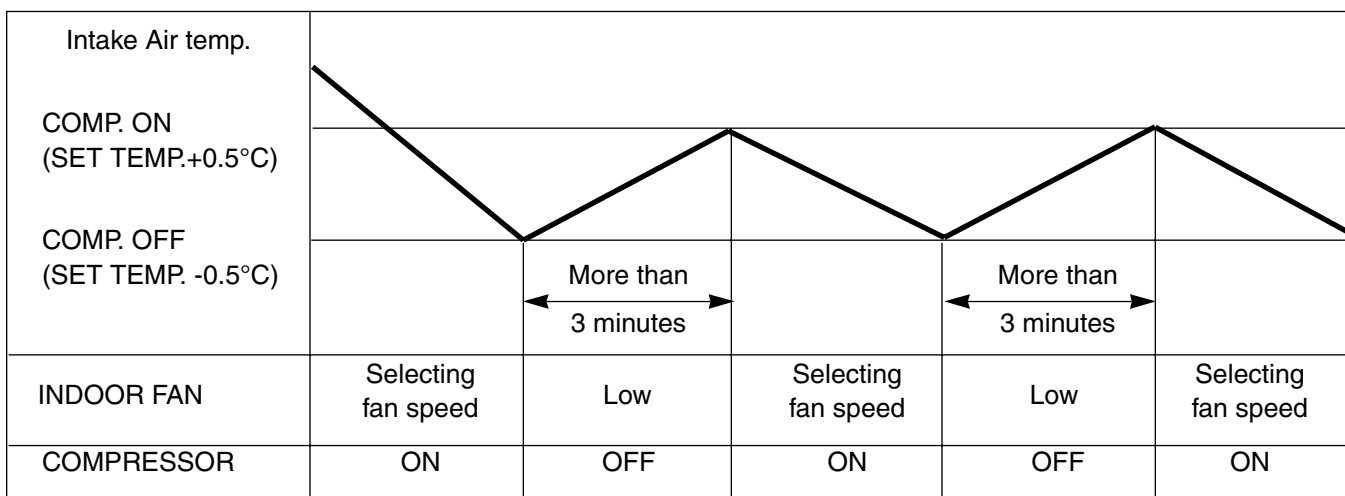

4. Heating Mode Operation (Except Cooling Model)

The unit will operate according to the setting by the remote controller and the operation diagram is shown as following.

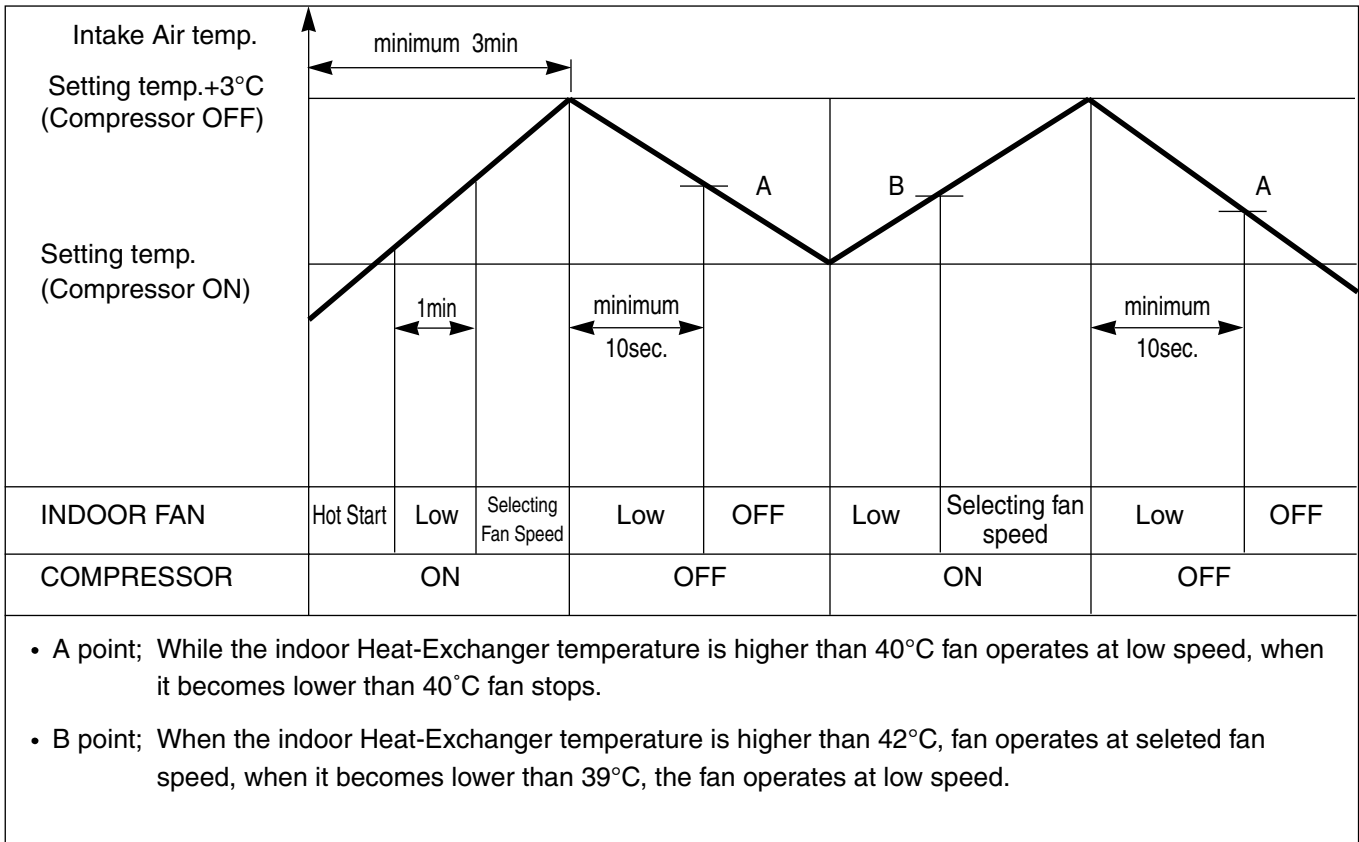

5. Hot-Start Control

- The indoor fan stops until the evaporator piping temperature will be reached to 31°C.
- The operation diagram is as following.

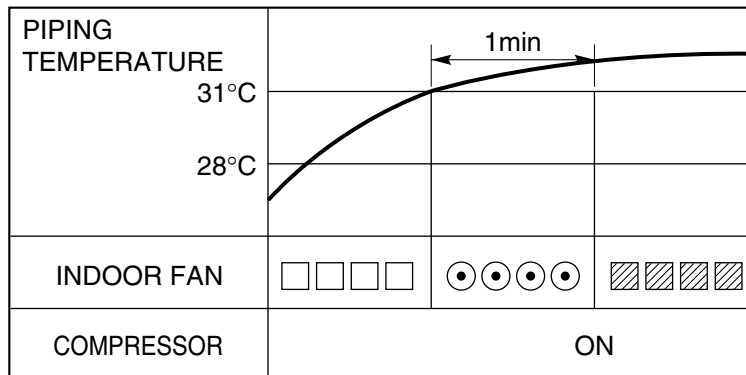

▨ : Selected Fan ● : Low Fan □ : Fan Stop

6. Defrost Control

- Defrost operation is controlled by timer and sensing the outdoor piping temperature.
- The defrost starts only when the outdoor pipe temperature falls below -6°C after 45 minutes passed from starting of heating operation.
- Defrost ends after 10 minutes passed from starting of defrost operation or when the outdoor pipe temperature rises over 12°C even if before 10 minutes.

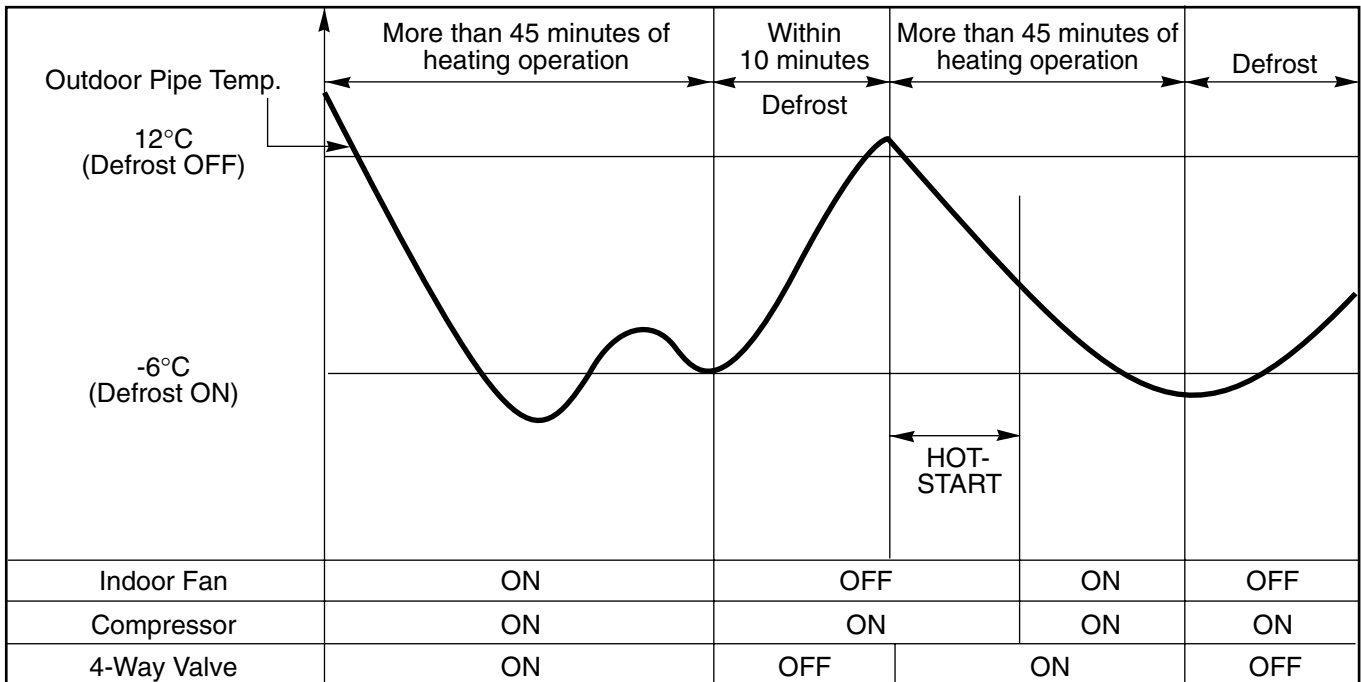

7. Auto Restarting Operation

- When the power is restored after a sudden power failure while in appliance operation, the mode before the power failure is kept on the memory and the appliance should be on the automatically operates in the mode on the memory.
- Operation Mode that is kept on the memory
 - State of Operation ON/OFF
 - Operation Mode/Setting Temp/Selected Airflow Speed
- If no input by the remote controller within 7 hr after the appliance operates by the Auto Restarting operation, the appliance is forced to stop at the moment of 7-hr elapse.

8. Self-Diagnosis Function

- 'CHECK' will flash in the remote controller display when a problem occurs. Then please contact your dealer.
- Correct the accident point as shown in the table below before restarting operation.
- During the normal operation 'CHECK' won't be displayed in the remote controller.

Remote controller LCD	Accident Point
F1	Indoor temperature thermistor error
F2	Indoor piping thermistor error
F3	Indoor/Outdoor unit communication error

Installation of Indoor, Outdoor Unit

1. Selection of the best location

1) Indoor unit

Select location

Install the air conditioner in the location that satisfies the following conditions.

- The place shall easily bear a load exceeding four times the indoor unit's weight.
- The place shall be able to inspect the unit as the figure.
- The place where the unit shall be leveled.
- The place shall allow easy water drainage.(Suitable dimension "H" is necessary to get a slope to drain as figure.)
- The place shall easily connect with the outdoor unit.
- The place where the unit is not affected by an electrical noise.
- The place where air circulation in the room will be good .
- There should not be any heat source or steam near the unit.

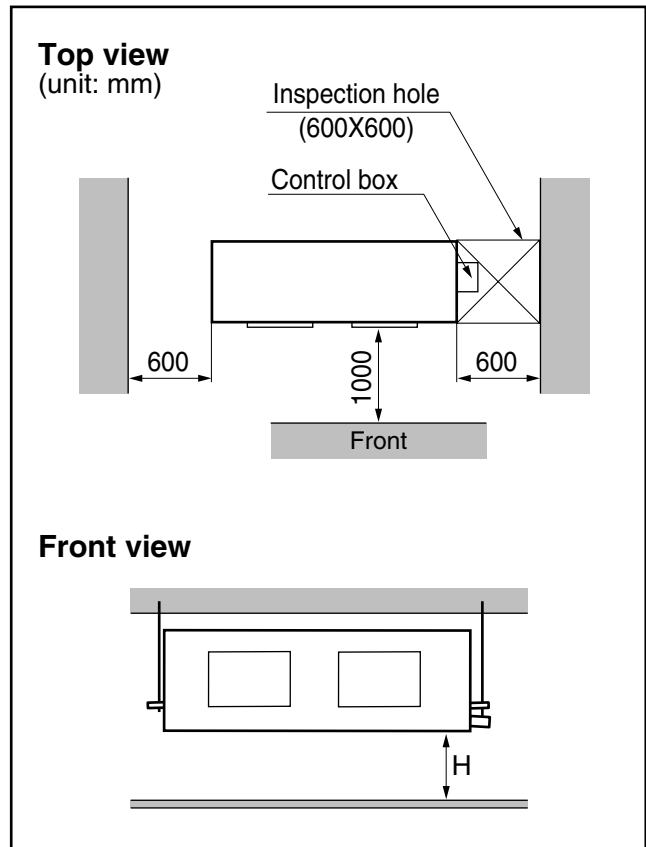

2) Outdoor unit

- If an awning is built over the unit to prevent direct sunlight or rain exposure, be careful that heat radiation from the condenser is not restricted.
- There should not be any animals or plants which could be affected by hot air discharged.
- Ensure the spaces indicated by arrows from the wall, ceiling, fence or other obstacles.

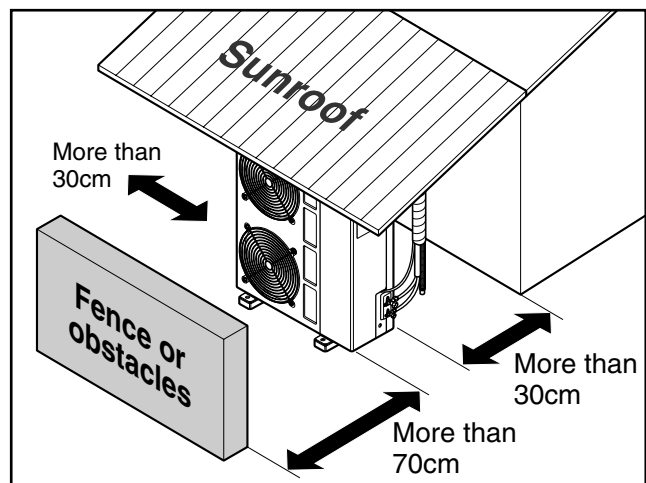

3) Piping length and the elevation

MODEL	Pipe Size (Diameter: Ø)		Length A(m)		Elevation B(m)		* Additional refrigerant (g/m)
	Gas	Liquid	Standard	Max.	Standard	Max.	
36K BTU	5/8"	3/8"	5	25	5	15	70

- If 36K Model is installed at a distance of 15m, 700g of refrigerant should be added $(15-5) \times 70g = 700g$.
- Capacity is based on standard length and maximum allowance length is on the basis of reliability.

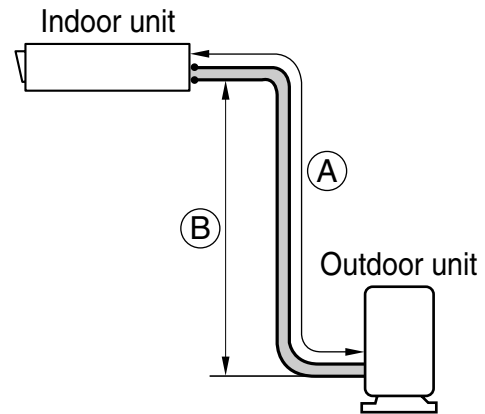

NOTE:

- Thoroughly study the following installation locations:

1. In such places as restaurants and kitchens, considerable amount of oil steam and flour adhere to the fan, the fin of the heat exchanger, resulting in heat exchange reduction, spraying, dispersing of water drops, etc.
In these cases, take the following actions:
 - Make sure that the ventilation fan for smoke-collecting hood on a cooking table has sufficient capacity so that it draws oily steam which should not flow into the suction of the air conditioner.
 - Make enough distance from a cooking room to install the air conditioner in such a place where it may not suck in oil steam.
2. Avoid installing air conditioner in such circumstances where cutting oil mist or iron powder is in suspension in factories, etc.
3. Avoid places where inflammable gas is generated, flows in, is stored or vented.
4. Avoid places where sulfurous acid gas or corrosive gas is generated.
5. Avoid places near high frequency generators.

2. Ceiling dimensions and hanging bolt location

■ Installation of Unit

Install the unit above the ceiling correctly.

CASE 1

POSITION OF SUSPENSION BOLT

- Apply a joint-canvas between the unit and duct to absorb unnecessary vibration.
- Apply a filter Accessory at air return hole.

(Unit:mm)

Dimension Capacity	A	B	C	D	E	F	(G)	H	I
36K BTU	1242	1180	492	54	600	30	87	830	186

- Install the unit leaning to a drainage hole side as a figure for easy water drainage.

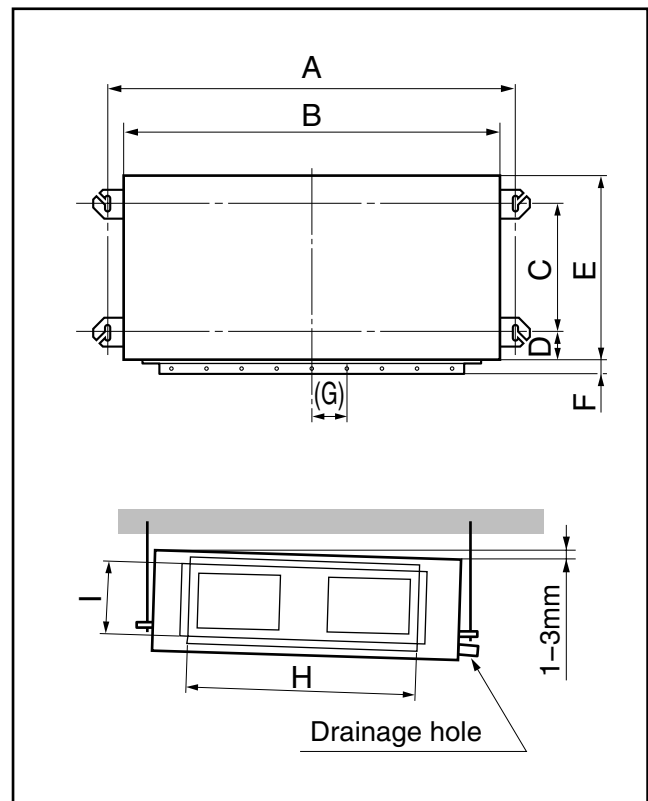

CASE 2

POSITION OF CONSOLE BOLT

- A place where the unit will be leveled and that can support the weight of the unit.
- A place where the unit can withstand its vibration.
- A place where service can be easily performed.

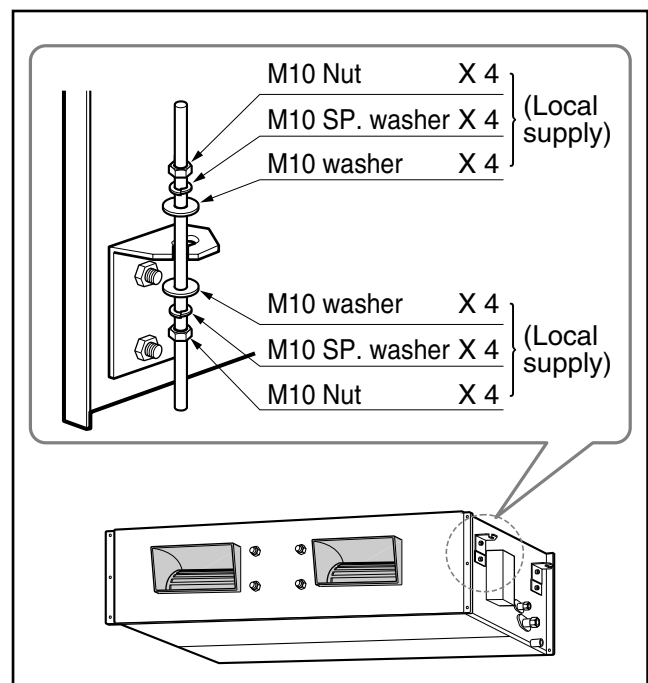

3. The Indoor Unit Installation

- Select and mark the position for fixing bolts.
- Drill the hole for set anchor on the face of ceiling.

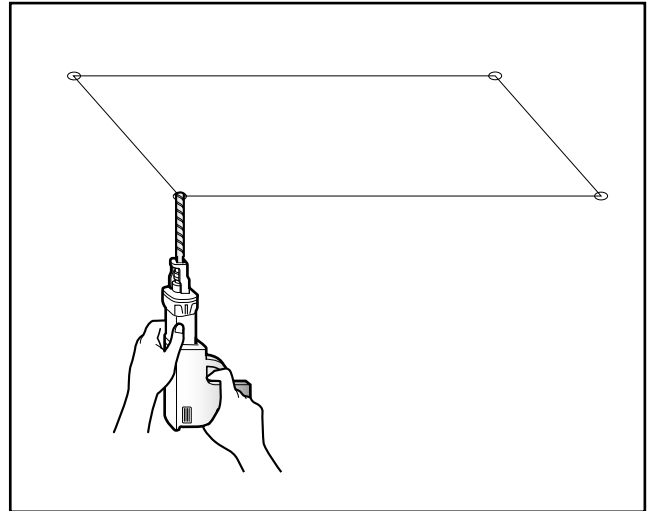

- Insert the set anchor and washer onto the suspension bolts for locking the suspension bolts on the ceiling.
- Mount the suspension bolts to the set anchor firmly.
- Secure the installation plates onto the suspension bolts (adjust level roughly) using nuts, washers and spring washers.

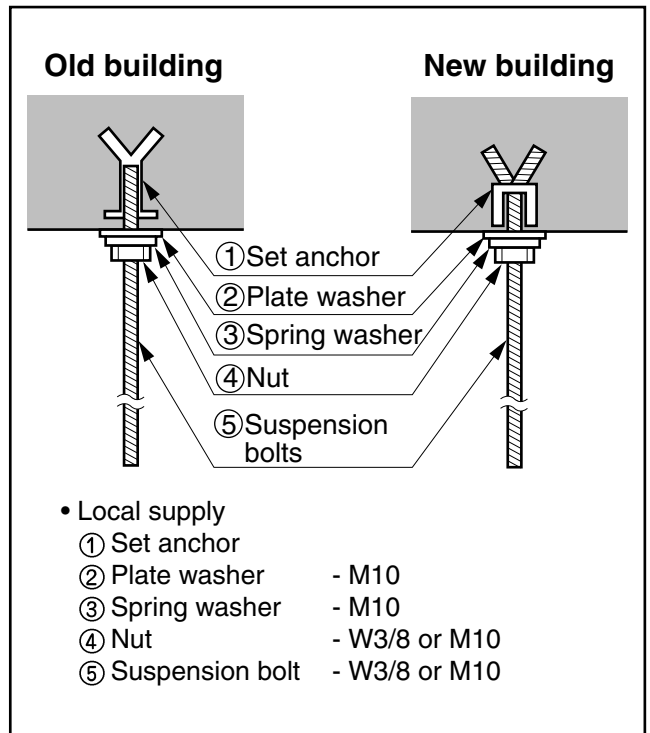

CAUTION

Tighten the nut and bolt to prevent unit falling

4. Remote Controller Installation

- Although the room temperature sensor is in the indoor unit, the remote control box should be installed in such places away from direct sunlight and high humidity.

Installation of the remote control box

- Select places that are not splashed with water.
- Select control position after receiving customer approval.
- The room temperature sensor of the thermostat for temperature control is built in the indoor unit.
- This remote controller equipped with liquid crystal display. If this position is higher or lower, display is difficult to see. (The standard height is 1.2 ~ 1.5m high)

Routing of the remote control cord

- Keep the remote control cord away from the refrigerant piping and the drain piping.
- To protect the remote control cord from electrical noise, place the cord at least 5cm away from other power cables (audio equipment, television set, etc.)
- If the remote control cord is secured to a wall, provide a trap at the top of the cord to prevent water droplets from running.

REMOTE CONTROL BOX INSTALLATION

DISASSEMBLING

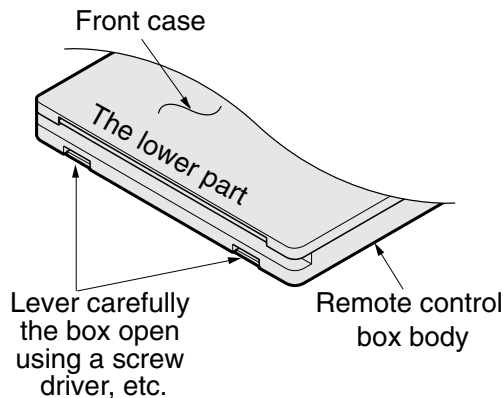

- Separate the under plate from Remote control box.

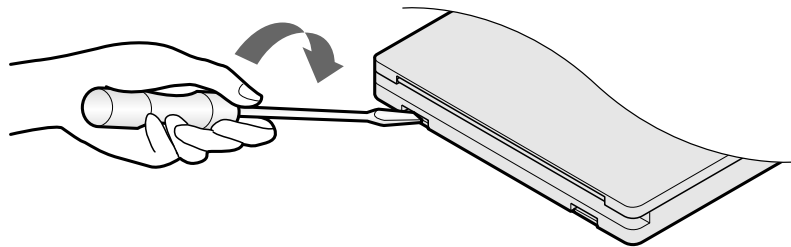

- Fix the cord clamps on the wall by $\varnothing 3$ tapping screws (accessory).
- Fix the remote control cord.

- Fix the under plate on the wall

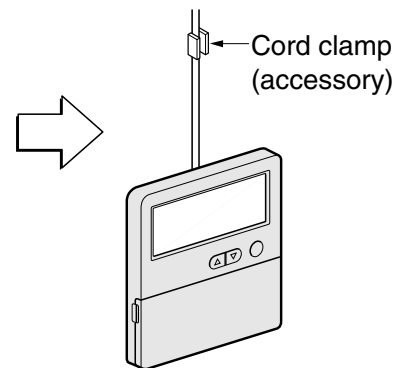
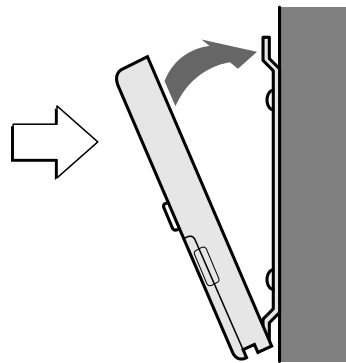
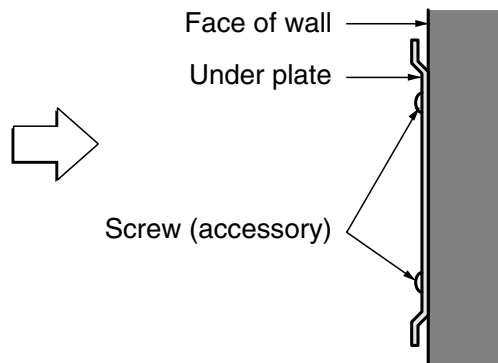

ELECTRICAL WIRING

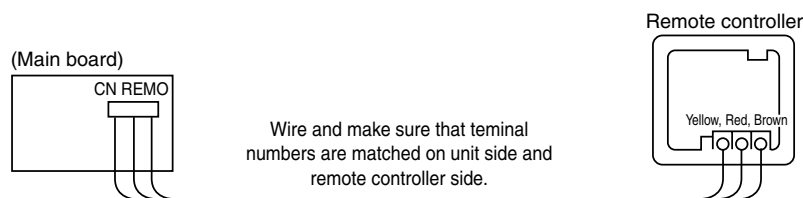

Wire and make sure that terminal numbers are matched on unit side and remote controller side.

The maximum length of the cord is 100m.
If the length of the cord exceeds 50m,
use a wire size greater than 0.5mm².

5. Connecting Cables between Indoor Unit and Outdoor Unit

1) Connecting cables to the Indoor Unit

- Connect the wires to the terminals on the control board individually according to the outdoor unit connection.
 - Ensure that the color of the wires of outdoor unit and the terminal No. are the same as those of indoor unit respectively

■ 36K BTU

- Cooling and Heating Type

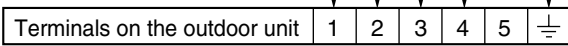
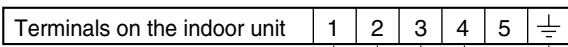

- Cooling only Type

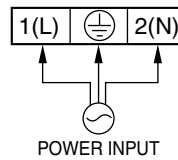
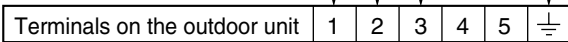
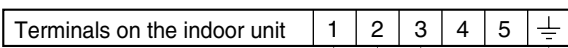

CAUTION

The power cord connected to the outdoor unit should be complied with the following specifications (Rubber insulation, type H05RN-F approved by HAR or SAA).

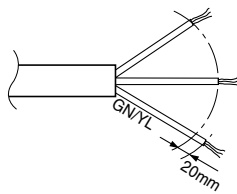

NORMAL
CROSS-SECTIONAL
AREA 5.5mm²

The connecting cable connected to the indoor and outdoor unit should be complied with the following specifications (Rubber insulation, type H05RN-F approved by HAR or SAA).

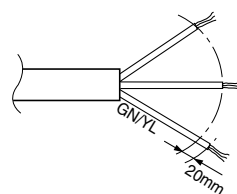

NORMAL
CROSS-SECTIONAL
AREA 0.75mm²

If the supply cord is damaged, it must be replaced by a special cord or assembly available from the manufacturer of its service agent.

⚠ WARNING

Make sure that the screws of the terminal are free from looseness.

2) Clamping of cables

- 1) Arrange 2 power cables on the control panel.
- 2) First, fasten the steel clamp with a screw to the inner boss of control panel.
- 3) For the cooling model, fix the other side of the clamp with a screw strongly.
For the heat pump model, put the 0.75mm² cable(thinner cable) on the clamp and tighten it with a plastic clamp to the other boss of the control panel.
- 4) In Australia, the length of power supply cord measured from the entry of the power supply cord to the middle of live pin on the power plug should be over 1.8m.

ELECTRICAL WIRING

Perform the electrical wiring work according to the electrical wiring connection.

- All wiring must comply with local requirements.
- Select a power source that is capable of supplying the current required by the air conditioner.
- Use a recognized circuit breaker 35A between the power source and the unit. A disconnection device to adequately disconnect all supply lines must be fitted.

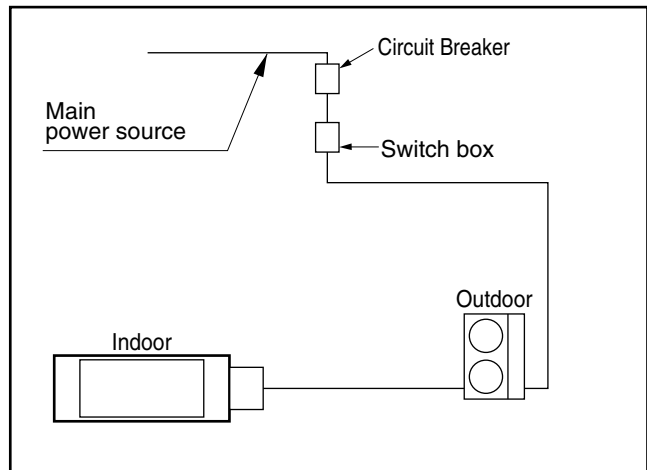

WIRING CONNECTION

INDOOR UNIT

- Remove the control box cover for electrical connection between the indoor and outdoor unit. (Remove two screws ①.)
- Use the cord clumper to fix the cord.

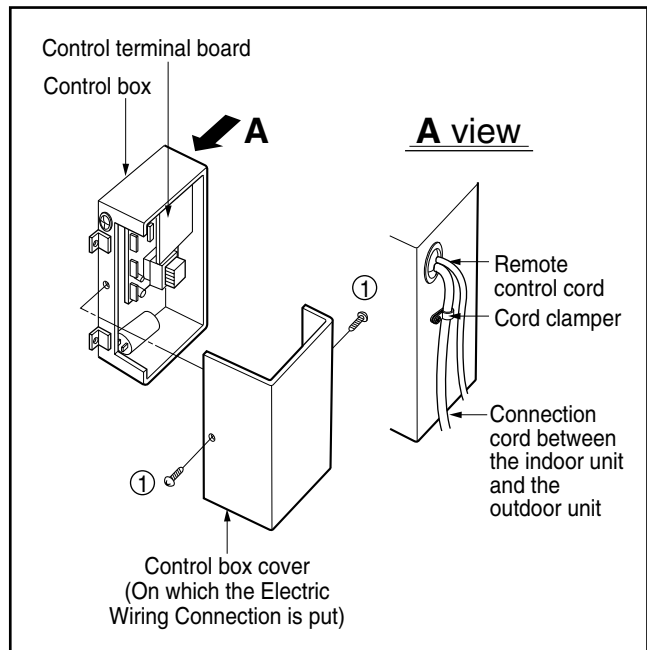

OUTDOOR UNIT

- Remove the control cover for wiring connection.
- Use the cord clumper to fix the cord.
- Earthing work
Connect the cable of diameter 1.6mm² or more to the earthing terminal provided in the control box and do earthing.

※ **Please check !!**

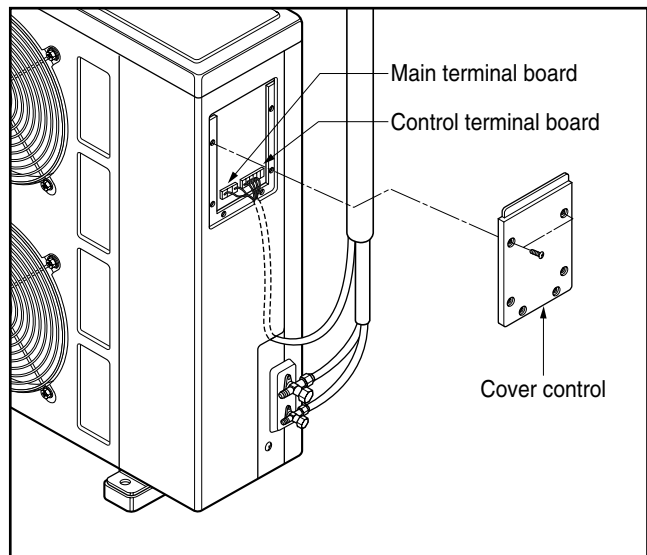

6. Connecting Pipes to the Indoor Unit

• Preparation of Piping

Main cause of gas leakage is defect in flaring work.
Carry out correct flaring work in the following procedure.

1) Cut the pipes and the cable.

- Use the accessory piping kit or the pipes purchased locally.
- Measure the distance between the indoor and the outdoor unit.
- Cut the pipes a little longer than measured distance.
- Cut the cable 1.5m longer than the pipe length.

2) Burrs removal

- Completely remove all burrs from the cut cross section of pipe/tube.
- Put the end of the copper tube/pipe to downward direction as you remove burrs in order to avoid to let burrs drop in the tubing.

3) Putting nut on

- Remove flare nuts attached to indoor and outdoor units, than put them on pipe/tube having completed burr removal.
(Not possible to put them on after flaring work)

4) Flaring work

- Carry out flaring work using flaring tool as shown below.

Outside diameter		A
mm	inch	mm
Ø9.52	3/8	0.5~0.8
Ø15.88	5/8	0.8~1.0

Firmly hold copper tube in a bar(or die) as indicated dimension in the table above.

5) Check

- Compare the flared work with figure below.
- If flare is noted to be defective, cut off the flared section and do flaring work again.

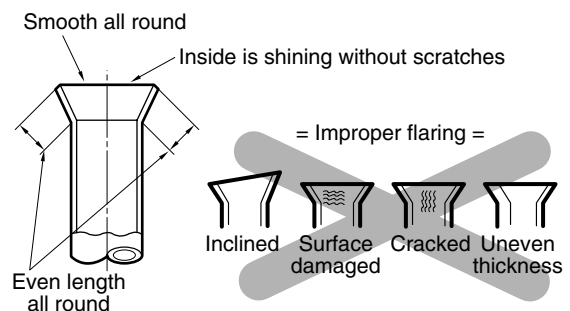
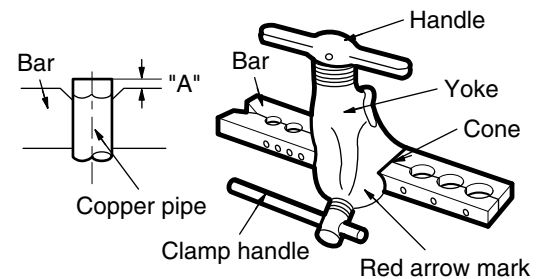
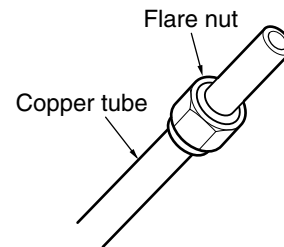
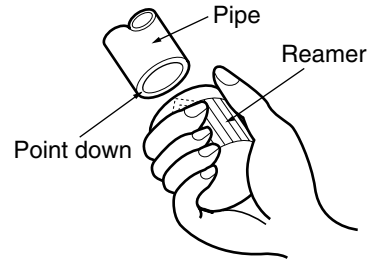
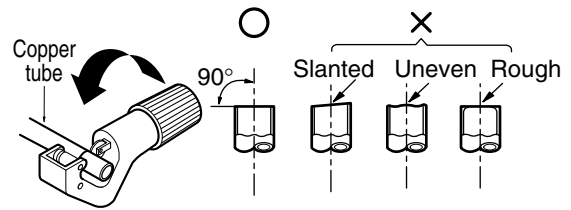

Piping Connection

1. Form the piping according to its routing. Avoid bending and bending back the same piping point more than three times. (This will result in hardening the pipe.)
2. After deforming the piping, align centers of the union fitting of the indoor unit and the piping, and tighten them firmly with wrenches.
3. Connect pipe to the service valve or ball valve which is located below the outdoor unit.
4. After completing the piping connection, be sure to check if there is gas leakage in indoor and outdoor connection.

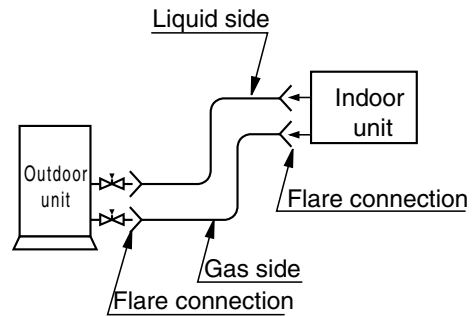

Vacuum drying

After completing the piping connection, execute vacuum drying for the connecting piping and the indoor unit.

The vacuum drying must be carried out using the service ports of both the liquid and gas side valves.

Model	Liquid side piping	Gas side piping
36K BTU	Ø 9.52mm	Ø15.88mm

CAUTION

Use two wrenches and tighten with regular torque.

Flare nut fastening torque			
Ø6.35mm	1.8kg·mm	Ø12.7mm	5.5kg·mm
Ø9.52mm	4.0kg·mm	Ø15.88mm	6.6kg·mm

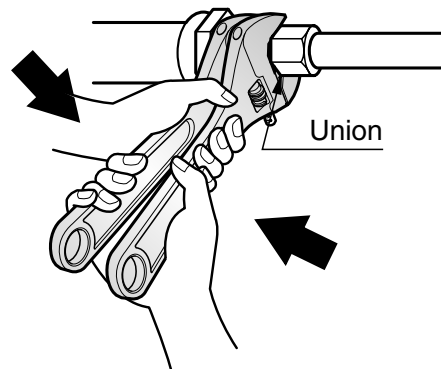

CAUTION

1. **Install declination** of the indoor unit is very **important for the drain** of the duct type air conditioner.
2. Minimum thickness of the insulation for the connecting pipe shall be 5mm.

Front of view

- The unit must be horizontal or declined to the drain hose connected when finished installation.

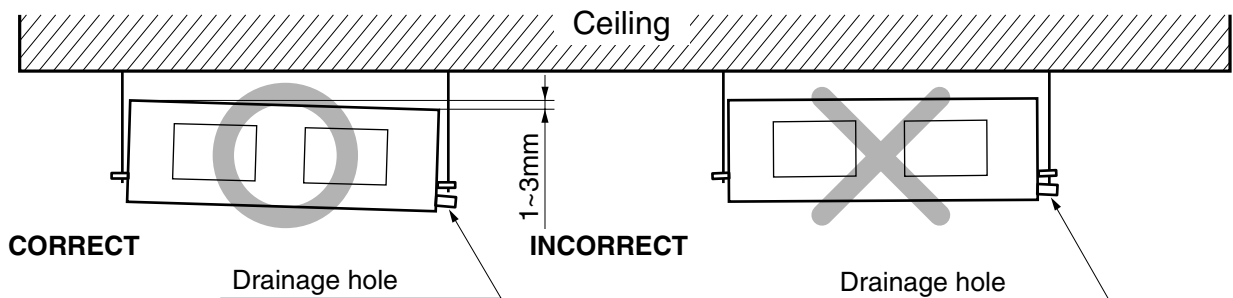

CAUTION FOR GRADIENT OF UNIT AND DRAIN PIPING

Lay the drain hose with a downward inclination so water will drain out.

- Always lay the drain with downward inclination (1/50 to 1/100). Prevent any upward flow or reverse flow in any part.
- 5mm or thicker formed thermal insulator shall always be provided for the drain pipe.

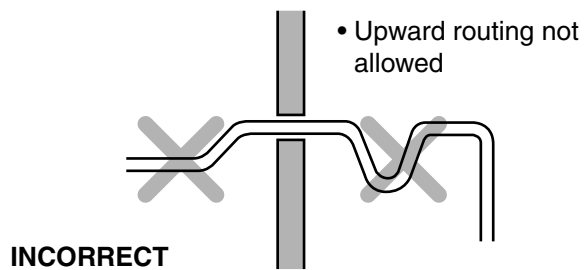
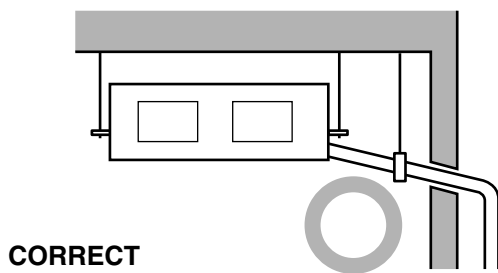
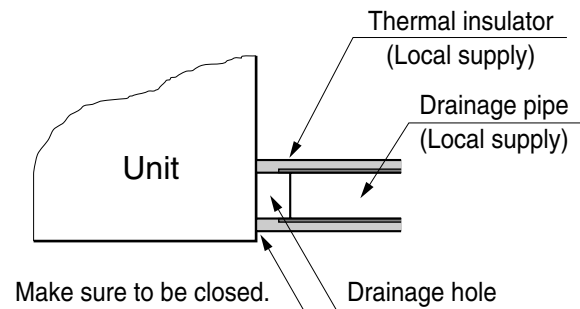

- Drill the piping hole with 70mm dia, hole core drill.
- Piping hole should be slightly slant to the outdoor side.

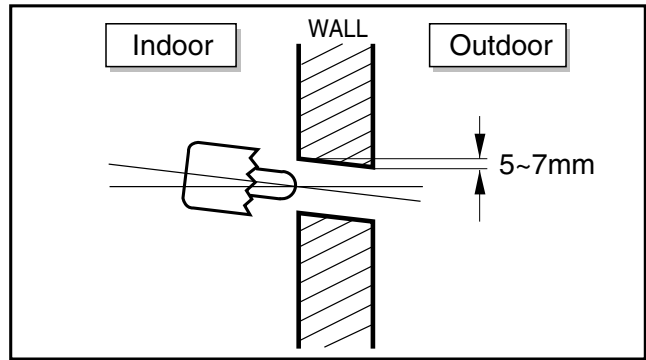

INSULATION, OTHERS

Insulate the joint and tubes completely.

THERMAL INSULATION

All thermal insulation must comply with local requirement.

INDOOR UNIT

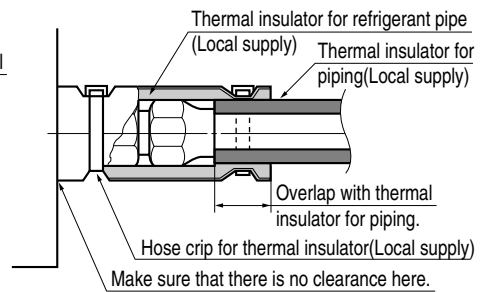
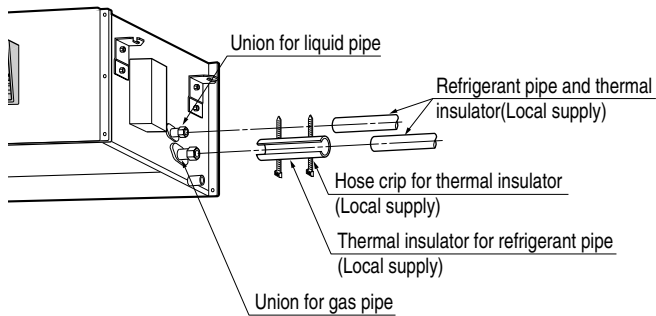

REFRIGERANT PIPE

- Insulate and tape both the gas piping and liquid piping.

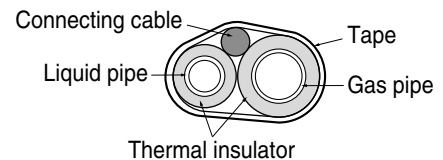

FORM THE PIPINGS

1. Wrap the connecting portion of indoor unit with the Insulation material and secure it with two Plastic Bands. (for the right pipings)

- If you want to connect an additional drain hose, the end of the drain-outlet should keep distance from the ground. (Do not dip it into water, and fix it on the wall to avoid swinging in the wind.)

In case of the Outdoor unit being installed below position of the Indoor unit.

2. Tape the Pplings, drain hose and Connecting Cable from bottom to top.

3. Form the pipings gathered by taping along the exterior wall and fix it onto the wall by saddle or equivalent.

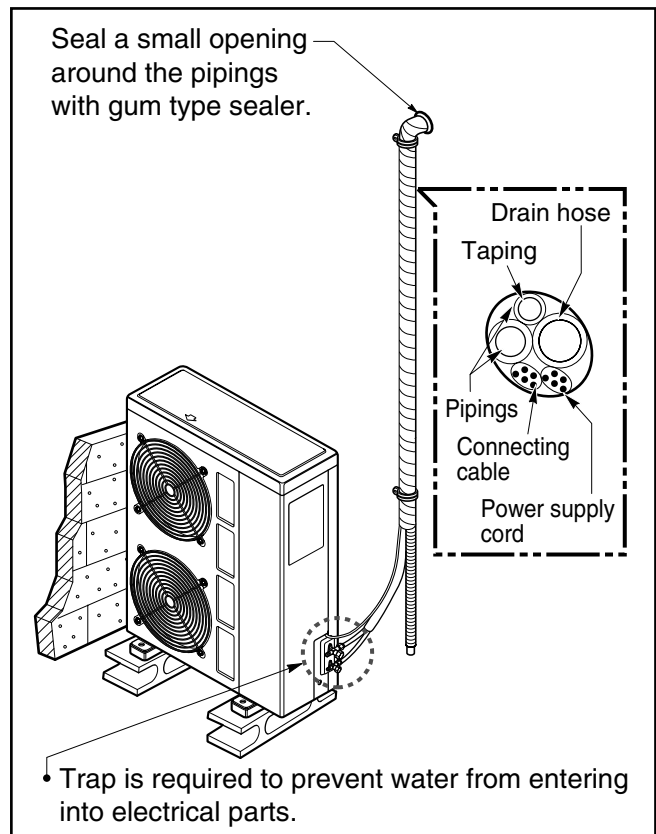

Test running

1) PRECAUTIONS IN TEST RUN

- The initial power supply must provide at least 90% of the rated voltage. Otherwise, the air conditioner should not be operated.

① For test run, carry out the cooling operation firstly even during heating season. If heating operation is carried out firstly, it leads to the trouble of compressor. Then attention must be paid.

Caution

② Carry out the test run more than 5 minutes without fail.
(Test run will be cancelled 18 minutes later automatically)

- The test run is started by pressing the room temperature checking button and down timer button for 3 seconds at the same time.
- To cancel the test run, press any button.

CHECK THE FOLLOWING ITEMS WHEN INSTALLATION IS COMPLETE

- After completing work, be sure to measure and record trial run properties, and store measured data, etc.
- Measuring items are room temperature, outside temperature, suction temperature, blow out temperature, wind velocity, wind volume, voltage, current, presence of abnormal vibration and noise, operating pressure, piping temperature, compressive pressure.
- As to the structure and appearance, check following items.

<input type="checkbox"/> Is the circulation of air adequate?	<input type="checkbox"/> Is the remote controller switch operated?
<input type="checkbox"/> Is the draining smooth?	<input type="checkbox"/> Is there any faulty wiring?
<input type="checkbox"/> Is the heat insulation complete (refrigerant and drain piping)?	<input type="checkbox"/> Are not terminal screws loosened?
<input type="checkbox"/> Is there any leakage of refrigerant?	

M4...118N·cm{12kgf·cm}

M5...196N·cm{20kgf·cm}

M6...245N·cm{25kgf·cm}

M8...588N·cm{60kgf·cm}

2) Connection of power supply

- 1. Connect the power supply cord to the independent power supply.**
 - Circuit breaker is required.
- 2. Operate the unit for fifteen minutes or more.**

3) Evaluation of the performance

1. Measure the temperature of the intake and discharge air.
2. Ensure the difference between the intake temperature and the discharge one is more than 8°C (Cooling) or reversely (Heating).

CAUTION

After the confirmation of the above conditions, prepare the wiring as follows:

- 1) Never fail to have an individual power specialized for the air conditioner. As for the method of wiring, be guided by the circuit diagram pasted on the inside of control box cover.**
- 2) Provide a circuit breaker switch between power source and the unit.**
- 3) The screw which fasten the wiring in the casing of electrical fittings are liable to come loose from vibrations to which the unit is subjected during the course of transportation. Check them and make sure that they are all tightly fastened. (If they are loose, it could give rise to burn-out of the wires.)**
- 4) Specification of power source**
- 5) Confirm that electrical capacity is sufficient.**
- 6) Be sure that the starting voltage is maintained at more than 90 percent of the rated voltage marked on the name plate.**
- 7) Confirm that the cable thickness is as specified in the power sources specification. (Particularly note the relation between cable length and thickness.)**
- 8) Never fail to equip a leakage breaker where it is wet or moist.**
- 9) The following troubles would be caused by voltage drop-down.**
 - Vibration of a magnetic switch, damage on the contact point there of, fuse breaking, disturbance to the normal function of a overload protection device.
 - Proper starting power is not given to the compressor.

HAND OVER

Teach the customer the operation and maintenance procedures, using the operation manual (air filter cleaning, temperature control, etc.).

3-way Valve

1. Pump down

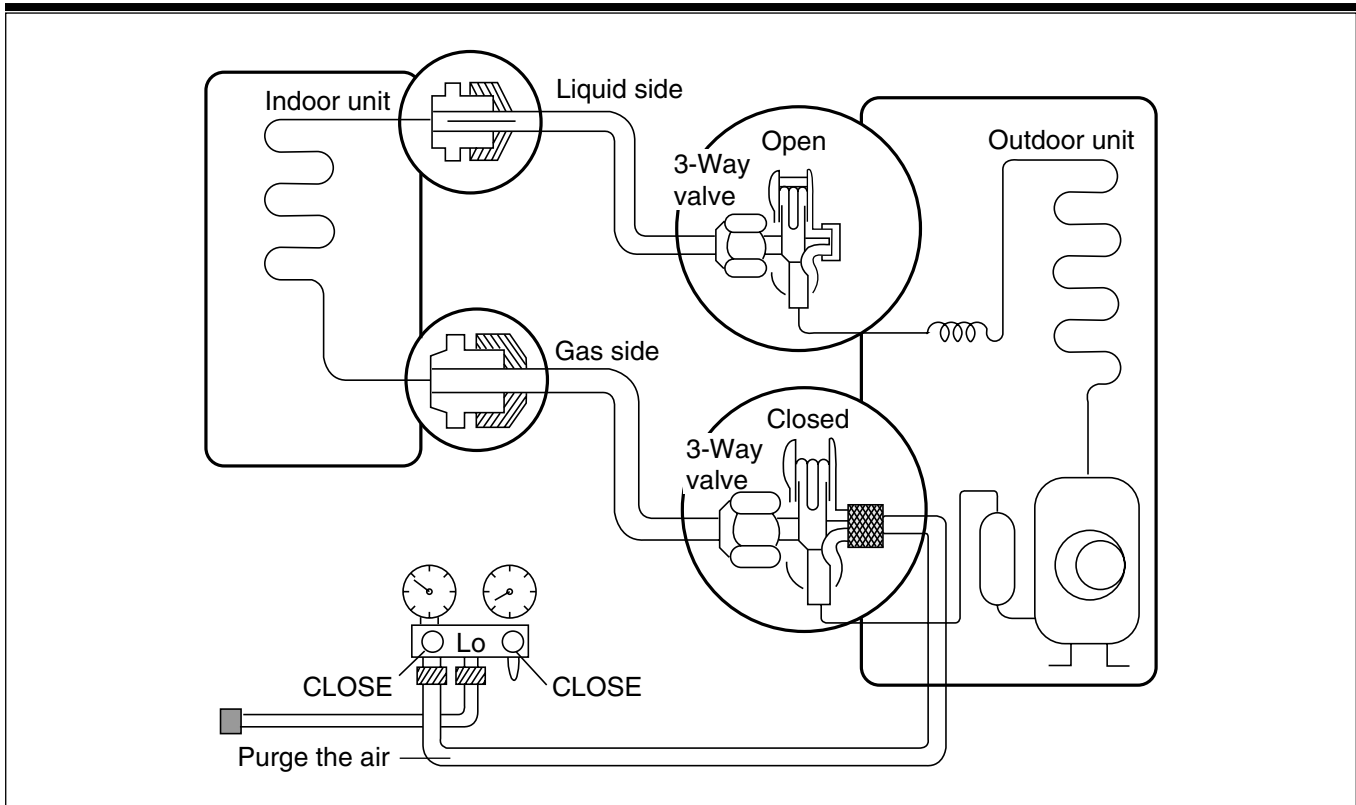

• Procedure

- (1) Confirm that both liquid side and gas side valves are set to the open position.**
 - Remove the valve stem caps and confirm that the valve stems are in the raised position.
 - Be sure to use a hexagonal wrench to operate the valve stems.
- (2) Operate the unit for 10 to 15 minutes.**
- (3) Stop operation and wait for 3 minutes, then connect the charge set to the service port of the 3-way valve.**
 - Connect the charge hose to the service port.
- (4) Air purging of the charge hose.**
 - Open the low-pressure valve on the charge set slightly to air purge from the charge hose.
- (5) Set the liquid side valve to the closed position.**
- (6) Operate the air conditioner in cooling mode and stop it when the gauge indicates 1kg/cm²g.**
- (7) Immediately set the 3-way valve to the closed position.**
 - Do this quickly so that the gauge ends up indicating 3 to 5kg/cm²g.
- (8) Disconnect the charge set, and mount the 2-way and 3-way valve's stem nuts and the service port nut.**
 - Use torque wrench to tighten the service port nut to a torque of 1.8 kg.m.
 - Be sure to check for gas leakage.

1) Re-air purging (Re-installation)

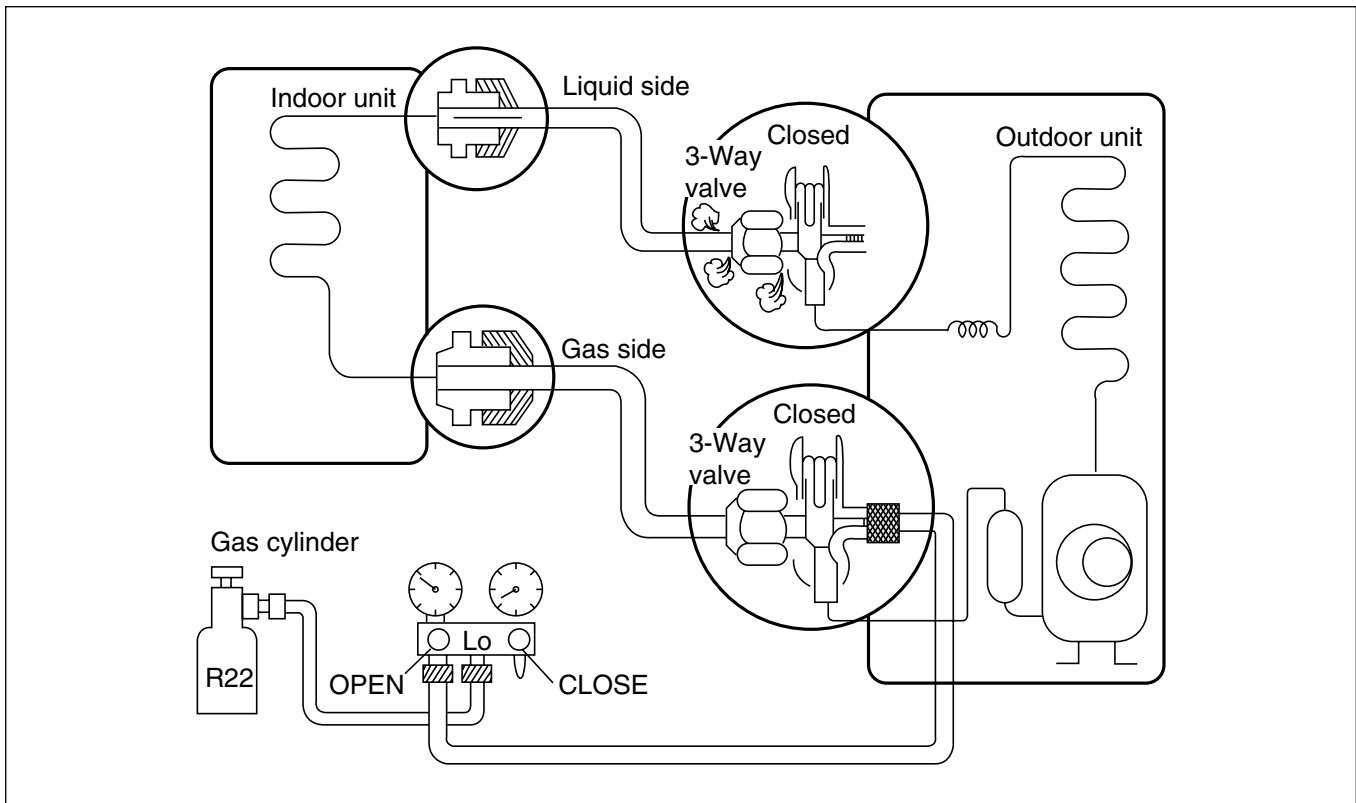

• Procedure

- (1) **Confirm that both the liquid side valve and the gas side valve are set to the closed position.**
 - (2) **Connect the charge set and a gas cylinder to the service port of the 3-way valve.**
 - Leave the valve on the gas cylinder closed.
 - (3) **Air purging.**
 - Open the valves on the gas cylinder and the charge set. Purge the air by loosening the flare nut on the liquid side valve approximately 45° for 3 seconds then closing it for 1 minute; repeat 3 times.
 - After purging the air, use a torque wrench to tighten the flare nut on liquid side valve.
 - (4) **Check for gas leakage.**
 - Check the flare connections for gas leakage.
 - (5) **Discharge the refrigerant.**
 - Close the valve on the gas cylinder and discharge the refrigerant until the gauge indicates 3 to 5 kg/cm²g.
 - (6) **Disconnect the charge set and the gas cylinder, and set the 2-way and 3-way valves to the open position.**
 - Be sure to use a hexagonal wrench to operate the valve stems.
 - (7) **Mount the valve stem nuts and the service port nut.**
 - Use torque wrench to tighten the service port nut to a torque of 1.8 kg.m.
 - Be sure to check for gas leakage.
- * **CAUTION:**
Do not leak the gas in the air during Air Purging.

2) Balance refrigerant of the 3-way valve

(Gas leakage)

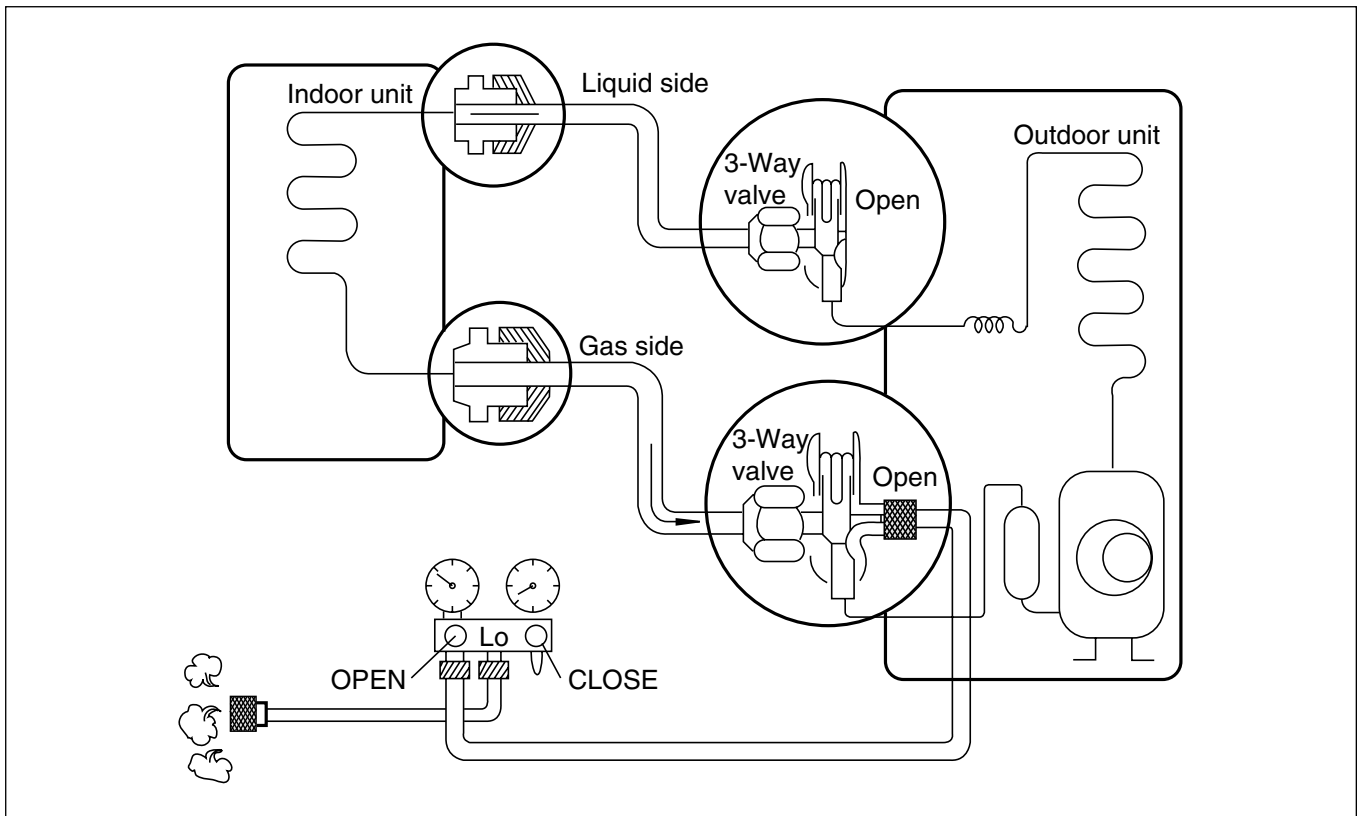

• Procedure

- (1) Confirm that both the liquid side and gas side valves are set to the back seat.
- (2) Connect the charge set to the 3-way valve's port.
 - Leave the valve on the charge set closed.
 - Connect the charge hose to the service port.
- (3) Open the valve (Lo side) on the charge set and discharge the refrigerant until the gauge indicates 0 kg/cm²G.
 - If there is no air in the refrigerant cycle (the pressure when the air conditioner is not running is higher than 1 kg/cm²G), discharge the refrigerant until the gauge indicates 0.5 to 1 kg/cm²G. if this is the case, it will not be necessary to apply a evacuation.
 - Discharge the refrigerant gradually; if it is discharged too suddenly, the refrigeration oil will also be discharged.

2. Evacuation

(All amount of refrigerant leaked)

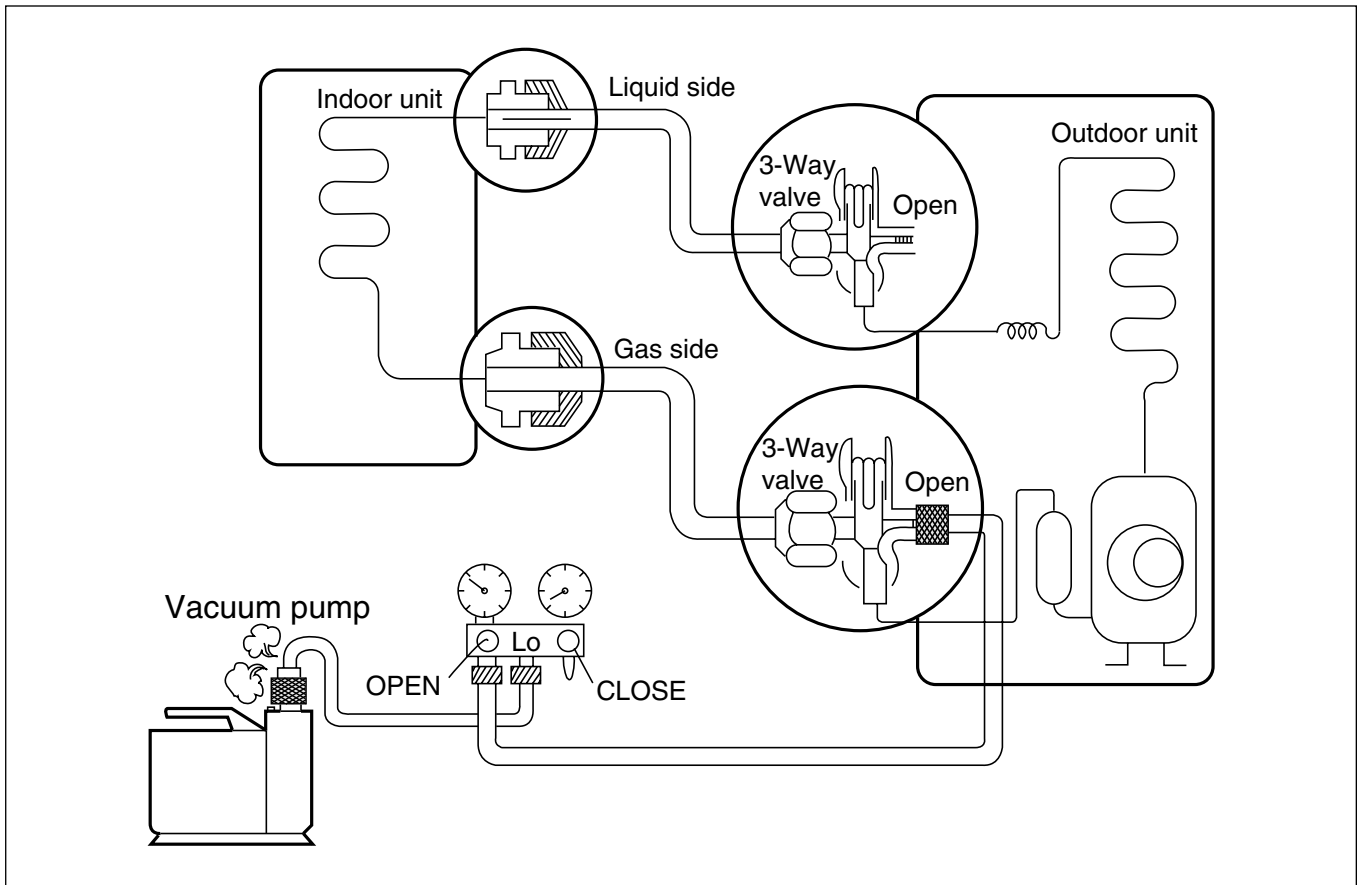

• Procedure

- (1) Connect the vacuum pump to the center hose of charge set center hose
- (2) Evacuation for approximately one hour.
 - Confirm that the gauge needle has moved toward -76 cmHg (vacuum of 4 mmHg or less).
- (3) Close the valve (Lo side) on the charge set, turn off the vacuum pump, and confirm that the gauge needle does not move (approximately 5 minutes after turning off the vacuum pump).
- (4) Disconnect the charge hose from the vacuum pump.
 - Vacuum pump oil.
If the vacuum pump oil becomes dirty or depleted, replenish as needed.

3. Gas Charging

(After Evacuation)

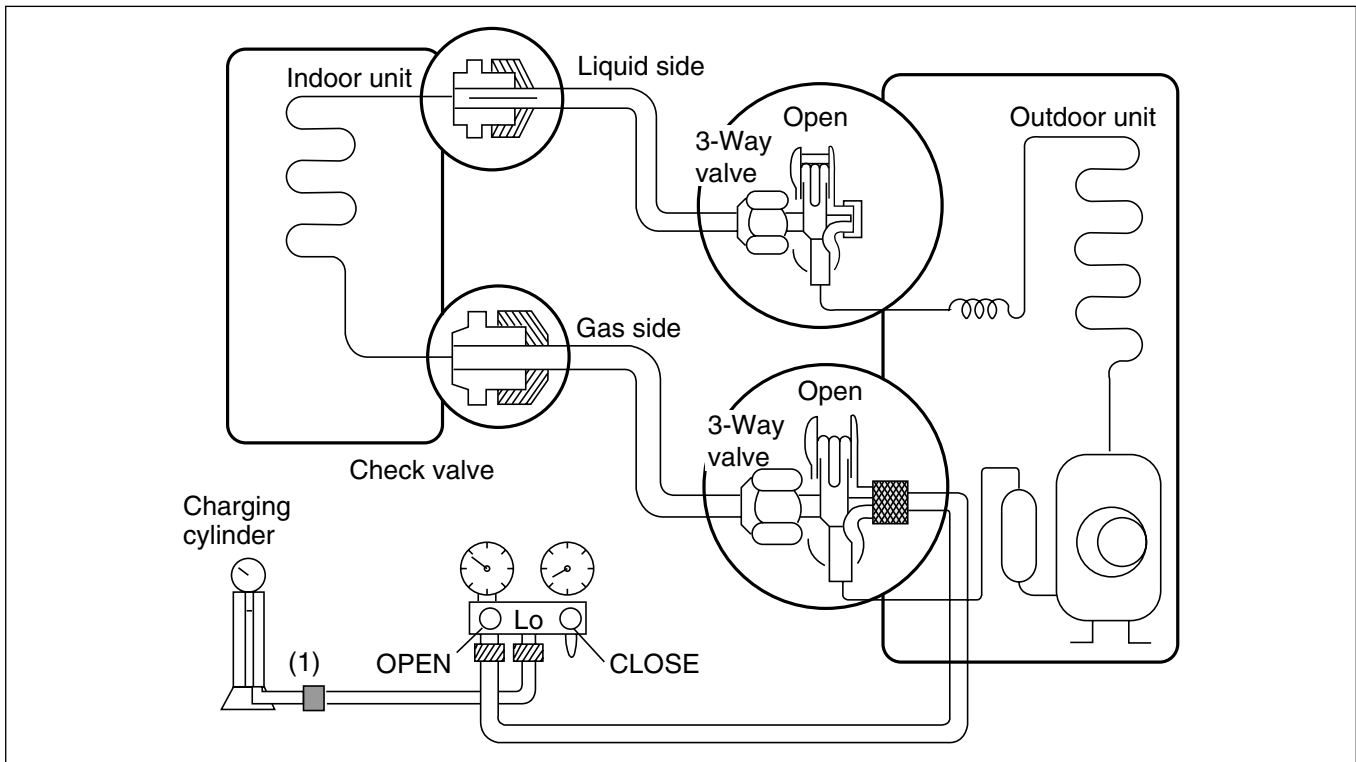

• Procedure

(1) Connect the charge hose to the charging cylinder.

- Connect the charge hose which you disconnected from the vacuum pump to the valve at the bottom of the cylinder.
- If you are using a gas cylinder, also use a scale and reverse the cylinder so that the system can be charged with liquid.

(2) Purge the air from the charge hose.

- Open the valve at the bottom of the cylinder and press the check valve on the charge set to purge the air. (Be careful of the liquid refrigerant). The procedure is the same if using a gas cylinder.

(3) Open the valve (Lo side on the charge set and charge the system with liquid refrigerant.

- If the system can not be charged with the specified amount of refrigerant, it can be charged with a little at a time (approximately 150g each time) while operating the air conditioner in the cooling cycle; however, one time is not sufficient, wait approximately 1 minute and then repeat the procedure (pumping down-pin).

This is different from previous procedures.

Because you are charging with liquid refrigerant from the gas side, absolutely do not attempt to charge with larger amounts of liquid refrigerant while operating the air conditioner.

(4) Immediately disconnect the charge hose from the 3-way valve's service port.

- Stopping partway will allow the gas to be discharged.
- If the system has been charged with liquid refrigerant while operating the air conditioner turn off the air conditioner before disconnecting the hose.

(5) Mount the valve stem nuts and the service port nut.

- Use torque wrench to tighten the service port nut to a torque of 1.8 kg.m.
- Be sure to check for gas leakage.

Cycle Troubleshooting Guide

Trouble analysis

1. Check temperature difference between intake and discharge air and operating current.

	Temp. difference : approx. 0°C Current : less than 80% of rated current	All amount of refrigerant leaked out Check refrigeration cycle
Temp. Difference	Temp. difference : approx. 8°C Current : less than 80% of rated current	Refrigerant leakage Clog of refrigeration cycle Defective compressor
Operating Current	Temp. difference : less than 8°C Current : over the rated current	Excessive amount of refrigerant
	Temp. difference : over 8°C	Normal

Notice :

Temperature difference between intake and discharge air depends on room air humidity. When the room air humidity is relatively higher, temperature difference is smaller. When the room air humidity is relatively lower temperature difference is larger.

2. Check temperature and pressure of refrigeration cycle.

Suction pressure (Compared with the normal value)	Temperature (Compared with the normal value)	Cause of Trouble	Description
Higher	High	Defective compressor Defective 4-way reverse valve	Current is low
	Normal	Excessive amount of refrigerant	High pressure does not quickly rise at the beginning of operation
Lower	Higher	Insufficient amount of refrigerant (Leakage)	Current is low
		Clogging	Current is low

Notice :

1. The suction pressure is usually 4.5~6.0 kg/cm²G at normal condition.
2. The temperature can be measured by attaching the thermometer to the low pressure tubing and wrap it with putty.

Electronic Parts Troubleshooting Guide

Possible Trouble 1 : The unit does not operate.

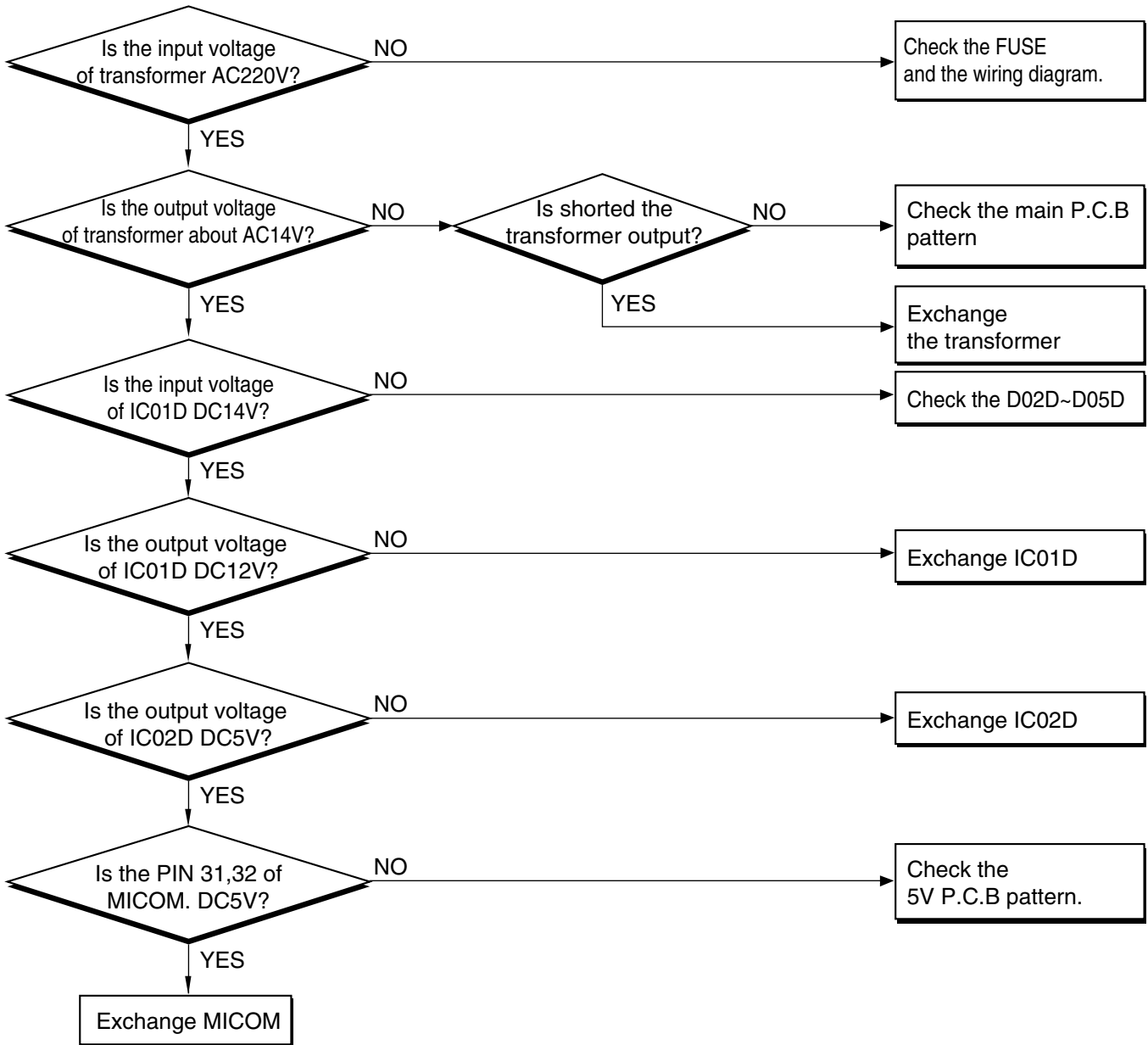

Possible Trouble 2 : The indoor fan does not operate.

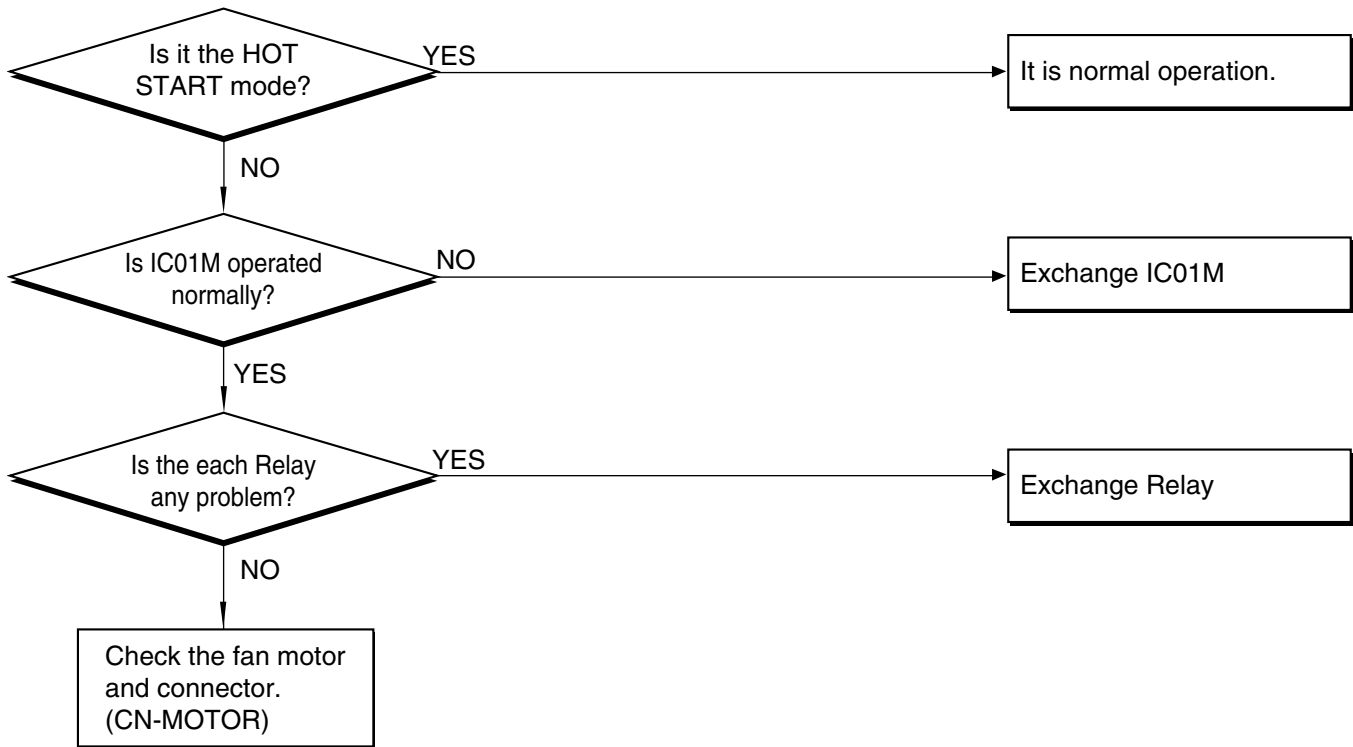

Possible Trouble 3 : Wired remote controller does not operate.

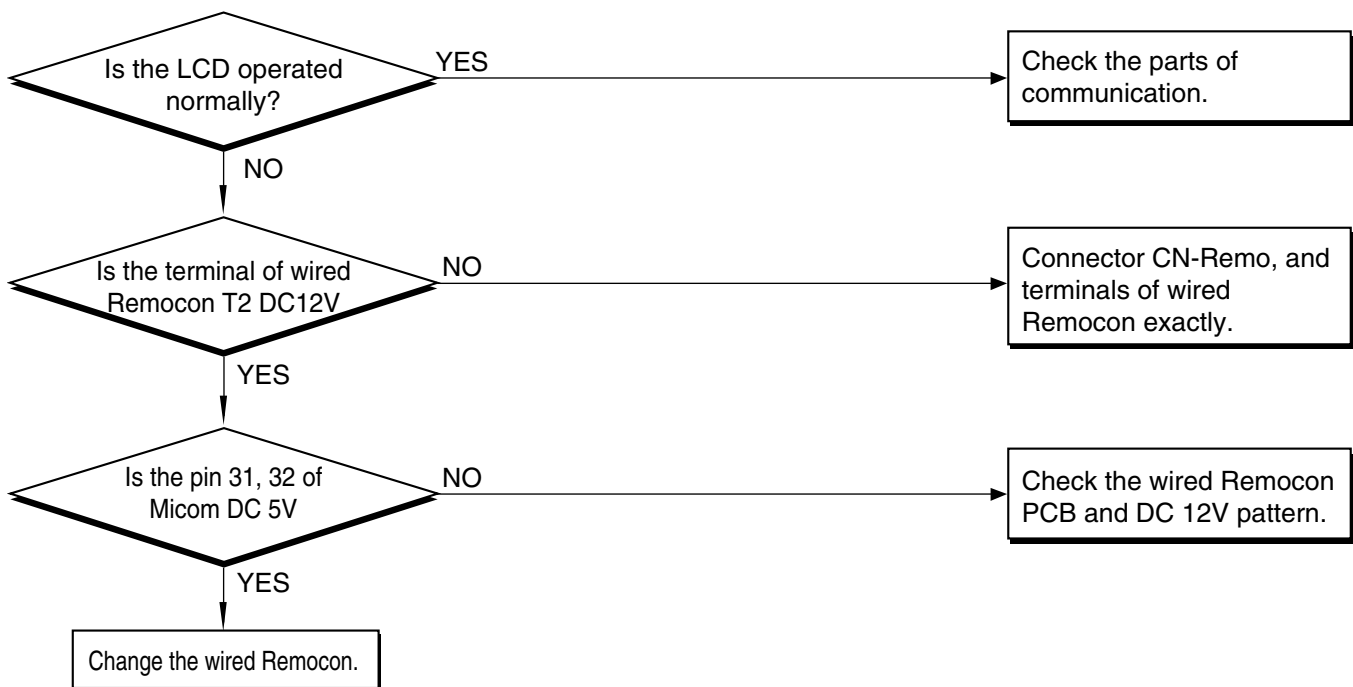

Possible Trouble 4 : Ineffective Heating

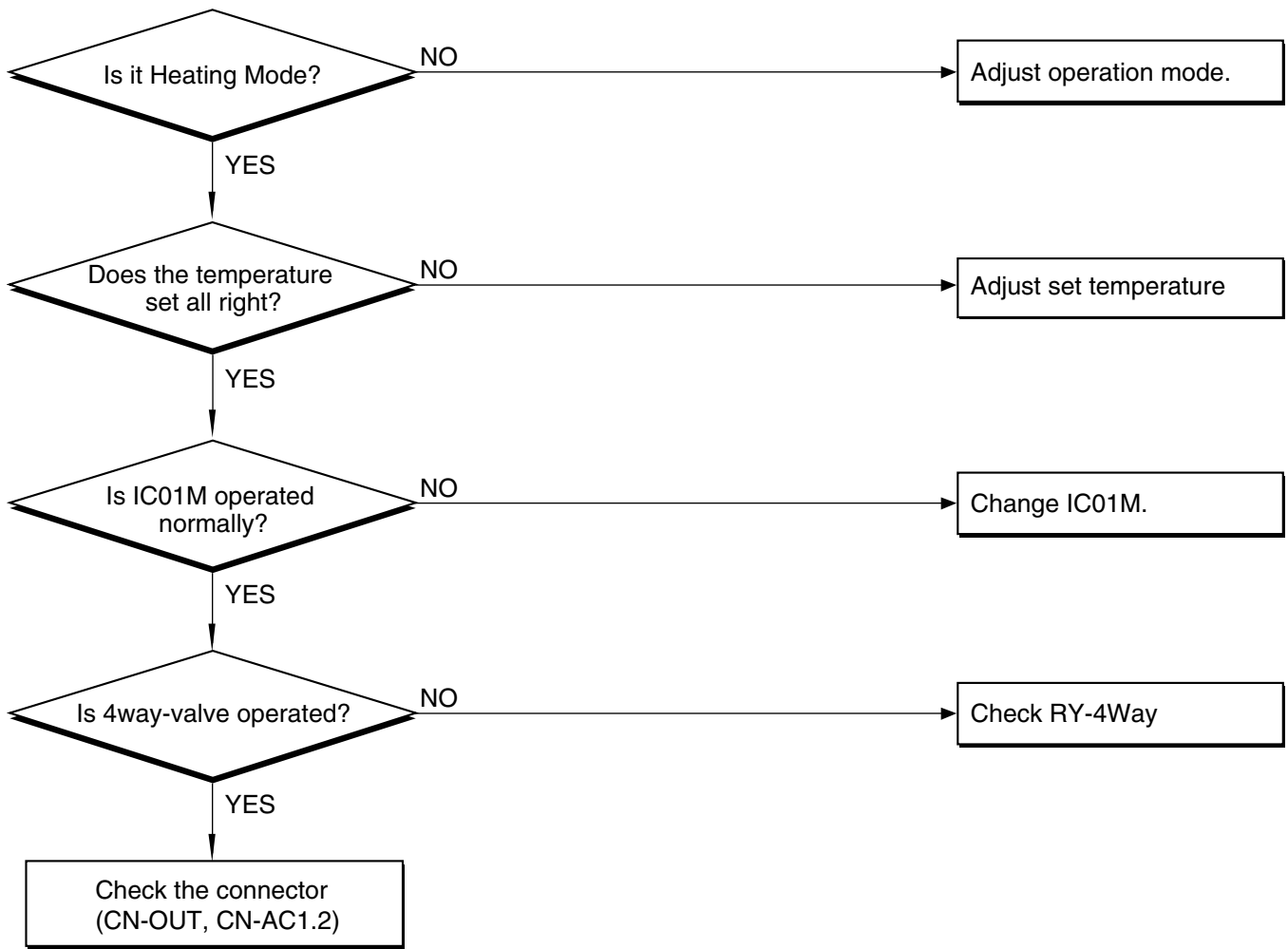

Electronic control device

• MAIN P.C.B ASM

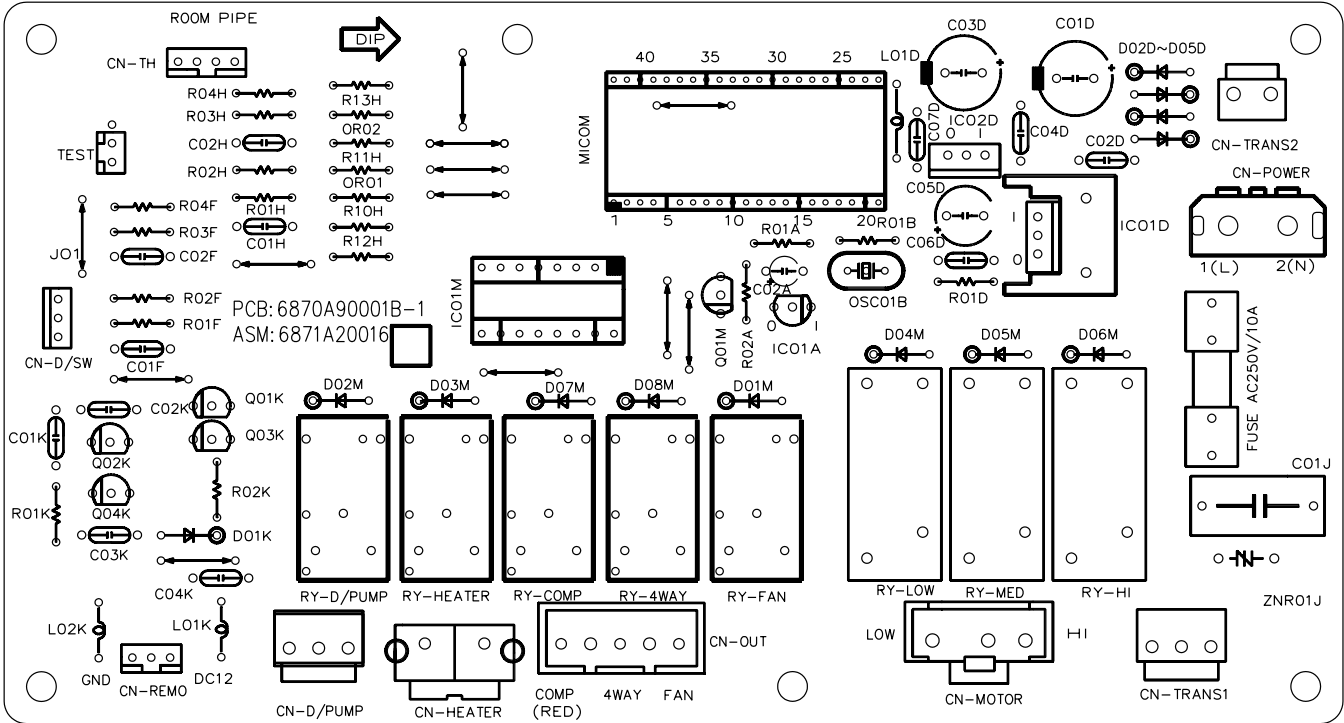

Schematic Diagram

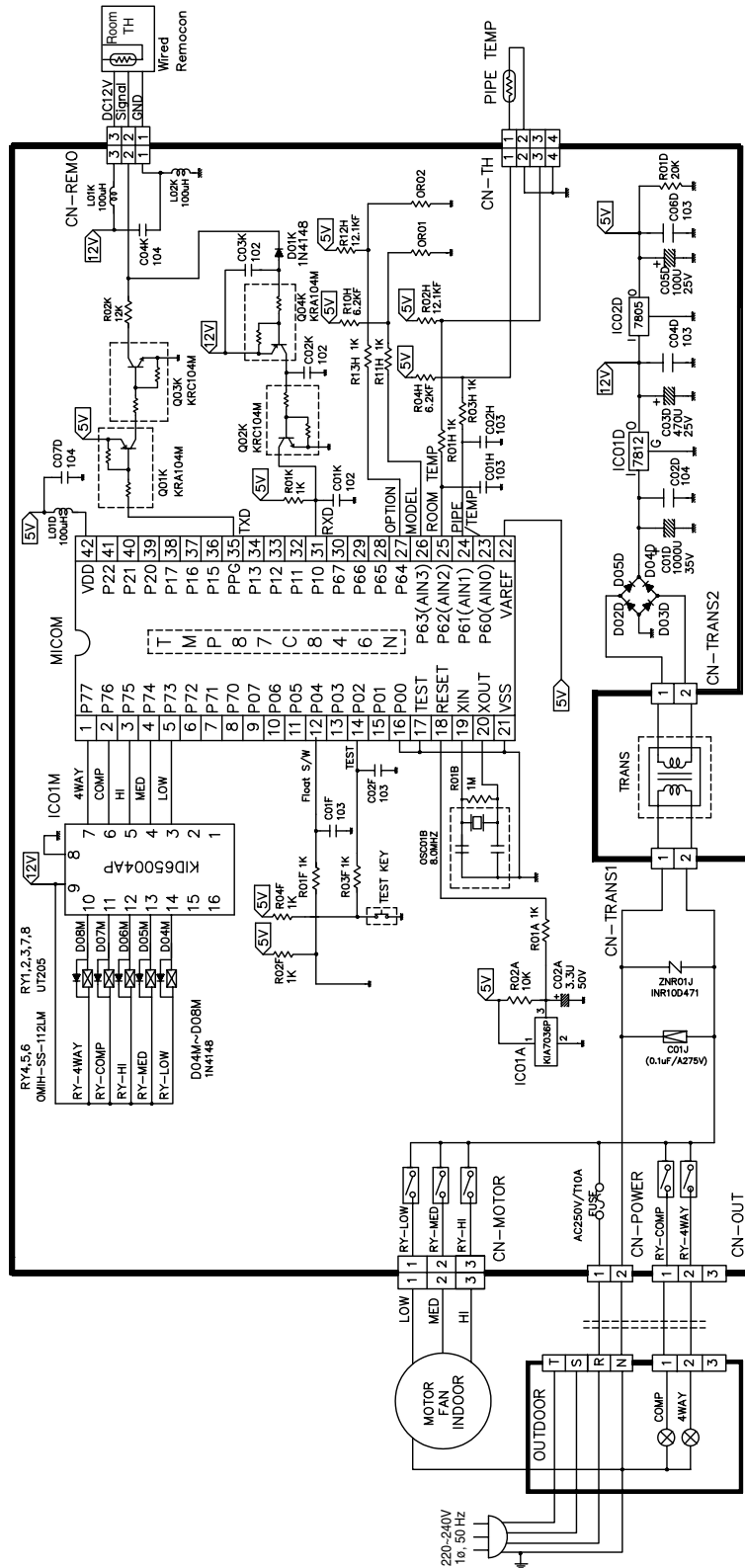

Exploded View and Replacement Parts List

1. Indoor Unit

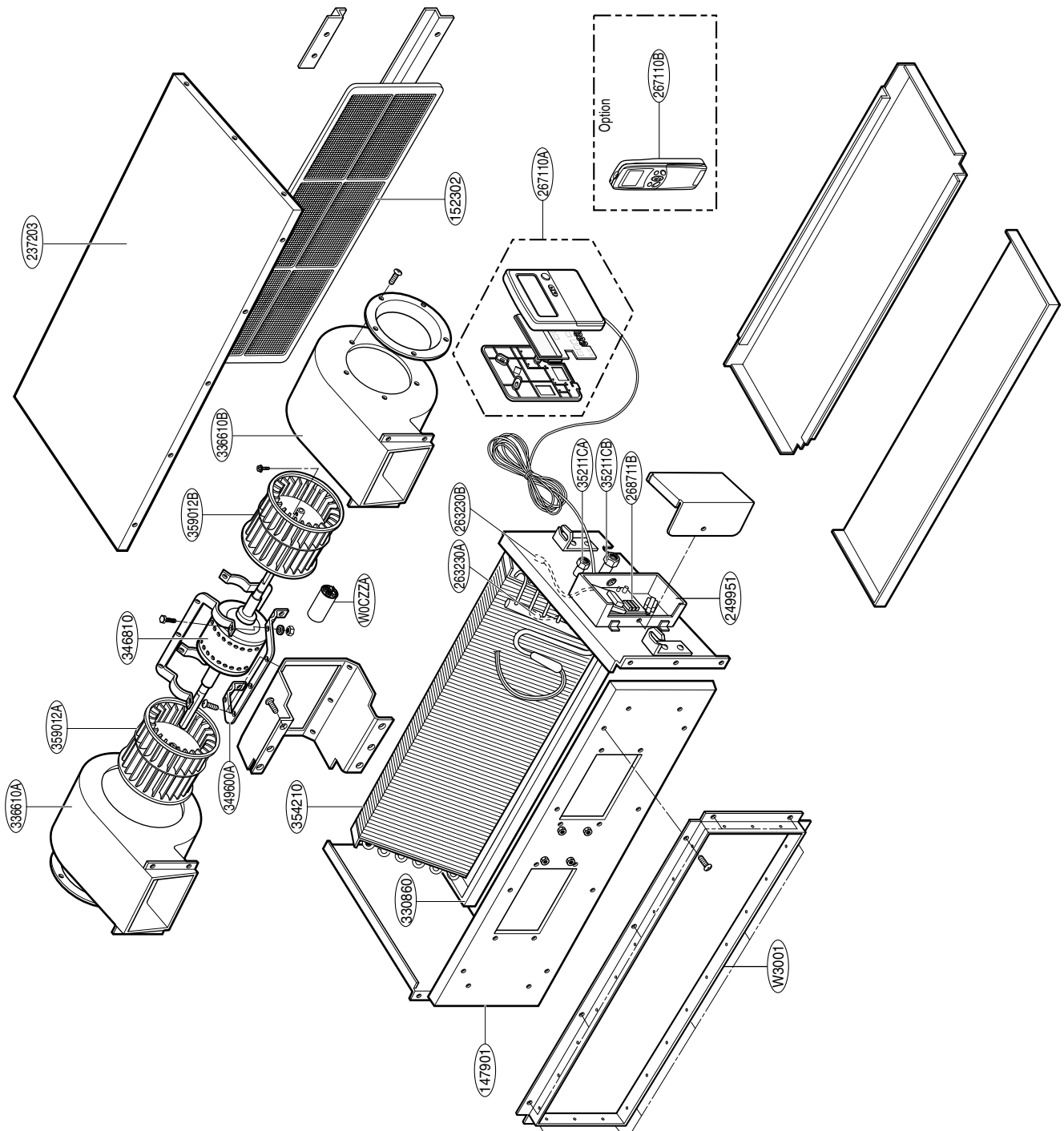

2. Outdoor Unit

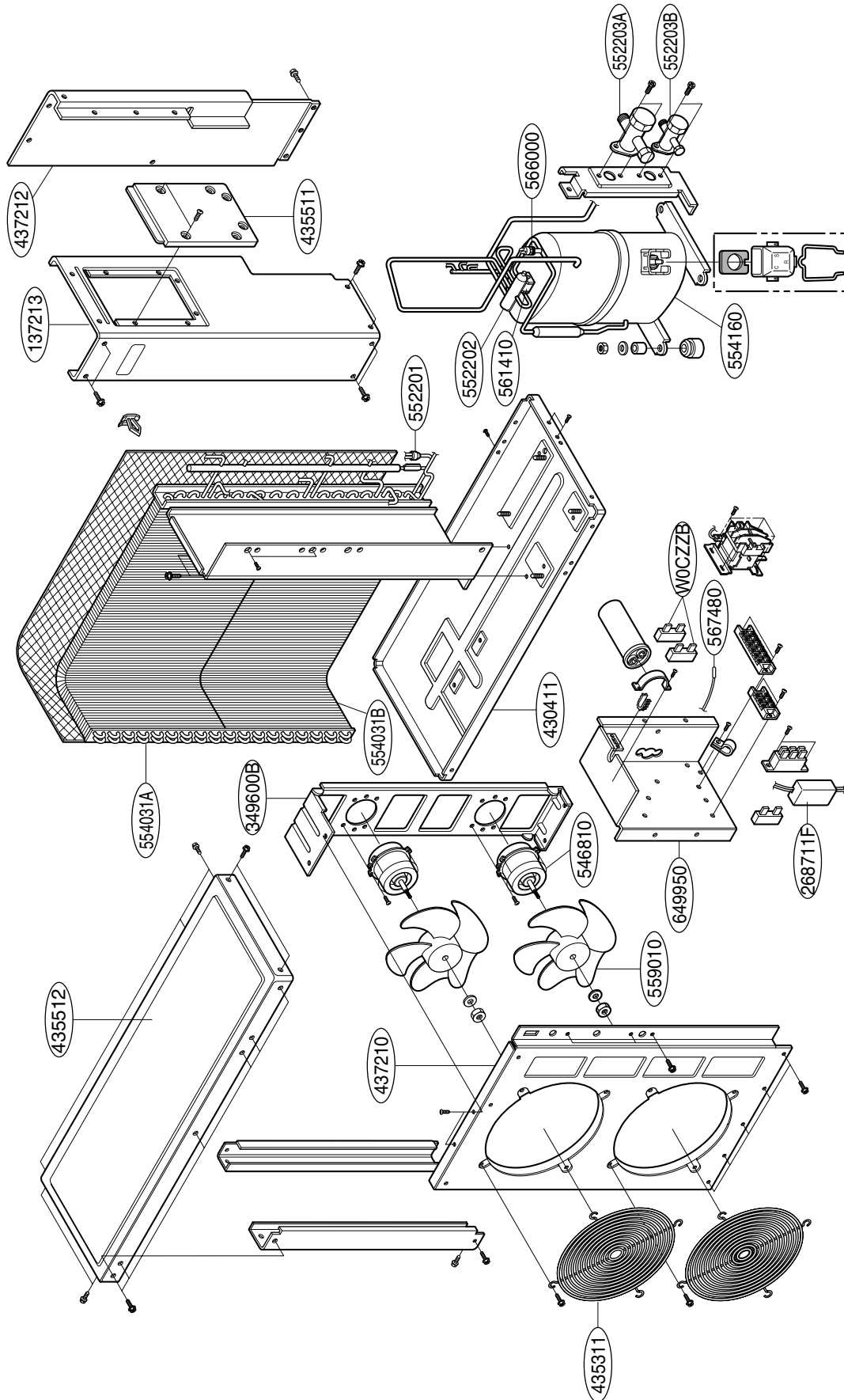



P/NO : 3828A30074M

APRIL, 2008